



An Oshkosh Corporation Company

Deutz D/TD/TCD 2011

SUPPLEMENTAL OPS MANUAL

Models:

***400S, 400SC, 450AJ, 600A, 600S, 600SC,
800A, 800S, 1200/1350SJP, 1250AJP,
1500SJ***

Component Manufacturer PN: 03123547

3124206

11/05/2018 - Rev-A

DISCLAIMER: Information provided within is supplied directly from the component manufacturer. The information has not been altered in any way and is the sole property of the component manufacturer. Due to continuous improvements, the component manufacturer reserves the right to make changes without prior notification. Contact the component manufacturer for the latest information.

REVISION LOG

Original Issue A - November 5, 2018

Revised B -

Operation Manual
D/TD/TCD 2011

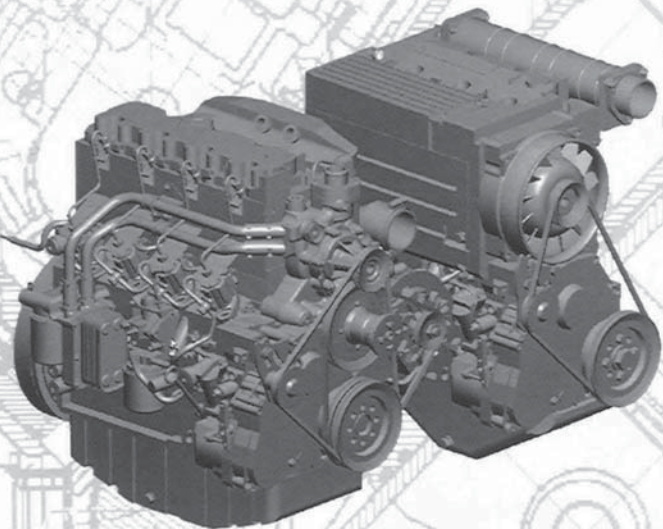

3124206

Notes

Notes

- This engine is defined exclusively for purpose according to the scope of delivery and built by the equipment manufacturer (use for the intended purpose). Any other use above and beyond this will be considered as misuse. The manufacturer will not accept any liability for damages resulting from this. The user bears the sole risk.
- Use for the intended purpose also includes observance of the operating, maintenance and repair conditions specified by the manufacturer. The engine should only be operated, serviced and repaired by personnel trained in its use and the hazards involved.
The pertinent rules for the prevention of accidents and other generally recognised safety and industrial medicine rules must be observed.
- When the engine is running there is a danger of injury caused by:
 - rotating and hot components
 - on motors with external ignition (high electrical voltage). Contact must be avoided!
- Unauthorised engine modifications will invalidate any liability claims against the manufacturer for resultant damage.
- Equally, manipulations to the injection and control system can affect the engine's performance and the exhaust characteristics. Adherence to legislation on pollution can no longer be guaranteed under such conditions.
- Do not change the cooling air feed area to the blower or fan. An unobstructed cooling air supply must be guaranteed.
The manufacturer will accept no liability for damage resulting from this.
- When carrying out maintenance work on the en-

gine, the use of DEUTZ original parts is prescribed. These are specially designed for your engine and guarantee perfect operation.

Non-compliance results in the expiry of the warranty!

Maintenance/cleaning work on the engine may only be carried out when the engine is not running and has cooled down.

When doing this, make sure that the electrical system is switched off (remove ignition key).

The specifications for accident prevention with electrical systems (e.g. VDE-0100/0101/-0104/-0105 Electrical protective measures against dangerous contact voltages) must be observed.

Cover all electrical components tightly when cleaning with liquids.

- Do not work on the fuel system while the engine is running - **Danger to life!**
Wait for the pressure to drop after the engine has come to a standstill (in engines with DEUTZ Common Rail about 5 minutes, otherwise 1 minute) because the system is under high pressure - **Danger to life!**
During the first trial run do not stand in the danger area of the engine.
Danger due to high pressure in case of leaks - **Danger to life!**
 - In case of leaks immediately contact workshop.
 - When working on the fuel system, make sure that the engine is not started inadvertently during repairs - **Danger to life!**

Dear customer,

Congratulations on the purchase of your DEUTZ engine.

DEUTZ air/liquid-cooled engines are developed for a broad spectrum of applications. Consequently, a wide range of variants is offered to meet the requirements of specific cases.

The engine is equipped accordingly for the particular installation situation, i.e. not all the components described in the operating manual are installed in your engine.

We have endeavoured to highlight any differences so that you will be able to locate the operating and maintenance instructions applicable to your engine more quickly and easily.

Please make sure that this operating manual is available to everyone involved in the operation, maintenance and repair of the engine and that they have understood the contents.

If you have any queries, please contact us, we'll be happy to advise you.

Sincerely,
DEUTZ AG

Engine serial number

Please enter the engine serial number here. This will simplify the handling of customer service, repair and spare parts queries.

--	--	--	--	--	--	--	--

Notes

We reserve the right to make technical changes to the descriptions and data in this operating manual in the interest of further development of the engines.

This document may only be reprinted and reproduced, even in part, with our express permission.

Contents

Notes	2	Suction system	47
Foreword	3	Belt drives	49
1 General	5	Setting work	51
2 Engine description	7	Electrical system	53
Type	7	7 Faults	55
Engine illustrations	9	Fault table	55
Lubricating oil schematic	13	Engine management	60
Fuel schematic	18	8 Transport and storage	62
Coolant schematic	19	Transport	62
Exhaust gas recirculation	21	Protecting the engine against corrosion	63
Electrics/Electronics	23	9 Technical data	65
3 Operation	24	Engine and setting data	65
Ambient conditions	24	Tools	70
Initial commissioning	25		
Start procedure	27		
Operation monitoring	28		
Stop procedure	30		
4 Operating media	31		
Lubricating oil	31		
Fuel	33		
Coolant	34		
5 Maintenance	35		
Maintenance schedule	35		
6 Care and maintenance work	38		
Lubricating oil system	38		
Fuel system	40		
Cooling system	44		
Engine cleaning	46		

DEUTZ diesel engines

DEUTZ diesel engines are the product of years of research and development. Profound know-how combined with high quality requirements are the guarantee for the production of engines with a long life, high reliability levels and low fuel consumption. Obviously the high requirements for the protection of the environment are also met.

Safety precautions when the engine is running

Maintenance work or repairs may only be performed on the shut-down engine. Make sure that the engine cannot be started inadvertently - **Danger of accident!**

After repair work: Check that all guards have been replaced and that all tools have been removed from the engine.

Observe industrial safety regulations when running the engine in an enclosed space or underground.

When working on the running engine, work clothing must be close fitting.

Never fill the fuel tank while the engine is running.

Service and Maintenance

Service and maintenance are also decisive for whether the engine satisfactorily meets the set demands. Recommended service intervals must therefore be observed and service and maintenance work must be carried out conscientiously.

Special care should be taken under abnormally demanding operating conditions.

Original DEUTZ parts

Original DEUTZ parts are subject to the same strict quality demands as the DEUTZ engines. Further de-

velopments for improving the engines are also introduced in the original DEUTZ parts of course. Only the use of original DEUTZ parts manufactured according to the state-of-the-art can guarantee perfect functioning and high reliability.

DEUTZ Xchange components

DEUTZ replacement parts are a low-cost alternative. Of course, the quality standards here are just as high as for new parts. DEUTZ replacement parts are equal to the original DEUTZ parts in function and reliability.

Asbestos

The gaskets used in this engine contain no asbestos. Please use the appropriate original DEUTZ parts for maintenance and repair work.

Service

We want to preserve the high performance of our engines, and with it the confidence and satisfaction of our customers. We are therefore represented worldwide by a network of service branches.

The DEUTZ name does not merely stand for engines that are the products of extensive development work, DEUTZ also stands for complete service packages that ensure optimum operation of our engines, and for customer services operations that you can count on.

Please contact your DEUTZ-partner in case of malfunctions and spare parts inquiries. Our specially trained personnel will ensure fast, professional repairs using original DEUTZ spare parts in case of damage.

The DEUTZ home page gives you a continuously up-to-date overview of the service partners in your vicin-

ity with notes on product responsibilities and services. Or you can use another fast, convenient way via the Internet under www.deutzshop.de. The DEUTZ P@rts Online parts catalogue gives you a direct contact to your nearest local service partner.

California Proposition 65 Warning

Diesel engines and some of its constituents are known to the State of California to cause cancer, birth defects and other reproductive harm.

Masthead

DEUTZ AG

Ottostraße 1

51149 Köln

Germany

Phone: +49 (0) 221-822-0

Fax: +49 (0) 221-822-5850

www.deutz.com

E-Mail: info@deutz.com

General

1

Danger



This symbol is used for all safety instructions which, if not observed, present a direct danger to life and limb for the person involved. Observe these carefully. The attention of operating personnel should be drawn to these safety instructions. Furthermore, the legislation for "general regulations for safety and the prevention of accidents" must be observed.

Caution



This symbol indicates a danger to the part and engine. The relevant instructions must be observed, failure to do so can lead to destruction of the part and the engine.

Notes



This symbol accompanies notes of a general kind.

Type

Engine type designation

This manual covers the following engine types		
D 2011 L02 i	D 2011 L02 o	D 2011 L04 w
D 2011 L03 i	D 2011 L03 o	TD 2011 L04 w
D 2011 L04 i	D 2011 L04 o	TCD 2011 L04 w
TD 2011 L04 i	TD 2011 L04 o	

TCD	
T	Exhaust gas turbocharger
C	Charge air cooler
D	Diesel

2011	
2011	Series

L02/L03/L04	
L	in series
02	No. of cylinders
03	No. of cylinders
04	No. of cylinders

i/o/w	
i	oil-cooled (integrated cooler)
o	oil-cooled
w	water-cooled

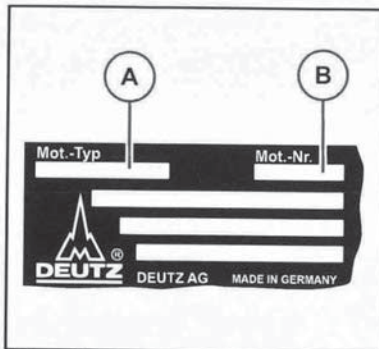

Rating plate

The type (A), engine number (B) and performance data are stamped on the rating plate.

The engine type and number must be stated when purchasing spare parts.

Engine description

2

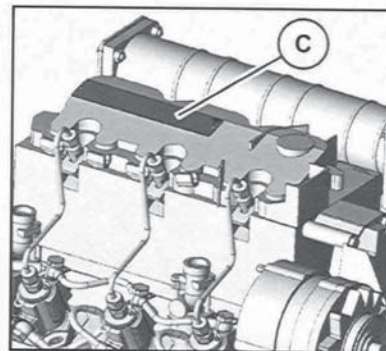

Location of the rating plate

The rating plate (C) is fixed to the cylinder head cover or the crankcase.

2

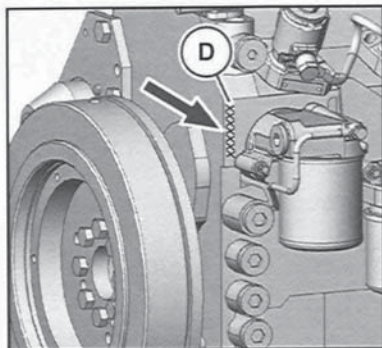

Engine serial number

The engine number (D) is stamped onto the crankcase (arrow) and onto the rating plate.

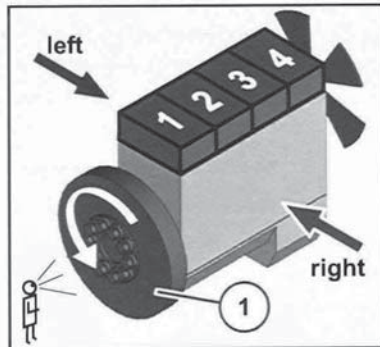

Cylinder numbering

Cylinder arrangement

The cylinders are counted consecutively starting from flywheel (1).

Direction of rotation

Looking onto the flywheel.

rotating to the left: counter-clockwise.

Engine sides

Looking onto the flywheel.

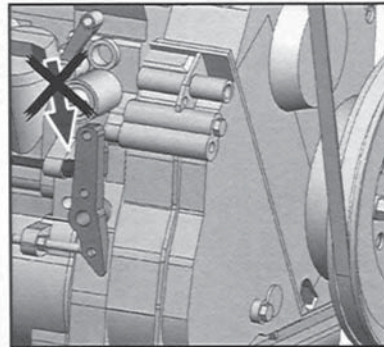

Volume blocking

Unauthorised settings on the regulator will exclude the manufacturer from all liability for resulting damage. The blocking screws are adequately protected against this:

- With locking varnish in version: torque adjustment
- With protective plastic capsule in version: without torque adjustment.

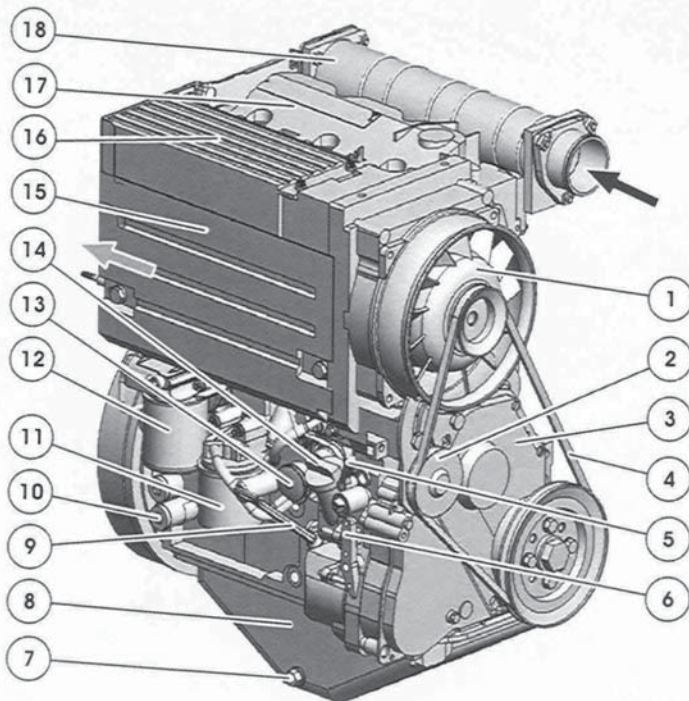

D 2011 L03 i

View from right (example)

- 1 Cooling fan (with integrated generator)
- 2 Tension pulley
- 3 Toothed belt cover
- 4 V-belt (fan)
- 5 Stop lever
- 6 Speed adjusting lever
- 7 Lubricating oil drain plug
- 8 Lubricating oil sump
- 9 Lubricating oil dipstick
- 10 Connection possibility for cab heating
- 11 Exchangeable fuel filter
- 12 Lube oil replacement filter
- 13 Fuel supply pump with integrated screen filter
- 14 Lubricating oil filling
- 15 Removable air guidance cowling (access to fuel injectors)
- 16 Lube oil cooler
- 17 Cylinder head cover
- 18 Air intake pipe

2

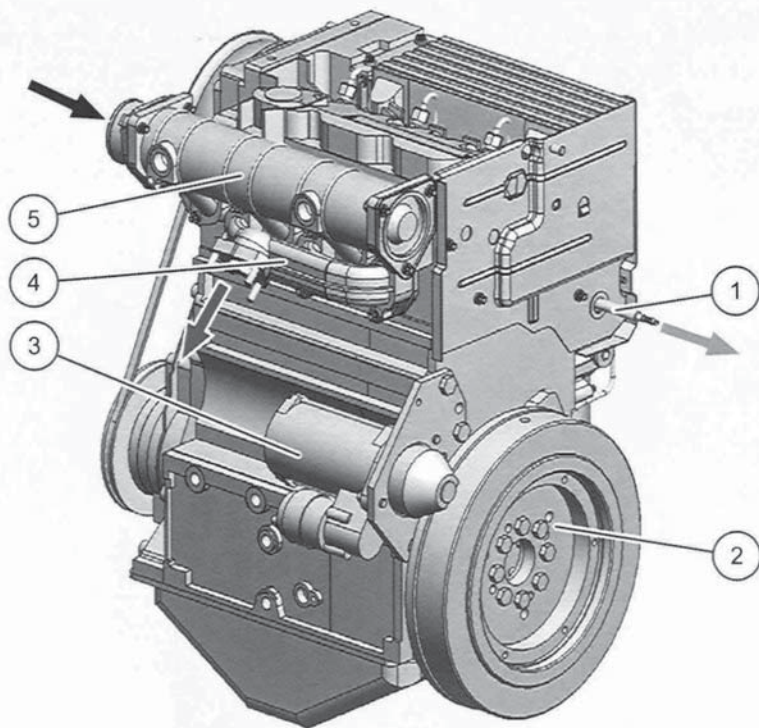

D 2011 L03 i

View from left (example)

- 1 Fuel return to fuel tank
- 2 Flywheel
- 3 Starter
- 4 Exhaust manifold line
- 5 Air intake pipe

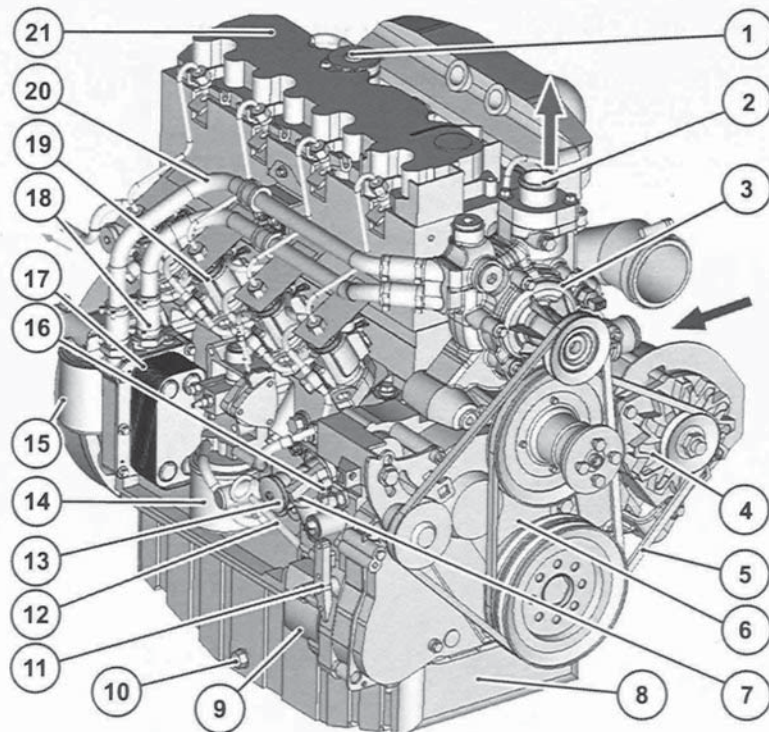

TCD 2011 L04 w

View from right (example)

- 1 Crankcase breather
- 2 Coolant outlet to the cooler
- 3 Coolant pump
- 4 Generator
- 5 V-belts
- 6 Toothed belt cover
- 7 Lubricating oil filling
- 8 Lubricating oil sump
- 9 Lubricating oil pump
- 10 Lubricating oil drain plug
- 11 Speed adjusting lever
- 12 Lubricating oil dipstick
- 13 Fuel supply pump with integrated screen filter
- 14 Exchangeable fuel filter
- 15 Lube oil replacement filter
- 16 Stop lever
- 17 Lube oil cooler
- 18 Coolant inlet
- 19 Injection pump
- 20 Coolant return to thermostat
- 21 Cylinder head cover

2

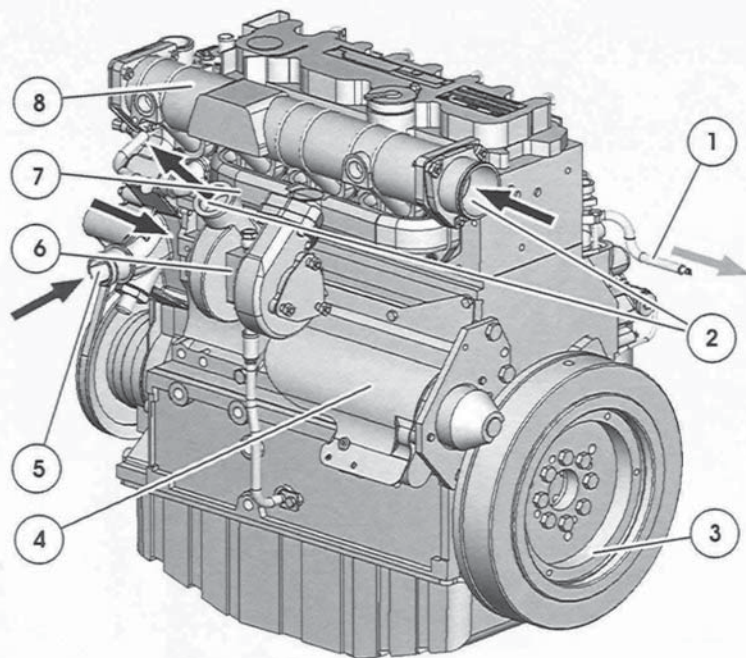

TCD 2011 L04 w

View from left (example)

- 1 Fuel return to fuel tank
- 2 Connections charge air cooler
- 3 Flywheel
- 4 Starter
- 5 Coolant inlet
- 6 Turbocharger
- 7 Exhaust manifold line
- 8 Charge air line

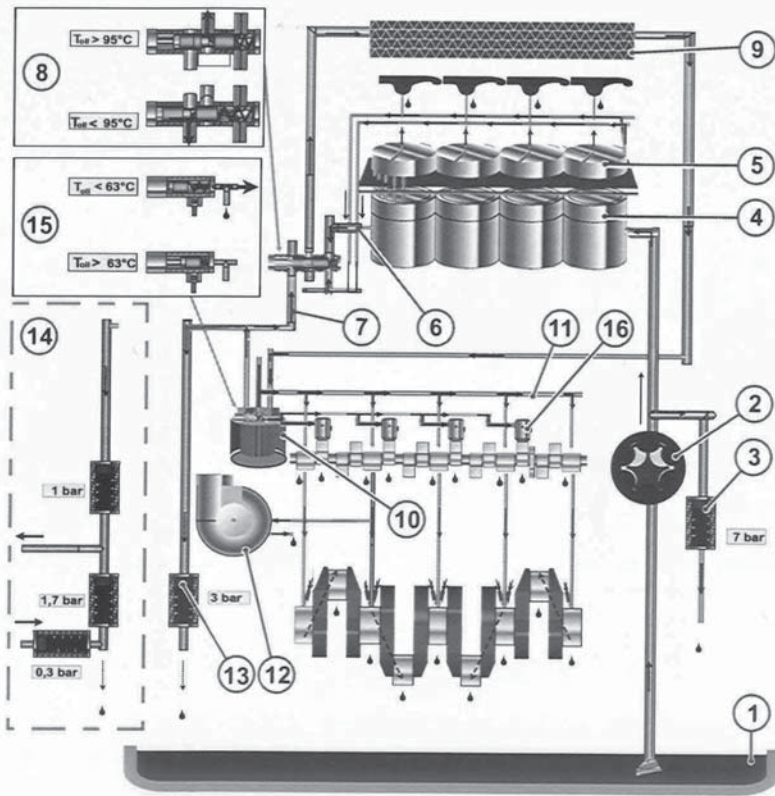

TD 2011 L04 i

(example)

- 1 Lubricating oil sump
- 2 Lubricating oil pump
- 3 Pressure limiting valve
- 4 Cylinder (lubricating oil-cooled)
The lubricating oil is used first to cool the engine.
- 5 Cylinder head
- 6 Lubricating oil return from the cylinders
- 7 Lubricating oil collection pipe to the thermostat
- 8 Thermostat
(engine cold) lubricating oil flow directly to the lubricating oil filter
(engine warm) lubricating oil flow through the lubricating oil cooler
- 9 Lube oil cooler
- 10 Lubricating oil filter
- 11 Main lube oil channel
- 12 Turbocharger
- 13 Pressure holding valve
- 14 Connection possibility for cab heating
The standard pressure holding valve must be replaced by a combination for this. Retrofitting only by authorised qualified personnel.
- 15 Lubricating oil filter console with integrated switching valve for controlling the hydraulic tappet.
When the engine is cold, lubricating oil is fed to the hydraulic tappet.
To achieve early adjustment of the fuel injection in a cold start, the hydraulic tappets under the fuel injectors are supplied with lubricating oil.
- 16 Hydraulic tappets

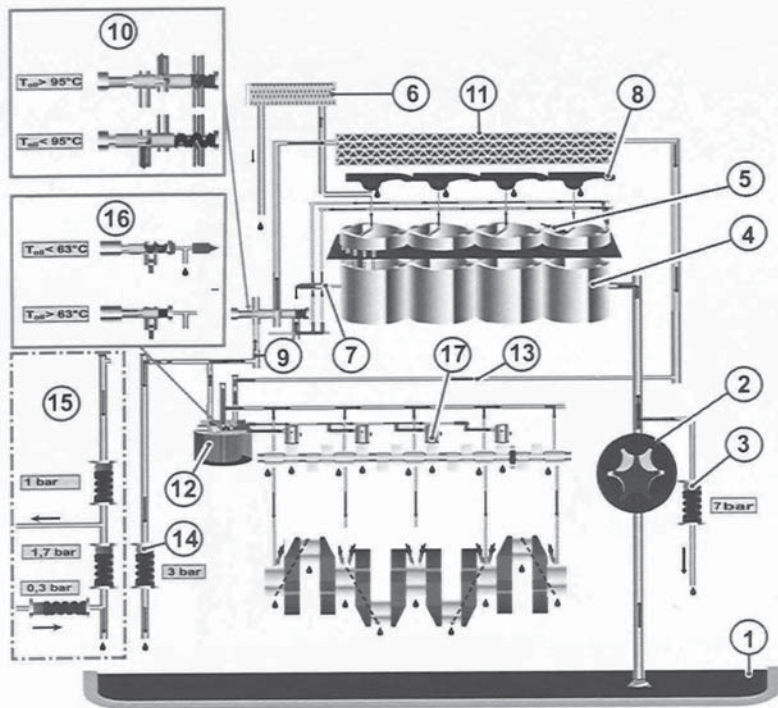

D 2011 L04 i

Exhaust gas recirculation

(example)

- 1 Lubricating oil sump
- 2 Lubricating oil pump
- 3 Pressure limiting valve
- 4 Cylinder (lubricating oil-cooled)
The lubricating oil is used first to cool the engine.
- 5 Cylinder head
- 6 Cooling valve housing (exhaust gas recirculation)
- 7 Lubricating oil return from the cylinders
- 8 Rocker arm
- 9 Lubricating oil collection pipe to the thermostat
- 10 Thermostat
(engine cold) lubricating oil flow directly to the lubricating oil filter
(engine warm) lubricating oil flow through the lubricating oil cooler
- 11 Lube oil cooler
- 12 Lubricating oil filter
- 13 Main lube oil channel
- 14 Pressure holding valve
- 15 Connection possibility for cab heating
The standard pressure holding valve must be replaced by a combination for this. Retrofitting only by authorised qualified personnel.
- 16 Lubricating oil filter console with integrated switching valve for controlling the hydraulic tappet.
When the engine is cold, lubricating oil is fed to the hydraulic tappet.
To achieve early adjustment of the fuel injection in a cold start, the hydraulic tappets under the fuel injectors are supplied with lubricating oil.

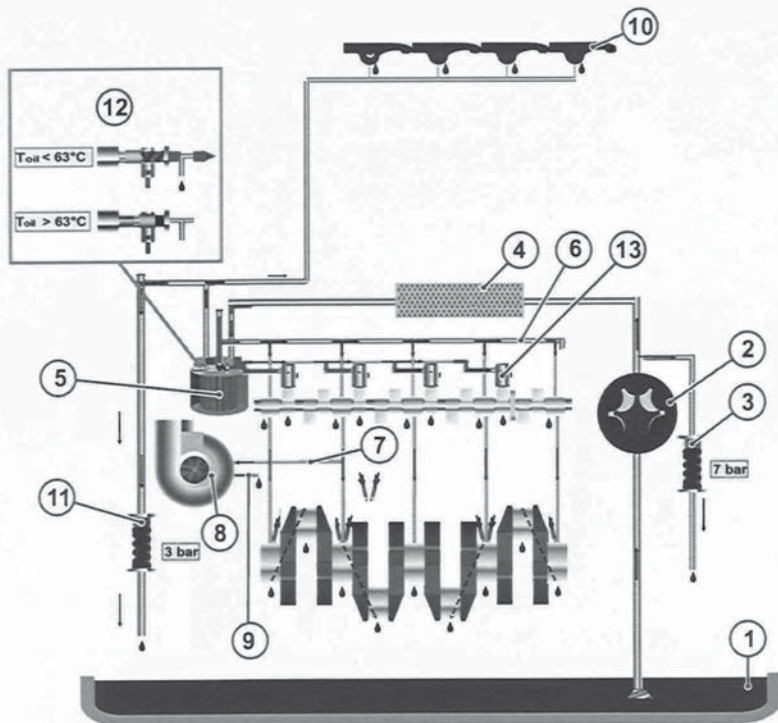

TD 2011 L04 w

(example)

- 1 Lubricating oil sump
 - 2 Lubricating oil pump
 - 3 Pressure limiting valve
 - 4 Lube oil cooler
 - 5 Lubricating oil filter
 - 6 Main lube oil channel
 - 7 Lubricating oil pipe to the turbocharger
 - 8 Turbocharger
 - 9 Lubricating oil return line from the exhaust turbocharger
 - 10 Rocker arm
 - 11 Pressure holding valve
 - 12 Lubricating oil filter console with integrated switching valve for controlling the hydraulic tappet. When the engine is cold, lubricating oil is fed to the hydraulic tappet.
 - 13 Hydraulic tappets
- To achieve early adjustment of the fuel injection in a cold start, the hydraulic tappets under the fuel injectors are supplied with lubricating oil.

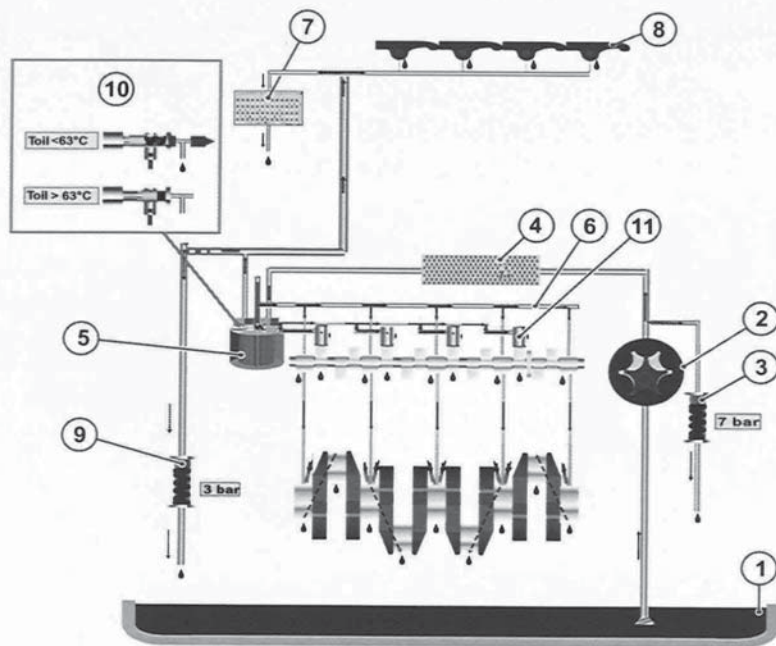

D 2011 w

Exhaust gas recirculation
(example)

- 1 Lubricating oil sump
- 2 Lubricating oil pump
- 3 Pressure limiting valve
- 4 Lube oil cooler
- 5 Lubricating oil filter
- 6 Cooling valve housing (exhaust gas recirculation)
- 7 Main lube oil channel
- 8 Rocker arm
- 9 Pressure holding valve
- 10 Lubricating oil filter console with integrated switching valve for controlling the hydraulic tappet. When the engine is cold, lubricating oil is fed to the hydraulic tappet. To achieve early adjustment of the fuel injection in a cold start, the hydraulic tappets under the fuel injectors are supplied with lubricating oil.
- 11 Hydraulic tappets

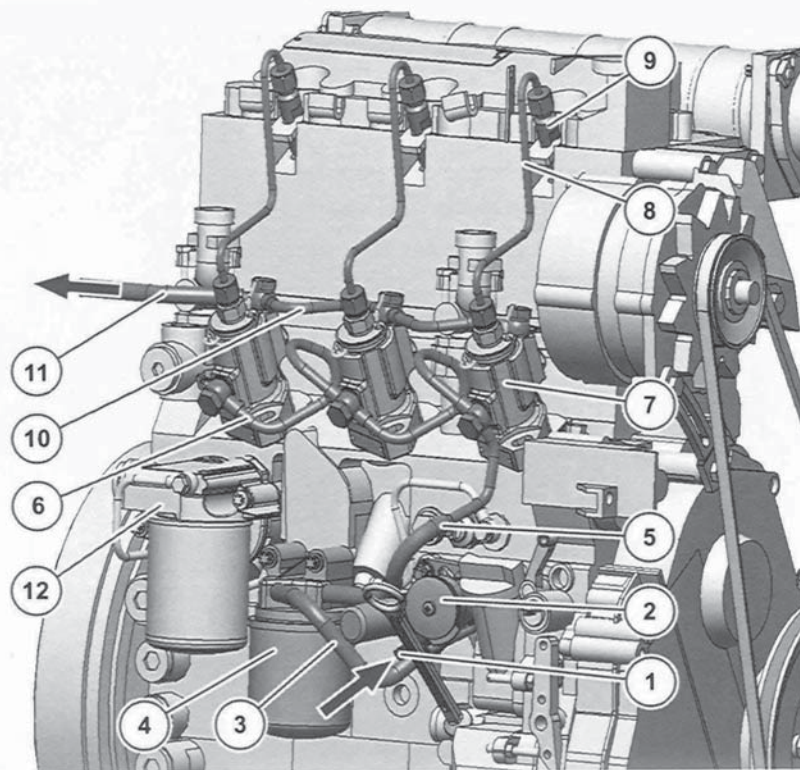

Fuel schematic (example)

- 1 Fuel line from tank to fuel pump
- 2 Fuel supply pump with integrated screen filter
- 3 Fuel pipe from the supply pump to the fuel change filter
- 4 Exchangeable fuel filter
- 5 Fuel pipe from the filter to the fuel injector
- 6 Fuel pipe to fuel injector
- 7 Injection pump
- 8 Injection line to injection valve
- 9 Injection valve
- 10 Return collection pipe
- 11 Fuel return to fuel tank
- 12 Lubricating oil filter console with integrated switching valve for controlling the hydraulic tappet. When the engine is cold, lubricating oil is fed to the hydraulic tappet. To achieve early adjustment of the fuel injection in a cold start, the hydraulic tappets under the fuel injectors are supplied with lubricating oil.

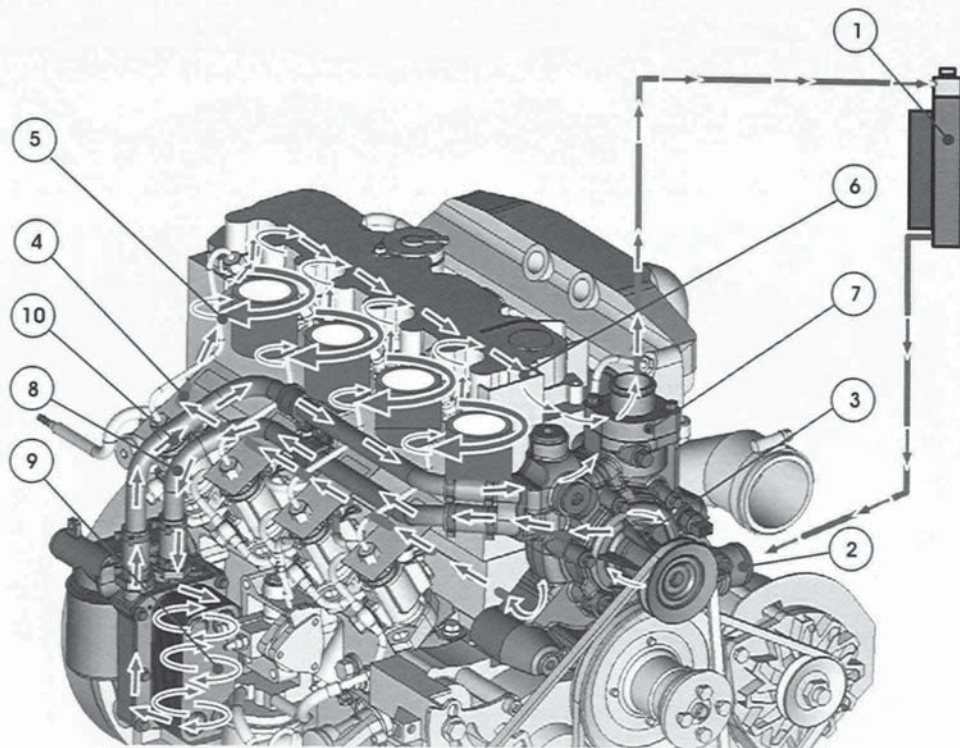

2

Coolant schematic (example)

D/TD/TCD 2011 w

- 1 Cooler
- 2 Coolant inlet
- 3 Coolant pump
- 4 Coolant supply for engine cooling
- 5 Cylinder pipe/head cooling
- 6 Coolant return to thermostat
- 7 Thermostat
(engine cold) coolant directly for engine cooling
(engine warm) coolant flow through the cooler

- 8 Coolant partial flow to the lubricating oil cooler
- 9 Lube oil cooler
- 10 Coolant return to thermostat

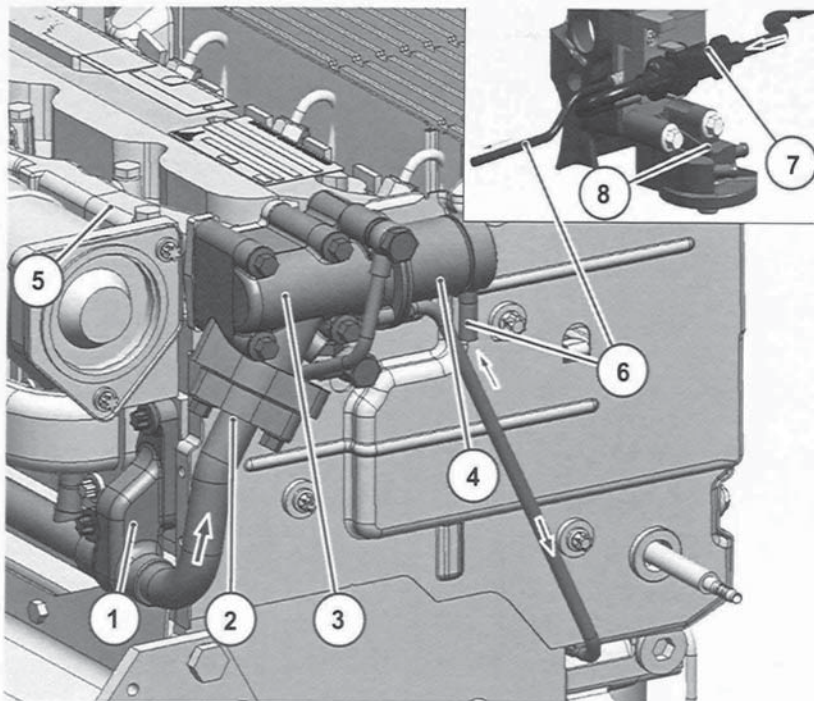

External exhaust gas recirculation
 D 2011 L04 i D 2011 L04 o D 2011 L04 w
 (example)

- 1 Exhaust gas partial flow (not connected)
- 2 Exhaust gas partial flow (connected)
- 3 Valve housing
- 4 Actuator (electrically actuated)
- 5 Distributor pipe
- 6 Electrical connection
- 7 Switch
- 8 Fuel filter console

The switch is connected internally with the control linkage. The voltage to the actuator is interrupted at load peaks.

The switch housing is designed to be safe from manipulation.

Only have work performed on the components by authorised qualified personnel.

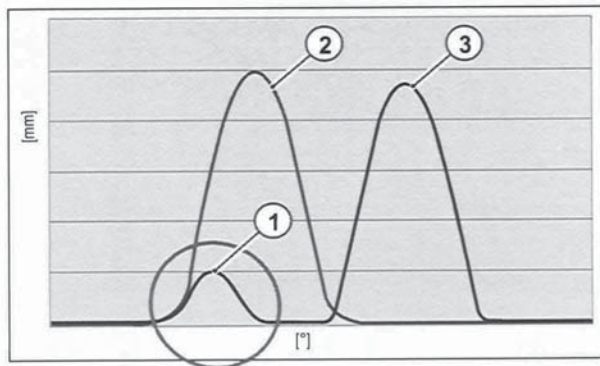
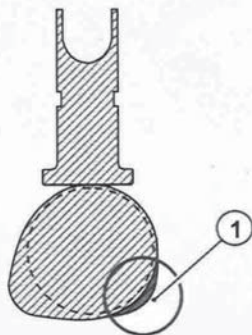

Internal exhaust gas recirculation

Engines with turbocharger

TD/TCD 2011

- 1 Additional cams for exhaust gas recirculation
Inlet valve opens briefly during the outlet cycle and emits an exhaust gas partial flow to the suction system. This partial volume is sucked back in in the next suction cycle.
- 2 Outlet valve
- 3 Inlet valve

Information about the engine electronics

This engine can be equipped optionally with an electronic DEUTZ control unit.

The equipping of the respective system depends on the desired scope of function and the planned type of engine application.

The resultant wiring with pin assignment can be seen in the appropriate wiring diagram.

The installation regulations of the DEUTZ AG must also be taken into account.

Precautions



The connections of the control units are only dust and water proof when the mating plugs are plugged (protection class IP69K)!

The control units must be protected against spray water and moisture until plugging in the mating plugs!

Reverse polarity can lead to failure of the control unit.

To avoid damaging the control units, all the connections on the control unit must be disconnected before electric welding work.

Interventions in the electrical system contrary to the DEUTZ regulations or by unqualified personnel can permanently damage the engine electronics and have serious consequences which are not covered by the manufacturer's guarantee.



It is strictly prohibited:

- to make changes or connections to the wiring of the electrical control devices and the data transmission cable (CAN lines).
- to switch control units.

Diagnostic and maintenance work may only be carried out by authorised personnel using equipment approved by DEUTZ.

Installation instructions

The control units are calibrated to the respective engine and identified by the engine number. Every engine may only be operated with the appropriate control unit.

Setpoint transmitters (pedal value transmitters) necessary for vehicle operation must be connected to the vehicle side cable harness and calibrated with the DEUTZ diagnostic program SERDIA (SERvice DIagnosis). Wiring and cable assignment of the vehicle side cable harness must be taken from the connection diagram of the DEUTZ installation consulting.

Supply voltage

DEUTZ diesel engines must be operated with a 12 V or 24 V supply. An adequate charging condition of the battery must be ensured. Interruption of the power supply when the engine is running can lead to damage to the electrics/electronics. Failure of the supply voltage leads to engine standstill.

Voltages above 32 Volt will destroy the control unit.

Diagnostics

DEUTZ control units are equipped with self-diagnostics. Active and passive error entries are saved in the error memory. Active errors are displayed by error lamp/diagnostic lamp (ⓘ 60). The active errors can be called by blink codes or by the DEUTZ diagnostic program SERDIA. Passive errors must be deleted by SERDIA.

- with error lamp (optional).
- via diagnostic socket (SERDIA).

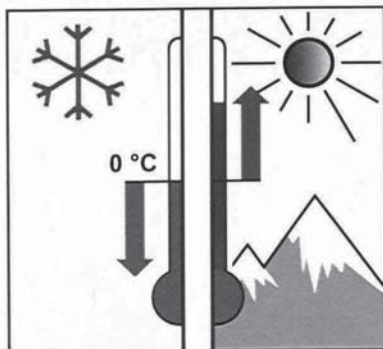

Low ambient temperatures

Lubricating oil

- Select the lubricating oil viscosity according to the ambient temperature.
- If cold starting occurs frequently cut the lube oil changing interval by half.

Fuel

- Use winter fuel below 0 °C (▣33).

Battery

- A good charging condition of the battery (▣53) is the prerequisite for starting the engine.
- Heating up the battery to approx. 20 °C improves the starting behaviour of the engine. (Remove and store the battery in a warm room).

Cold start aid

- Depending on the type of engine, glow plugs, heating plugs, heating flange, flame glow system can be used as cold starting aids. (▣27)

Coolant

D/TD/TCD 2011 w

- Observe the mixing ratio anti-freeze/cooling water. (▣34)

High ambient temperatures, high altitude



This engine can be equipped optionally with an electronic DEUTZ control unit. Under the operating conditions listed below, the amount of fuel is reduced automatically, controlled by the electronic control unit.

Under the following application and operating conditions, the amount of fuel must be reduced.

- above 1000 m altitude
- above 30 °C ambient temperature

Reason: Air density decreases as altitude or ambient temperature increase. This reduces the amount of oxygen in the engine intake air and the fuel-air mixture would be too rich if the injected amount of fuel were not reduced.

- The results would be:
 - black smoke in the exhaust
 - high engine temperature
 - reduction in engine performance
 - possible impairment of starting behaviour

Consult your equipment supplier or DEUTZ partner if you have any other questions.

Preparations for initial commissioning

(Maintenance schedule E 10)

- Remove engine corrosion protection
- Remove any transport devices.
- Check the battery and cable connections and mount if necessary.
- Check belt tension (▣ 49).
- Have the engine monitor or warning system checked by authorised personnel.
- Check the engine mounting.
- Check that all hose unions and clips fit properly.

The following additional work must be carried out on generally overhauled engines:

- Check the fuel pre-filter and main filter and change if necessary.
- Check the intake air cleaner (if available, maintain according to maintenance indicator).
- Drain lubricating oil and condensation water from the charge air cooler.
- Fill with engine lube oil.

D/TD/TC D 2011 w

- Fill the coolant system (▣ 65).

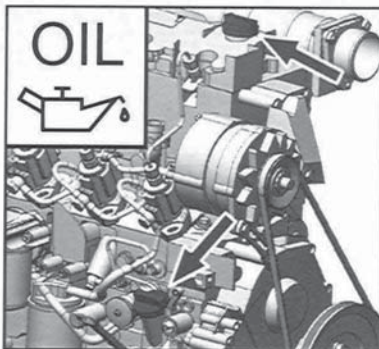

Fill with engine lube oil



Low lubricating oil level and overfilling lead to engine damage.



The engines are generally supplied without lubricating oil filling. Select lubricating oil quality and viscosity before filling. Order DEUTZ lubricating oils from your DEUTZ partner

- Fill the engine with lubricating oil via the lubricating oil filler neck.
- Observe the lubricating oil filling level (▣ 65).

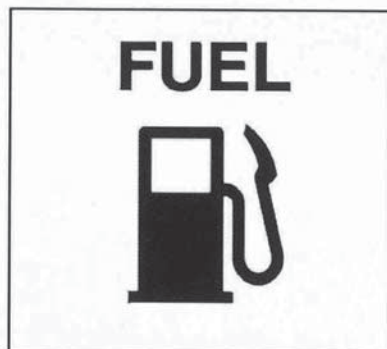

Pour in fuel



Only re-fuel when the engine is not running. Ensure cleanliness. Do not spill fuel. Additional venting of the fuel system by a 5 minute trial run at idle speed or on low load is absolutely essential.

- The fuel low pressure system must be vented before the first start-up after filling with the manually supply pump.

Only use clean commercially available brand diesel fuel. Observe fuel quality (▣ 33).

Use summer or winter-grade fuel, depending on the ambient temperature.

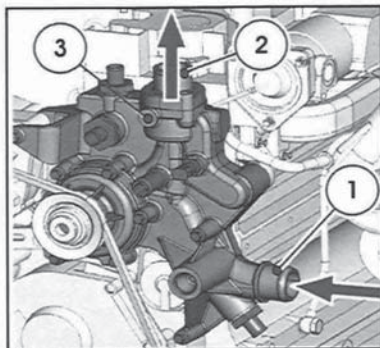

Filling the coolant system

D/TD/TCO 2011 w



The coolant must have a prescribed concentration of cooling system corrosion protection agent!
Never operate the engine without coolant, even for a short time!



Order coolant corrosion protection agent from your DEUTZ partner.

- Connect coolant outlet (2) and coolant inlet (1) to the cooling system. Connect the feed line of the compensation tank to the coolant pump or to the coolant inlet line (3).
- Connect ventilation line from the engine and, if necessary, from the cooler to the compensation tank.
- Fill cooling system via the compensation tank.

- Close compensation tank with valve.
- Start the engine and run up until the thermostat opens (line (2) heats up).
- Engine operation with open thermostat 2 - 3 minutes.
- Check the coolant level and top up coolant if necessary.



Danger of scalding from hot coolant!
Cooling system under pressure! Only open the cap when cool!
Observe safety regulations and national specifications when handling cooling media.

- If required, repeat procedure with engine start.
- Fill up coolant to the MAX mark on the compensation tank and close the cooling system cap.
- Switch on any available heating and set to the highest level so that the heating circuit is filled and vented.
- Observe the filling volume of the cooling system (ill 65).

Trial run



Additional venting of the fuel system by a 5 minute trial run at idle speed or on low load is absolutely essential.

Carry out a brief trial run up to operating temperature (approx. 90 °C) after preparations.

Do not load the engine if possible.

- Work with the engine not running:
 - Check engine for tightness.
 - Check lubricating oil level, if necessary top up.
 - Check the coolant level and top up coolant if necessary.
- Work during the trial run:
 - Check engine for tightness.

Starting



Before starting, make sure that nobody is standing in the immediate vicinity of the engine or work machine.

After repair work: Check that all guards have been replaced and that all tools have been removed from the engine.

When starting with the flame glow plug/glow plug/heating flange system do not use any other starting aid (e.g. injection with start pilot). Risk of accident!



If the engine fails to fire and the error lamp lights, the EMR2 has activated the start lock to protect the engine.

The start lock is released by switching off the system with the ignition key for about 30 seconds.

Do not actuate the starter for more than 20 seconds. If the engine does not start up, wait for one minute and then repeat the starting process.

If the engine does not start up after two attempts, determine the cause as per fault table (55).

Do not run up the engine immediately to high idling speed / full load operation from cold.



Disconnect the engine by uncoupling devices to be driven where possible.

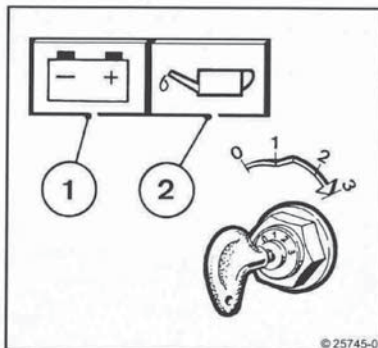

Without cold start aid

- Insert key.
- Turn key to the right.
 - Position 1 = operating voltage.
 - Pilot lamps (1) and (2) light up.
- Push the key in and turn further clockwise against spring pressure.
 - Level 2 = no function.
 - Level 3 = start.
- release the key as soon as the engine starts up.
 - The pilot lamps will go out.

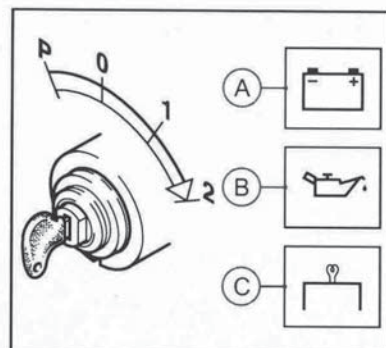

Glow plugs with cold start aid

- Insert key.
 - Position 0 = no operating voltage.
- Turn key to the right.
 - Position 1 = operating voltage.
 - Pilot lamps (A), (B) and (C) light up.
 - Preheat until the glow display goes out; an error has occurred if the preheating indicator flashes; e.g. the preheating relay is stuck, which can discharge the battery completely when at a standstill.
 - Engine is ready for operation.
- Push the key in and turn further clockwise against spring pressure.
 - Level 2 = start.
- release the key as soon as the engine starts up.
 - The pilot lamps will go out.

3

Operation monitoring by EMR2

Optional

The EMR2 system monitors the engine condition as well as the engine electronics and displays these to the driver/operator with the error lamp:

- **Function test**
 - Ignition on, error lamp lights up for approx. 2 seconds and then goes out.
- **The lamp does not light**
 - After the lamp test an extinguished lamp indicates an error-free and trouble-free operating state within the scope of the control possibility.
- **Steady light**
 - If a lamp lights steadily a monitored measuring variable (e.g. coolant temperature, lubricating oil pressure) has left the permissible value range.
- **Flashing**
 - Serious error in the system.

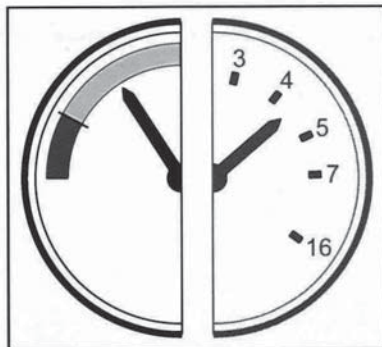









Display instrument

Possible displays:

- **Colour scale**
 - Display of operating state by coloured areas:
 - green = normal operating state
 - red = critical operating state
 - Take suitable action.
- **Measured value scale**
 - Actual value can be read off directly. The nominal value should be taken from the Technical Data (1065).

Instruments and symbols

Instruments/symbols	Designation	Possible display:	Measure
	Lubricating oil pressure display	Lubricating oil pressure below minimum	Switch off engine
	Lubricating oil pressure display	Lubricating oil pressure in the red area	Switch off engine
	D/TD/TCD 2011 w Coolant temperature	Coolant temperature too high	Switch off engine
	Lubricating oil pressure pilot lamp	If the pilot lamp lights up after starting the engine or while the engine is running, the lubricating oil pressure is too low	Switch off engine
	Lube oil level	If the pilot lamp lights up after starting the engine or while the engine is running, the lubricating oil level is too low	Fill up lube oil
	D/TD/TCD 2011 w Coolant level	If the control lamp lights up after the engine starts or while the engine is running, the coolant level is too low	Shut down the engine, allow to cool and top up coolant
	Operating hours counter	Indicates the previous operating time of the engine	Observe the maintenance intervals
	Horn	With acoustic signal	See fault table (55).

3

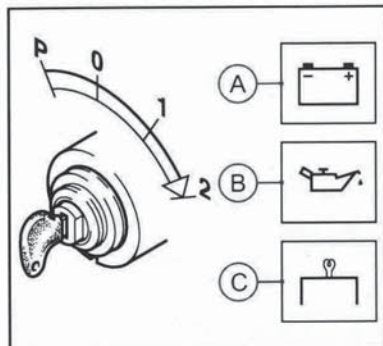

Shutting off

Electrical shutdown (optional)

- Move the key to position 0.
Control lamps A+B+C go out.
A = charge pilot light
B = lube oil pressure pilot light
C = pilot light for pre-heating system
P = gear position: park
0 = gear position: switch off engine
1 = gear position: pre-heat engine
2 = gear position: start engine



Avoid switching off from full load (coking/blockage of the remaining lubricating oil in the turbocharger bearing housing). The lubricating oil supply of the turbocharger is then no longer guaranteed! This shortens the life of the turbocharger.

Run the engine in low idling speed for approximately one minute after relieving the load.

The control unit remains active for about another 40 seconds to save the system data (lag) and then switches off automatically.

General

Modern diesel engines place very high demands on the lubricating oil to be used. The specific engine performances which have increased constantly over the last few years lead to an increased thermal load on the lubricating oil. The lubricating oil is also more exposed to contamination due to reduced oil consumption and longer oil change intervals. For this reason it is necessary to observe the requirements and recommendations described in this operating manual in order not to shorten the life of the engine.

Lubricating oils always consist of a base oil and an additive package. The most important tasks of a lubricating oil (e.g. wear protection, corrosion protection, neutralisation of acids from combustion products, prevention of coke and soot deposits on the engine parts) are assumed by the additives. The properties of the base oil are also decisive for the quality of the product, e.g. with regard to thermal load capacity.

In principle, all engine oils of the same specification can be mixed. However, mixing of engine oils should be avoided because the worst properties of the mixture are always dominant.

The lubricating oil quality has a considerable influence on the life, performance and thus also on the costs-effectiveness of the engine. It basically applies that: The better the lubricating oil quality, the better these properties.

The lubricating oil viscosity describes the flow behaviour of the lubricating oil depending on the temperature. The lubricating oil viscosity has no influence and effect on the lubricating oil quality.

Synthetic lubricating oils are used increasingly and have advantages. These oils have a better tem-

perature and oxidation stability as well as a relatively low cold viscosity. Since some processes relevant to the definition of the lube oil change intervals are not essentially dependent on the lube oil quality (such as the incorporation of soot and other contaminations), the lube oil change interval when using synthetic lube oils may not be increased in relation to the specifications of the lube oil change intervals.

Biodegradable lubricating oils may be used in DEUTZ engines if they meet the requirements of this operating manual.

Quality

Lubricating oils are classified by DEUTZ according to their efficiency and quality class (DQC: DEUTZ Quality Class). It basically applies that: with increasing quality class (DQC I, II, III, IV) the lubricating oils are more efficient and higher quality. The appended quality class designation (- 02 / - 05) indicates in which year the classification was made.

Lubricating oils according to other comparable specifications can be used as long as they meet DEUTZ requirements. In regions in which none of these qualities are available, please contact your responsible DEUTZ partner.

or see www.deutz.com >> SERVICE >> Operating Media and Diagnosis >> Deutz Quality Class >> DQC Release List (current edition)

Minimum quality class	
DEUTZ	Others
DQC I - 02	ACEA E2-96; API CF/CF-4
If the engine is operated with these lubricating oils, the lubricating oil change interval must be halved.	

The following lubricating oils are recommended for

the engines in this operating manual:

Recommended quality class	
DEUTZ	Others
DQC II - 05	ACEA E3-96/E5-02; API CH-4/CG-4; DHD-1
DQC III - 05	ACEA E4-99/E6-04
DQC IV - 05	Please contact your DEUTZ partner

DEUTZ lubricating oils DQC II-05 TLS - 15W40 D	
Container	Order number:
5 litre container	0101 6331
20 litre container	0101 6332
209 litre barrel	0101 6333

DEUTZ lubricating oils DQC III-05 TLX - 10W40 FE	
Container	Order number:
5 litre container	0101 6335
20 litre container	0101 6336
209 litre barrel	0101 6337

DEUTZ lubricating oils DQC IV-05 synthetic	
Container	Order number:
20 litre container	0101 7849
209 litre barrel	0101 7850

Lubricating oil change intervals

- The intervals depend on:
 - lubricating oil quality

- sulphur content in the fuel
- type of application of engine
- The lubricating oil change interval must be halved if at least one of the following conditions applies:
 - Constant ambient temperature below -10°C (14°F) or lube oil temperature below 60°C (84°F).
 - Sulphur content in the diesel fuel of 0.5-1 %. In case of fuels containing more than 1% sulphur, contact your corresponding DEUTZ partner.
 - operation with bio-diesel fuel
- If the lubricating oil change intervals are not reached within a year, the oil should be changed at least once a year.

Viscosity

The ambient temperature at the installation site or in the application area of the engine is decisive for choosing the right viscosity class. Too high a viscosity can lead to starting difficulties, too low a viscosity can endanger the lubrication effect and cause a high lubricating oil consumption. At ambient temperatures below -40°C , the lubricating oil must be pre-heated (e.g. by storing the vehicle or the machine in a hall).

The viscosity is classified according to SAE. Multi-purpose lubricating oils should be used basically. Single-purpose lubricating oils can also be used in enclosed, heated spaces at temperatures $>5^{\circ}\text{C}$.

Depending on the ambient temperature we recommend the following common viscosity classes:



The prescribed lubricating oil quality must be observed when selecting the viscosity class!

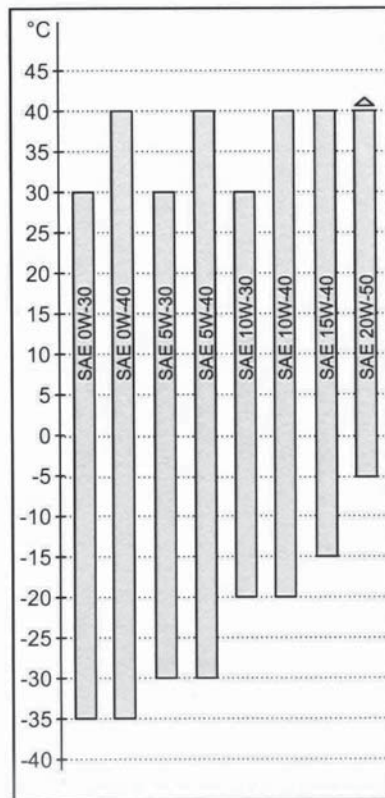

Permissible fuels

The following fuel specifications / standards are approved:

- Diesel fuels
 - EN 590
 - ASTM D 975 1-D
 - ASTM D 975 2-D
 - NATO F-54
 - JIS K2204 Grade 1
 - JIS K2204 Grade 2

Use commercially available fuels with a sulphur content below 0.5 %. The lubricating oil change intervals must be halved at a higher sulphur content.

If other fuels are used which do not meet the requirements of the operating manual, the warranty will be voided.

The certification measurements for compliance with the legal emission values are made with the test fuels specified in the laws. These correspond to the diesel fuels in accordance with EN 590 and ASTM D 975 described in the operation manual. No emission values are guaranteed with the other fuels described in this operation manual.

Winter operation with diesel fuel



Only carry out mixing in the tank. Fill with the appropriate amount of paraffin first, then add the diesel fuel. Normal and high grade fuels may not be mixed.

At low ambient temperatures paraffin discharges can lead to blockages in the fuel system and cause operating faults. Below 0 °C ambient temperature use winter diesel (down to -20 °C) (filling stations provide this in good time before the cold season starts).

- Below -20 °C paraffin should be added. The relevant percentages are given in the adjacent diagram.
- Special diesel fuels can be used for arctic climates to -44 °C.

If it is necessary to use Summer diesel fuel below 0 °C, up to 30 % petroleum can be added according to the diagram opposite.

Usually a sufficient cold resistance can be achieved by adding a flow improver. Ask your DEUTZ partner.

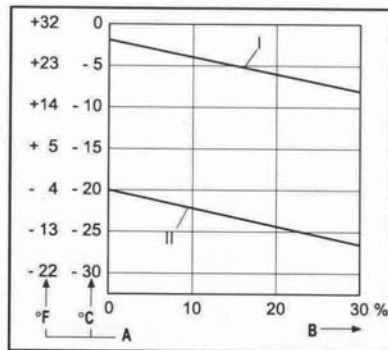

- I Summer-grade diesel fuel
- II Winter-grade diesel fuel
- A Outdoor temperature
- B Percentage of paraffin to be added

General



Never operate the engine without coolant, even for a short time!

D/TD/TC/D 2011 w

In liquid-cooled engines, the coolant must be conditioned and monitored, otherwise the engine could be damaged by:

- corrosion
- cavitation
- freezing

Water quality

The right water quality is important for conditioning the coolant. Clear, clean water within the following analysis values should always be used:

Analysis values		min	max	ASTM
ph value		6,5	8,5	D 1293
Chlorine (Cl)	[mg/l]	-	100	D 512 D 4327
Sulphate (SO ₄)	[mg/l]	-	100	D 516
Total hardness (CaCO ₃)	[mmol/l]	0,53	2,1	D 1126
	[mg/l]	53	213	
	[°dGH]	3,0	12,0	-

Specifications of the water quality are made by the local water board.

The water must be conditioned if it deviates from the analysis values.

- pH value too low:
Addition of diluted sodium or potassium lye.
Small trial mixtures are advisable.

- Total hardness too high:
Mixing with softened water (pH neutralized condensate or water softened by ion exchanger).
- Total hardness or carbonate hardness too low:
Mixing with harder water (harder water is usually available in the form of drinking water).
- Chlorides and/or sulphates too high:
Mixing with softened water (pH neutralized condensate or water softened by ion exchanger).

Cooling system corrosion protection agent



Health damaging nitrous amines form when nitrite-based cooling system corrosion protection agents are mixed with amine-based agents!



Cooling system corrosion protection agents must be disposed of in an environmentally friendly way.

The conditioning of the coolant for liquid-cooled DEUTZ compact engines is performed by mixing an anti-freeze with corrosion protection inhibitors based on ethylene glycol into the water.

DEUTZ cooling system corrosion protection agent

Container	Order number:
5 litre container	0101 1490
20 litre container	0116 4160
210 litre barrel	1221 1500

This cooling system corrosion protection agent is free from nitrite, amine and phosphate and is adapted

to the materials in our engines. Order from your DEUTZ partner.

Please contact your DEUTZ partner if the DEUTZ cooling system corrosion protection agent is not available.

The cooling system must be monitored regularly. This also includes checking the coolant system corrosion protection agent concentration in addition to checking the coolant level.

The cooling system corrosion protection agent concentration can be checked with conventional test instruments (e.g. refractometer).

Cooling system corrosion protection agent percentage	Water percentage	Cold protection up to
min. 35 %	65 %	-22 °C
40 %	60 %	-28 °C
max. 45 %	55 %	-35 °C

At temperatures below -35 °C, please contact your responsible DEUTZ partner.

It is possible to use other cooling system corrosion protection agents (e.g. chemical corrosion protection agents) in exceptional cases. Consult your DEUTZ partner.

Assignment of the DEUTZ maintenance and service schedules to maintenance intervals

Standard maintenance schedule D/TD/TCD 2011			
Stage	Activity	To be carried out by	Maintenance interval every operating hours (oh)
E10	Initial commissioning	Authorised specialists	When commissioning new or overhauled engines
E20	Daily inspection	Operator	1x daily or every 10 operating hours in continuous operation
E30	Maintenance	Qualified personnel	D: 1.000 ¹⁾ / TD/TCD: 500 ¹⁾
E40	Extended maintenance I		1000
E50	Extended maintenance II	Authorised specialists	3.000 ²⁾ / 5.000 ³⁾ / 6.000 ⁴⁾

EPA-certified engines

The EPA (Environmental Protection Agency) is a US Government organisation for the protection of the environment and human health.

Deviations from the standard maintenance schedule for engines subject to EPA certification			
Stage	Activity	To be carried out by	Maintenance interval every operating hours (oh)
E60	Intermediate overhaul	Authorised specialists	3.000

Observations			
1)	The lubricating oil load may be high depending on the application. The lubricating oil change interval must be halved here (31).		
	Toothed belt change intervals recommended values in op. h	Engine application example:	
2)	3,000 or max. 5 years	Agricultural machinery; skid steer loader; wheel loader; drilling machines; trench differs; joint cutters; excavators etc.	high speed; impact load; extreme ambient temperature; high dust load
3)	5,000 or max. 5 years	compressors; rollers; stackers; welding units; wheel loaders small dumpers; skid steer loaders, etc.	medium to high variable speed; high ambient temperature medium dust load
4)	6,000 or max. 5 years	Electrical units 1500/1800 rpm; pump units with low speed; lifting platforms; cooling aggregates etc.	low speed; medium ambient temperature low dust load

Maintenance measures

Stage	Activity	Measure	Page
E10		The measures are listed in chapter 3.	25
E20	Check	Lubricating oil level (if necessary top up)	38
		D/TD/TCD 2011 w Coolant level (top up if necessary)	26
		Engine tightness (visual inspection for leaks)	
		Suction air filter/dry air filter (maintain in accordance with maintenance indicator)	48
E30	Replace	Lubricating oil An lubricating oil application/change strategy adapted optimally to the individual engine application type can be created, for example, with the DEUTZ oil diagnosis. Ask your DEUTZ partner. Lubricating oil filter/insert (every time the lubricating oil is changed)	31/38 39
	Check	TD/TCD: Single checking and setting of the valve clearance if necessary at the first lubricating oil change	51
E40	Check	Heating plugs	
		D/TD/TCD 2011 w Coolant (additive concentration)	44
		Battery and cable connectors	53
		V-belts (retension or renew if necessary)	49
		Engine mounting (tighten, replace if damaged when necessary)	
		Fastenings, hose unions / clips (renew if damaged)	
	Settings	Valve clearance	51
	Replace	By-pass lubricating oil filter	
		Fuel filter cartridge	42
	Clean	Fuel pre-cleaner / fuel pre-filter (change filter insert if necessary)	41/43
Suction air filter/dry air filter (maintain in accordance with maintenance indicator)		48	
E50	Replace	Toothed belt	35
E60	Replace	Injection valve	
	Clean	Charge air cooler entry area (drain lube oil/condensate) Turbocharger compressor outlet	

Stage	Activity	Measure	Page
Every 2 years	Replace	V-belts	49
		Heating plugs	
		D/TD/TCD 2011 w Coolant	34 44

Maintenance work outside the DEUTZ maintenance and service schedules

*If the water level warning system (lamp/siren) responds, the fuel pre-filter must be emptied immediately.

Maintenance profile

A self-adhesive maintenance diagram is delivered with every engine. It should be stuck in a well visible location on the engine or equipment.

Order number: 0312 3538

Regulations for working on the lubricating oil system



Do not work when the engine is running! Smoking and naked lights prohibited! Be careful of hot lubricating oil. Danger of scalding!



Pay attention to utmost cleanliness when working on the lubricating oil system. Clean the area around the components concerned carefully. Blow damp parts dry with compressed air. Observe the safety regulations and national specifications for handling lube oils. Dispose of leaking lubricating oil and filter elements properly. Do not allow used oil to seep away into the ground. Perform a trial run after all work. Pay attention to tightness and lubricating oil pressure and then check the engine oil level. In case of fuels containing more than 1% sulphur, contact your corresponding DEUTZ partner.

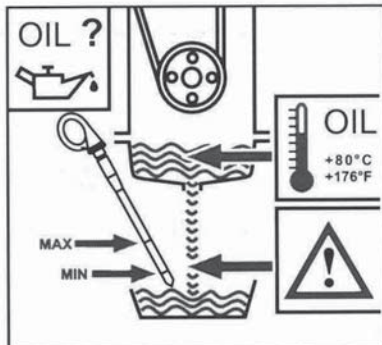

Checking the lubricating oil level



Low lubricating oil level and overfilling lead to engine damage. The lubricating oil level may only be checked with the engine in a horizontal position and switched off. If the engine is warm, switch off the engine and check the lubricating oil level after 5 minutes. If the engine is cold you can check it immediately.



Be careful of hot lubricating oil. Danger of scalding!

- Pull out the lubricating oil dipstick and wipe off with a lint-free, clean cloth.
- Insert the lubricating oil dipstick as far as it will go.
- Extract the lubricating oil dipstick and read off the oil level.

- The oil level must always be between the MIN and MAX marks! Top up to the MAX mark if necessary.

Changing the lubricating oil

- Warm up the engine (lubricating oil temperature > 80 °C).
- Ensure that the engine or vehicle is in a level position.
- Switch off the engine.
- Place a collecting receptacle underneath the lube oil drain screw.
- Unscrew the lube oil drain screw, drain oil.
- Fit a new sealing ring to the lube oil drain screw, insert and tighten. (tightening torque 100 Nm).
- Pour in lube oil.
 - Quality/viscosity data.
 - Filling volume (▮ 65).
- Warm up the engine (lubricating oil temperature > 80 °C).
- Ensure that the engine or vehicle is in a level position.
- Check lubricating oil level, if necessary top up.

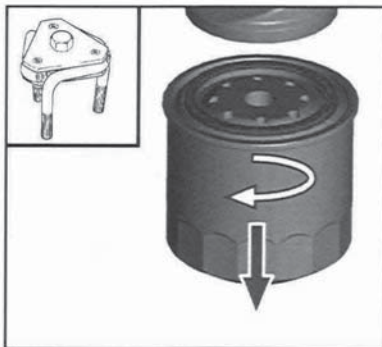

Change lubricating oil filter



The filter cartridge should never be pre-filled. There is a danger of dirt contamination!

- Remove clamps when twist protection mounted (optional).
- Loosen and unscrew filter cartridge with tool (order number: 170050).
- Collect draining lubricating oil
- Clean the sealing surface of the filter support with a lint-free, clean cloth.



- Oil the gasket of the new DEUTZ original filter cartridge lightly.
- Screw on new filter by hand until the gasket is in place and then tighten with a torque of 15-17 Nm.
- Fasten clamps of the twist protection (optional).

6

Specifications when working on the fuel system



Engine must be switched off!
Smoking and naked lights prohibited!
No injection/high pressure pipes may be disconnected while the engine is running.
Caution when handling hot fuel!
Pay attention to utmost cleanliness when refuelling and working on the fuel system.
Clean the respective affected parts carefully. Blow damp areas dry with compressed air.
Observe the safety regulations and national specifications for handling fuels.
Dispose of leaking fuel and filter elements properly. Do not allow fuel to seep away into the ground.
After all work on the fuel system, the system should be vented, a trial run performed and the tightness checked.
It will be necessary to vent the fuel system when commissioning for the first time, after maintenance work or if the tank has been run dry.



Additional venting of the fuel system by a 5 minute trial run at idle speed or on low load is absolutely essential.
Pay attention to utmost cleanliness due to the high production accuracy of the system!
The fuel system must be tight and closed.
Make a visual inspection for leaks/damage in the system.



Clean and dry the engine and engine compartment thoroughly before beginning work.
Areas of the engine compartment from which dirt could be loosened must be covered with a fresh, clean foil.
Work on the fuel system may only be carried out in an absolutely clean environment.
Contamination of the air such as dirt, dust, moisture etc. must be avoided.

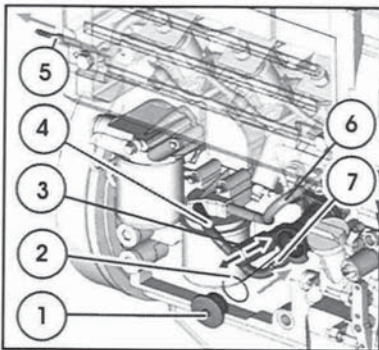

Fuel supply pump, sieve filter cartridge clean/change

Vent the fuel system

- Pump in the direction of the arrow (3) until a strong resistance is felt and pressure has built up.
- The return line (5) must be filled.
- Start the engine and run in idle or on low load. Air is pressed through the return pipe (5) to the tank.

- Close fuel shutoff tap (with high-level tank) (supply (7)).
- Remove connection (4) to the fuel filter.
- Catch any escaping fuel.
- Loosen screw (1).
- Remove fuel screen (screw (1), cover and fuel screen form one unit).
- Take the sealing ring (2) and clean it, renew when damaged.
- Clean cover-fuel screen with fuel, renew depending on the condition.
- Put the sealing ring (2) in position.
- Mount the cover-fuel filter with screw (1).
- Reinstall connection (4) to the fuel filter.
- Open fuel shutoff tap supply (7), start engine and run in idle or on low load.
- Check for leaks after starting the engine.

6

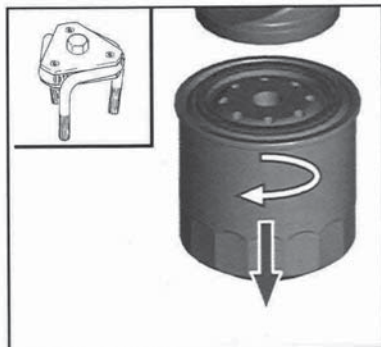

Change the fuel filter cartridge



The filter cartridge should never be pre-filled. There is a danger of dirt contamination!

- Remove clamps when twist protection mounted (optional).
- Loosen and unscrew filter cartridge with tool (order number: 170050).
- Catch any escaping fuel.
- Clean the sealing surface of the filter support with a lint-free, clean cloth.

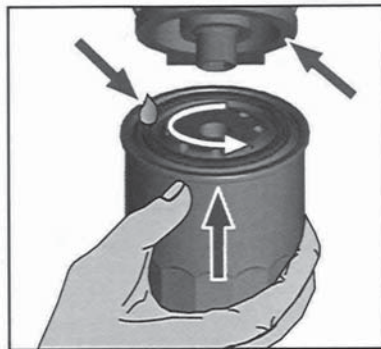

- Oil the gasket of the new DEUTZ original filter cartridge lightly.
- Screw on new filter by hand until the gasket is in place and then tighten with a torque of 10-12 Nm.
- Fasten clamps of the twist protection (optional).
- Vent the fuel system.

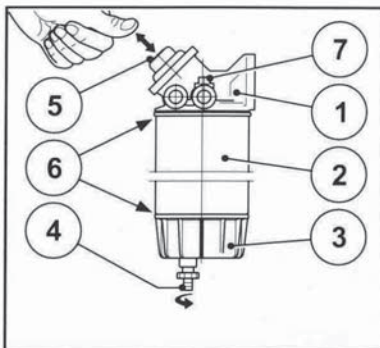

Clean/change/vent the fuel pre-filter

- 1 Fuel pre-filter holder
- 2 Fuel filter insert
- 3 Water collection vessel
- 4 Water drain tap
- 5 Fuel pump
- 6 Sealing surface
- 7 Venting screw

- Shut off the fuel supply to the engine (with high-level tank).
- Place a vessel under the drain plug.
- Open the drain tap (4) and drain off the liquid.
- Unscrew the filter insert (2) together with the water collection vessel (3).
- Empty emulsion in the water collection vessel (3) and clean the vessel.
- Mount the filter insert (2) and water collection vessel (3). Wet the sealing surfaces (6) of the filter insert (2) and the water collection vessel (3)

with fuel.

- Assembly in clockwise direction.
- Open the fuel shutoff tap and vent the system, see venting the fuel system.
- Start engine.
- Check for leaks after starting the engine.

Change the fuel pre-filter insert

- Shut off the fuel supply to the engine (with high-level tank).
- Place a vessel under the drain plug.
- Open the drain tap (4) and drain off the liquid.
- Unscrew the filter insert (2) together with the water collection vessel (3).
- Unscrew the water collection vessel (3) from the filter insert (2).
 - The special tool can be ordered under part number 8192 (☐ 70).
- Clean the water collection vessel (3) and all the existing sealing surfaces (6) with a brush and diesel fuel.
- Oil the gaskets and sealing surfaces (6) of the new DEUTZ original filter insert (2) lightly or wet with diesel fuel.
- Screw the water collection vessel (3) to the filter insert (2).
- Screw a new filter insert (2) with water collection vessel (3) onto the filter carrier (1) (tightening torque 17-18 Nm)
- Open the fuel supply to the engine.
- Vent the fuel system.

Vent the fuel pre-filter.

- Loosen the venting screw (7) slightly.
- Operate the pump until fuel emerges without

bubbles.

- Catch any escaping fuel.
- Tighten the venting screw (7).

Vent the fuel system

- Bring engine control to stop position.
- Position fuel collecting vessel below the constant-pressure valve in the crankcase/filter housing.
- Open constant-pressure valve in the crankcase/filter stopcock in the filter housing.
- Turn over the engine with starter (max. 20 Sec.) until bubble-free fuel emerges at the constant-pressure valve in the crankcase/filter housing.
- Screw in ventilation screws (tightening torque 25-5 Nm) and constant-pressure valve.
- Bring engine control to the start position and start.
- Check for leaks after starting the engine.

Specifications when working on the cooling system

D/TD/TC/D 2011 w



Danger of scalding from hot coolant!
Cooling system under pressure! Only open the cap when cool!
The coolant must have a prescribed concentration of cooling system corrosion protection agent!
Observe safety regulations and national specifications when handling cooling media.
Observe the manufacturer's specifications for an external cooler.
Dispose of leaking liquids properly and do not allow them to seep into the ground.
Order coolant corrosion protection agent from your DEUTZ partner.
Never operate the engine without coolant, even for a short time!

Checking the coolant level with an external cooler

D/TD/TC/D 2011 w

- Fill in new coolant and vent the system according to the specifications of the cooling system manufacturer.
- Open the cooling system cap (1) carefully.
- The coolant level must always be between the MIN and MAX marks of the compensation tank! Fill up to the MAX mark if necessary.

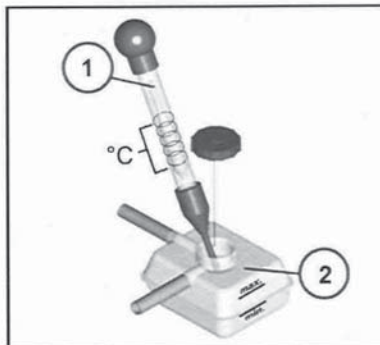

Check coolant additive concentration

D/TD/TC/D 2011 w

- Open the cooling system cap (1) carefully.
- Check the coolant additive concentration in the cooler/compensation tank (2) with a conventional antifreeze measuring device (1) (e.g. hydrometer, refractometer).
- Necessary coolant additive concentration: Coolant mixing ratio (34).

You can order the appropriate test instrument from your DEUTZ partner under order number 1824.

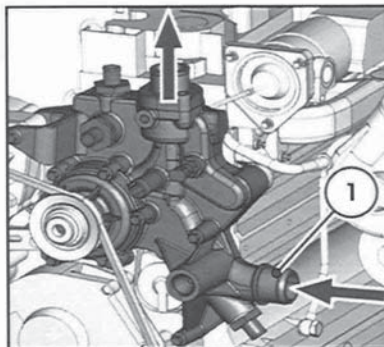

Emptying the cooling system

D/TD/TC/D 2011 w

- Open cooler locking cap carefully.
- Place a collection tray underneath the coolant connection (1).
- Drain coolant.
- Reconnect and tighten the coolant connection (1).
- If the locking screw is not accessible, the drainage can be carried out at the engine oil cooler (coolant duct).
- Close cooler locking cap.

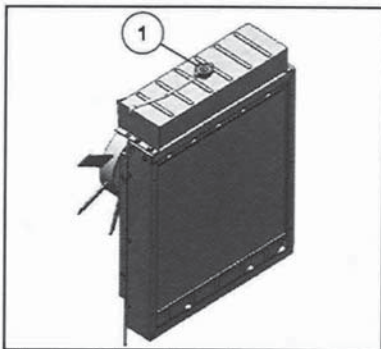

Fill and ventilate cooling system

tion tank if necessary.



Danger of scalding from hot coolant!
Cooling system under pressure! Only open
the cap when cool!

D/TD/TCO 2011 w

- Open the cooling system cap (1) carefully.
- Loosen the cooler venting screw if necessary.
- Fill coolant up to the max. mark or filling limit.
- Switch on any available heating and set to the highest level so that the heating circuit is filled and vented.
- Close the cooler venting screw.
- Close cooler locking cap.
- Run engine up to operating temperature (opening temperature of the thermostat).
- Switch off the engine.
- Check coolant level in cooled engine and top up to the MAX mark or filling level on the compensa-

Cleaning work



For all cleaning work, make sure that no parts are damaged (e.g. bent cooler mesh). Cover electrical/electronic parts and connections to clean the engine (e.g. control units, generator, solenoid valves etc.). Do not aim the water/steam jet directly at them. Allow engine to warm up.



Only carry out cleaning work on the engine when it is not running!
Remove the engine cover and cooling air cover if available and remount after cleaning.

General

The following causes of soiling make it necessary to clean the engine:

- High dust content in the air.
- Chaff and chopped straw in the area of the engine.
- Coolant leaks
- Lubricating oil leakage
- Fuel leaks

Because of the different application conditions, cleaning depends on the degree of dirt contamination.

Cleaning with compressed air

- Blow dirt off or out. Always blow out the cooler and cooling fins from the exhaust air side to the fresh air side.

Cleaning with cold cleaner

- Spray the engine with cold cleaner and leave it for about 10 minutes to take effect.
- Spray the engine clean with a high pressure water jet.
- Warm up the engine so that the water residues evaporate.

Cleaning with a high pressure cleaner

- Clean the engine with a steam jet (maximum spray pressure 60 bar, maximum steam temperature 90 °C, distance at least 1m).
- Warm up the engine so that the water residues evaporate.
- Always clean the cooler and cooling fins from the exhaust air side to the fresh air side.

Regulations for working on the intake system



Do not work when the engine is running!



Pay attention to utmost cleanliness when working on the intake system, close intake openings if necessary. Dispose of old filter elements properly.

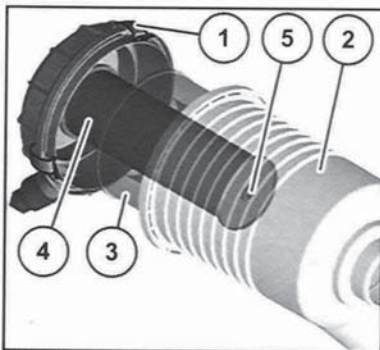

Maintaining the dry air filter



Do not clean the filter element (3) with petrol or hot liquids!
Renew damaged filter elements.

- Maintain the filter element (3) according to the interval in the maintenance schedule
- Lift up the clamping yoke (1).
- Remove the filter hood (2) and pull out the filter element (3).
- Filter element (3):
 - blow out with dry compressed air (max. 5 bar) from the inside to the outside if soiling is only slight,
 - renew if heavily soiled.

Renewing the safety cartridge of the dry air filter



Never clean the safety cartridge (4).

- Renew safety cartridge (4) according to the interval in the maintenance schedule
- To do this:
 - Unscrew hexagon nut (5), pull out safety cartridge (4).
 - Insert new safety cartridge, screw on hexagonal nut.
- Insert filter element (3), mount hood (2) and fix with clamping yoke (1).

6

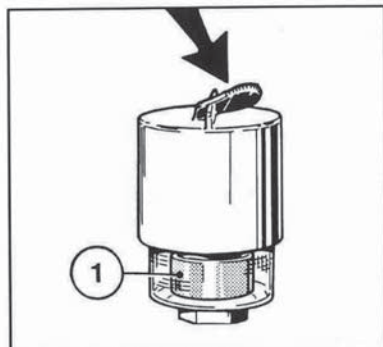

Maintenance indicators for dry air filter

- The dry air filter is maintained according to a maintenance switch or maintenance indicator.
- Maintenance is necessary when:
 - the yellow warning light of the **maintenance switch** lights up when the engine is running.
 - the red field (1) of the **maintenance indicator** is fully visible.
- After carrying out maintenance work, reset the signal by pressing the button on the maintenance indicator. The maintenance indicator is now ready for operation again.

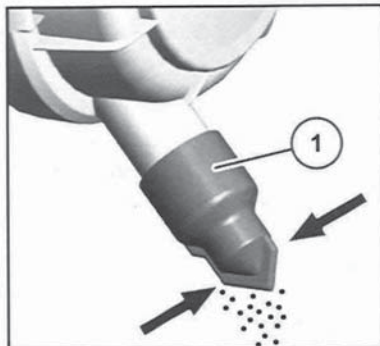

Clean the dust discharge valve of the dry air filter

- Empty the dust discharge valve (1) by pressing together the discharge slit.
- Remove any caked dust by pressing together the upper section of the valve.
- Clean the discharge slit.

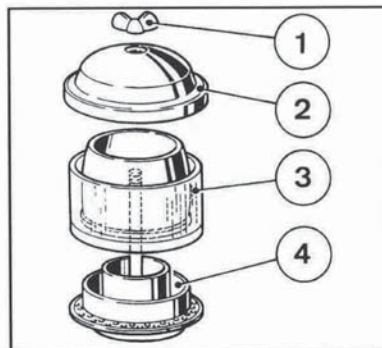

Emptying the cyclone pre-cleaner



Never fill the dust container (3) with lubricating oil!

- Loosen wing nut (1) and lift off housing cover (2).
- Remove the dust container (3) from the base (4) and empty it. Clean the container using a brush and clean diesel fuel. Then dry.
- Place the dust container (3) on the base (4) and tighten the housing cover (2) with wing nut (1).

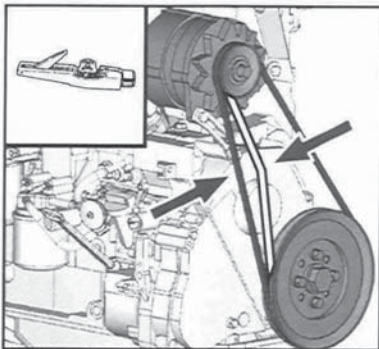

Checking the belt drive



Only carry out work on the belt drive with the engine at a standstill!
Always change both belts in sets in case of wear on the double belts or damage to one V-belt.

After repair work: Check that all guards have been replaced and that all tools have been removed from the engine.

- Check the whole belt drive visually for damage.
- Renew damaged parts.
- Remount protective devices if necessary.
- Pay attention to correct fit of new belts, check the tension after running for 15 minutes.

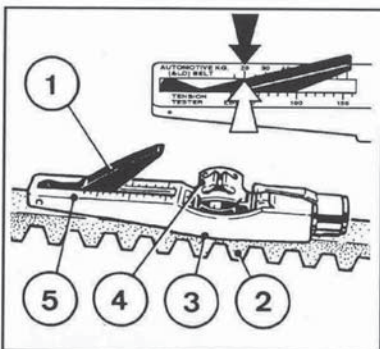

Checking the belt tension

- Lower indicator arm (1) into the measuring device.
- Place guide (3) between two belt pulleys on the V-belt (2). The stop have to be at the side.
- Press the button (4) at right angles to the V-belt (2) evenly until you hear or feel the spring snap in.
- Lift the measuring device carefully without altering the position of the indicator arm (1).
- Read the measured value at the point of intersection (arrow), scale (5) and indicator arm (1).
- If necessary, re-tension belt and measure again.

Tools

Belt tension measuring device (order number: 8115) can be obtained from your DEUTZ partner.

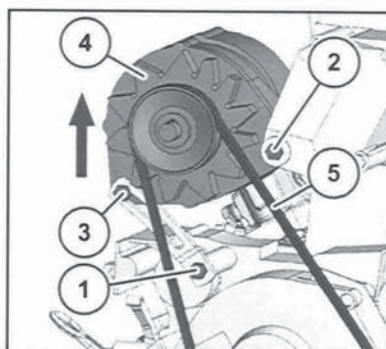

Tighten the generator V-belts

- Loosen the screw (1), (2) and (3) slightly.
- Push the generator (4) outwards in the direction of the arrow until you get the correct V-belt tension.
- Retighten the screw (1), (2) and (3).

Renew the V-belts

- Loosen the screw (1), (2) and (3) slightly.
- Swing the generator (4) in in the opposite direction to the arrow.
- Remove the V-belt (5) and fit a new V-belt.
- Push the generator (4) outwards in the direction of the arrow until you get the correct V-belt tension.
- Retighten the screw (1), (2) and (3).

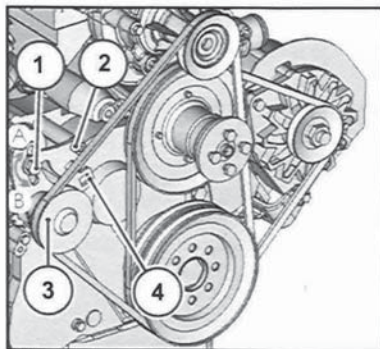
**Tighten belt**

- Loosen screws (1) and (2) and (3).
- Plug socket wrench insert of the torque wrench into the opening (4) of the tensioning pulley (3).
- Move the tensioning pulley (3) with the torque wrench in the direction of the arrow (A) until the correct belt tension is reached.
- Retighten the screws (1) and (2).
- Checking the belt tension (▣ 65).

Change the belt

- Loosen screws (1) and (2) and (3).
- Move the tensioning pulley (3) in the direction of the arrow (B).
- Remove belt and fit new one.
- Plug socket wrench insert of the torque wrench into the opening (4) of the tensioning pulley (3).
- Move the tensioning pulley (3) with the torque wrench in the direction of the arrow (A) until the correct belt tension is reached.

- Retighten the screws (1) and (2).
- Checking the belt tension (▣ 65).

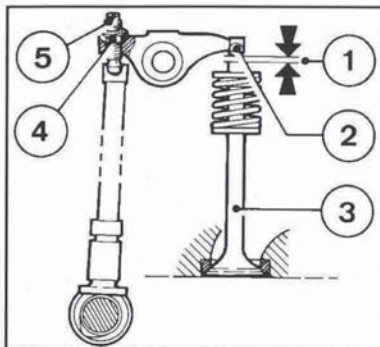

Check valve clearance, adjust if necessary

- Let the engine cool down for at least 30 minutes before setting the valve clearance: Lubricating oil temperature below 80 °C.
- Remove the cylinder head hood.
- Place turning gear over fastening screws of the belt pulleys.
- Turn the crankcase until reaching valve overlap.
Outlet valve is not yet closed, inlet valve begins to open.
The cylinders to be set can be seen in the setting schematic.
- Check the valve clearance (1) between the rocker arm lugs (2) and the valve (3) with a feeler gauge (6).
- The feeler gauge (6) must slide in with little resistance.
- For permissible valve clearance, see (▣ 65)
- Adjust valve clearance if necessary:

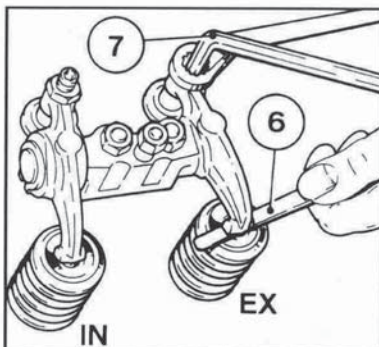

- Engage hexagon socket head wrench (7) and insert and loosen the lock nut (4).
- Adjust the valve clearance setting screw (5) with the hexagon socket head wrench (7) so that the correct valve clearance (1) is reached after tightening the lock nut (4).
- Perform the setting procedure on every cylinder.
- Reinstall cylinder head cover, with new gasket.

Valve clearance setting schematic

Engines with turbocharger
TD/TCD 2011



This engine is equipped with an internal exhaust feedback system.
The inlet valve opens briefly in the out stroke.
Do not confuse this with the valve overlap!

Valve overlap	Settings
Cylinders	Cylinders
1	4
3	2
4	1
2	3

6

1

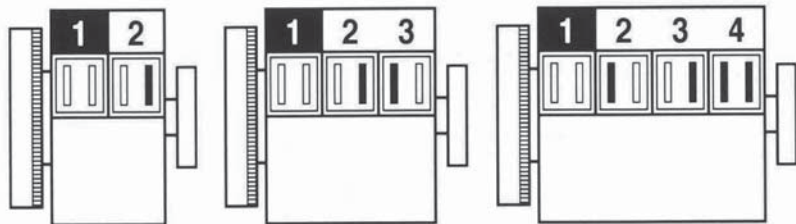

2

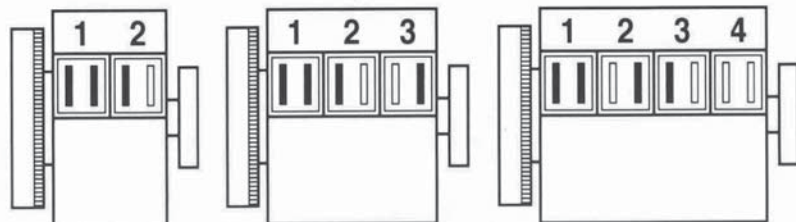

Valve clearance setting schematic

Suction motor

D 2011

- **Crankshaft position 1**

Turn crankshaft until both valves overlap on the cylinder.

Outlet valve is not yet closed, inlet valve begins to open.

Setblack marked valves.

Mark the respective rocker arm with chalk to check the setting you have made.

- **Crankshaft position 2**

Turn the crankshaft one turn (360°).

Setblack marked valves.

Regulations for working on the electrical system



Do not touch the voltage conducting parts, faulty warning lamps should be immediately replaced.



Pay attention to correct polarity of the connections.

Cover electrical/electronic parts and connections to clean the engine (e.g. control units, generator, solenoid valves etc.). Do not aim the water/steam jet directly at them. Allow engine to warm up.

Touching a lead against the frame to check whether it is live must not, under any circumstances, be carried out.

For electrical welding work, the ground terminal of the welding gear must be clamped directly to the part being welded.

Three-phase current generator: Never disconnect the cables between battery, generator and regulator while the engine is running.

Battery



Electronically stored data could be lost if the battery is disconnected.

Keep battery clean and dry.

Make sure the battery is fitted correctly and securely.

Dispose of old batteries in an environmentally friendly way.



Danger of explosion! The gases emitted by the battery are explosive!

Fire, sparks, smoking and naked lights are prohibited!

Danger of acid burns! Wear protective gloves and glasses! Avoid contact with skin and clothing!

Danger of short circuit! Do not rest tools on the battery!

Checking the voltage

- Check the battery voltage with a conventional voltmeter. The voltage indicates the charging state. It should be between 12 and 14.4 Volt depending per battery.

Check acid level

- Unscrew caps.
- Note the manufacturer's specifications concerning the liquid level.
The liquid should normally be 10-15 mm above the top edge of the plate or reach up to any available control device.
- Only use distilled water to top up the battery.
- Screw in caps.

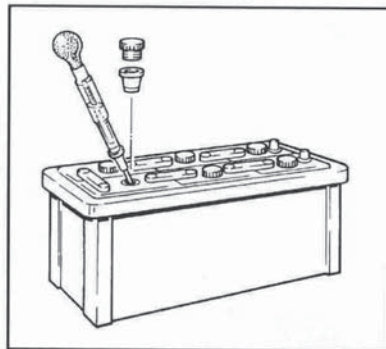

Check acid density

- Unscrew caps.
- Measure the electrolyte density of individual cells with a commercial hydrometer. Hydrometer reading indicates battery's state of charge. The acid temperature when measuring should be 20 °C if possible.
- Check the acid level before recharging.
- Screw in caps.

Acid density [kg/ l]		Charge status	Measure
Normal	Tropical		
1,28	1,23	good	none
1,20	1,12	half	charge
1,12	1,08	empty	charge

Removing the battery

- Always disconnect the minus pole first when removing the battery. Otherwise there is a danger

6

of short-circuit!

- Remove the fastenings and take out the battery.

Charging the battery

- Unscrew caps.
- Charge the battery with a conventional battery charger. Observe the manufacturer specifications!
- Screw in caps.

Installing the battery

- Insert new or charged battery and attach the fastenings.
- Clean the terminals and battery poles with fine emery paper.
- Connect the plus pole first and then the minus pole. Otherwise there is a danger of short-circuit! Make sure the terminals have good contact. Tighten clamp bolts hand-tight.
- Grease the assembled terminals with an acid-free, acid-resistant grease.

Faults and remedies

Faults	Causes	Measures
Engine does not start or is difficult to start	Not disconnected (if possible)	Check coupling
	Below starting limit temperature	Check
	Wrong SAE viscosity class of the engine lubricating oil	Change the lubricating oil
	Fuel quality does not comply with operating manual	Change the fuel
	Battery defective or discharged	Check battery
	Cable connection to starter loose or oxidized	Check cable connections
	Starter defective or pinion does not engage	Check starter
	Stop magnet defective (release circuit)	Check lifting magnet
	Engine stop lever still in stop position	Check/replace
	Stop magnet defective (release circuit)	Check/replace
	Incorrect valve clearance	Check valve clearance and set if necessary
	Injection valve defective	Check fuel injector / change if necessary
	Air filter clogged / turbocharger defective	Check/replace
	Air in fuel system	Vent fuel system
	Compression pressure too low	Check compression pressure
Exhaust gas backpressure too high	Check	
Injection line leaks	Check injection line	
Engine does not start and diagnostic lamp flashes	Engine electronics prevents starting	Check error according to error code and eliminate error if necessary

Faults	Causes	Measures
Engine starts, but runs irregularly or fails	Belt/V-rib belt (fuel pump in belt drive)	Check whether torn or loose
	Incorrect valve clearance	Check valve clearance and set if necessary
	Compression pressure too low	Check compression pressure
	Glow plugs defective	Change
	Air in fuel system	Vent
	Fuel filter contaminated	Clean
	Fuel quality does not comply with operating manual	Change the fuel
	Injection valve defective	Check fuel injector / change if necessary
	Injection line leaks	Check injection line
Speed changes are possible and diagnostic lamp lights up	Engine electronics has detected a system error and activates an equivalent speed	Check error according to error code and eliminate error if necessary

Faults	Causes	Measures
Engine becomes excessively hot. Temperature warning system activates	Vent line blocked	Clean
	Wrong SAE viscosity class of the engine lubricating oil	Change the lubricating oil
	Lubricating oil cooler fins soiled	Clean
	Lube oil filter contaminated on the air or lube oil side	Change
	Lube oil level too high	Check lube oil level, if necessary drain off.
	Lubricating oil level too low	Fill up lube oil
	Incorrect valve clearance	Check valve clearance and set if necessary
	Stop magnet defective (release circuit)	Check lifting magnet
	Coolant heat exchanger soiled	Clean
	Defective cooling water pump (torn or loose V-belt)	Check whether torn or loose
	Low coolant	Fill up
	Resistance in cooling system is too high / flow volume too low	Check the cooling system
	Cooling fan or exhaust thermostat defective, V-belt torn or loose	Check/replace/tension
	Heat short-circuit in the cooling air guidance	Check the cooling system
	Charge air line leaking	Check charge air line
	Charge air cooler soiled	Check/clean
	Air filter clogged / turbocharger defective	Check/replace
	Air filter maintenance switch / maintenance indicator defective	Check/replace
	Fan defective/V-belt torn or loose	Check fan/V-belt, change if necessary

Faults	Causes	Measures
Engine output is deficient	Lube oil level too high	Check lube oil level, if necessary drain off.
	Lubricating oil level too low	Fill up lube oil
	Lubricating oil cooler fins soiled	Clean
	Engine stop lever still in stop position	Stop magnet defective (release circuit)
	Fuel quality does not comply with operating manual	Change the fuel
	Air filter clogged / turbocharger defective	Check/replace
	Air filter maintenance switch / maintenance indicator defective	Check/replace
	Fan defective/V-rib belt torn or loose	Check fan/V-belt, change if necessary
	Charge air line leaking	Check charge air line
	Charge air cooler soiled	Clean
	Heat short-circuit in the cooling air guidance	Check the cooling system
	Resistance in cooling system is too high / flow volume too low	Check the cooling system
	Injection line leaks	Check injection line
Injection valve defective	Check fuel injector	
Engine performs poorly and diagnostic lamp lights	Engine electronics reduce performance	Check error according to error code and eliminate error if necessary
Engine does not run on all cylinders	Injection line leaks	Check injection line
	Injection valve defective	Check fuel injector / change if necessary
	Charge air line leaking	Check charge air line
	Lube oil level too high	Check lube oil level, if necessary drain off.
	Air filter clogged / turbocharger defective	Check/replace
	Air filter maintenance switch / maintenance indicator defective	Check/replace
	Fuel quality does not comply with operating manual	Change the fuel
Engine lubricating oil pressure is non-existent or excessively low	Lubricating oil level too low	Fill up lube oil
	Excessive inclination of engine	Check engine mounting / reduce inclination
	Wrong SAE viscosity class of the engine lubricating oil	Change the lubricating oil

Faults	Causes	Measures
Engine lubricating oil consumption excessive	Lube oil level too high	Check lube oil level, if necessary drain off.
	Excessive inclination of engine	Check engine mounting / reduce inclination
Lubricating oil in the exhaust system	Engine operated continuously with too low a load (< 20-30%)	Check load factor
Engine producing blue smoke	Lube oil level too high	Check lube oil level, if necessary drain off.
	Excessive inclination of engine	Check engine mounting / reduce inclination
Engine producing white smoke	Below starting limit temperature	Check
	Incorrect valve clearance	Check valve clearance and set if necessary
	Fuel quality does not comply with operating manual	Change the fuel
	Injection valve defective	Check fuel injector / change if necessary
Engine producing black smoke	Air filter clogged / turbocharger defective	Check/replace
	Air filter maintenance switch / maintenance indicator defective	Check/replace
	Charge air pressure-dependent full load stop defective	Check
	Incorrect valve clearance	Check valve clearance and set if necessary
	Charge air line leaking	Check charge air line
	Injection valve defective	Check fuel injector / change if necessary

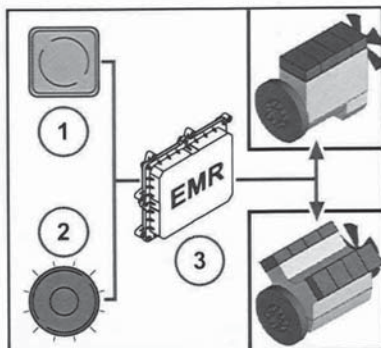

Engine protection function of the EMR2 system

Optional

Depending on the design of the monitoring functions, the EMR2 system (3) can protect the engine in certain problematical situations by monitoring important limit values during operation and checking the correct function of the system components.

Diagnostic key and error lamp

The diagnostic key (1) and the error lamp (2) are accommodated in the vehicle drive stand. The blink-code release can be activated using the diagnostic key (1).

The error lamp can release the following signals:

- Function test
 - Ignition on, error lamp lights up for approx. 2 seconds and then goes out.
 - Check the error lamp if there is no reaction after switching on the ignition.
- The lamp does not light
 - After the lamp test an extinguished lamp indicates an error-free and trouble-free operating state within the scope of the control possibility.
- Steady light
 - Error in the system.
 - Operation continued with restrictions.
 - The engine must be checked by a DEUTZ partner.
- Flashing
 - Serious error in the system.
 - The engine has reached switch-off condition.
 - The switch-off process has been accomplished.
- Blink code
 - Errors that may occur can be classified.
 - The blink codes can only be interpreted by a DEUTZ partner.

The flashing error lamp may have the following meaning depending on the engine configuration:

- Switch off prompt for the operator. Attention: Failure to do so will lead to loss of guarantee!
- Automatic shutdown of the engine after a short warning time, possibly in connection with a start lock.
- Engine forced to run at low idle speed to cool the engine, with automatic shutdown if necessary.
- Start lock

Please contact your DEUTZ-partner in case of malfunctions and spare parts inquiries. Our specially trained personnel will ensure fast, professional repairs using original DEUTZ spare parts in case of damage.

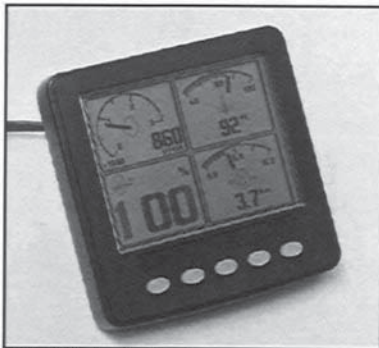

DEUTZ Electronic Display

In order to show measured values and error messages of the EMR control unit, a CAN display is optionally available, which can be integrated into the dashboard of the driver's position of working machines.

All data sent from the EMR control unit through CAN can be displayed.

- Engine speed
- Engine torque (current)
- Lubricating oil temperature
- Coolant temperature
- Suction intake air temperature
- Exhaust gas temperature
- Gear oil temperature
- Lubricating oil pressure
- Coolant pressure
- Charge air pressure
- Fuel pressure

- Gear oil pressure
- Battery voltage
- Accelerator position
- Fuel consumption

Error messages are displayed in clear text and acoustically; the error memory of the control unit can be read out.

For a detailed description, refer to the operating instructions enclosed with the DEUTZ Electronic Display.

8

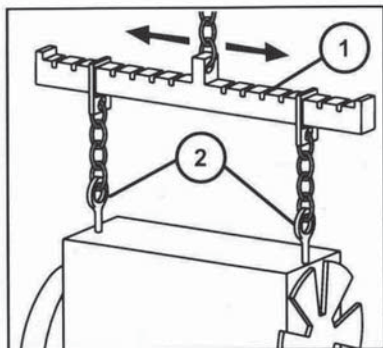

Suspension equipment

- Always use proper suspension equipment when transporting the engine.
- The suspension device (1) must be adjustable for the engine's centre of gravity.
- After transportation and before commissioning of engine: remove attachment eyes (2).

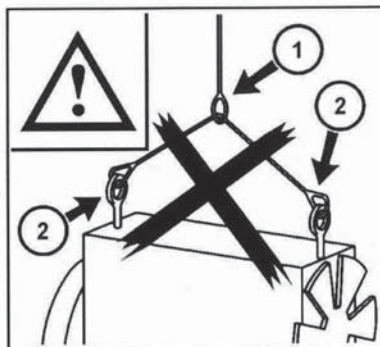

Danger to life!

The engine may tip over or fall down if suspended incorrectly!

- The fastening attachment cannot be fixed securely above the centre of gravity (1).
- The fastening attachment can slip, the engine swings backwards and forwards (1).
- Too short a fastening attachment causes bending torques in the transport device (2) and can damage it.

General

Engines contain the following types of corrosion protection:

- Interior corrosion protection
- Exterior corrosion protection



Your DEUTZ partner has the right corrosion protection agent for your needs.

The following measures for corrosion protection after taking the engine out of operation meet the requirements for 12 months corrosion protection.

The following corrosion protection work may only be carried out by persons familiar with it and instructed in the potential dangers.

If these measures are deviated from by exposing the corrosion-protected engines or parts to unfavourable conditions (installation outdoors or storage in damp, badly aired places) or damage to the corrosion protection layer, a shorter corrosion protection duration is to be expected.

The engine corrosion protection should be checked about every 3 months by opening the covers. If corrosion is detected, the corrosion protection should be renewed.

At the end of the corrosion protection work the crank drive may no longer be turned so that the corrosion protection agent in the bearings, bearing liners and cylinder liners is not scraped off.

Before operating a corrosion protected engine, the corrosion protection must be removed.

Interior corrosion protection

- Interior corrosion protection is always provided

by wetting of the walls with the implemented corrosion protection agent in a corrosion protection run of the engine.

- The corrosion protection run can be performed once to protect the different systems.

Fuel system



Close the fuel/tank/supply line to the engine so that the system is protected against dirt and dust. Protect the electronics against moisture and corrosion.

- Fill the fuel tank with a mixture of:
 - 90 % distilled fuel
 - 10 % corrosion protection oil SAE 20W-20
- Perform a corrosion protection run with no load for at least 5 minutes.

Lubricating oil system

- Drain lubricating oil from warm engine.
- Thoroughly clean lube oil tray, cylinder head with rocker arms, valves, valve springs with diesel fuel or cleaning agent.
- Fill the engine with corrosion protection oil SAE 20W-20 up to the MAX mark and perform a corrosion protection run for at least 5 minutes so that all the components of the lubricating oil system are wetted or wet all accessible parts with corrosion protection oil and pump corrosion protection oil through the engine with a separate pump until all bearings and bearing liners are wetted.

Air compressor

- If a compressor is installed, a corrosion protection agent must be sprayed into the compressor

suction system after shutting down the engine until it emerges visibly from the pressure nozzle.

Cooling system

- Depending on the series the engines are equipped with cooling air, cooling oil or cooling fluid system (cooling water with cooling system protection agent).
- Cooling air system, see the Exterior corrosion protection section.
- In engines of the oil-cooled series the circulating lubricating oil serves simultaneously for cooling. The cooling chambers are protected automatically against corrosion with the lube oil system.

D/TD/TC/D 2011 w

- If a coolant with corrosion protection properties is poured into liquid-cooled engines, no further action is necessary after draining.
- If not, the coolant must be drained and, to ensure the formation of a covering layer on the inside surfaces of the cooling system, a corrosion protection run performed with a mixture of:
 - 95 % treated water
 - 5 % corrosion protection agent
- The duration of the corrosion protection run and the concentration of the corrosion protection agent are specified by the manufacturer of the corrosion protection agent.
- Then drain the coolant.

Air intake pipes

- After the corrosion protection run, remove the cylinder head cover and deinstall injectors. The respective piston must be set to LT.
- The accessible part of the cylinder liner should be coated with corrosion protection oil with a spray lance through the opening.
- Spray corrosion protection oil SAE 20W-20 into the suction air intake line.

Exterior corrosion protection

- The engine must be cleaned thoroughly with a cleaning agent before exterior corrosion protection. Any signs of corrosion and damage to the paintwork must be removed.

Cooling air system in air-cooled engines

- The air guidance compartment of the engines is unpainted and must be sprayed with a corrosion protection agent.

Bare exterior surfaces and parts

- Coat or spray all bare exterior parts and surfaces (e.g. flywheel, flange faces) with corrosion protection agent.

Rubber parts

- Rubber parts (e.g. mufflers) which are not painted over must be rubbed down with talcum powder.

Belt drive

- Remove V-belts and V-rib belts and store packed.
- Spray V-belt pulleys and tension rollers with corrosion protection agent.

- Toothed belts for engine control may not be removed.

Engine openings

- All engine openings must be fitted with air-tight, water-tight covers to delay the vapourisation process of the corrosion protection agents.
- With installed air compressor, the suction and pressure connection must be sealed by a cap.
- Air should be excluded to avoid ventilation of the engine (chimney effect) for the suction from an air supply pipe.

Storage and packaging

- After being protected against corrosion, the engine must be stored in a dry, ventilated hall and suitably covered.
- The cover must be placed loosely over the engine so that the air can circulate around it to prevent condensation from forming. Use a desiccant if necessary.

Removal of corrosion protection

- The corrosion protection must be removed from the corrosion protected engine before starting.
- The packaging and all covers over the closed openings must be removed.
- Any corrosion deposits and paint damage should be remedied.

Fuel system

- If there is a mixture of diesel fuel/corrosion protection oil in the fuel tank, drain it.
- Connect fuel/tank/supply line to the engine. Pay attention to cleanliness.
 - Fill the fuel tank and fuel system with the proper

fuel.

Lubricating oil system

- Unscrew the lube oil drain screw, drain oil.
- Fill the engine with lubricating oil via the lubricating oil filler neck.

Coolant system**D/TD/TCD 2011 w**

- If the implemented corrosion protection agent is compatible with the intended cooling system protection agent, this can be filled directly into the coolant system as specified.
- If it is uncertain whether the implemented corrosion protection agent is compatible with the cooling system protection agent, the cooling system should be purged with fresh water for about 15 minutes before filling.

Removal of exterior corrosion protection

- All areas and components coated with corrosion protection agent must be washed off with distilled fuel or a suitable cleaning agent.
- Wash out grooves of V-belt pulleys if necessary.
- Mount V-belts or V-rib belts as specified.
- Fill with coolant.

General technical data

Engine type	Dimension	D 2011 L02 i	D 2011 L03 i	D 2011 L04 i	TD 2011 L04 i
Working principle		Four-stroke diesel engine			
Charging		Suction motor			Exhaust gas turbo-charger
Type of cooling		oil-cooled (integrated cooler)			
Cylinder arrangement		in series			
No. of cylinders		2	3	4	4
Bore/stroke	[mm]	94/112		96/125	
Total displacement	[cm ³]	1554	2331	3619	
Combustion process		Direct injection			
Injection system		Pump-pipe-nozzle			
Exhaust gas recirculation		without	without	external	internal
Valves per cylinder		2	2	2	2
Valve clearance: Inlet/outlet	[mm]	0,3 ^{+0,1} / 0,5 ^{+0,1}			
Firing order of the engine		1-2	1-2-3	1-3-4-2	
Direction of rotation looking onto the flywheel		left			
Engine power rating according to ISO 3046	[kW]	see engine rating plate			
Speed (nominal revolutions)	[rpm]	see engine rating plate			
Injection timing	[°BTDC]	see engine rating plate			
Lubricating oil filling volume (without/with filter)	≈ [l]	6/6,5*	5,5/6*	11,3/11,8*	
Lube oil temperature in the lube oil tray, maximum	[°C]	130			
Lubricating oil pressure minimum (low idle, engine warm)	[kPa/bar]	150/1,5			
V-belt tension		Pre-tensioning/Re-tensioning			
V-belt AVX 10	[N]	450±50/300±20			
Weight without cooling system according to DIN 70020-A	≈ [kg]	175	217	261	258

Engine type	Dimension	D 2011 L02 o	D 2011 L03 o
Working principle		Four-stroke diesel engine	
Charging		Suction motor	
Type of cooling		oil-cooled	
Cylinder arrangement		in series	
No. of cylinders		2	3
Bore/stroke	[mm]	94/112	
Total displacement	[cm ³]	1554	2331
Combustion process		Direct injection	
Injection system		Pump-pipe-nozzle	
Exhaust gas recirculation		without	without
Valves per cylinder		2	2
Valve clearance: Inlet/outlet	[mm]	0,3 ^{+0,1} / 0,5 ^{+0,1}	
Firing order of the engine		1-2	1-2-3
Direction of rotation looking onto the flywheel		left	
Engine power rating according to ISO 3046	[kW]	see engine rating plate	
Speed (nominal revolutions)	[rpm]	see engine rating plate	
Injection timing	[°BTDC]	see engine rating plate	
Lubricating oil filling volume (without/with filter)	≈ [l]	6/6,5*	5,5/6,0*
Lube oil temperature in the lube oil tray, maximum	[°C]	130	
Lubricating oil pressure minimum (low idle, engine warm)	[kPa/bar]	150/1,5	
V-belt tension		Pre-tensioning/Re-tensioning	
V-belt AVX 10	[N]	450±50/300±20	
Weight without cooling system according to DIN 70020-A	≈ [kg]	169	210

Engine type	Dimension	D 2011 L04 o	TD 2011 L04 o
Working principle		Four-stroke diesel engine	
Charging		Suction motor	Exhaust gas turbocharger
Type of cooling		oil-cooled	
Cylinder arrangement		in series	
No. of cylinders		4	4
Bore/stroke	[mm]	96/125	
Total displacement	[cm ³]	3619	
Combustion process		Direct injection	
Injection system		Pump-pipe-nozzle	
Exhaust gas recirculation		external	internal
Valves per cylinder		2	2
Valve clearance: Inlet/outlet	[mm]	0,3 ^{+0,1} / 0,5 ^{+0,1}	
Firing order of the engine		1-3-4-2	
Direction of rotation looking onto the flywheel		left	
Engine power rating according to ISO 3046	[kW]	see engine rating plate	
Speed (nominal revolutions)	[rpm]	see engine rating plate	
Injection timing	[°BTDC]	see engine rating plate	
Lubricating oil filling volume (without/with filter)	≈ [l]	10*/10,5*	
Lube oil temperature in the lube oil tray, maximum	[°C]	130	
Lubricating oil pressure minimum (low idle, engine warm)	[kPa/bar]	150/1,5	
V-belt tension		Pre-tensioning/Re-tensioning	
V-belt AVX 10	[N]	450±50/300±20	
Weight without cooling system according to DIN 70020-A	≈ [kg]	253	255

Engine type	Dimension	D 2011 L04 w	TD 2011 L04 w	TCD 2011 L04 w
Working principle		Four-stroke diesel engine		
Charging		Suction motor	Exhaust gas turbocharger	Turbocharger with charge air cooling
Type of cooling		water-cooled		
Cylinder arrangement		in series		
No. of cylinders		4	4	4
Bore/stroke	[mm]	96/125		
Total displacement	[cm ³]	3619		
Combustion process		Direct injection		
Injection system		Pump-pipe-nozzle		
Exhaust gas recirculation		external	internal	internal
Valves per cylinder		2	2	2
Valve clearance: Inlet/outlet	[mm]	0,3 ^{+0,1} / 0,5 ^{+0,1}		
Firing order of the engine		1-3-4-2		
Direction of rotation looking onto the flywheel		left		
Engine power rating according to ISO 3046	[kW]	see engine rating plate		
Speed (nominal revolutions)	[rpm]	see engine rating plate		
Injection timing	[°BTDC]	see engine rating plate		
Coolant volume (only engine content without cooler / hoses and pipes)	≈ [l]	2,9		
Permissible continuous coolant temperature	[°C]	max. 110		
Temperature difference between coolant inlet/outlet	[°C]	4 - 6		
Start of thermostat opening	[°C]	88		
Thermostat fully open	[°C]	92		
Lubricating oil filling volume (without/with filter)	≈ [l]	10,0*/10,5*		
Lube oil temperature in the lube oil tray, maximum	[°C]	130		

Engine type	Dimension	D 2011 L04 w	TD 2011 L04 w	TCD 2011 L04 w
Lubricating oil pressure minimum (low idle, engine warm)	[kPa/bar]	150/1,5		
Charge air temperature outlet at rated power	[°C]			50
V-belt tension		Pre-tensioning/Re-tensioning		
V-belt AVX 10	[N]	450±50/300±20		
Weight without cooling system according to DIN 70020-A	≈ [kg]	266	268	
*specified lubricating oil filling volumes apply for standard versions. In engines which deviate from the standard, for example different lubricating oil pans/dipstick variants and/or special inclined versions, the lubricating oil volume may vary. The lubricating oil dipstick mark is always decisive.				

Tool ordering

The special tools described in this chapter can be ordered from:

Please contact your DEUTZ partner

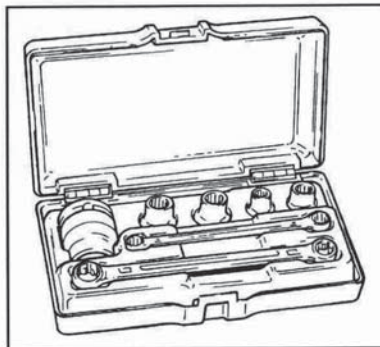

Torx tool

Order number:

8189

The Torx screw system is used in engines in this series among other things. This system was introduced for a number of reasons:

- Excellent accessibility
- High force transmission when loosening and tightening
- Slipping or breaking of the key and risk of injury are practically excluded.

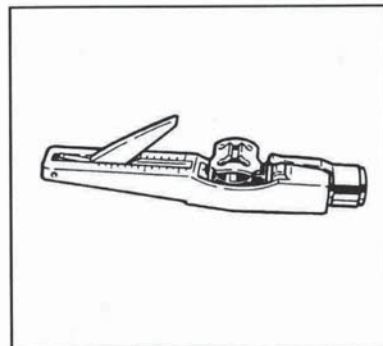

V-belt tension measuring instrument

Order number:

8115

Measuring instrument for checking the specified V-belt tensions.

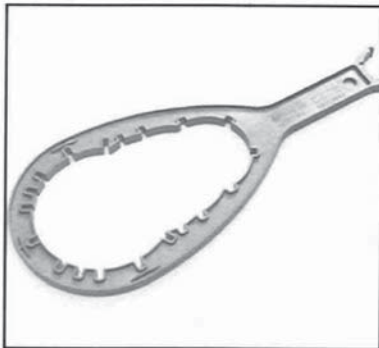

Special tools for removing the water collection vessel.

Order number:

8192

On Racor filters, only loosen the water collection vessel with a special tool.

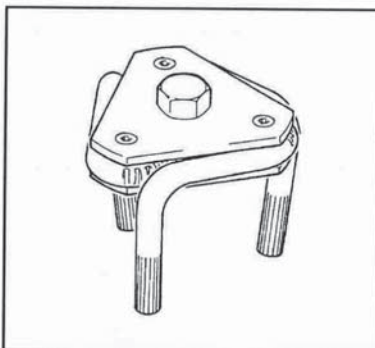

Special wrench

Order number:

170050

For loosening changeable filters.

DEUTZ Oil



DEUTZ Oil DQC II-05

ACEA E5-02 / E3-96 / B3-04
API CG-4

TLS-15W40D (DQC II-05)	
5 L	0101 6331
20 L	0101 6332
209 L	0101 6333



DEUTZ Oil DQC III-05

ACEA E7-04 / E5-02 / E3-96 / B4-04 / A3-04
API CI-4 / SL GLOBAL DHD-1

TLX-10W40FE (DQC III-05)	
5 L	0101 6335
20 L	0101 6336
209 L	0101 6337



DEUTZ Oil DQC IV-05 (Synthetic)

ACEA E7-04 / E5-02 / E4-99

DEUTZ Oil DQC IV-5W30 (DQC IV-05)	
5 L	-
20 L	0101 7849
209 L	0101 7850



The engine company.

DEUTZ AG
Supporthouse Information Systems
Ottostraße 1
51149 Köln
Germany
Phone: +49 (0) 221-822-0
Fax: +49 (0) 221-822-5850
E-Mail: info@deutz.com
www.deutz.com

Printed in Germany
© 02/2008
All rights reserved
Order number:
0312 3547 en



3124206



An Oshkosh Corporation Company

Corporate Office

JLG Industries, Inc.

1 JLG Drive

McConnellsburg, PA 17233-9533 USA

☎ (717) 485-5161 (Corporate)

☎ (877) 554-5438 (Customer Support)

☎ (717) 485-6417

Visit our website for JLG Worldwide Locations

www.jlg.com