



An Oshkosh Corporation Company

Service & Maintenance Manual

Models **3394RT** **4394RT**

S/N 0200191606 to Present

including S/N's:

0200186972,

0200187002,

0200187013

3121249

May 16, 2014

ANSI

CE



An Oshkosh Corporation Company

SECTION A. INTRODUCTION - MAINTENANCE SAFETY PRECAUTIONS

A. GENERAL

This section contains the general safety precautions which must be observed during maintenance of the aerial platform. It is of utmost importance that maintenance personnel pay strict attention to these warnings and precautions to avoid possible injury to themselves or others, or damage to the equipment. A maintenance program must be followed to ensure that the machine is safe to operate.

⚠ WARNING

MODIFICATION OF THE MACHINE WITHOUT APPROVAL BY JLG INDUSTRIES INC., IS A SAFETY VIOLATION.

The specific precautions to be observed during maintenance are inserted at the appropriate point in the manual. These precautions are, for the most part, those that apply when servicing hydraulic and larger machine component parts.

Your safety, and that of others, is the first consideration when engaging in the maintenance of equipment. Always be conscious of weight. Never attempt to move heavy parts without the aid of a mechanical device. Do not allow heavy objects to rest in an unstable position. When raising a portion of the equipment, ensure that adequate support is provided.

⚠ WARNING

SINCE THE MACHINE MANUFACTURER HAS NO DIRECT CONTROL OVER THE FIELD INSPECTION AND MAINTENANCE, SAFETY IN THIS AREA RESPONSIBILITY OF THE OWNER/OPERATOR.

B. HYDRAULIC SYSTEM SAFETY

It should be noted that the machines hydraulic systems operate at extremely high potentially dangerous pressures. Every effort should be made to relieve any system pressure prior to disconnecting or removing any portion of the system.

Relieve system pressure by cycling the applicable control several times with the engine stopped and ignition on, to direct any line pressure back into the

reservoir. Pressure feed lines to system components can then be disconnected with minimal fluid loss.

C. MAINTENANCE

⚠ WARNING

FAILURE TO COMPLY WITH SAFETY PRECAUTIONS LISTED IN THIS SECTION MAY RESULT IN MACHINE DAMAGE, PERSONNEL INJURY OR DEATH AND IS A SAFETY VIOLATION.

- No smoking is mandatory. never refuel during electrical storms. ensure that fuel cap is closed and secure at all other times.
- Remove all rings, watches and jewelry when performing any maintenance.
- Do not wear long hair unrestrained, or loose-fitting clothing and neckties which are apt to become caught on or entangled in equipment.
- Observe and obey all warnings and cautions on machine and in service manual.
- Keep oil, grease, water, etc. wiped from standing surfaces and hand holds.
- Use caution when checking a hot, pressurized coolant system.
- Never work under an elevated sizzor until platform has been safely restrained from any movement by blocking or overhead sling, or boom safety prop has been engaged.
- Before making adjustments, lubricating or performing any other maintenance, shut off all power controls.
- Battery should always be disconnected during replacement of electrical components.
- Keep all support equipment and attachments stowed in their proper place.
- Use only approved, nonflammable cleaning solvents.

REVISION LOG

Original Issue - October 6, 2008

Revised - November 3, 2008

Revised - November 30, 2010

Revised - July 19, 2012

Revised - May 16, 2013

Revised - May 16, 2014

TABLE OF CONTENTS

SUBJECT - SECTION, PARAGRAPH	PAGE NO.
SECTION A - INTRODUCTION - MAINTENANCE SAFETY PRECAUTIONS	
A General	A
A Hydraulic System Safety	A
A Maintenance	A
SECTION 1 - SPECIFICATIONS	
1.1 Specifications	1-1
1.2 Capacities	1-1
1.3 Engines	1-1
1.4 Tires	1-2
1.5 Machine Dimensions	1-2
1.6 Pressure Settings	1-2
1.7 Serial Number Locations	1-2
1.8 Sensors	1-3
1.9 Cylinder Specifications	1-3
1.10 Major Component Weights	1-3
1.11 Critical Stability Weights	1-4
1.12 Lubrication Specifications	1-4
1.13 Operator Maintenance	1-5
1.14 Torque Charts	1-10
SECTION 2 - GENERAL	
2.1 Machine Preparation, Inspection, and Maintenance	2-1
2.2 Service and Guidelines	2-2
2.3 Lubrication and Information	2-4
2.4 Cylinder Drift Test	2-5
2.5 Pins and Composite Bearing Repair Guidelines	2-5
2.6 Preventive Maintenance and Inspection Schedule	2-6
SECTION 3 - CHASSIS, PLATFORM & SCISSOR ARMS	
3.1 Operating Characteristics	3-1
3.2 Tires, Wheels & Drive Assembly	3-1
3.3 Integrated Torque/drive hub	3-4
3.4 Front Axle	3-26
3.5 Leveling Jacks (If Equipped)	3-29
3.6 Platform	3-31
3.7 Scissor Arms	3-35
3.8 Side Compartment Covers	3-37
3.9 Ground Control Station	3-38
3.10 Fuel Tank	3-39
3.11 Hydraulic Tank	3-40
3.12 Battery	3-41
3.13 Dual Fuel/LPG System	3-42
3.14 Deutz Engine	3-43
3.15 GM Engine	3-64
3.16 GM Engine Dual Fuel System	3-74
3.17 GM Engine Fuel System Repair	3-78
3.18 GM Engine LPG Fuel System Diagnosis	3-84
SECTION 4 - HYDRAULICS	
4.1 Cylinders - Theory of Operation	4-1
4.2 Valves - Theory of Operation	4-1
4.3 Cylinder Checking Procedure	4-1

TABLE OF CONTENTS

4.4	Cylinder Repair	4-3
4.5	Drive Pump Start-up Procedure	4-8
4.6	Hydraulic Component Start-Up Procedures & Recommendations	4-9
4.7	Hydraulic Gear Pump	4-10
4.8	Valves	4-13
4.9	Gear Pump	4-21
4.10	Axial HI 45 Pump	4-22
4.11	Charge Pump Filter	4-31
4.12	Auxiliary Pump Motor	4-32
4.13	Cylinder Assemblies	4-33
SECTION 5 - JLG CONTROL SYSTEM		
5.1	Hand Held Analyzer	5-1
5.2	Calibrations	5-6
5.3	Flash Codes and Descriptions	5-9
SECTION 6 - GENERAL ELECTRICAL INFORMATION & SCHEMATICS		
6.1	General	6-1
6.2	Multimeter Basics	6-1
6.3	Applying Silicone Dielectric Compound To Amp Connectors	6-5
6.4	Working With Deutsch Connectors	6-10
6.5	Switches	6-12
6.6	Schematics	6-14

LIST OF FIGURES

FIGURE NO.	TITLE	PAGE NO.
1-1.	Serial Number Location	1-2
1-2.	Operator Maintenance and Lubrication Diagram	1-5
1-3.	Filter Lock Assembly	1-9
1-4.	Torque Chart (SAE Fasteners - Sheet 1 of 3)	1-10
1-5.	Torque Chart (SAE Fasteners - Sheet 2 of 3)	1-11
1-6.	Torque Chart (SAE Fasteners - Sheet 3 of 3)	1-12
1-7.	Torque Chart (METRIC Fasteners - Sheet 1 of 3)	1-13
1-8.	Torque Chart (METRIC Fasteners - Sheet 2 of 3)	1-14
1-9.	Torque Chart (METRIC Fasteners - Sheet 3 of 3)	1-15
2-1.	Engine Operating Temperature Specifications - Deutz	2-8
2-2.	Engine Operating Temperature Specifications - GM	2-9
3-1.	Drive Assembly	3-3
3-2.	Integrated Torque/Drive Hub	3-4
3-3.	Drive Motor/Hub Assembly	3-5
3-4.	Drive Hub Assembly	3-14
3-5.	Steering Assembly	3-26
3-6.	Axle Assembly	3-27
3-7.	Axle Lockout Cylinder	3-28
3-8.	Leveling Jack Cylinder Removal	3-29
3-9.	Leveling Jacks Assembly	3-30
3-10.	Platform Removal	3-31
3-11.	Deck Extension Cylinders Removal	3-32
3-12.	Platform Control Station	3-33
3-13.	Joystick Controller	3-34
3-14.	Lift Cylinder Removal	3-35
3-15.	Scissor Arms Removal	3-36
3-16.	Scissor Assembly Removal - Chassis Connection	3-36
3-17.	Ground Control Station Removal	3-38
3-18.	Ground Control Station	3-38
3-19.	Fuel Tank Removal	3-39
3-20.	Hydraulic Tank Removal	3-40
3-21.	Battery Removal	3-41
3-22.	Engine Tray Swing	3-43
3-23.	EMR 2 Engine Side Equipment	3-44
3-24.	Deutz EMR 2 Troubleshooting Flow Chart	3-45
3-25.	Deutz EMR 2 Vehicle Side Connection Diagram	3-46
3-26.	Deutz EMR 2 Engine Side Connection Diagram - Sheet 1 of 2	3-47
3-27.	Deutz EMR 2 Engine Side Connection Diagram - Sheet 2 of 2	3-48
3-28.	EMR 2 Engine Plug Pin Identification	3-49
3-29.	EMR 2 Vehicle Plug Pin Identification	3-50
3-30.	EMR2 Fault Codes - Sheet 1 of 5	3-51
3-31.	EMR2 Fault Codes - Sheet 2 of 5	3-52
3-32.	EMR2 Fault Codes - Sheet 3 of 5	3-53
3-33.	EMR2 Fault Codes - Sheet 4 of 5	3-54
3-34.	EMR2 Fault Codes - Sheet 5 of 5	3-55
3-35.	Generator (Deutz Engine)	3-56
3-36.	Exhaust System (Deutz Engine)	3-57
3-37.	Air Cleaner System (Deutz Engine)	3-58
3-38.	Relays (Deutz Engine)	3-59
3-39.	Pump Assemblies (Deutz Engine)	3-60
3-40.	Pump Coupling (Deutz Engine)	3-61
3-41.	Engine Removal (Deutz Engine)	3-62
3-42.	Radiator (Deutz Engine)	3-63
3-43.	Engine Oil Dip Stick	3-65

TABLE OF CONTENTS

3-44.	Engine Tray Swing	3-65
3-45.	Generator (GM Engine)	3-66
3-46.	GM Exhaust System (GM Engine)	3-67
3-47.	Air Cleaner System (GM Engine)	3-68
3-48.	Radiator (GM Engine)	3-69
3-49.	Fuel Components (GM Engine)	3-70
3-50.	Pump Assemblies (GM Engine)	3-71
3-51.	Pump Coupling (GM Engine)	3-72
3-52.	Engine Removal (GM Engine)	3-73
3-53.	Electric Fuel Lock Off	3-74
3-54.	EPR Assembly	3-74
3-55.	Low Pressure Regulators	3-75
3-56.	Air Fuel Mixer	3-75
3-57.	ETC throttle control device	3-76
3-58.	LPG Engine Control Unit (ECM)	3-76
3-59.	ECM Assembly	3-76
3-60.	Heated Exhaust Gas Oxygen Sensor (HEGO)	3-77
3-61.	Gasoline Fuel Pressure and Temperature Manifold Assembly	3-77
3-62.	Filter Lock Assembly	3-79
3-63.	EPR Assembly	3-79
3-64.	Pressure Regulator Section	3-80
3-65.	(TMAP) Sensor & Electronic Throttle Control (ETC)	3-81
3-66.	Mixer Assembly	3-82
3-67.	EPR Assembly	3-84
4-1.	Lift Cylinder Holding Valve and Fitting Removal	4-3
4-2.	Cylinder Barrel Support	4-3
4-3.	Lift Cylinder Cap Screw Removal	4-3
4-4.	Cylinder Rod Support	4-4
4-5.	Tapered Bushing Removal	4-4
4-6.	Bushing Installation	4-5
4-7.	Rod Seal Installation	4-5
4-8.	Poly-Pak Piston Seal Installation	4-5
4-9.	Wiper Seal Installation	4-6
4-10.	Installation of Head Seal Kit	4-6
4-11.	Piston Seal Kit Installation	4-6
4-12.	Tapered Bushing Installation	4-7
4-13.	Seating the Tapered Bearing	4-7
4-14.	Rod Assembly Installation	4-7
4-15.	Hydraulic Compartment	4-13
4-16.	Main Valve Block	4-14
4-17.	Main Valve Schematic	4-15
4-18.	Flow Divider Valve	4-16
4-19.	Leveling Jacks Directional Valve	4-17
4-20.	Powerdeck Valve (Single)	4-18
4-21.	Powerdeck Valve (Double)	4-18
4-22.	Leveling Jack Valves	4-19
4-23.	Gear Pump	4-21
4-24.	Axial HI 45 Pump	4-22
4-25.	Axial HI 45 Pump - Cross Section View	4-23
4-26.	Charge Pump Filter	4-31
4-27.	Auxiliary Pump Motor	4-32
4-28.	Steer Cylinder	4-33
4-29.	Lift Cylinder	4-34
4-30.	Lift Cylinder Valve Cartridge Torque Values	4-35
4-31.	Oscillating Axle Cylinder	4-36
4-32.	Leveling Jack Cylinder	4-37
4-33.	Leveling Jack Torques	4-38
4-34.	Deck Extension Cylinder	4-39

4-35.	Oscillating Axle Cylinder Bleeding	4-40
5-1.	Hand Held Analyzer	5-1
5-2.	Analyzer Connection	5-1
5-3.	Limit Switch Location	5-6
5-4.	Tilt Sensor Location	5-8
5-5.	Tilt Sensor Removal	5-8
5-6.	Analyzer Flow Chart - SW P1.X - Sheet 1 of 3	5-16
5-7.	Analyzer Flow Chart - SW P1.X - Sheet 2 of 3	5-17
5-8.	Analyzer Flow Chart - SW P1.X - Sheet 3 of 3	5-18
6-1.	Voltage Measurement (DC)	6-2
6-2.	Resistance Measurement	6-2
6-3.	Continuity Measurement	6-3
6-4.	Current Measurement (DC)	6-3
6-5.	AMP Connector	6-5
6-6.	Connector Assembly (1 of 4)	6-6
6-7.	Connector Assembly (2 of 4)	6-6
6-8.	Connector Assembly (3 of 4)	6-7
6-9.	Connector Assembly (4 of 4)	6-7
6-10.	Connector Disassembly	6-8
6-11.	Connector Installation	6-9
6-12.	DT/DTP Contact Installation	6-10
6-13.	DT/DTP Contact Removal	6-10
6-14.	HD/HDP Contact Installation	6-10
6-15.	HD/HDP Locking Contacts Into Position	6-11
6-16.	HD/HDP Contact Removal	6-11
6-17.	HD/HDP Unlocking Contacts	6-11
6-18.	Electrical Schematic - Deutz - Sheet 1 of 3	6-14
6-19.	Electrical Schematic - Deutz - Sheet 2 of 3	6-15
6-20.	Electrical Schematic - Deutz - Sheet 3 of 3	6-16
6-21.	Electrical Schematic - GM - Sheet 1 of 5	6-18
6-22.	Electrical Schematic - GM - Sheet 2 of 5	6-19
6-23.	Electrical Schematic - GM - Sheet 3 of 5	6-20
6-24.	Electrical Schematic - GM - Sheet 4 of 5	6-22
6-25.	Electrical Schematic - GM - Sheet 5 of 5	6-23
6-26.	Hydraulic Schematic - Sheet 1 of 2	6-24
6-27.	Hydraulic Schematic - Sheet 2 of 2	6-25
6-28.	Hydraulic Diagram	6-26
6-29.	Hydraulic Diagram (Powerdeck - Single)	6-27
6-30.	Hydraulic Diagram (Powerdeck - Dual)	6-28
6-31.	Hydraulic Diagram (Powerdeck - Mega)	6-29
6-32.	Hydraulic Diagram (Leveling Jacks)	6-30
6-33.	Electrical Components Installation - Sheet 1 of 2	6-32
6-34.	Electrical Components Installation - Sheet 2 of 2	6-33

TABLE OF CONTENTS

LIST OF TABLES

TABLE NO.	TITLE	PAGE NO.
1-1	Operating Specifications	1-1
1-2	Capacities	1-1
1-3	Deutz F3M2011 Specifications	1-1
1-4	GM 3.0L Specifications	1-1
1-5	Tire Specifications	1-2
1-6	Main Control Valve Relief Settings	1-2
1-7	High Drive Cut-Out Height	1-3
1-8	Tilt Sensor Indicators	1-3
1-9	Cylinder Specifications	1-3
1-10	Major Component Weights	1-3
1-11	Critical Stability Weights	1-4
1-12	Hydraulic Oil	1-4
1-13	Mobil DTE 13M Specs	1-4
1-14	Mobil 424 Specs	1-4
2-1	Inspection and Maintenance	2-2
2-2	Cylinder Drift	2-5
2-3	Preventive Maintenance and Safety Inspection	2-7
3-1	Wheel Torque Chart	3-2
3-2	Torque/Drive Hub Specs	3-4
3-3	Gearbox Maintenance Schedule	3-6
3-4	Joystick Specifications	3-34
3-5	Joystick Plug Loading Chart	3-34
3-6	Generator Specifications	3-56
3-7	Generator Specifications	3-66
3-8	LPF Fuel System Diagnosis	3-85
3-9	Symptom Diagnosis	3-88
3-10	DTC to SPN/FMI Cross Reference Chart	3-96
4-1	Cylinder Piston Nut Torque Specifications	4-8
4-2	Holding Valve Torque Specifications	4-8
4-3	Main Valve Torque Specs	4-15
4-4	Porting Specs	4-15
4-5	Leveling Jacks Directional Valve Torque Specs	4-17
4-6	Powerdeck Valve Torque Specs	4-18
4-7	Leveling Jack Valves Torque Specs	4-19
4-8	Gear Pump Specs	4-21
4-9	Axial HI 45 Pump Specs	4-22
5-1	Tilt Sensor Harness	5-8
5-2	Fault Code Listing - Software P1.X	5-9
5-3	Machine Configuration Programming Information	5-19
5-4	Machine Tilt Configuration	5-20
5-5	Machine Model Adjustment	5-25

SECTION 1. SPECIFICATIONS

1.1 SPECIFICATIONS

Table 1-1. Operating Specifications

Description	3394RT	4394RT
Maximum Occupants	6	
Maximum Workload (Capacity):		
Single Extension:	2250 lbs (1020 kg)	1500 lbs (680 kg)
Dual Extension:	2000 lbs (905 kg)	1250 lbs (565 kg)
Extension Only:	500 lbs (230 kg)	500 lbs (230 kg)
Maximum Travel Grade :		
2 WD	35%	
4WD	45%	
Maximum Travel Grade :	3°	
Maximum Platform Height	33 ft (10.06m)	43 ft (13.11m)
Maximum Drive Speed 2 WD	3.0 mph (4.8 kph)	3.0 mph (4.8 kph)
Maximum Drive Speed 4WD	3.5 mph (5.6 kph)	3.5 mph (5.6 kph)
Lift Up Speed (Stowed to Full Height)	29 - 31 sec	40 - 45 sec
Lift Down Speed (Full Height to Stowed)		
Maximum Wind Speed	28 mph (12.5 m/s)	
Maximum Horizontal Manual Side Force:		
Single Extension	335 lb force (1490 N)	300 lb force (1335 N)
Dual Extension	300 lb force (1335 N)	300 lb force (1335 N)
Single Extension (CE/AUS)	90 lb force (400 N)	90 lb force (400 N)
Dual Extension (CE/AUS)	90 lb force (400 N)	90 lb force (400 N)
Maximum Tire Load	4400 lbs (1996 kg)	
Ground Bearing Pressure w/Standard tires	49 psi (3.45 kg/cm ²)	56 psi (3.94 kg/cm ²)
Leveling Jack Bearing Pressure	69 psi (4.9 kg/cm ²)	
Wheelbase	9.67 ft (2.95 m)	
Ground Clearance	12 in (30 cm)	
Maximum Hydraulic System Pressure	3000 psi (207 bar)	
Electrical System Voltage	12 Volt	
Inside Turning Radius	14.5 ft (4.39 m)	
Outside Turning Radius	20.1 ft (6.12 m)	
Gross Vehicle Weight (with One Extension) Note: Certain options or country standards increase weight.	11,910 lbs (5,402 kg)	15,300 lbs (6,940 kg)

1.2 CAPACITIES

Table 1-2. Capacities

Description	3394RT	4394RT
Fuel Tank	31.5 gal (119 L)	
Hydraulic Tank:		
Total Capacity	32.3 gal (122.3 L)	
Full Level	27.3 gal (103.3 L)	
Low Level	23.6 gal (89.3 L)	

1.3 ENGINES

Table 1-3. Deutz - D 2.9 - L4 - Engine Specifications (Tier 4 Final Engine)

Emissions	EPA - Tier 4 Final	
Fuel Type:	Diesel	
Oil Capacity	2.35 Gal. (8.9 L) w/Filter	
Coolant Capacity	0.79 Gal. (3.0 L) - Engine Only	
Engine RPM Control	Deutz Electronic - EMR4	
Low RPM Set	1200 RPM	
High RPM Set	2600 RPM	
Alternator	95 Amp, 12V, Belt Drive	
Battery	112 Amp-Hour, 950 Cold Cranking Amps, 12 VDC	
Fuel Consumption:	Low RPM	1.3 GPH (4.9 lph)
	High RPM	1.6 GPH (6.0 lph)
Horsepower	49 Hp (36.4 Kw) @ 2600 RPM	
Torque Rating	108 Ft. lb. (147 Nm) @ 1600 rpm	
Cylinder Firing Order	1-3-4-2	

Table 1-4. Deutz D2011 L03 T41-Flex Specifications (Tier 4 Flex Engine)

Fuel Type:	Diesel	
Oil Capacity	8.5 Quarts (8 L) w/Filter	
Low RPM	1200	
High RPM	2800	
Alternator	95 Amp, Belt Drive	
Battery	112 Amp-Hour, 950 Cold Cranking Amps, 12 VDC	
Fuel Consumption:	Low RPM	1.3 GPH (4.9 lph)
	High RPM	1.6 GPH (6.0 lph)
Horsepower	49 @ 2800 RPM, full load	

SECTION 1 - SPECIFICATIONS

Table 1-5. Deutz F3M2011 Specifications

Fuel	Diesel
Oil Capacity	8.5 Quarts (8 L) w/Filter
Low RPM	900
High RPM	2800
Alternator	95 Amp, Belt Drive
Battery	112 Amphour, 950 Cold Cranking Amps, 12 VDC
Fuel Consumption:	
Low RPM	1.3 GPH (4.9 lph)
High RPM	1.6 GPH (6.0 lph)
Horsepower	48 @ 2800 RPM, full load

**Table 1-6. GM 3.0L Specifications
(Tier 2 and 3 Engine)**

Fuel	Gasoline or Gasoline/LP Gas
No. of Cylinders	4
HorsePower:	
Gasoline	83 hp @ 3000 rpm
LP	75 hp @ 3000 rpm
Bore	4.0 in. (101.6 mm)
Stroke	3.6 in. (91.44 mm)
Displacement	181 cu.in. (3.0 L, 2966 cc)
Oil Capacity w/filter	
Tier 2	4.5 qts. (4.25 L)
Tier 3	5.0 qts. (4.73 L)
Minimum Oil Pressure:	
at idle	6 psi (0.4 Bar) @ 1000 rpm
at operation	18 psi (1.2 Bar) @ 2000 rpm
Compression Ratio	
Tier 2	9.2:1
Tier 3	10.5:1
Firing Order	1-3-4-2
Maximum RPM	2800

1.4 TIRES

Table 1-7. Tire Specifications

Size	Ply Rating	Inflation Pressure	Wheel Nut Torque (Dry)
IN315/55D20 Pneumatic	12	75 psi (5 bar)	170 lb-ft (230 Nm)
IN315/55D20 Foam Filled	12	Foam Fill to 75 psi (5 bar)	170 lb-ft (230 Nm)
12 x 16.5 Pneumatic (Non-Marking)	10	90 psi (6 bar)	170 lb-ft (230 Nm)
12 x 16.5 Foam Filled (Non-Marking)	10	Foam Fill to 90 psi (6 bar)	170 lb-ft (230 Nm)
33/1550 x 16.5 Pneumatic	14	90 psi (6 bar)	170 lb-ft (230 Nm)
33/1550 x 16.5 Foam Filled	14	Foam Fill to 90 psi (6 bar)	170 lb-ft (230 Nm)
33/16LLx16.1 Foam Filled - Sand	10	Foam Fill to 50 psi (3.4 bar)	170 lb-ft (230 Nm)
31 x 15.50-15 Grass Master	10	60 psi (4 bar)	170 lb-ft (230 Nm)

1.5 MACHINE DIMENSIONS

Description	3394RT	4394RT
Machine Height (rails down)	61.75 in (1.6 m)	70.4 in (1.8 m)
Machine Width	94 in (2.4 m)	
Machine Length	156 in (4 m)	

1.6 PRESSURE SETTINGS

Table 1-8. Main Control Valve Relief Settings

Description	3394RT	4394RT
Main Relief	3000 psi (207 bar)	
Steer Relief	2800 psi (193 bar)	
Lift Up Relief	2700 psi (186 bar)	

1.7 SERIAL NUMBER LOCATIONS

For machine identification, a serial number plate is affixed to the machine. The plate is located at the rear of the machine on the center of the axle. In addition, should the serial number plate be damaged or missing, the machine serial number is stamped onto the lip of the rear axle.

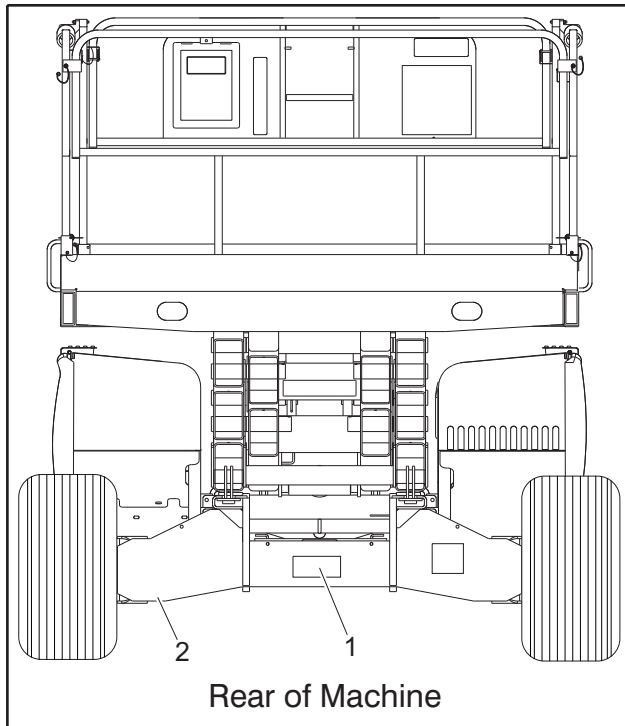

- 1. Serial Number Plate
- 2. Stamped Serial Number

Figure 1-1. Serial Number Location

1.8 SENSORS

The machine is equipped with the following limit switches:

Elevation Switch/Rotary Position Sensor - High drive speed is cut out when platform is raised above the preset heights listed in Table 1-9, High Drive Cut-Out Height.

Table 1-9. High Drive Cut-Out Height

Model	Height
3394RT	6-9 ft (1.8 - 2.7 m)
4394RT	7-10 ft (2.1 - 3 m)

Tilt Alarm - An alarm sounds and a warning light is illuminated when the machine is operated on a slope that exceeds the values in Table 1-10, Tilt Sensor Indicators. The lift and drive functions will cut out at these set heights.

NOTE: Alarm only sounds when above elevation.

If the machine is operated beyond the specified slope, with the platform completely lowered, only the warning light is illuminated.

Table 1-10. Tilt Sensor Indicators

Model	Front To Back	Side To Side
3394RT (ANSI, ANSI Export, Aus)	5° to full height	5° to 26 ft (8 m) 4° to 30 ft (9 m) 3° to 33 ft (10 m)
4394RT (ANSI, ANSI Export, Aus)	5° to full height	5° to 26 ft (8 m) 4° to 30 ft (9 m) 3° to 43 ft (13 m)
3394RT/4394RT (CSA)	3° to full height	3° to full height
3394RT/4394RT (CE)	5° to full height	3° to full height

1.9 CYLINDER SPECIFICATIONS

Table 1-11. Cylinder Specifications

Description	Bore	Stroke	Rod Dia
Lift Cylinder	4.5 in (114 mm)	83 in (2.1 mm)	3.5 in (89 mm)
Leveling Jack Cylinder	2.5 in (63.5 mm)	27 in (686 mm)	2 in (51 mm)
Lockout Cylinder (Oscillating Axle)	2.5 in (6.4 cm)	4.13 in (10.5 cm)	1.75 in (4.4 cm)
Power Deck Cylinders	15 in (38.1 mm)	48 in (1219.2 mm)	1 in (25.4 mm)
Steer Cylinder	2.5 in (63.5 mm)	9.2 in (233.7 mm)	1.75 in (44.5 mm)

1.10 MAJOR COMPONENT WEIGHTS

Table 1-12. Major Component Weights

Component	Weight
Fixed Platform	1070 lbs (485 kg)
Platform Extension	440 lbs (200 kg)
Arm Assembly- (Includes Lift Cylinder): 3394RT 4394RT	3600 lbs (1633 kg) 4550 lbs (2064 kg)
Chassis with Pneumatic Tires: 3394RT 4394RT	6790 lbs (3080 kg) 9080 lbs (4119 kg)
Chassis with Foam Filled Tires: 3394RT 4394RT	7788 lbs (3533 kg) 9086 lbs (4121 kg)

1.11 CRITICAL STABILITY WEIGHTS

⚠ WARNING

DO NOT REPLACE ITEMS CRITICAL TO STABILITY WITH ITEMS OF DIFFERENT WEIGHT OR SPECIFICATION (FOR EXAMPLE: FILLED TIRES, ENGINE) DO NOT MODIFY UNIT IN ANY WAY TO AFFECT STABILITY.

Table 1-13. Critical Stability Weights

Component	Weight
Tires	
IN315/55D20 Pneumatic	156 lbs (71 kg)
IN315/55D20 Foam Filled	156 lbs (71 kg)
12 x 16.5 Pneumatic	128 lbs (58 kg)
12 x 16.5 Foam Filled	328 lbs (149 kg)
33/1550-16.5 Pneumatic	135 lbs (61 kg)
33/1550-16.5 Foam Filled	395 lbs (179 kg)
33/16LL x 16.1 Foam Filled - Sand	426 lbs (193 kg)
31 x 15.50-15 Grass Master	125 lbs (57 kg)
Engine (Deutz)	441 lbs (200 kg)
Engine (GM)	341 lbs (155 kg)

1.12 LUBRICATION SPECIFICATIONS

Table 1-14. Hydraulic Oil

Hydraulic System Operating Temperature Range	Sae Viscosity Grade
0°F to +23°F (-18°C to -5°C)	10W
0°F to +210°F (-18°C to +100°C)	10W-20,10W-30
+50°F to +210°F (+10°C to +100°C)	20W-20

NOTE: Hydraulic oils must have anti-wear qualities at least to API Service Classification GL-3, and sufficient chemical stability for mobile hydraulic system service. JLG Industries recommends Mobilfluid 424 hydraulic oil, which has an SAE viscosity index of 152.

Table 1-15. Mobil DTE 13M Specs

ISO Viscosity Grade	#32
Specific Gravity	0.877
Pour Point, Max	-40°F (-40°C)
Flash Point, Min.	330°F (166°C)
Viscosity	
at 40°C	33cSt
at 100°C	6.6 cSt
at 100°F	169 SUS
at 210°F	48 SUS
cp at -20°F	6,200
Viscosity Index	140

Table 1-16. Mobil 424 Specs

Type	Synthetic Biodegradable
SAE Grade	10W-30
Gravity, API	29.0
Density	7.35 lb/gal (
Pour Point, Max	-46°F (-43°C)
Flash Point, Min.	442°F (228°C)
Viscosity	
at 40°C	55 cSt
at 100°C	9.3 cSt
Viscosity Index	152

1.13 OPERATOR MAINTENANCE

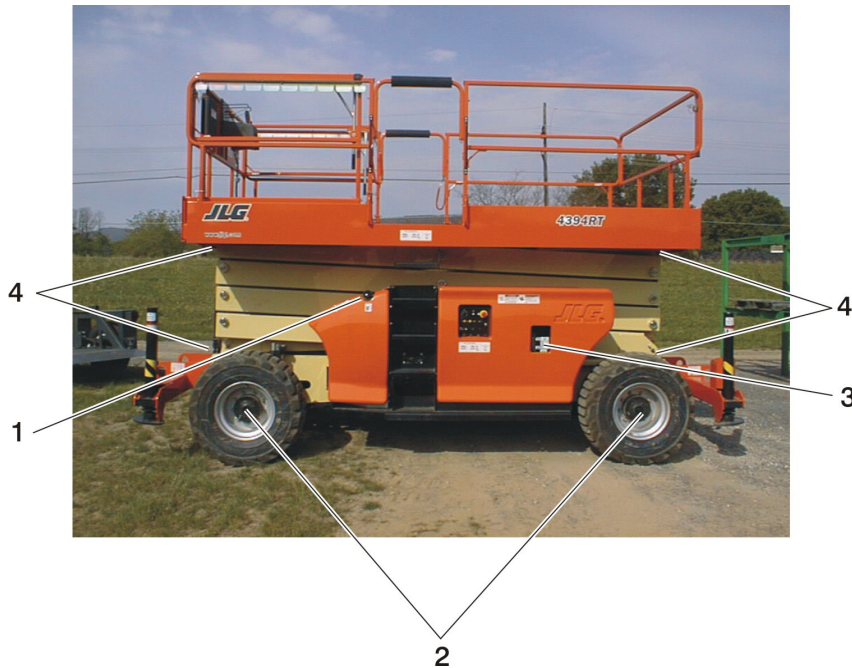

1. Fuel Tank
2. Drive Hubs
3. Hydraulic Oil Tank
4. Sliding Wear Pads
5. Oil Change w/Filter - Deutz
6. Oil Change w/Filter - GM
7. Fuel Filter - Deutz
8. Fuel Filter (Gasoline) - GM
9. Air Filter
10. Electronic Pressure Regulator (LP Only)
11. Fuel Filter (Propane) - GM

NOTE: Item #5 through #11 are on the opposite side of the machine and not shown. See following pages.

Figure 1-2. Operator Maintenance and Lubrication Diagram

⚠ WARNING

TO AVOID PERSONAL INJURY, USE SAFETY PROP FOR ALL MAINTENANCE REQUIRING PLATFORM TO BE ELEVATED.

NOTE: Be sure to lubricate like items on each side.

NOTE: Recommended lubricating intervals are based on machine operations under normal conditions. For machines used in multi-shift operations and/or exposed to hostile environments or conditions, lubrication frequencies must be increased accordingly.

Operate hydraulic functions through one complete cycle before checking hydraulic oil level in tank. Oil should be visible in ADD sight window on hydraulic tank. If oil is not visible, add oil until oil is visible in both ADD and FULL sight windows on tank. Do not overfill tank.

Any time the pump coupling is removed, coat splines of coupling with Texaco Code 1912 grease prior to assembly.

Fuel Tank



- Fuel - Diesel or Gasoline
- Capacity - 31.5 gal (119 l)

Drive Hub



- Lube Points - Fill Plugs (4)
- Lube - EPGL - Mobilube HD 80W-90 or equivalent
- Interval - Every 2 years or 1200 hours
- Total Capacity - 23.75 oz. each hub

Hydraulic Oil

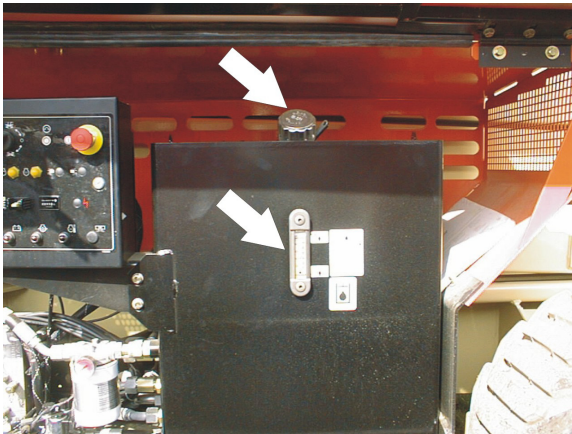

- Lube Point - Fill Cap/Fill Level
- Lube - HO
- Interval - Check oil every 10 hours of operation; change oil every 2 years or 1200 hours of operation.

1. Sliding Wear Pads

- Lube Points - 8 Sliding Wear Pads
- Lube - MPG
- Interval - Every month or 50 hours.

Engine Oil Change w/Filter - Deutz

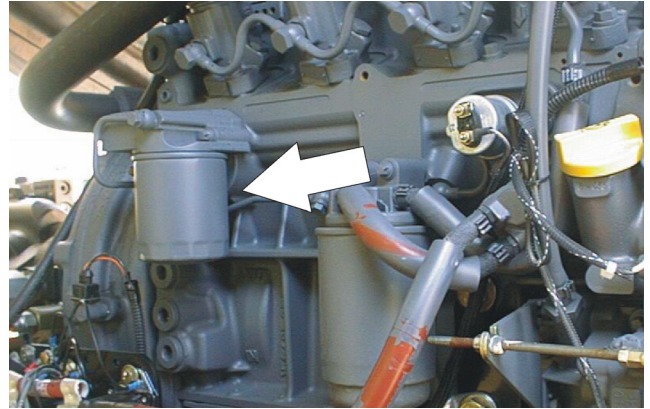

- Lube Point(s) - Fill Cap/Spin-on Element (JLG P/N 7016331)
- Capacity - 6.3 qt. (5.9 L) engine only
- Lube - EO
- Interval - Every Year or 600 hours of operation
- Comments - Check level daily/Change in accordance with engine manual.

Engine Oil Change w/Filter - Deutz D2.9 L4 - T4F

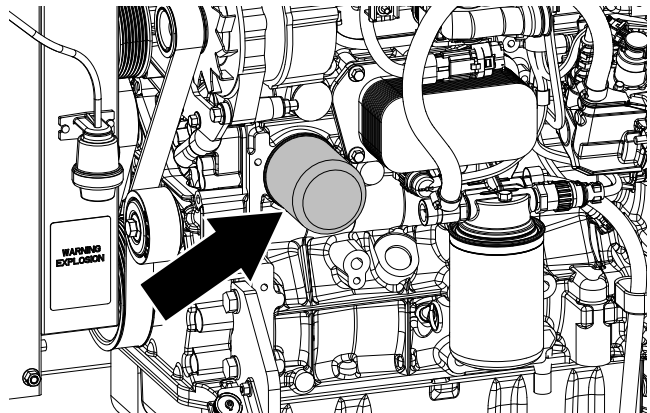

- Lube Point(s) - Fill Cap/Spin-on Element (JLG P/N 7016641)
- Capacity - 2.35 Gal. (8.9 L) engine only
- Lube - EO
- Interval - Every Year or 600 hours of operation
- Comments - Check level daily/Change in accordance with engine manual.

Oil Change w/Filter - GM

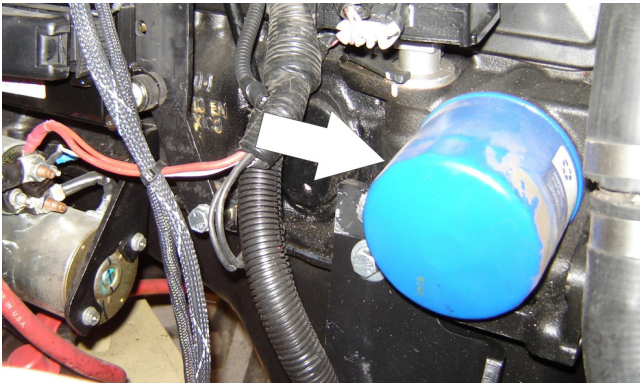

- Lube Point(s) - Fill Cap/Spin-on Element (JLG P/N 7027965)
- Capacity - 4.5 qt. (4.25 L) w/filter
- Lube - EO
- Interval - 3 Months or 150 hours of operation
- Comments - Check level daily/Change in accordance with engine manual.

Engine Fuel Filter - Deutz

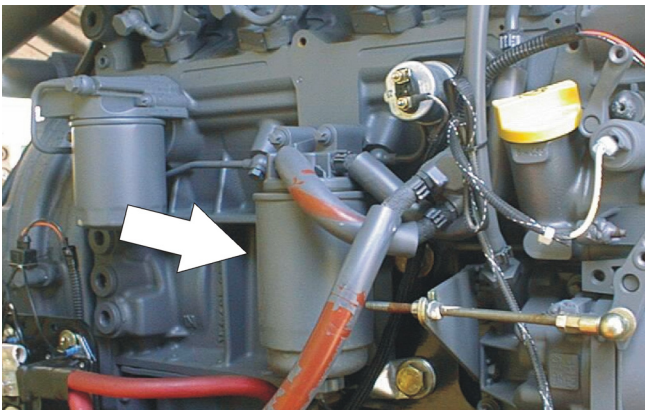

- Lube Point(s) - Replaceable Element
- Interval - Every Year or 600 hours of operation

Engine Fuel Filter - Deutz D 2.9 L4 - T4F

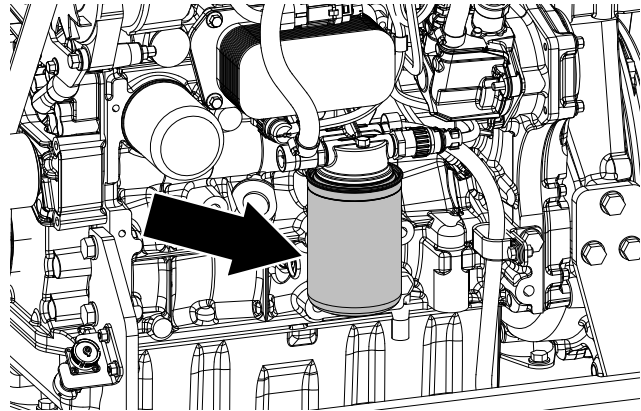

- Lube Point(s) - Replaceable Element - on engine and Pre-Filter w/pressure sensor next to fuel tank
- Interval - Every Year or 600 hours of operation

Engine Fuel Filter (Gasoline) - GM

- Lube Point(s) - Replaceable Element
- Interval - Every 6 months or 300 hours of operation

Air Filter

- Lube Point(s) - Replaceable Element
- Interval - Every 6 months or 300 hours of operation or as indicated by the condition indicator

Electronic Pressure Regulator (LP only)

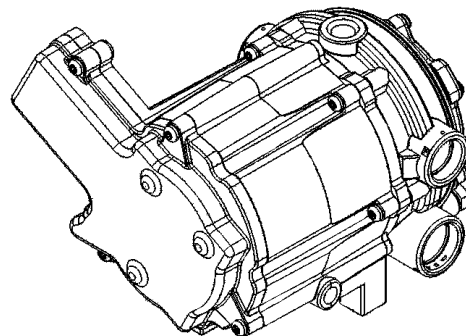

- Interval - 3 Months or 150 hours of operation
- Comments - Drain oil build up. Refer to Draining Oil Build Up From The Propane Regulator

Fuel Filter (Propane) - GM

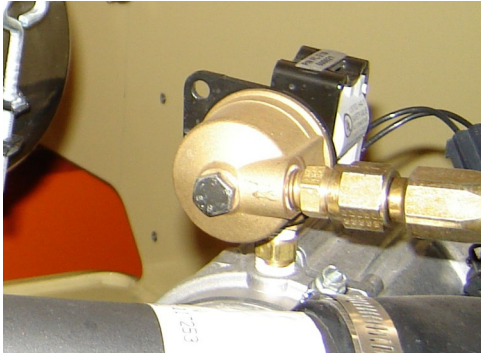

- Interval - 3 Months or 150 hours of operation
- Comments - Replace filter. Refer to Propane Fuel Filter Replacement

Draining Oil Build Up From The Propane Regulator

During the course of normal operation oils may build inside the primary and secondary chambers of the propane pressure regulator. These oils may be a result of poor fuel quality, contamination of the fuel supply chain, or regional variation in the make up of the fuel. If the build up of the oil is significant this can effect the operation of the fuel control system. Refer to Section 1.13, Operator Maintenance for maintenance intervals. More frequent draining may be required if the fuel supply has been contaminated.

NOTICE

FOR BEST RESULTS WARM THE ENGINE TO OPERATING TEMPERATURE BEFORE DRAINING. THIS WILL ALLOW THE OILS TO FLOW FREELY FROM THE REGULATOR.

1. Move the equipment to a well ventilated area. Ensure there are no external ignition sources.
2. Start the engine and bring to operating temperature.
3. With the engine running, close the manual tank valve and run the engine out of fuel.

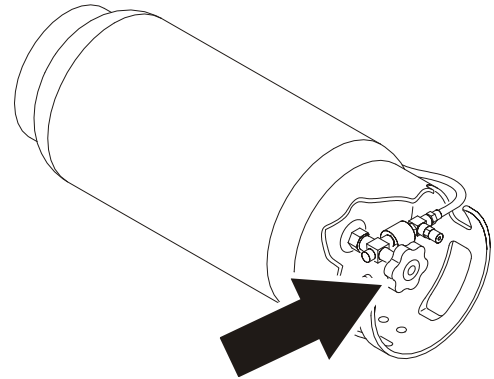

4. Push in the Emergency Switch once the engine stops.
5. Disconnect the electrical connection to the LPG fuel temperature sensor in the auxiliary fuel port of the EPR.

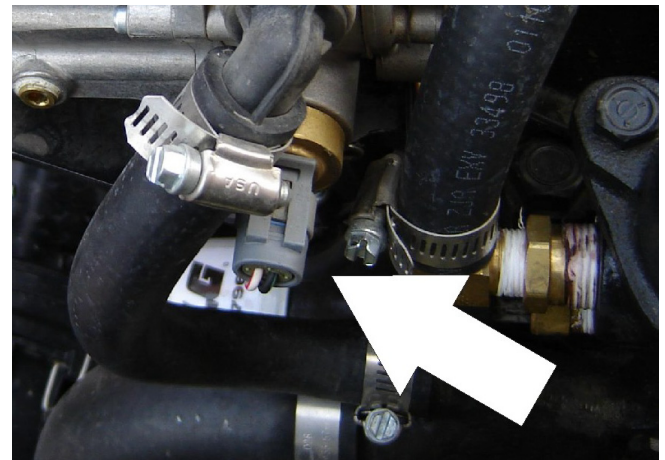

6. Remove the retainer clip for the LPG fuel temperature sensor and remove the sensor from the regulator body.

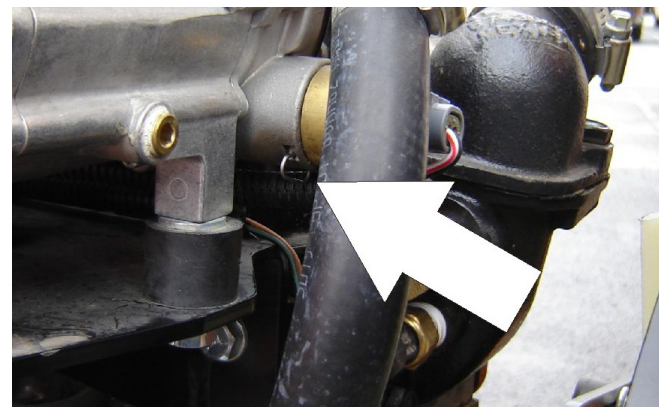

NOTE: Have a small container ready to collect oil that will drain freely from the regulator at this point.

SECTION 1 - SPECIFICATIONS

- Once all of the oil has been drained, reinstall the LPG fuel temperature sensor and reconnect the electrical connector.
- Open the fuel tank manual valve.
- Start the engine and verify all connections are secure.
- Dispose of any drained oil per local regulations in a safe and proper fashion.

Propane Fuel Filter Replacement

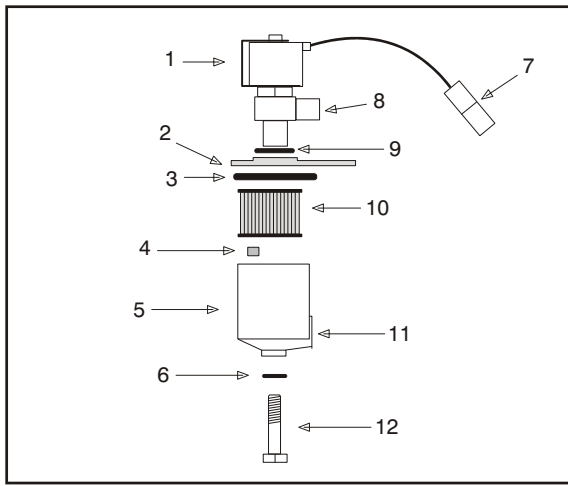

- | | |
|-------------------------------|-------------------------|
| 1. Electric Lock Off Solenoid | 7. Electrical Connector |
| 2. Mounting Plate | 8. Fuel Outlet |
| 3. Housing Seal | 9. O-ring |
| 4. Filter Magnet | 10. Filter |
| 5. Filter Housing | 11. Fuel Inlet |
| 6. Seal | 12. Retaining Bolt |

Figure 1-3. Filter Lock Assembly

REMOVAL:

- Relieve the propane fuel system pressure. Refer to Propane Fuel System Pressure Relief.
- Disconnect the negative battery cable.
- Slowly loosen the Filter housing retaining bolt and remove it.
- Pull the filter housing from the Electric lock off assembly.
- Locate Filter magnet and remove it.
- Remove the filter from the housing.
- Remove and discard the housing seal.
- Remove and discard the retaining bolt seal.
- Remove and discard mounting plate to lock off O-ring seal.

INSTALLATION:

NOTICE

BE SURE TO REINSTALL THE FILTER MAGNET INTO THE HOUSING BEFORE INSTALLING NEW SEAL.

- Install the mounting plate to lock off O-ring seal.
- Install the retaining bolt seal.
- Install the housing seal.
- Drop the magnet into the bottom of the filter housing.
- Install the filter into the housing.
- Install the retaining bolt into the filter housing.
- Install the filter up to the bottom of the electric lock off.
- Tighten the filter retaining bolt to 106 in.lbs. (12 Nm).
- Open manual shut-off valve. Start the vehicle and leak check the propane fuel system at each serviced fitting. Refer to Propane Fuel System Leak Test.

Propane Fuel System Pressure Relief

CAUTION

THE PROPANE FUEL SYSTEM OPERATES AT PRESSURES UP TO 312 PSI (21.5 BAR). TO MINIMIZE THE RISK OF FIRE AND PERSONAL INJURY, RELIEVE THE PROPANE FUEL SYSTEM PRESSURE (WHERE APPLICABLE) BEFORE SERVICING THE PROPANE FUEL SYSTEM COMPONENTS.

To relieve propane fuel system pressure:

- Close the manual shut-off valve on the propane fuel tank.
- Start and run the vehicle until the engine stalls.
- Turn the ignition switch OFF.

CAUTION

RESIDUAL VAPOR PRESSURE WILL BE PRESENT IN THE FUEL SYSTEM. ENSURE THE WORK AREA IS WELL VENTILATED BEFORE DISCONNECTING ANY FUEL LINE.

1.14 TORQUE CHARTS

Values for Zinc Yellow Chromate Fasteners (Ref 4150707)																							
Size	TPI	Bolt Dia	Tensile Stress Area	Clamp Load			Torque (Dry)		Torque Lubricated		Torque (Locitite® 242™ or 271™ OR Vibra-TITE™ 111 or 140)		Torque (Locitite® 262™ or Vibra-TITE™ 131)		Clamp Load		Torque (Dry or Locitite® 263) K= 0.20		Torque (Locitite® 242™ or 271™ OR Vibra-TITE™ 111 or 140) K= 0.18		Torque (Locitite® 262™ or Vibra-TITE™ 131) K=0.15		
				LB	IN-LB	[N.m]	IN-LB	[N.m]	IN-LB	[N.m]	IN-LB	[N.m]	IN-LB	[N.m]	IN-LB	[N.m]	IN-LB	[N.m]	IN-LB	[N.m]	IN-LB	[N.m]	IN-LB
4	40	0.1120	0.0694	380	8	0.9	6	0.7															
4.8	48	0.1120	0.0661	420	9	1.0	7	0.8															
6	32	0.1380	0.0909	590	16	1.8	12	1.4															
8	40	0.1380	0.1015	610	18	2.0	13	1.5															
8	32	0.1640	0.1400	900	30	3.4	22	2.5															
10	36	0.1640	0.1474	940	31	3.5	23	2.6															
10	24	0.1900	0.01750	1220	43	4.8	32	3.5															
1/4	32	0.1900	0.02000	1265	49	5.5	36	4															
1/4	20	0.2500	0.0318	2020	96	10.8	75	9	105	12													
1/4	28	0.2500	0.0364	2320	120	13.5	86	10	135	15													
5/16	18	0.3125	0.0524	3340	17	23	13	18	19	26													
5/16	24	0.3125	0.0560	3700	19	26	14	19	21	29													
3/8	16	0.3750	0.0775	4940	30	41	23	31	35	48													
3/8	24	0.3750	0.0878	5600	35	47	25	34	40	54													
7/16	14	0.4375	0.1063	6900	50	68	35	47	55	75													
1/2	20	0.4375	0.1187	7950	55	75	40	54	60	82													
1/2	13	0.5000	0.1419	9050	75	102	55	75	85	116													
9/16	20	0.5000	0.1599	10700	90	122	65	88	100	136													
9/16	12	0.5625	0.1820	11600	110	149	80	108	120	163													
1 1/8	18	0.5625	0.2030	12950	120	163	90	122	135	184													
5/8	11	0.6250	0.2260	14400	150	203	110	149	165	224													
1 1/4	18	0.6250	0.2560	16300	170	230	130	176	190	258													
3/4	10	0.7500	0.3340	21300	260	353	200	285	300	388													
3/4	16	0.7500	0.3730	23800	300	407	220	298	330	449													
7/8	9	0.8750	0.4620	29400	430	563	320	434	475	646													
1 1/2	14	0.8750	0.5090	32400	470	637	350	475	520	707													
1	8	1.0000	0.6060	36600	640	868	480	651	719	975													
1 1/8	12	1.0000	0.6630	42200	700	949	530	719	795	1000													
1 1/8	7	1.1250	0.7630	42300	800	1085	600	813	840	1142													
1 1/4	12	1.2500	0.8560	47500	880	1193	660	895	925	1258													
1 1/4	7	1.2500	0.9690	53800	1120	1518	840	1139	1175	1598													
1 3/8	6	1.2500	1.0730	59600	1240	1681	920	1247	1300	1768													
1 3/8	12	1.3750	1.1550	64100	1460	1979	1100	1491	1525	2074													
1 1/2	12	1.3750	1.3150	73000	1680	2278	1260	1708	1760	2390													
1 1/2	6	1.5000	1.4650	78000	1940	2630	1460	1979	2025	2754													
1 1/2	12	1.5000	1.5800	87700	2200	2963	1640	2224	2300	3128													

NO. 500059 REV. K

NOTES: 1. THESE TORQUE VALUES DO NOT APPLY TO CADMIUM PLATED FASTENERS
 2. ALL TORQUE VALUES ARE STATIC TORQUE MEASURED PER STANDARD AUDIT METHODS TOLERANCE = ±10%
 3. * ASSEMBLY USES HARDENED WASHER

Figure 1-4. Torque Chart - Sheet 1 of 5 - (SAE Fasteners)

SECTION 1 - SPECIFICATIONS

Values for Magni Coating Fasteners (Ref 4150701)																			
SAE GRADE 5 BOLTS & GRADE 2 NUTS							SAE GRADE 8 (HEX HD) BOLTS & GRADE 8 NUTS*												
Size	TPI	Bolt Dia	Tensile Stress Area	Clamp Load		Torque (Dry) K=0.17		Torque (Locitite® 242™ or 271™ OR Vibra-TITE™ 111 or 140) K=0.16		Torque (Locitite® 262™ or VIBRA-TITE™ 131) K=0.15		Torque (Dry or Locitite® 263) K= 0.17		Torque (Locitite® 242™ or 271™ OR Vibra-TITE™ 111 or 140) K=16		Torque (Locitite® 262™ or VIBRA-TITE™ 131) K=0.15			
				LB	Sq In	IN-LB	[N.m]	IN-LB	[N.m]	IN-LB	[N.m]	IN-LB	[N.m]	IN-LB	[N.m]	IN-LB	[N.m]	IN-LB	[N.m]
4	40	0.1120	0.00604	380	7	0.8													
	48	0.1120	0.00661	420	8	0.9													
6	32	0.1380	0.00909	580	14	1.5													
	40	0.1380	0.01015	610	14	1.6													
8	32	0.1640	0.01400	900	25	2.8													
	36	0.1640	0.01474	940	26	2.9													
10	24	0.1900	0.01750	1120	36	4.1													
	32	0.1900	0.02000	1285	42	4.7													
1/4	20	0.2500	0.0318	2020	86	9.7	80	9											
	28	0.2500	0.0364	2320	99	11.1	95	11											
5/16	18	0.3125	0.0524	3340	15	20	14	19	15	20	15	20	4720	20	25	20	25	20	25
	24	0.3125	0.0580	3700	15	20	15	21	15	20	15	20	5220	25	35	20	25	20	25
3/8	16	0.3750	0.0775	4940	25	35	25	34	25	34	25	34	7000	35	50	35	50	35	50
	24	0.3750	0.0878	5600	30	40	28	38	30	40	25	34	7900	40	55	40	55	35	50
7/16	14	0.4375	0.1063	6800	40	55	40	54	40	54	35	48	9550	60	80	55	75	50	70
	20	0.4375	0.1187	7550	45	60	44	60	40	54	40	54	10700	65	90	60	80	60	80
1/2	13	0.5000	0.1419	9050	65	90	60	82	55	75	55	75	12750	90	120	85	115	80	110
	20	0.5000	0.1599	10700	75	100	71	97	65	88	65	88	14400	100	135	95	130	90	120
9/16	12	0.5625	0.1820	11600	90	120	87	118	80	109	80	109	16400	130	175	125	170	115	155
	18	0.5625	0.2030	12950	105	145	97	132	90	122	90	122	18250	145	195	135	185	130	175
5/8	11	0.6250	0.2260	14400	130	175	120	163	115	156	115	156	20350	180	245	170	230	160	220
	18	0.6250	0.2560	16300	145	195	136	185	125	170	125	170	23000	205	280	190	260	180	245
3/4	10	0.7500	0.3340	21300	225	305	213	290	200	272	200	272	30100	320	435	300	410	280	380
	16	0.7500	0.3730	23800	255	345	238	324	225	306	225	306	33600	355	485	335	455	315	430
7/8	9	0.8750	0.4620	29400	365	485	343	466	320	435	320	435	41600	515	700	485	660	455	620
	14	0.8750	0.5090	32400	400	545	378	514	355	483	355	483	45800	570	775	535	730	500	680
1	8	1.0000	0.6060	38600	545	740	515	700	480	653	480	653	51500	730	995	685	930	645	875
1 1/8	7	1.1250	0.6630	42300	600	815	563	765	530	721	530	721	59700	845	1150	795	1080	745	1015
	12	1.1250	0.7630	47500	755	1025	713	969	670	911	670	911	68700	1095	1490	1030	1400	965	1310
1 1/4	7	1.2500	0.8560	47500	755	1025	713	969	670	911	670	911	77000	1225	1665	1155	1570	1085	1475
	12	1.2500	0.9690	53800	955	1300	897	1219	840	1142	840	1142	87200	1545	2100	1455	1980	1365	1855
1 3/8	6	1.2500	1.0730	59600	1055	1435	993	1351	930	1265	930	1265	96600	1710	2325	1610	2190	1510	2055
	12	1.3750	1.1550	64100	1250	1700	1175	1598	1100	1496	1100	1496	104000	2025	2755	1905	2590	1785	2430
1 3/8	6	1.3750	1.3150	73000	1420	1930	1338	1820	1255	1707	1255	1707	118100	2300	3130	2165	2945	2030	2760
1 1/2	6	1.5000	1.4050	78000	1680	2260	1560	2122	1465	1982	1465	1982	126500	2690	3660	2550	3440	2370	3225
	12	1.5000	1.5800	87700	1865	2535	1754	2385	1645	2237	1645	2237	142200	3020	4105	2845	3870	2665	3625

NO. 500059 REV. K

NOTES: 1. THESE TORQUE VALUES DO NOT APPLY TO CADMIUM PLATED FASTENERS
 2. ALL TORQUE VALUES ARE STATIC TORQUE MEASURED PER STANDARD AUDIT METHODS TOLERANCE = ±10%
 3. * ASSEMBLY USES HARDENED WASHER

Figure 1-5. Torque Chart - Sheet 2 of 5 - (SAE Fasteners)

SOCKET HEAD CAP SCREWS														
Magni Coating (Ref 4150701)*						Zinc Yellow Chromate Fasteners (Ref 4150707)*								
Size	TPI	Bolt Dia	Tensile Stress Area	Clamp Load See Note 4	Torque (Dry) K = .17	Torque (Loctite® 242™ or 271™ OR Vibra-TITE™ 111 or 140 OR Precoat 85®) K=0.16		Torque (Loctite® 262™ or 271™ OR Vibra-TITE™ 111 or 140 OR Precoat 85®) K=0.15		Clamp Load See Note 4	Torque (Dry) K = .20	Torque (Loctite® 242™ or 271™ OR Vibra-TITE™ 111 or 140 OR Precoat 85®) K=0.18		Torque (Loctite® 262™ or 271™ OR Vibra-TITE™ 111 or 140 OR Precoat 85®) K=0.15
						IN-LB	FT-LB	IN-LB	FT-LB			IN-LB	FT-LB	
4	40	0.1120	0.00604											
	48	0.1120	0.00661											
6	32	0.1380	0.0909											
	40	0.1380	0.01015											
8	32	0.1640	0.01400											
	36	0.1640	0.01474											
10	24	0.1900	0.01750											
	32	0.1900	0.02000											
1/4	20	0.2500	0.0318	2860	122	14	114	13		2860	143	16	129	15
	28	0.2500	0.0364	3280	139	16	131	15		3280	164	19	148	17
5/16	18	0.3125	0.0524	4720	20	25	20	25	20	4720	25	35	20	25
	24	0.3125	0.0580	5220	35	35	20	25	20	5220	25	35	25	25
3/8	16	0.3750	0.0775	7000	35	50	35	50	35	7000	45	60	40	55
	24	0.3750	0.0878	7900	40	55	40	55	40	7900	50	70	45	60
7/16	14	0.4375	0.1063	9550	60	80	55	75	50	9550	70	95	60	70
	20	0.4375	0.1187	10700	65	90	60	80	60	10700	80	110	70	95
1/2	13	0.5000	0.1419	12750	90	120	85	115	80	12750	105	145	95	130
	20	0.5000	0.1599	14400	100	135	95	130	90	14400	120	165	110	150
9/16	12	0.5625	0.1820	16400	130	175	125	170	115	16400	155	210	140	190
	18	0.5625	0.2030	18250	145	195	135	185	130	18250	170	230	155	210
5/8	11	0.6250	0.2260	20350	180	245	170	230	160	20350	210	285	190	260
	18	0.6250	0.2560	23000	205	280	190	260	180	23000	240	325	215	290
3/4	10	0.7500	0.3340	30100	320	435	300	400	280	30100	375	510	340	460
	16	0.7500	0.3730	33600	355	485	335	455	315	33600	420	570	380	515
7/8	9	0.8750	0.4620	41600	515	700	485	660	455	41600	605	825	545	740
	14	0.8750	0.5090	45800	570	775	535	730	500	45800	670	910	600	815
1	8	1.0000	0.6060	51500	730	995	685	930	645	51500	860	1170	775	1055
	12	1.0000	0.6630	59700	845	1150	795	1080	745	59700	995	1355	895	1215
1 1/8	7	1.1250	0.7630	68700	1095	1490	1030	1400	965	68700	1290	1755	1160	1580
	12	1.1250	0.8560	77000	1225	1665	1155	1570	1085	77000	1445	1965	1300	1770
1 1/4	7	1.2500	0.9690	87200	1545	2100	1455	1980	1365	87200	1815	2470	1635	2225
	12	1.2500	1.0730	96600	1710	2325	1610	2190	1510	96600	2015	2740	1810	2460
1 3/8	6	1.3750	1.1550	104000	2025	2755	1905	2590	1785	104000	2385	3245	2145	2915
	12	1.3750	1.3150	118100	2300	3130	2165	2945	2030	118100	2765	3680	2435	3310
1 1/2	6	1.5000	1.4050	126500	2690	3660	2530	3440	2370	126500	3165	4305	2845	3870
	12	1.5000	1.5800	142200	3020	4105	2845	3870	2665	142200	3555	4835	3200	4350

NO. 500059 REV. K

NOTES: 1. THESE TORQUE VALUES DO NOT APPLY TO CADMIUM PLATED FASTENERS
 2. ALL TORQUE VALUES ARE STATIC TORQUE MEASURED PER STANDARD AUDIT METHODS TOLERANCE = +10%
 *3. ASSEMBLY USES HARDENED WASHER OR FASTENER IS PLACED AGAINST PLATED STEEL OR RAW ALUMINUM
 4. CLAMP LOAD LISTED FOR SHCS IS SAME AS GRADE 8 OR CLASS 10.9 AND DOES NOT REPRESENT FULL STRENGTH CAPABILITY OF SHCS. IF HIGHER LOAD IS REQUIRED, ADDITIONAL TESTING IS REQUIRED.

Figure 1-6. Torque Chart - Sheet 3 of 5 - (SAE Fasteners)

Values for Zinc Yellow Chromate Fasteners (Ref 4150707)											
CLASS 8.8 METRIC (HEX/SOCKET HEAD) BOLTS CLASS 8 METRIC NUTS					CLASS 10.9 METRIC (HEX HEAD) BOLTS CLASS 10 METRIC NUTS CLASS 12.9 SOCKET HEAD CAP SCREWS M3 - M5*						
Size	PITCH	Tensile Stress Area	Clamp Load	Torque (Dry or Loctite® 263™)	Torque (Lub)	Torque (Loctite® 262™ OR Vibra-TITE™ 131)	Torque (Loctite® 242™ or 271™ OR Vibra-TITE™ 111 or 140)	Clamp Load	Torque (Dry or Loctite® 263™) K = 0.20	Torque (Lub OR Loctite® 242™ or 271™ OR Vibra-TITE™ 111 or 140) K = 0.18	Torque (Loctite® 262™ OR Vibra-TITE™ 131) K=0.15
		Sq mm	KN	[N.m]	[N.m]	[N.m]	[N.m]	KN	[N.m]	[N.m]	[N.m]
3	0.5	5.03	2.19	1.3	1.0	1.2	1.4	3.13			
3.5	0.6	6.78	2.95	2.1	1.6	1.9	2.3	4.22			
4	0.7	8.78	3.82	3.1	2.3	2.8	3.4	5.47			
5	0.8	14.20	6.18	6.2	4.6	5.6	6.8	8.85			
6	1	20.10	8.74	11	7.9	9.4	12	12.5			
7	1	28.90	12.6	18	13	16	19	18.0	25	23	19
8	1.25	36.60	15.9	26	19	23	28	22.8	37	33	27
10	1.5	58.00	25.2	50	38	45	55	36.1	70	65	55
12	1.75	84.30	36.7	88	66	79	97	52.5	125	115	95
14	2	115	50.0	140	105	126	154	71.6	200	180	150
16	2	157	68.3	219	164	197	241	97.8	315	280	235
18	2.5	192	83.5	301	226	271	331	119.5	430	385	325
20	2.5	245	106.5	426	320	383	469	152.5	610	550	460
22	2.5	303	132.0	581	436	523	639	189.0	830	750	625
24	3	353	153.5	737	553	663	811	222.0	1065	960	800
27	3	459	199.5	1080	810	970	1130	286.0	1545	1390	1160
30	3.5	561	244.0	1460	1100	1320	1530	349.5	2095	1885	1575
33	3.5	694	302.0	1990	1490	1790	2090	432.5	2855	2570	2140
36	4	817	355.5	2560	1920	2300	2690	509.0	3665	3300	2750
42	4.5	1120	487.0	4090	3070	3680	4290	698.0	5865	5275	4395

NO. 500059 REV. K

- NOTES: 1. THESE TORQUE VALUES DO NOT APPLY TO CADMIUM PLATED FASTENERS
 2. ALL TORQUE VALUES ARE STATIC TORQUE MEASURED PER STANDARD AUDIT METHODS TOLERANCE = ±10%
 *3. ASSEMBLY USES HARDENED WASHER OR FASTENER IS PLACED AGAINST PLATED STEEL OR RAW ALUMINUM
 4. CLAMP LOAD LISTED FOR SHCS IS SAME AS GRADE 8 OR CLASS 10.9 AND DOES NOT REPRESENT FULL-STRENGTH CAPABILITY OF SHCS. IF HIGHER LOAD IS REQUIRED, ADDITIONAL TESTING IS REQUIRED.

Figure 1-7. Torque Chart - Sheet 4 of 5 - (METRIC Fasteners)

Values for Magni Coated Fasteners (Ref 4150701)										
CLASS 8.8 METRIC (HEX/SOCKET HEAD) BOLTS CLASS 8 METRIC NUTS					CLASS 10.9 METRIC (HEX HEAD) BOLTS CLASS 10 METRIC NUTS CLASS 12.9 SOCKET HEAD CAP SCREWS M6 AND ABOVE*					
Size	PITCH	Tensile Stress Area	Clamp Load	Torque (Dry or Loctite® 263™) K=0.17	Torque (Loctite® 262™ OR Vibra-TITE™ 131) K=0.16	Torque (Loctite® 242™ or 271™ OR Vibra-TITE™ 111 or 140) K=0.15	Clamp Load	Torque (Dry or Loctite® 263™) K = 0.17	Torque (Lub OR Loctite® 242™ or 271™ OR Vibra-TITE™ 111 or 140) K= 0.16	Torque (Loctite® 262™ OR Vibra-TITE™ 131) K=0.15
		Sq mm	KN	[N.m]	[N.m]	[N.m]	KN	[N.m]	[N.m]	[N.m]
3	0.5	5.03	2.19	1.1	1.1	1.0	3.13			
3.5	0.6	6.78	2.95	1.8	1.7	1.5	4.22			
4	0.7	8.78	3.82	2.6	2.4	2.3	5.47			
5	0.8	14.20	6.18	5.3	4.9	4.6	8.85			
6	1	20.10	8.74	9	8.4	7.9	12.5	13	12	11
7	1	28.90	12.6	15	14	13	18.0	21	20	19
8	1.25	36.60	15.9	22	20	19	22.8	31	29	27
10	1.5	58.00	25.2	43	40	38	36.1	61	58	55
12	1.75	84.30	36.7	75	70	66	52.5	105	100	95
14	2	115	50.0	119	110	105	71.6	170	160	150
16	2	157	68.3	186	175	165	97.8	265	250	235
18	2.5	192	83.5	256	240	225	119.5	365	345	325
20	2.5	245	106.5	362	340	320	152.5	520	490	460
22	2.5	303	132.0	494	465	435	189.0	705	665	625
24	3	353	153.5	627	590	555	222.0	905	850	800
27	3	459	199.5	916	860	810	286.0	1315	1235	1160
30	3.5	561	244.0	1245	1170	1100	349.5	1780	1680	1575
33	3.5	694	302.0	1694	1595	1495	432.5	2425	2285	2140
36	4	817	355.5	2176	2050	1920	509.0	3115	2930	2750
42	4.5	1120	487.0	3477	3275	3070	698.0	4985	4690	4395

NOTES: 1. THESE TORQUE VALUES DO NOT APPLY TO CADMIUM PLATED FASTENERS

2. ALL TORQUE VALUES ARE STATIC TORQUE MEASURED PER STANDARD AUDIT METHODS TOLERANCE = ±10%

*3. ASSEMBLY USES HARDENED WASHER OR FASTENER IS PLACED AGAINST PLATED STEEL OR RAW ALUMINUM

4. CLAMP LOAD LISTED FOR SHCS IS SAME AS GRADE 8 OR CLASS 10.9 AND DOES NOT REPRESENT FULL STRENGTH CAPABILITY OF SHCS. IF HIGHER LOAD IS REQUIRED, ADDITIONAL TESTING IS REQUIRED.

NO. 500059 REV. K

Figure 1-8. Torque Chart - Sheet 5 of 5 - (METRIC Fasteners)

SECTION 2. GENERAL

2.1 MACHINE PREPARATION, INSPECTION, AND MAINTENANCE

General

This section provides the necessary information needed by those personnel that are responsible to place the machine in operation readiness and maintain its safe operating condition. For maximum service life and safe operation, ensure that all the necessary inspections and maintenance have been completed before placing the machine into service.

Preparation, Inspection, and Maintenance

It is important to establish and conform to a comprehensive inspection and preventive maintenance program. The following table outlines the periodic machine inspections and maintenance recommended by JLG Industries, Inc. Consult your national, regional, or local regulations for further requirements for aerial work platforms. The frequency of inspections and maintenance must be increased as environment, severity and frequency of usage requires.

Pre-Start Inspection

It is the User's or Operator's primary responsibility to perform a Pre-Start Inspection of the machine prior to use daily or at each change of operator. Reference the Operator's and Safety Manual for completion procedures for the Pre-Start Inspection. The Operator and Safety Manual must be read in its entirety and understood prior to performing the Pre-Start Inspection.

Pre-Delivery Inspection and Frequent Inspection

The Pre-Delivery Inspection and Frequent Inspection shall be performed by a qualified JLG equipment mechanic. JLG Industries, Inc. recognizes a qualified JLG equipment mechanic as a person who, by possession of a recognized degree, certificate, extensive knowledge, training, or experience, has successfully demonstrated the ability and proficiency to service, repair, and maintain the subject JLG product model.

The Pre-Delivery Inspection and Frequent Inspection procedures are performed in the same manner, but at different times. The Pre-Delivery Inspection shall be performed prior to each sale, lease, or rental delivery. The Frequent Inspection shall be accomplished for each machine in service for 3 months or 150 hours (whichever comes first); out of service for a period of more than 3 months; or when purchased used. The frequency of this inspection must be increased as environment, severity and frequency of usage requires.

Reference the JLG Pre-Delivery and Frequent Inspection Form and the Inspection and Preventative Maintenance Schedule for items requiring inspection during the performance of these inspections. Reference the appropriate areas of this manual for servicing and maintenance procedures.

Annual Machine Inspection

JLG recommends that an annual machine inspection be performed by a Factory-Certified Service Technician on an annual basis, no later than thirteen (13) months from the date of the prior Annual Machine Inspection. JLG Industries, Inc. recognizes a Factory-Certified Service Technician as a person who has successfully completed the JLG Service Training School for the subject JLG product model. Reference the machine Service and Maintenance Manual and appropriate JLG inspection form for performance of this inspection.

Reference the JLG Annual Machine Inspection Form and the Inspection and Preventative Maintenance Schedule for items requiring inspection during the performance of this inspection. Reference the appropriate areas of this manual for servicing and maintenance procedures.

For the purpose of receiving safety-related bulletins, it is important that JLG Industries, Inc. has updated ownership information for each machine. When performing each Annual Machine Inspection, notify JLG Industries, Inc. of the current machine ownership.

Preventative Maintenance

In conjunction with the specified inspections, maintenance shall be performed by a qualified JLG equipment mechanic. JLG Industries, Inc. recognizes a qualified JLG equipment mechanic as a person who, by possession of a recognized degree, certificate, extensive knowledge, training, or experience, has successfully demonstrated the ability and proficiency to service, repair, and maintain the subject JLG product model.

Reference the Preventative Maintenance Schedule and the appropriate areas of this manual for servicing and maintenance procedures. The frequency of service and maintenance must be increased as environment, severity and frequency of usage requires.

Table 2-1. Inspection and Maintenance

Type	Frequency	Primary Responsibility	Service Qualification	Reference
Pre-Start Inspection	Prior to use each day; or At each Operator change.	User or Operator	User or Operator	Operator and Safety Manual
Pre-Delivery Inspection	Prior to each sale, lease, or rental delivery.	Owner, Dealer, or User	Qualified JLG Mechanic	Service and Maintenance Manual and applicable JLG inspection form.
Frequent Inspection	In service for 3 months or 150 hours, whichever comes first; or Out of service for a period of more than 3 months; or Purchased used.	Owner, Dealer, or User	Qualified JLG Mechanic	Service and Maintenance Manual and applicable JLG inspection form.
Annual Machine Inspection	Annually, no later than 13 months from the date of the prior inspection.	Owner, Dealer, or User	Factory-Certified Service Technician or a Qualified JLG Mechanic	Service and Maintenance Manual and applicable JLG inspection form.
Preventative Maintenance	At intervals as specified in the Service and Maintenance Manual.	Owner, Dealer, or User	Qualified JLG Mechanic	Service and Maintenance Manual

2.2 SERVICE AND GUIDELINES

General

The following information is provided to assist you in the use and application of servicing and maintenance procedures contained in this book.

Safety and Workmanship

Your safety, and that of others, is the first consideration when engaging in the maintenance of equipment. Always be conscious of weight. Never attempt to move heavy parts without the aid of a mechanical device. Do not allow heavy objects to rest in an unstable position. When raising a portion of the equipment, ensure that adequate support is provided.

Cleanliness

1. The most important single item in preserving the long service life of a machine is to keep dirt and foreign materials out of the vital components. Precautions have been taken to safeguard against this. Shields, covers, seals, and filters are provided to keep air, fuel, and oil supplies clean; however, these items must be maintained on a scheduled basis in order to function properly.

2. At any time when air, fuel, or oil lines are disconnected, clear adjacent areas as well as the openings and fittings themselves. As soon as a line or component is disconnected, cap or cover all openings to prevent entry of foreign matter.
3. Clean and inspect all parts during servicing or maintenance, and assure that all passages and openings are unobstructed. Cover all parts to keep them clean. Be sure all parts are clean before they are installed. New parts should remain in their containers until they are ready to be used.

Components Removal and Installation

1. Use adjustable lifting devices, whenever possible, if mechanical assistance is required. All slings (chains, cables, etc.) should be parallel to each other and as near perpendicular as possible to top of part being lifted.
2. Should it be necessary to remove a component on an angle, keep in mind that the capacity of an eye-bolt or similar bracket lessens, as the angle between the supporting structure and the component becomes less than 90°.
3. If a part resists removal, check to see whether all nuts, bolts, cables, brackets, wiring, etc., have been removed and that no adjacent parts are interfering.

Component Disassembly and Reassembly

When disassembling or reassembling a component, complete the procedural steps in sequence. Do not partially disassemble or assemble one part, then start on another. Always recheck your work to assure that nothing has been overlooked. Do not make any adjustments, other than those recommended, without obtaining proper approval.

Pressure-Fit Parts

When assembling pressure-fit parts, use an anti-seize or molybdenum disulfide base compound to lubricate the mating surface.

Bearings

1. When a bearing is removed, cover it to keep out dirt and abrasives. Clean bearings in nonflammable cleaning solvent and allow to drip dry. Compressed air can be used but do not spin the bearing.
2. Discard bearings if the races and balls (or rollers) are pitted, scored, or burned.
3. If bearing is found to be serviceable, apply a light coat of oil and wrap it in clean (waxed) paper. Do not unwrap reusable or new bearings until they are ready to install.
4. Lubricate new or used serviceable bearings before installation. When pressing a bearing into a retainer or bore, apply pressure to the outer race. If the bearing is to be installed on a shaft, apply pressure to the inner race.

Gaskets

Check that holes in gaskets align with openings in the mating parts. If it becomes necessary to hand-fabricate a gasket, use gasket material or stock of equivalent material and thickness. Be sure to cut holes in the right location, as blank gaskets can cause serious system damage.

Bolt Usage and Torque Application

1. Use bolts of proper length. A bolt which is too long will bottom before the head is tight against its related part. If a bolt is too short, there will not be enough thread area to engage and hold the part properly. When replacing bolts, use only those having the same specifications of the original, or one which is equivalent.

2. Unless specific torque requirements are given within the text, standard torque values should be used on heat-treated bolts, studs, and steel nuts, in accordance with recommended shop practices. (See Torque Chart Section 1.)

Hydraulic Lines and Electrical Wiring

Clearly mark or tag hydraulic lines and electrical wiring, as well as their receptacles, when disconnecting or removing them from the unit. This will assure that they are correctly reinstalled.

Hydraulic System

1. Keep the system clean. If evidence of metal or rubber particles are found in the hydraulic system, drain and flush the entire system.
2. Disassemble and reassemble parts on clean work surface. Clean all metal parts with non-flammable cleaning solvent. Lubricate components, as required, to aid assembly.

Lubrication

Service applicable components with the amount, type, and grade of lubricant recommended in this manual, at the specified intervals. When recommended lubricants are not available, consult your local supplier for an equivalent that meets or exceeds the specifications listed.

Battery

Clean battery, using a non-metallic brush and a solution of baking soda and water. Rinse with clean water. After cleaning, thoroughly dry battery and coat terminals with an anti corrosion compound.

Lubrication and Servicing

Components and assemblies requiring lubrication and servicing are shown in the Lubrication Chart in Section 1.

2.3 LUBRICATION AND INFORMATION

Hydraulic System

1. The primary enemy of a hydraulic system is contamination. Contaminants enter the system by various means, e.g., using inadequate hydraulic oil, allowing moisture, grease, filings, sealing components, sand, etc., to enter when performing maintenance, or by permitting the pump to cavitate due to insufficient system warm-up or leaks in the pump supply (suction) lines.
2. The design and manufacturing tolerances of the component working parts are very close, therefore, even the smallest amount of dirt or foreign matter entering a system can cause wear or damage to the components and generally results in faulty operation. Every precaution must be taken to keep hydraulic oil clean, including reserve oil in storage. Hydraulic system filters should be checked, cleaned, and/or replaced as necessary, at the specified intervals required in the Lubrication Chart in Section 1. Always examine filters for evidence of metal particles.
3. Cloudy oils indicate a high moisture content which permits organic growth, resulting in oxidation or corrosion. If this condition occurs, the system must be drained, flushed, and refilled with clean oil.
4. It is not advisable to mix oils of different brands or types, as they may not contain the same required additives or be of comparable viscosities. Good grade mineral oils, with viscosities suited to the ambient temperatures in which the machine is operating, are recommended for use.

NOTE: *Metal particles may appear in the oil or filters of new machines due to the wear-in of meshing components.*

Hydraulic Oil

1. Refer to Section 1 for recommendations for viscosity ranges.
2. JLG recommends Mobilfluid 424 hydraulic oil, which has an SAE viscosity of 10W-30 and a viscosity index of 152.

NOTE: *Start-up of hydraulic system with oil temperatures below -15°F (-26°C) is not recommended. If it is necessary to start the system in a sub-zero environment, it will be necessary to heat the oil with a low density, 100VAC heater to a minimum temperature of -15°F (-26°C).*

3. The only exception to the above is to drain and fill the system with Mobil DTE 13 oil or its equivalent. This will allow start up at temperatures down to -20°F (-29°C). However, use of this oil will give poor performance at temperatures above 120°F (49°C). Systems using DTE 13 oil should not be operated at temperatures above 200°F (94°C) under any condition.

Changing Hydraulic Oil

1. Use of any of the recommended hydraulic oils eliminates the need for changing the oil on a regular basis. However, filter elements must be changed after the first 50 hours of operation and every 300 hours thereafter. If it is necessary to change the oil, use only those oils meeting or exceeding the specifications appearing in this manual. If unable to obtain the same type of oil supplied with the machine, consult local supplier for assistance in selecting the proper equivalent. Avoid mixing petroleum and synthetic base oils. JLG Industries recommends changing the hydraulic oil annually.
2. Use every precaution to keep the hydraulic oil clean. If the oil must be poured from the original container into another, be sure to clean all possible contaminants from the service container. Always clean the mesh element of the filter and replace the cartridge any time the system oil is changed.
3. While the unit is shut down, a good preventive maintenance measure is to make a thorough inspection of all hydraulic components, lines, fittings, etc., as well as a functional check of each system, before placing the machine back in service.

Lubrication Specifications

Specified lubricants, as recommended by the component manufacturers, are always the best choice, however, multi-purpose greases usually have the qualities which meet a variety of single purpose grease requirements. Should any question arise, regarding the use of greases in maintenance stock, consult your local supplier for evaluation. Refer to Section 1 for an explanation of the lubricant key designations appearing in the Lubrication Chart.

2.4 CYLINDER DRIFT TEST

Maximum acceptable cylinder drift is to be measured using the following methods.

Platform Drift

Measure the drift of the platform to the ground. Lower booms (if equipped) slightly elevated, upper boom fully extended with the rated load in the platform and power off. Maximum allowable drift is 2 in (5 cm) in 10 minutes. If the machine does not pass this test, proceed with the following.

Cylinder Drift

Table 2-2. Cylinder Drift

Cylinder Bore Diameter		Max. Acceptable Drift in 10 Minutes	
inches	mm	inches	mm
3	76.2	0.026	0.66
3.5	89	0.019	0.48
4	101.6	0.015	0.38
5	127	0.009	0.22
6	152.4	0.006	0.15
7	177.8	0.005	0.13

Drift is to be measured at the cylinder rod with a calibrated dial indicator. The cylinder oil must be at ambient temperature and temperature stabilized.

The cylinder must have the normal load, which is the normal platform load applied.

If the cylinder passes this test, it is acceptable.

NOTE: This information is based on 6 drops per minute cylinder leakage.

2.5 PINS AND COMPOSITE BEARING REPAIR GUIDELINES

Filament wound bearings.

1. Pinned joints should be disassembled and inspected if the following occurs:
 - a. Excessive sloppiness in joints.
 - b. Noise originating from the joint during operation.
2. Filament wound bearings should be replaced if any of the following is observed:
 - a. Frayed or separated fibers on the liner surface.
 - b. Cracked or damaged liner backing.
 - c. Bearings that have moved or spun in their housing.
 - d. Debris embedded in liner surface.
3. Pins should be replaced if any of the following is observed (pin should be properly cleaned prior to inspection):
 - a. Detectable wear in the bearing area.
 - b. Flaking, peeling, scoring, or scratches on the pin surface.
 - c. Rusting of the pin in the bearing area.
4. Re-assembly of pinned joints using filament wound bearings.
 - a. Housing should be blown out to remove all dirt and debris...bearings and bearing housings must be free of all contamination.
 - b. Bearing / pins should be cleaned with a solvent to remove all grease and oil...filament wound bearing are a dry joint and should not be lubricated.
 - c. Pins should be inspected to ensure it is free of burrs, nicks, and scratches which would damage the bearing during installation and operation.

2.6 PREVENTIVE MAINTENANCE AND INSPECTION SCHEDULE

The preventive maintenance and inspection checks are listed and defined in the following table. This table is divided into two basic parts, the "AREA" to be inspected and the "INTERVAL" at which the inspection is to take place. Under the "AREA" portion of the table, the various systems along with the components that make up that system are listed. The "INTERVAL" portion of the table is divided into five columns representing the various inspection time periods. The numbers listed within the interval column represent the applicable inspection code for which that component is to be checked.

The checks and services listed in this schedule are not intended to replace any local or regional regulations that may pertain to this type of equipment nor should the lists be considered as all inclusive. Variances in interval times may occur due to climate and/or conditions and depending on the location and use of the machine.

JLG Industries requires that a complete annual inspection be performed in accordance with the "Annual Machine Inspection Report" form. Forms are supplied with each new machine and are also available from JLG Customer Service. Form must be completed and returned to JLG Industries.

NOTICE

JLG INDUSTRIES REQUIRES THAT A COMPLETE ANNUAL INSPECTION BE PERFORMED IN ACCORDANCE WITH THE "ANNUAL MACHINE INSPECTION REPORT" FORM.

NOTE: *This machine requires periodic safety and maintenance inspections by a JLG Dealer. A decal located on the frame affords a place to record (stamp) inspection dates. Notify dealer if inspection is overdue.*

The inspection and maintenance code numbers are as follows:

1. Check for proper and secure installation.
2. Check for visible damage and legibility.
3. Check for proper fluid level.
4. Check for any structural damage; cracked or broken welds; bent or warped surfaces.
5. Check for leakage.
6. Check for presence of excessive dirt or foreign material.
7. Check for proper operation and freedom of movement.
8. Check for excessive wear or damage.
9. Check for proper tightness and adjustment.
10. Drain, clean and refill.
11. Check for proper operation while pump/motor is running.
12. Check for proper lubrication.
13. Check for evidence of scratches, nicks or rust and for straightness of rod.
14. Check for condition of element; replace as necessary.
15. Check for proper inflation.
16. Check Inspection Decal for current inspection stamp.

Table 2-3. Preventive Maintenance and Safety Inspection

AREA	INTERVAL				
	Daily	Weekly	300 Hours (6 months)	600 Hours (1 year)	1200 Hours (2 years)
PLATFORM					
1. Controller	1,11				
2. Switches	1,11				
3. Placards and Decals	1,2				
4. Control Tags	1,2				
5. Hoses and Cables		4,8			
6. Wear Pads			8		
7. Handrails and Chains	1,4				
CHASSIS					
1. Engine Oil	3	5			
2. Battery	3	5			
3. Air Cleaner	1	14			
4. Exhaust System	1		1,5		
5. Engine Mounts			1		
6. Hydraulic Pump	1	5			
7. Valves	1	5			
8. Hydraulic Filter (See Lubrication Chart)		5,14	14		
9. Hydraulic Hoses and Tubing	1	5			
10. Hydraulic Oil Tank*	3	5	4		
11. Hydraulic Tank Breather		6,14			
12. Fuel Tank	3,5		4		
13. Lift Cylinder	1,12	5,6,13	4		
14. Limit Switch	1,7				
15. Tilt Alarm Switch				1,7	
16. Placards and Decals	1,2				
17. Wheel and Tire Assemblies	1	8,9			
18. Drive Motors		1,5,6			
19. Drive Brakes		1,6	8		
20. Drive Torque Hubs		1,3,5,6			
21. Steer Cylinder	1	5,6,13	4		
22. Steer Components	1	4,6	8		
23. Wheel Bearings (2 Wheel Drive)			8	12	
24. Sizzor Arms	1,4				
25. Safety Props	1,4				
26. Sliding Wear Pads			8		
27. Pivot Pins/Bolts	1,4		7,8		
28. Switches, Ground Control	1,11				
29. Control Tags	1,2				

SECTION 2 - GENERAL

4150548 E

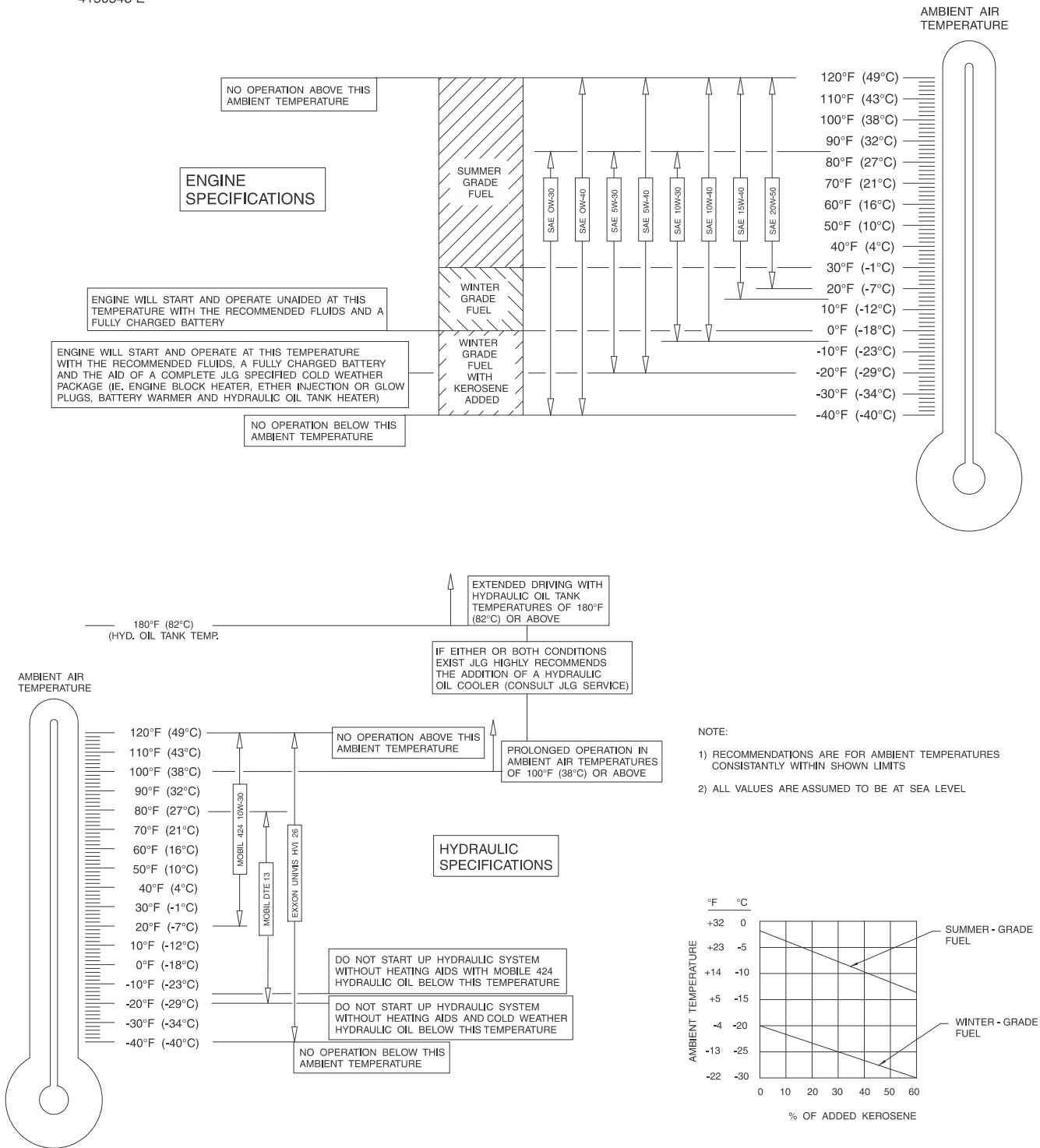

Figure 2-1. Engine Operating Temperature Specifications - Deutz

4150548 E

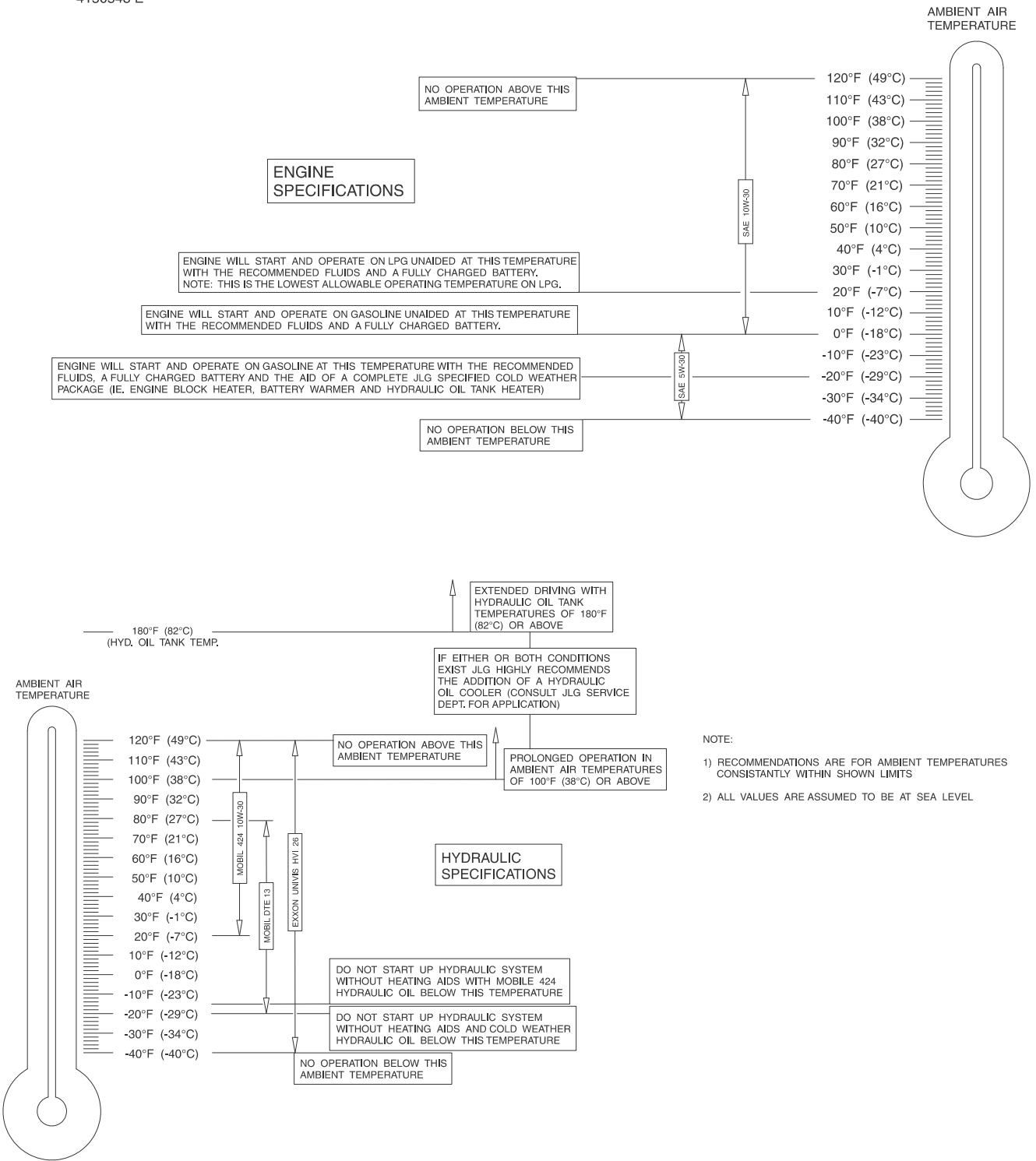

Figure 2-2. Engine Operating Temperature Specifications - GM

SECTION 3. CHASSIS, PLATFORM & SCISSOR ARMS

3.1 OPERATING CHARACTERISTICS

Leveling Jacks

The machine may be equipped with auto leveling jacks. These leveling jacks are operated through one switch unlike the traditional four switch system. The leveling jacks are operated by a bang bang valve.

NOTE: *The engine speed will drop when the leveling jacks are in contact with the ground.*

1. Activate the leveling jack button located on the platform control box.
2. Extend the jacks by moving the joystick forward.

NOTE: *Once all four jacks make contact with the ground the system will go from set mode into level mode. At this point the engine will return to idle.*

3. The tilt indicator will go out once the machine is level.

NOTE: *If the machine is not level it will not lift. If you hit the end of stroke on any of the cylinders you cannot lift the machine.*

NOTE: *There is a limit switch on each cylinder that senses when the cylinder is fully retracted when all four are fully retracted, the stowed light in the platform control box will light.*

If you receive a 2/5 flash code through the system fault light at the platform control station the machine is unable to level. You must reposition and try again.

The jacks are operational (extend or retract) if the machine is in the stowed position. The proximity sensor and rotary sensor together must sense that the machine is stowed. A failure of either sensor will prevent the jacks from being activated.

Power Deck

The power deck is operated through a non proportional valve. This will not effect any other function when activated.

⚠ WARNING

BE SURE AND RETRACT ANY POWER DECK BEFORE LOWERING MACHINE.

Generator

When the generator switch is activated, the engine RPM will increase to 2000 RPM for a 60 Hz generator or 1700 RPM for a 50 Hz generator.

When a function is selected for operation, which requires a higher engine speed than the generator, the generator will automatically shut off during the operation of the function. Once the function has stopped, the generator will be active again.

Lift

There is a flow control valve which controls both the lift up and lift down speeds.

Anytime you abruptly change lift directions, there is a three second delay between lift up and lift down.

Drive

If driving at high drive up a grade and you hit an 8° incline, the drive function will cut back to mid drive speed. The drive pump will shift back into high drive once the incline decreases to 5°. There will be a 2 second delay before the machine goes back into high drive.

3.2 TIRES, WHEELS & DRIVE ASSEMBLY

Tire Inflation

The air pressure for pneumatic tires must be equal to the air pressure that is stenciled on the side of the JLG product or rim decal for safe and proper operational characteristics.

Tire Damage

For pneumatic tires, JLG Industries, Inc. recommends that when any cut, rip, or tear is discovered that exposes sidewall or tread area cords in the tire, measures must be taken to remove the JLG product from service immediately. Arrangements must be made for replacement of the tire or tire assembly.

For polyurethane foam filled tires, JLG Industries, Inc. recommends that when any of the following are discovered, measures must be taken to remove the JLG product from service immediately and arrangements must be made for replacement of the tire or tire assembly.

- a smooth, even cut through the cord plies which exceeds 3 inches (7.5 cm) in total length
- any tears or rips (ragged edges) in the cord plies which exceeds 1 inch (2.5 cm) in any direction
- any punctures which exceed 1 inch in diameter

SECTION 3 - CHASSIS, PLATFORM & SCISSOR ARMS

- any damage to the bead area cords of the tire

If a tire is damaged but is within the above noted criteria, the tire must be inspected on a daily basis to ensure the damage has not propagated beyond the allowable criteria.

Tire Replacement

JLG recommends a replacement tire be the same size, ply and brand as originally installed on the machine. Please refer to the JLG Parts Manual for the part number of the approved tires for a particular machine model. If not using a JLG approved replacement tire, we recommend that replacement tires have the following characteristics:

- Equal or greater ply/load rating and size of original
- Tire tread contact width equal or greater than original
- Wheel diameter, width, and offset dimensions equal to the original
- Approved for the application by the tire manufacturer (including inflation pressure and maximum tire load)

Unless specifically approved by JLG Industries Inc., do not replace a foam filled or ballast filled tire assembly with a pneumatic tire. When selecting and installing a replacement tire, ensure that all tires are inflated to the pressure recommended by JLG. Due to size variations between tire brands, both tires on the same axle should be the same.

Wheel Replacement

The rims installed on each product model have been designed for stability requirements which consist of track width, tire pressure, and load capacity. Size changes such as rim width, center piece location, larger or smaller diameter, etc., without written factory recommendations, may result in an unsafe condition regarding stability.

Wheel Installation

It is extremely important to apply and maintain proper wheel mounting torque.

⚠ WARNING

WHEEL NUTS MUST BE INSTALLED AND MAINTAINED AT THE PROPER TORQUE TO PREVENT LOOSE WHEELS, BROKEN STUDS, AND POSSIBLE DANGEROUS SEPARATION OF WHEEL FROM THE AXLE. BE SURE TO USE ONLY THE NUTS MATCHED TO THE CONE ANGLE OF THE WHEEL.

Tighten the lug nuts to the proper torque to prevent wheels from coming loose. Use a torque wrench to tighten the fasteners. If you do not have a torque wrench, tighten the fasteners with a lug wrench, then immediately have a service garage or dealer tighten the lug nuts to the proper torque. Over-tightening will result in breaking the studs or permanently deforming the mounting stud holes in the wheels. The proper procedure for attaching wheels is as follows:

1. Start all nuts by hand to prevent cross threading. DO NOT use a lubricant on threads or nuts.
2. Tighten nuts in the following sequence:

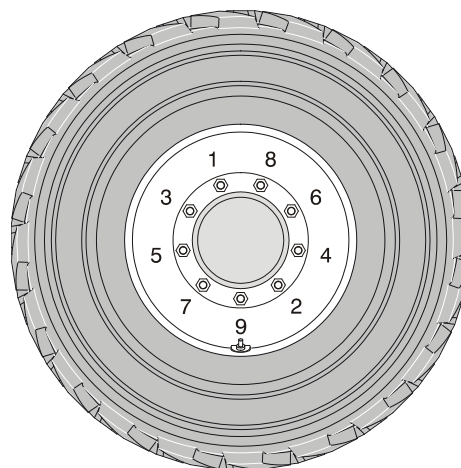

3. The tightening of the nuts should be done in stages. Following the recommended sequence, tighten nuts per wheel torque chart.

Table 3-1. Wheel Torque Chart

TORQUE SEQUENCE		
1st Stage	2nd Stage	3rd Stage
40 lb-ft (55 Nm)	100 lb-ft (136 Nm)	170 lb-ft (230 Nm)

4. Wheel nuts should be torqued after first 50 hours of operation and after each wheel removal. Check torque every 3 months or 150 hours of operation.

Drive Assembly

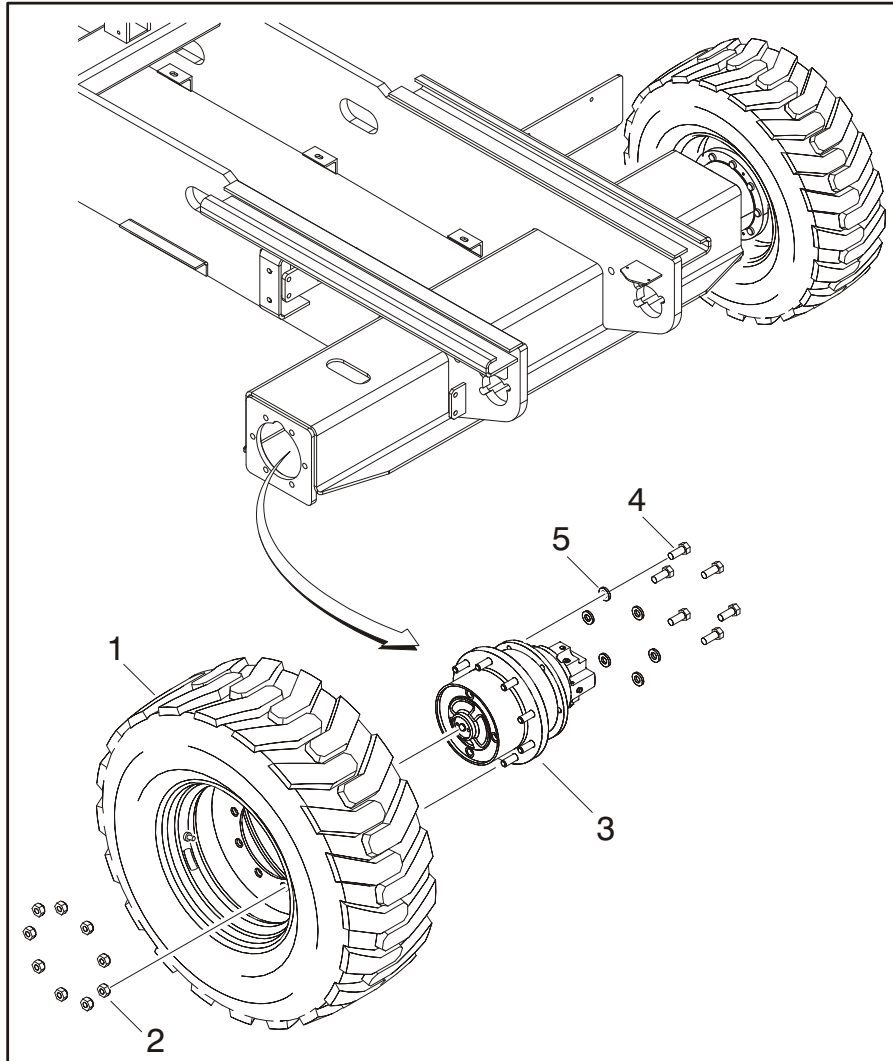

1. Tire & Rim
2. Lugnuts
3. Drive Motor/Hub Assembly (Bosch Rexroth)
4. Bolt, 5/8"-11NC x 1 1/2"
5. Hardened Washer

NOTE: Rear Axle Shown

Figure 3-1. Drive Assembly (Bosch Rexroth)

REMOVAL:



WARNING

SHUT MACHINE OFF, BRACE AXLES AND CHALK WHEELS TO PREVENT MACHINE FROM MOVING DURING REPAIRS.

1. Disconnect, cap and label all hydraulic lines attached to Drive Motor/Hub Assembly (3). If applicable, disconnect all electrical wiring.
2. With axle raised and supported, remove the Tires (1) from the drive motor/hub assembly by removing the 9 Lugnuts (2).
3. Remove the Drive Motor/Hub Assembly (3) by removing the 6 Bolts (4) and Hardened Washers (5).

INSTALLATION:

1. Follow "Removal" procedures in reverse order.
2. Refer to Table 3-1, Wheel Torque Chart when torquing Lugnuts (2).

NOTE: For detailed information on the Drive Motor/Hub Assembly, refer to Section 3.3, Integrated Torque/drive hub (Bosch Rexroth).

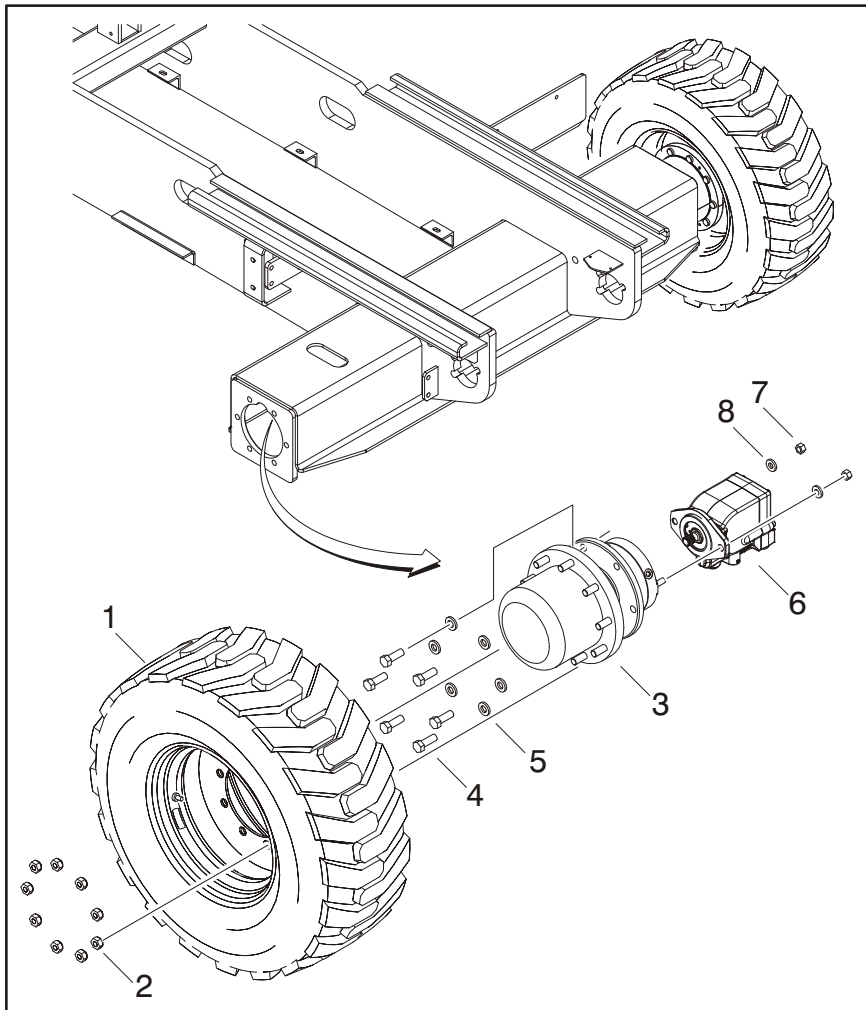

1. Tire & Rim
2. Lugnuts
3. Drive Hub (Fairfield)
4. Bolt, 5/8"-11NC x 1 3/4"
5. Hardened Washer, 5/8"
6. Drive Motor (Sauer)
7. Nut, 1/2"-13NC
8. Hardened Washer, 1/2"

NOTE: Rear Axle Shown

Figure 3-2. Drive Assembly - (Fairfield/Sauer)

REMOVAL:

⚠ WARNING

SHUT MACHINE OFF, BRACE AXLES AND CHALK WHEELS TO PREVENT MACHINE FROM MOVING DURING REPAIRS.

1. Disconnect, cap and label all hydraulic lines attached to Drive Motor (6). If applicable, disconnect all electrical wiring.
2. With axle raised and supported, remove the Tires (1) from the Drive Hub (3) by removing the 9 Lugnuts (2).
3. Remove the Drive Hub (3) and Drive Motor (6) from the axle by removing the 6 Bolts (4) and Washers (5).
4. The Drive Motor (6) can be removed from the Drive Hub (3) by removing the 2 Nuts (7) and Washers (8).

INSTALLATION:

1. Follow "Removal" procedures in reverse order.
2. Refer to Table 3-1, Wheel Torque Chart when torquing Lugnuts (2).

NOTE: For detailed information on the Drive Hub and Drive Motor, refer to Section 3.4, Drive Hub (Fairfield) and Section 3.5, Drive Motor (Sauer).

3.3 INTEGRATED TORQUE/DRIVE HUB (BOSCH REXROTH)

The Integrated Torque/Drive Hub is an axial piston-hydraulic motor with integrated, hydraulic released multi plate parking brake and a 2-stage planetary gearbox and a disconnect mechanism.

To ensure an optimum balancing of loads, each planetary stage is comprised of planet gears in sets. The externally toothed wheels are case-hardened.

The hydraulically released, wet running, multi plate brake, integrated in the hydraulic motor, is a parking brake. It is normally closed by spring force and released when pressurized by hydraulic oil.

NOTICE

TORQUE HUB UNITS SHOULD ALWAYS BE ROLL AND LEAK TESTED BEFORE DISASSEMBLY AND AFTER ASSEMBLY TO MAKE SURE THAT THE UNIT'S GEARS AND SEALANTS ARE WORKING PROPERLY.

Roll Test

The purpose of a roll test is to determine if the unit's gears are rotating freely and properly. Gears should be able to be rotated by applying a constant force to the roll checker. If more drag is felt in the gears only at certain points, then the gears are not rolling freely and should be examined for proper installation or defects. Some gear packages roll with more difficulty than others. Do not be concerned if gears seem to roll hard as long as they roll with consistency.

Leak Test

The purpose of the leak test is to make sure the unit is air tight. The unit has a leak if the pressure gauge reading on the air checker starts to fall once the unit has been pressurized. Leaks will most likely occur at main seal or wherever o-rings or gaskets are located. The exact location of a leak can usually be detected by brushing a soap and water solution around the main seal and where o-rings or gaskets meet the exterior of the unit, then checking for air bubbles. If a leak is detected in a seal, o-ring, or gasket, the part must be replaced.

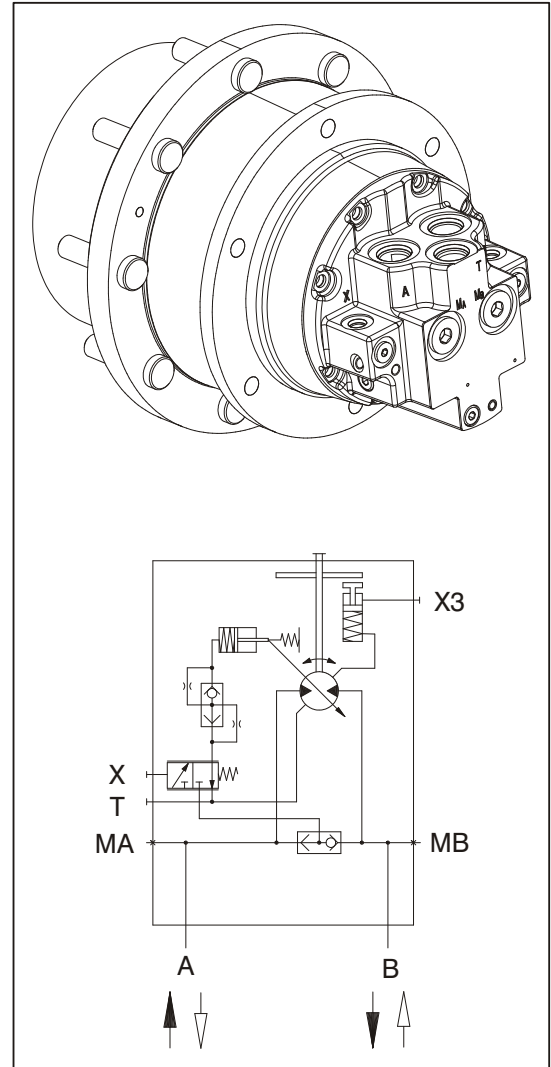
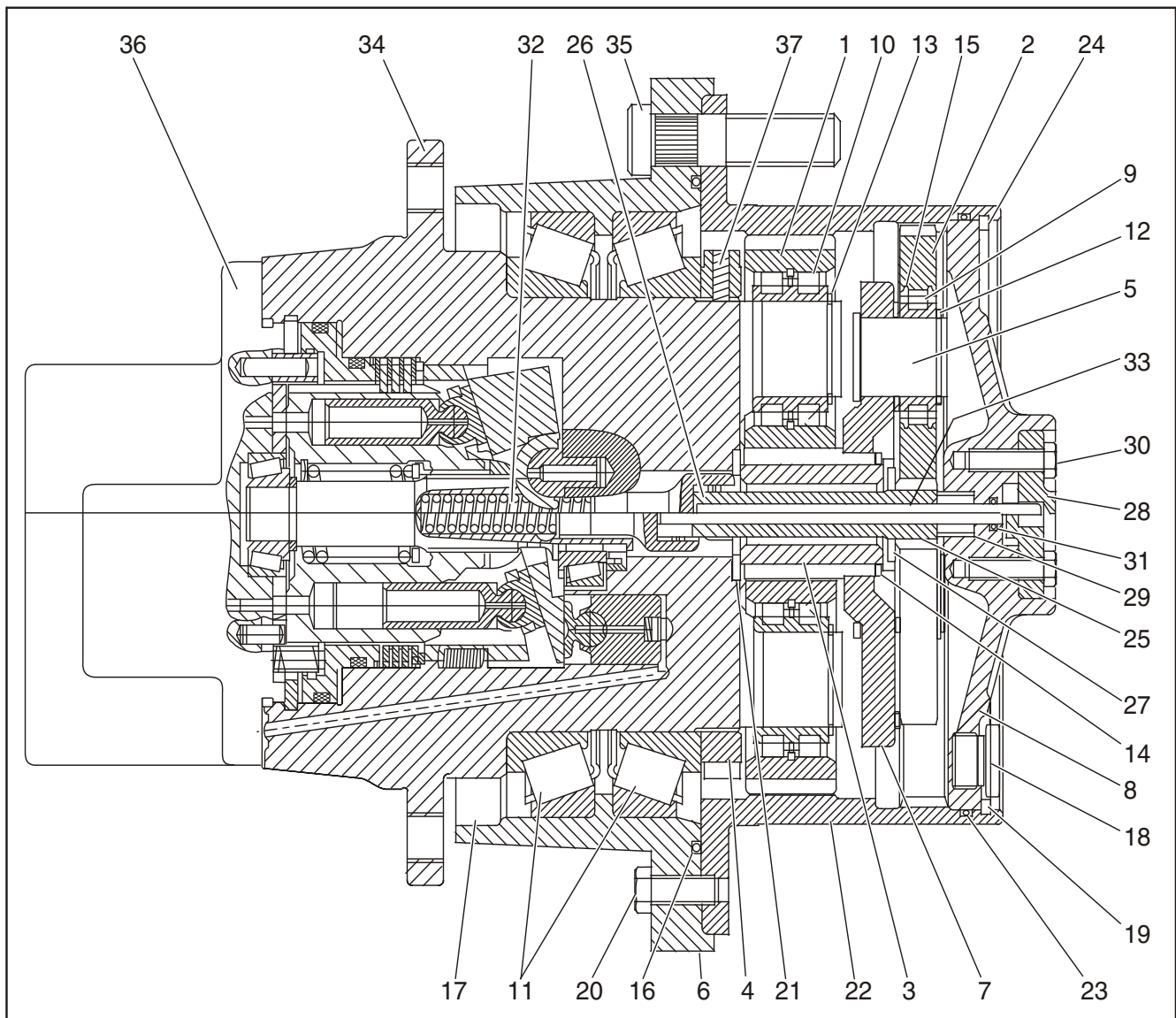

Figure 3-3. Integrated Torque/Drive Hub

Table 3-2. Torque/Drive Hub Specs

Gearbox	
Maximum Output Speed	30.25 rpm
Maximum Output Torque	4556.5 lb-ft (6177.7 Nm)
Brake	
Static Brake Torque	88 lb-ft (119.3 Nm)
Release Pressure	174 psi (12 bars)
Motor	
Maximum Displacement	28 CCM
Minimum Displacement	14.2 CCM
Switching Pressure	145 psi min - (1450 psi) max

SECTION 3 - CHASSIS, PLATFORM & SCISSOR ARMS



- | | | | |
|--------------------|----------------------------|------------------------|-------------------------|
| 1. Planet Gear | 11. Tapered Roller Bearing | 21. Thrust Washer | 31. O-Ring |
| 2. Planet Gear | 12. Retaining Ring | 22. Gear, Ring Options | 32. Spring |
| 3. Sun Gear | 13. Retaining Ring | 23. O-Ring | 33. Shift Rod |
| 4. Shaft Nut | 14. Retaining Ring | 24. Retaining Ring | 34. Brake Housing |
| 5. Planet Pin | 15. Support Disk | 25. Sun Gear Shaft | 35. Wheel Stud |
| 6. Support Ring | 16. O-Ring | 26. Input Shaft | 36. Hydraulic Motor |
| 7. Planet Carrier | 17. Shaft Seal | 27. Thrust Washer | 37. Spring Sleeve Dowel |
| 8. Cover | 18. Screw Plug | 28. Cover | |
| 9. Roller Bearing | 19. Seal Ring | 29. Sleeve | |
| 10. Roller Bearing | 20. Bolt | 30. Bolt | |

Figure 3-4. Drive Motor/Hub Assembly

Table 3-3. Gearbox Maintenance Schedule

After 150 motor operating hours	- First oil change
Weekly:	- Inspect visually - Check for unusual noise - Check oil level
Monthly:	- Check the tightness of all screws and bolts
Semi-annually:	- Check oil quality
Annually: (or after 1500 motor operating hours, whichever comes first)	- Change oil

Disconnect Mechanism

The disconnect mechanism on the torque/drive hub allows the machine to be towed. When activated, the mechanism disconnects the gear drive and motor.

DISENGAGING PROCEDURE:

NOTICE

PRIOR TO DISENGAGING, THE MACHINE MUST BE ON LEVEL GROUND AND COMPLETELY SECURED FROM ANY MOVEMENT. ENSURE AREA SURROUNDING THE DISCONNECT IS CLEANED PRIOR TO OPERATION. MAKE SURE DIRT OR OTHER CONTAMINANTS DO NOT ENTER THE GEAR DRIVE.

WARNING

CHECK GEAR DRIVE TEMPERATURE PRIOR TO HANDLING. GEAR DRIVE MAY BE HOT AND CAUSE INJURY IF RECENTLY OPERATED.

For numbers in parenthesis, refer to Figure 3-4., Drive Motor/Hub Assembly.

1. Remove the 2 Bolts (30) from the Cover (28).
2. Remove the Cover.
3. Rotate Cover to show inside diameter.
4. Press Cover sufficiently against the Shift Rod (33) to insert the 2 Bolts at least 2-3 threads into the Cover. The Shift Rod is now subjected to the Spring (32) force.
5. Install the 2 Bolts (30) and tighten until they are flush with the Cover (28) with a torque wrench to 6.3 lb-ft (8.5 Nm).

The Sun Gear Shaft (25) and Input Shaft (26) are now disconnected and the machine is ready to be towed.

NOTICE

THE MAXIMUM GEAR DRIVE TOWING SPEED OF 72 RPM MUST NOT BE EXCEEDED. ENGAGE GEAR DRIVE OR SECURE MACHINE WHEN MACHINE IS SEPARATED FROM THE TOWING VEHICLE.

ENGAGING PROCEDURE:

NOTICE

PRIOR TO ENGAGING, THE MACHINE HAS TO BE ON LEVEL GROUND AND COMPLETELY SECURED FROM ANY MOVEMENT. ENSURE AREA SURROUNDING THE DISCONNECT IS CLEANED PRIOR TO OPERATION. MAKE SURE DIRT OR OTHER CONTAMINANTS DO NOT ENTER THE GEAR DRIVE.

WARNING

CHECK GEAR DRIVE TEMPERATURE PRIOR TO HANDLING. GEAR DRIVE MAY BE HOT AND CAUSE INJURY IF RECENTLY OPERATED.

WARNING

THE COVER (28) IS UNDER SPRING FORCE.

For numbers in parenthesis, refer to Figure 3-4., Drive Motor/Hub Assembly.

1. Remove the 2 Bolts (30) from the Cover (28) evenly.
2. Remove the Cover.
3. Rotate the Cover 180° and assemble.
4. Tighten 2 Bolts (30) with a torque wrench to 6.3 lb-ft (8.5 Nm).
5. Slightly pull the machine with the towing vehicle to allow the spline of the Sun Gear Shaft (25) to engage with the spline of the Input Shaft (26).

WARNING

DO NOT OPERATE THE MOTOR TO OBTAIN ENGAGEMENT.

6. Check again that all bolts are tight and that all components are returned to their original position.

The gear drive should now be reengaged and the machine can be disconnected from the towing vehicle.

Gearbox Disassembly

For numbers in parenthesis, refer to Figure 3-4., Drive Motor/Hub Assembly.

1. Remove Screw Plugs (18, 19) and drain oil into appropriate container.



2. Remove Snap Ring (24).



3. Remove the assembled Cover (8) with Shift Rod (33) and O-ring (23).



4. Remove Sun Gear Shaft (25).



5. Remove complete 1st planet stage.



6. Remove ring gear fastening Bolts (20), Ring Gear (22), and O-ring (16)..



7. Remove Snap Rings (13).



10. Drilling Hole Sketch

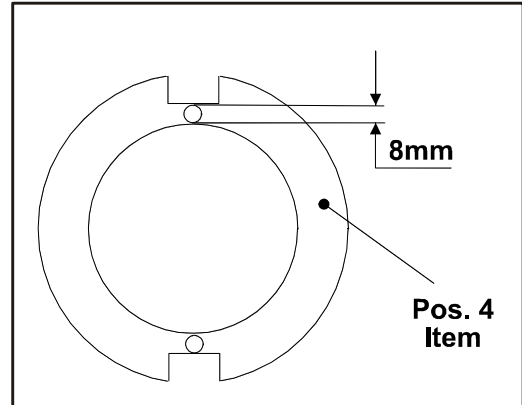

8. Pull out Plane Gears (1).



11. Split the Shaft Nut (4) in the area of the two drill holes by means of a chisel, and remove from Spindle (34).



9. Drill 2 holes into Shaft Nut (4) at 180° spacing according to Drilling Hole Sketch (step 10).



NOTICE

DO NOT DAMAGE THE BEARING CAGE OF THE BEARING (11). DO NOT TURN THE SHAFT NUT; POSSIBILITY OF SPINDLE THREAD DAMAGE.

NOTICE

DO NOT DAMAGE THE BEARING CAGE OF TAPERED ROLLER BEARING. CAREFULLY REMOVE METAL CHIPS.

SECTION 3 - CHASSIS, PLATFORM & SCISSOR ARMS

12. Remove the Support Ring (6) from the Spindle (34). Components stay in Supporting Ring (6).



15. Repair deformed threads on the Spindle (34) in the area of the ball detent with a thread file of 1.5mm pitch.

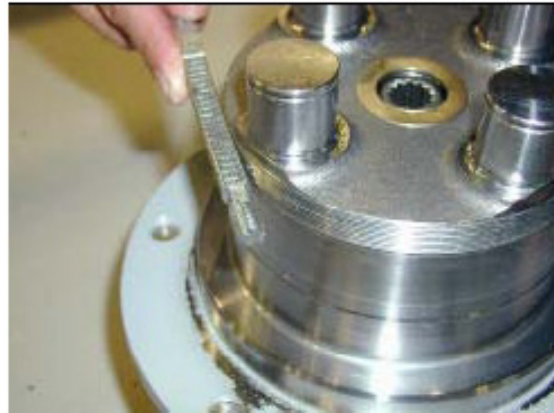

13. Remove Radial Shaft Seal Ring (17).

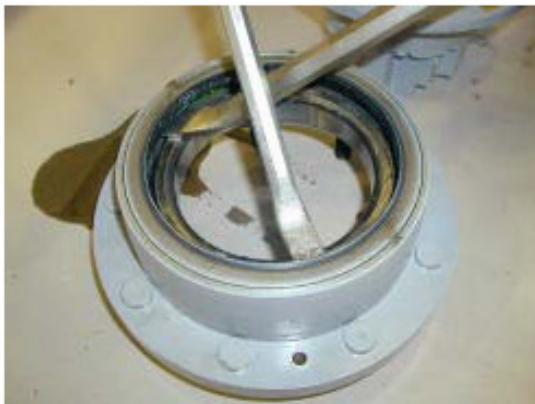

Gearbox Assembly

NOTE: Clean all parts before assembling the gearbox.

1. Make sure during assembly of the preassembled planet gears that the larger radius on the bearing bore is oriented towards the planet carrier.

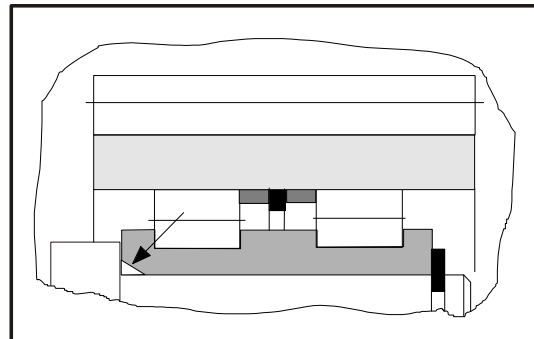

14. Disassembly of planet gears and sun gear (1st stage).
 - a. Remove Snap Rings (12) and pull out Planet Gears (2).
 - b. Remove Support Disks (15).
 - c. Remove Snap Ring (14) and lift off Planet Carrier (7).



2. Assembly of planet gears and sun gear (1st Stage).
 - a. Fasten the Sun Gear (3) with a new Snap Ring (14) to the Planet Carrier (7).
 - b. Mount the Support Disks (15) and the planet gears with Bearing Assembly (2, 10) heated to approximately 189.5° F (70° C) onto the planet bolts.

- c. Secure the gears with new Snap Rings (12).



5. Insert the bottom part of the double Tapered Roller Bearing (11).



NOTE: Heat Supporting Ring (6) to approximately 189.5° F (70° C) in a heating furnace.

3. Insert outer rings into heated Supporting Ring (6). (check for proper axial seat)

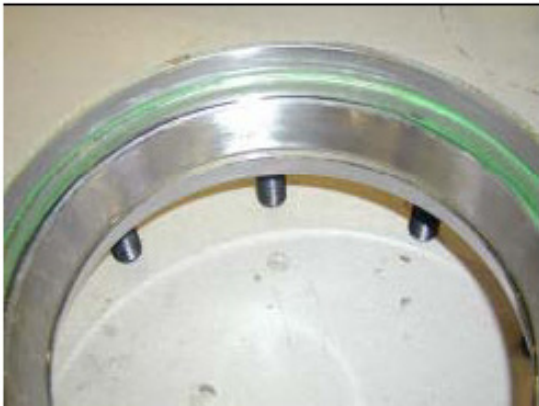

6. Insert radial Shaft Seal Ring (17) into Supporting Ring (6) and fill mounting space between sealing lips with roller bearing grease.

NOTE: Observe correct mounting position of sealing lip prior to installing the seal ring.



4. Coat bore in Supporting Ring (6) with Loctite® 573 for Radial Shaft Seal Ring (17).



7. Install preassembled supporting ring onto Spindle (34).



SECTION 3 - CHASSIS, PLATFORM & SCISSOR ARMS

8. Heat upper ring with roller cage of double Tapered Roller Bearing (11) to approximately 189.5° F (70° C) and mount onto Spindle (34). Allow cooling time of approximately 15 minutes before continuing assembly.



9. De-grease threads of Spindle (34) and Shaft Nut (4). Then evenly apply coat of Loctite® 270 to Shaft Nut (4) threads.



10. Rotate the supporting ring repeatedly in one direction only when setting the tapered roller bearing.
 - a. Tighten Shaft Nut (4) by using an adequate device with a tightening torque of 627 lb-ft (850 Nm).

- b. The Loctite® setting time equals 24 hours at ambient temperature of 68° F (20° C).



11. After proper bearing setting is completed, hammer ball with suitable punch, 1.1 - 1.3mm into the spindle thread. Retain ball in position with expanding plug.



12. Insert a new greased O-Ring (16) into the o-ring groove of the Supporting Ring (6).



SECTION 3 - CHASSIS, PLATFORM & SCISSOR ARMS

13. Assembly of planet gear (Main Stage):
 - a. Mount the planet gears with Bearing Assembly (1, 10), heated to approximately 189.5° F (70° C), onto the planet bolts of the Spindle (34) and secure the gears with new Snap Rings (13).



14. Install the Ring Gear (22).

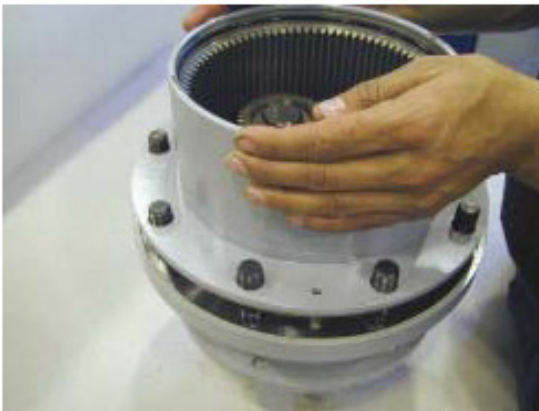

15. Install the ring gear hex head bolts. Tighten bolts to proper torque of 15.5 lb-ft (21 Nm).

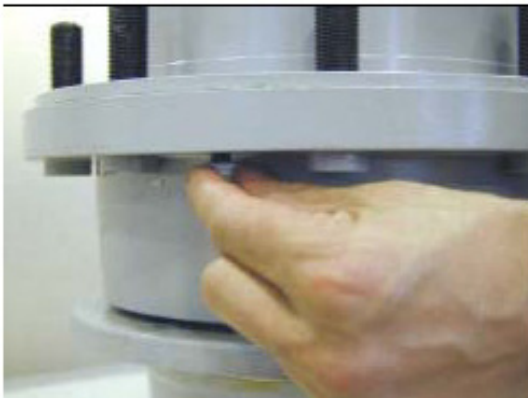

16. Install completely pre-assembled 1st planet stage into the gear drive.



17. Install Sun Gear Shaft (25).



18. Check axial clearance:

- a. Determine clearance between contact face of Sun Gear (3) and Sun Gear Shaft (25). (Recommended clearance 1.0 -1.5mm)

19. Carefully insert a new greased O-ring (23) into the o-ring groove of Ring Gear (22).



SECTION 3 - CHASSIS, PLATFORM & SCISSOR ARMS

20. Insert Shift Rod (33) into preassembled Cover (8).



23. Install Plugs (18) with new Seal Rings (19) into Cover (8).



21. Install preassembled Cover (8) into Ring Gear (22).



22. Install Snap Ring (24).



NOTE: Prior to operating, fill the drive with new oil.

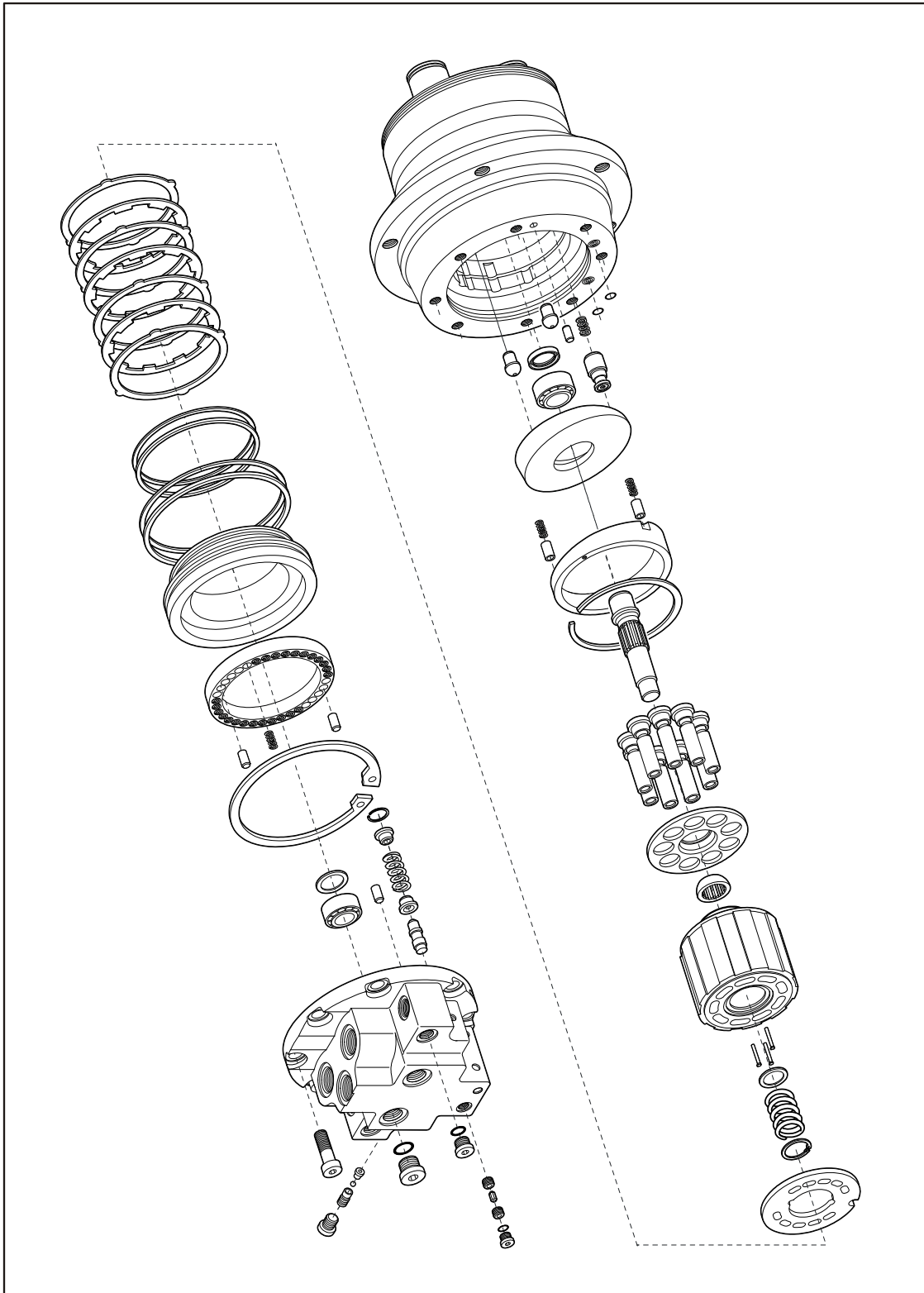
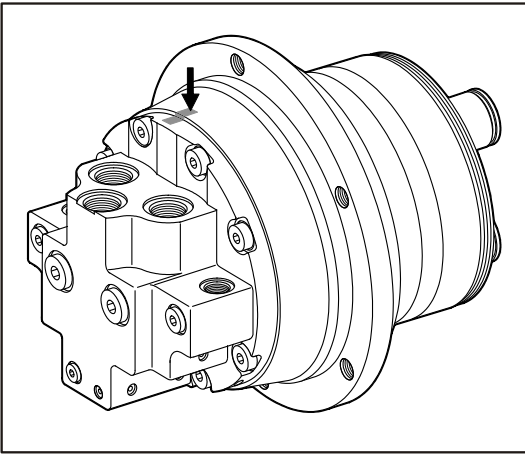

Figure 3-5. Drive Hub Assembly

Motor Disassembly

1. Mark port plate to the supporting axle.



2. Remove port plate.

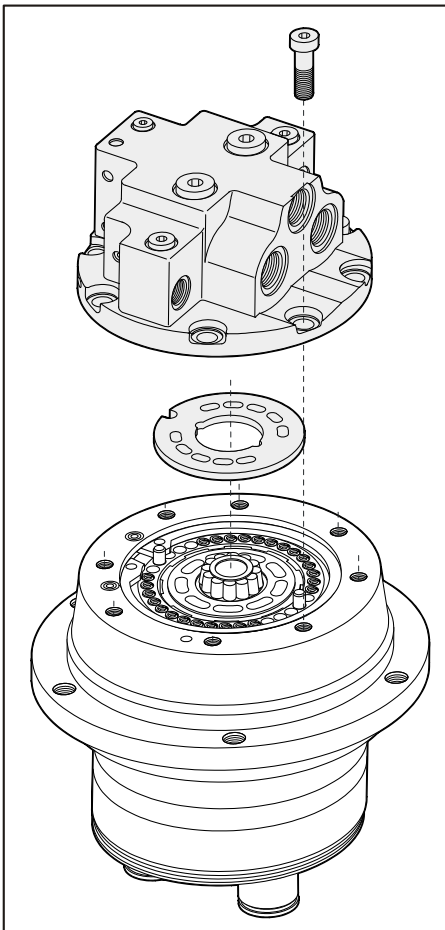

3. Disassemble guide ring:
 - a. Seal Ring (1)
 - b. Pressure Springs (2) (quantity = 26)
 - c. Guide Ring (3)

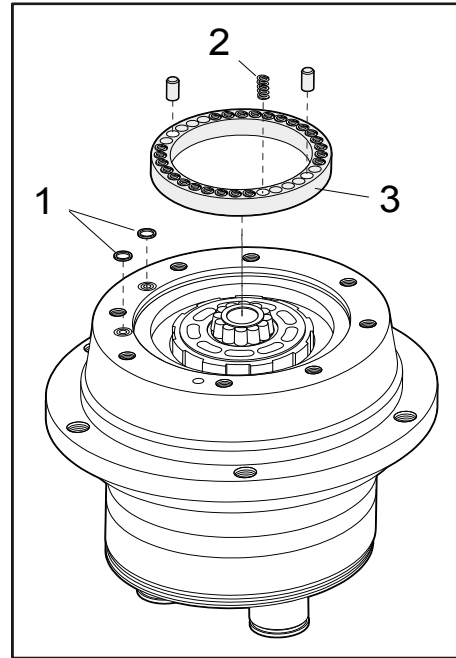

4. Disassemble retaining ring.

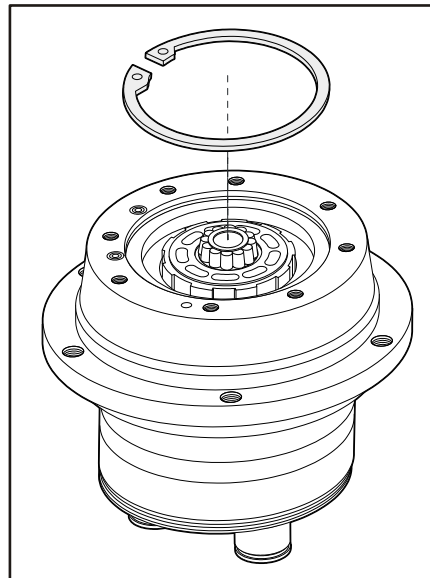

5. Disassemble bearing with synchronizing plate.

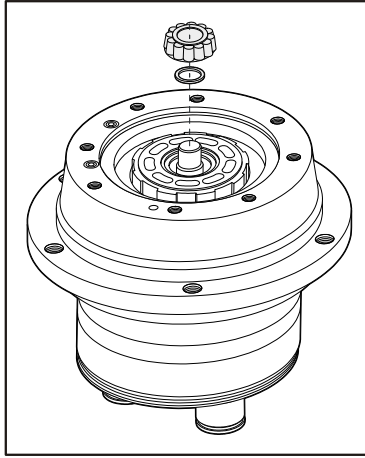

8. Disassemble lamination kit.

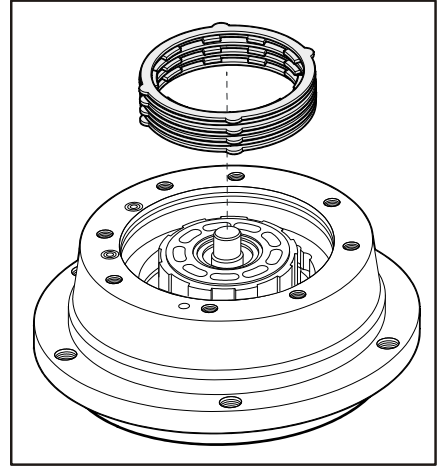

6. Remove pressure ring with extractor.

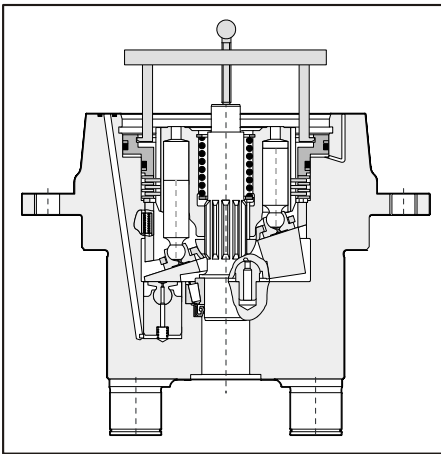

9. Disassemble Seeger snap ring.

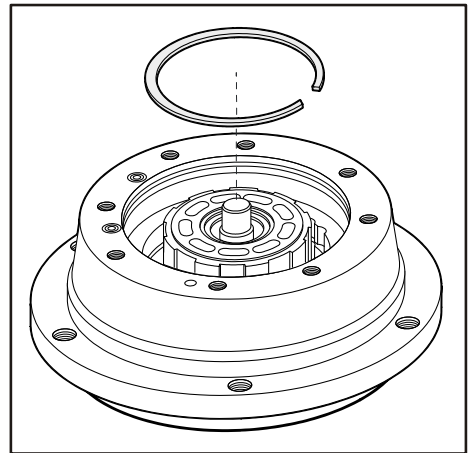

7. Remove pressure ring.

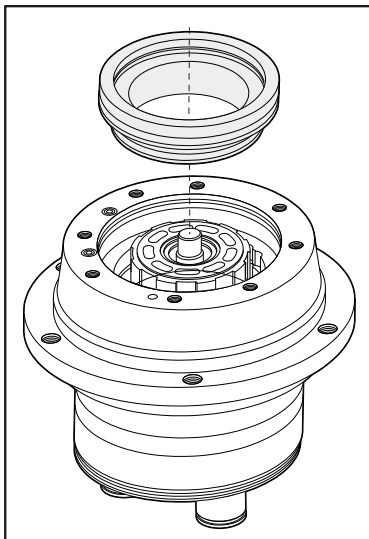

10. Disassemble cradle stop with 2 screws, M4 x 75mm.

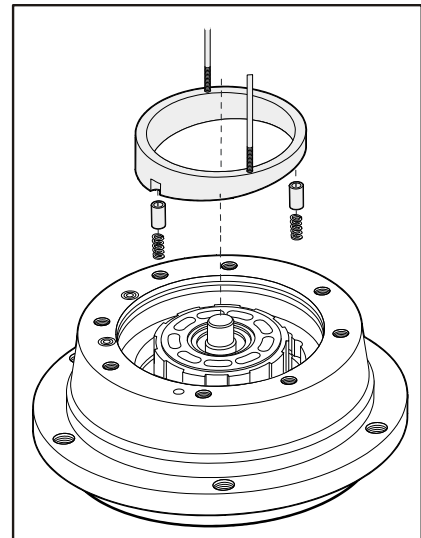

SECTION 3 - CHASSIS, PLATFORM & SCISSOR ARMS

11. Disassemble rotary group completely with cradle.

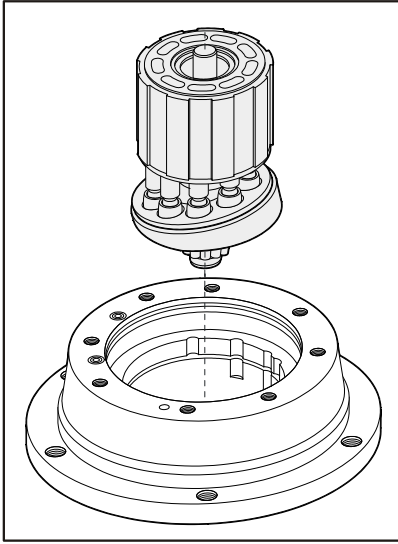

14. Disassemble shaft seal ring.

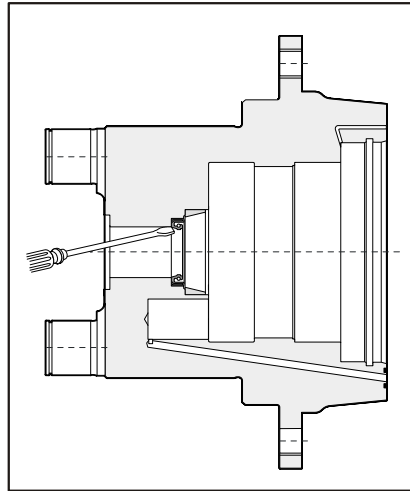

12. Disassemble control piston with spring.

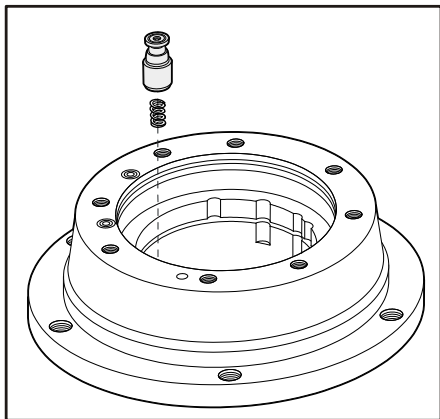

15. Insert disc. Pull off bearing ring with device. Remove disc.

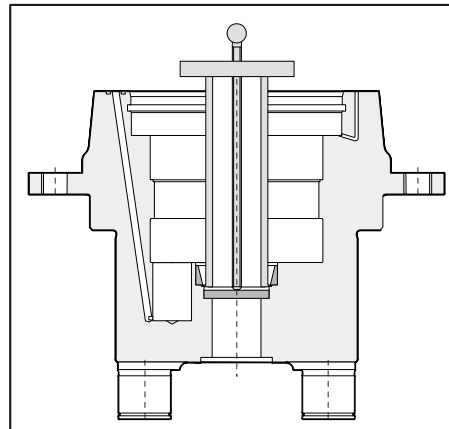

13. Pull out swivel balls.

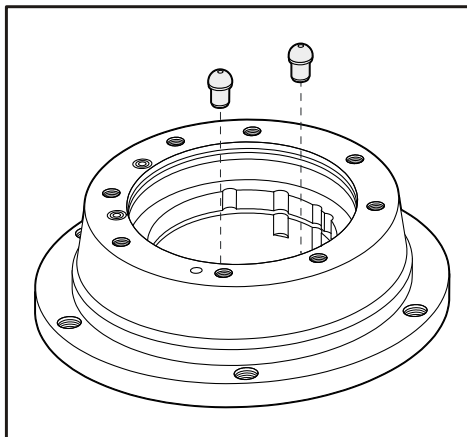

16. Disassemble bearing ring from port plate.

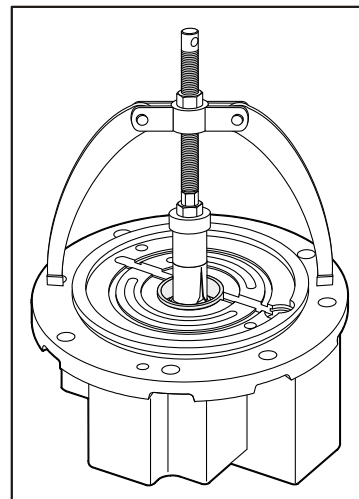

17. Remove bearing ring (1). Disassemble spool (2).

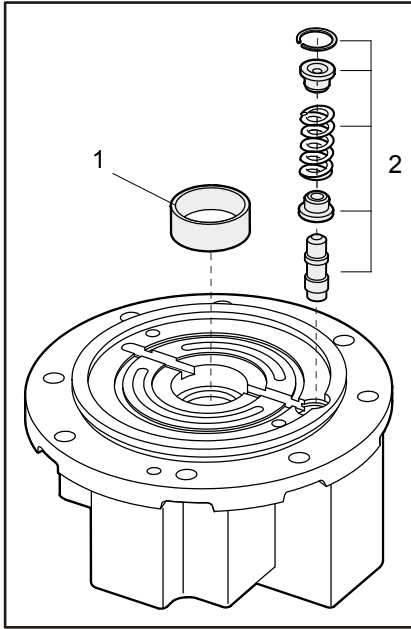

19. Check that there are no scratches or metal deposits on sliding surface (1), and there is no axial play (2), (Otherwise: Pistons must be replaced in sets).

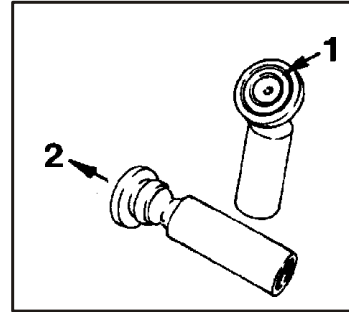

20. Check cylinder bores, splines.

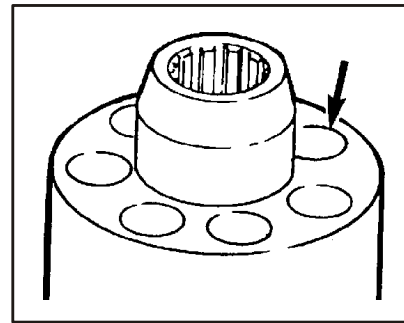

18. Disassemble shuttle valve (1). Disassemble throttle screw with throttle pin (2).

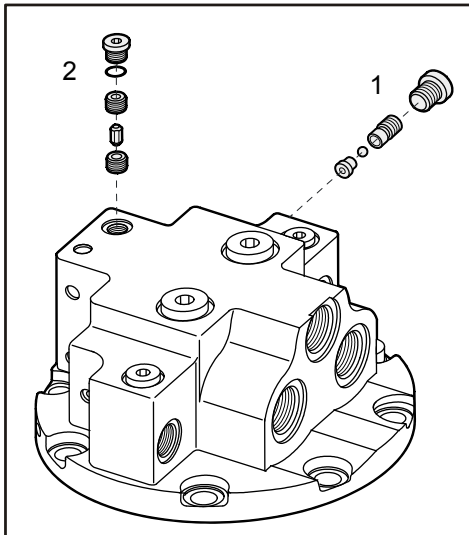

21. Check that cylinder track is free of scratches, there are no traces of wear and no embedded foreign particles. Make sure there are no scratches on the valve plate. (Replace ONLY in sets).

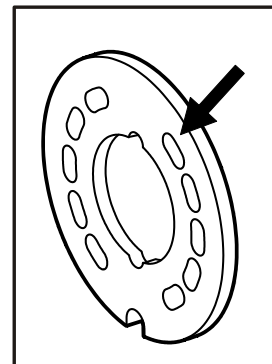

SECTION 3 - CHASSIS, PLATFORM & SCISSOR ARMS

22. Check splines (1) for damage or fretting; running surfaces (2); groove cut by shaft seal (3).

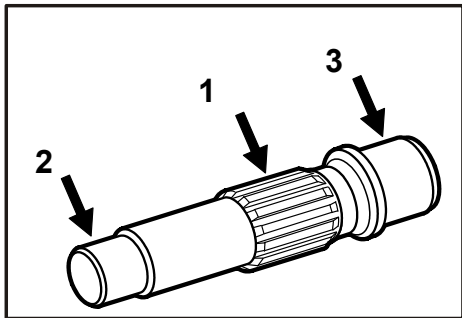

23. Check that sliding surface is free of grooves (1); cups are free of grooves and there are no pittings (2).

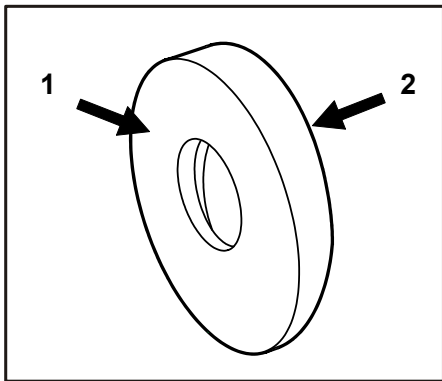

24. Make sure the seat of the shaft seal in the case has no damage.

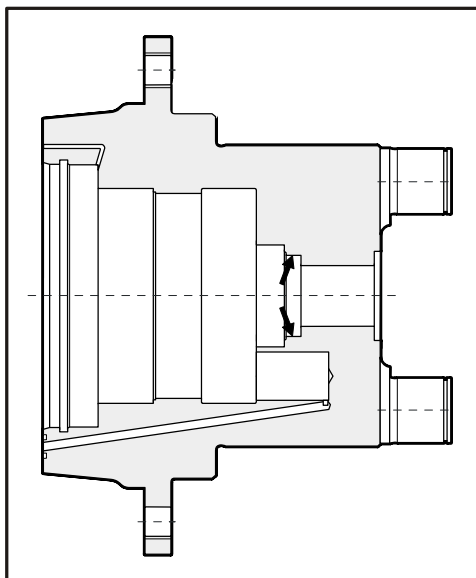

25. Make sure the sealing surfaces are damage free.

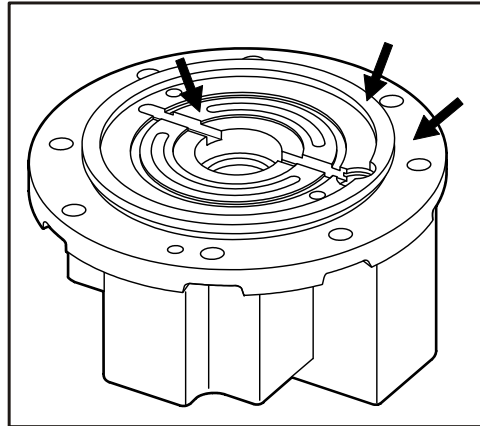

26. Press bearing ring in port plate (with tool).

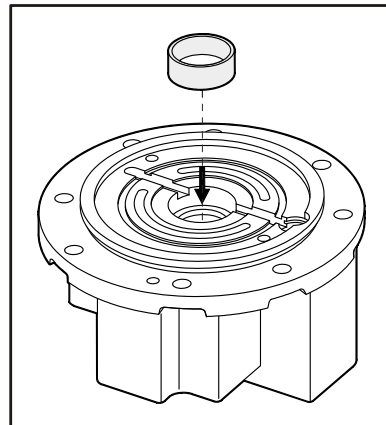

27. Press bearing ring in supporting axle (with tool).

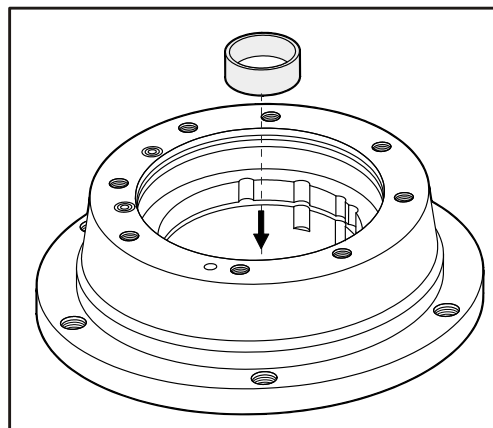

28. Press bearing on drive shaft.

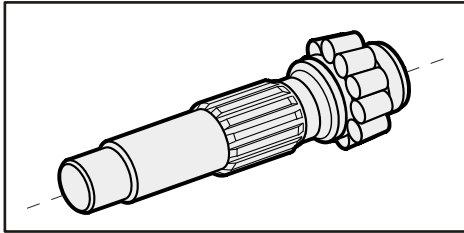

29. Install shaft in supporting axle (1). Place in simulation ring (2). Mount bearing with port plate, fix with 2 screws (3)

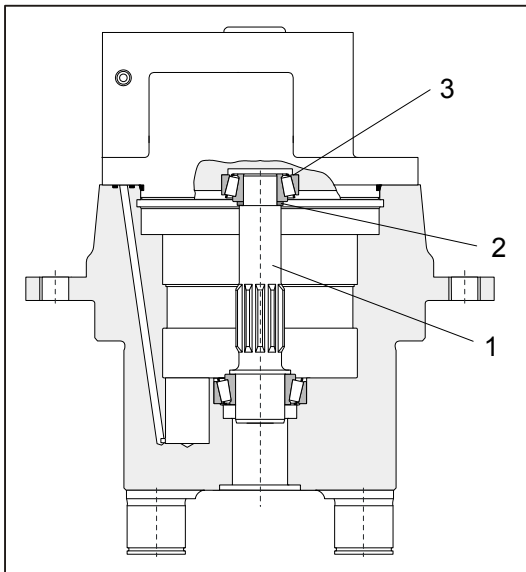

30. Attach a measuring device. Ascertain tolerance. Grip shaft with Seeger ring pincers and move up and down. [Simulation ring 1mm + tolerance + (bearing pretension 0.05 - 0.08) is resulting in thickness of the synchronizing disc]. Grind synchronizing disc to dimension.

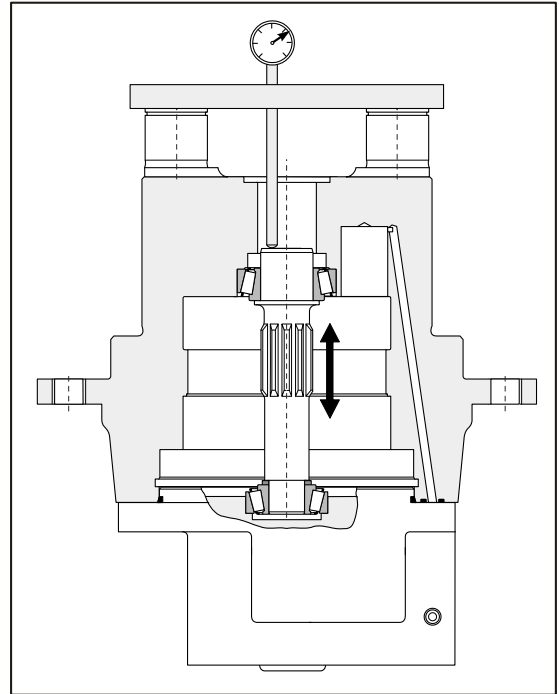

Motor Assembly

1. Press in swivel balls (with tool) (1). Insert shaft seal ring (with tool) (2). Insert control piston with spring (3).

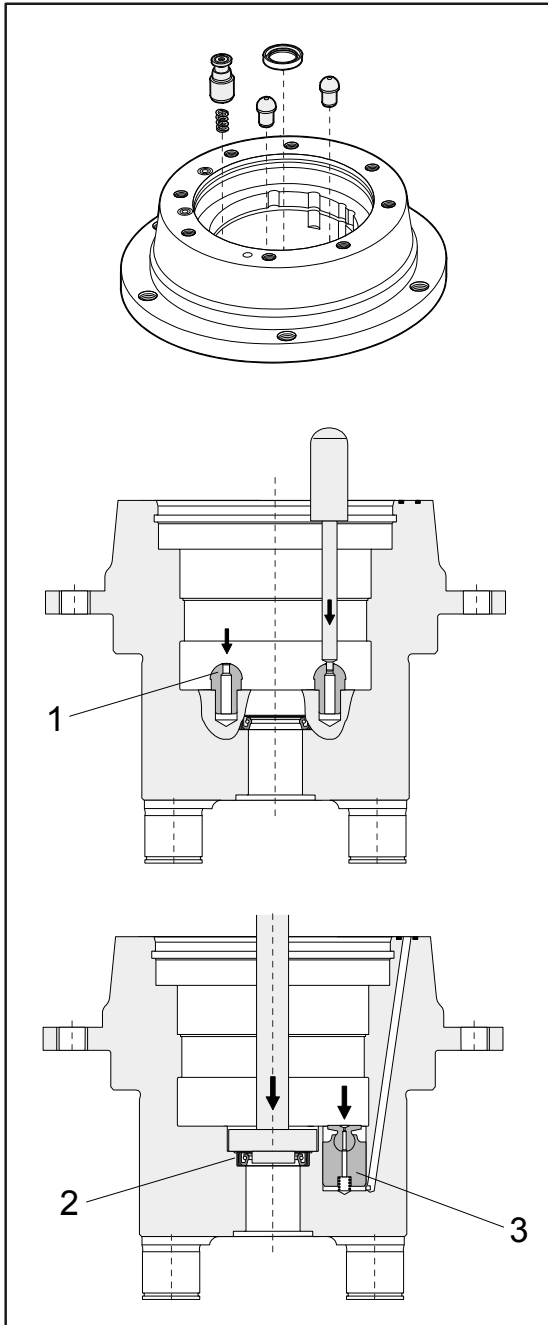

2. Install rotary group with cradle. Observe installation position of swivel balls.

NOTE: Slightly grease swivel balls.

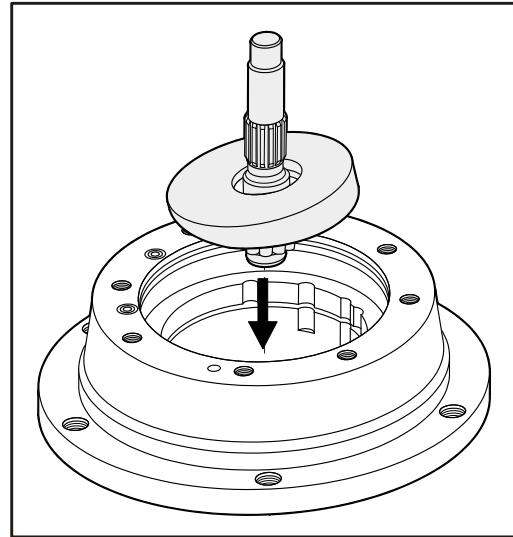

3. Mount sleeve and pressure ring in cradle stop. Insert cradle stop.

NOTE: Stick with grease.

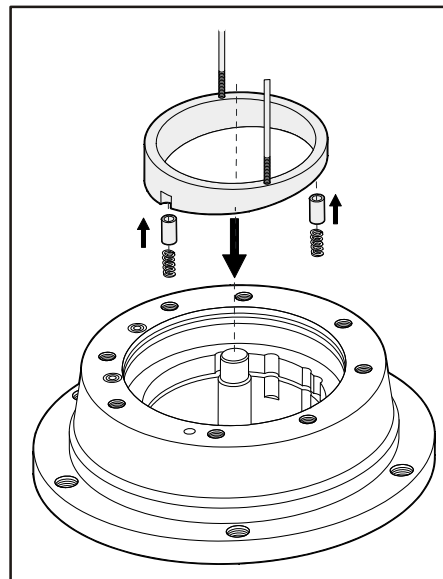

4. Mount Seeger snap ring. Opening of snap ring must be on the opposite side of the control piston.

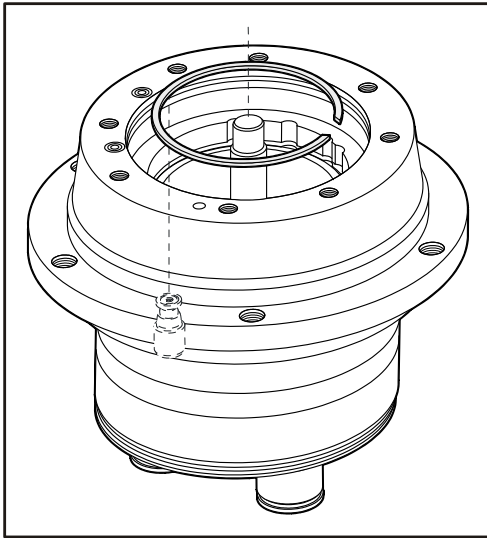

6. Assemble piston with retaining plate. Oil piston and slipper pad.

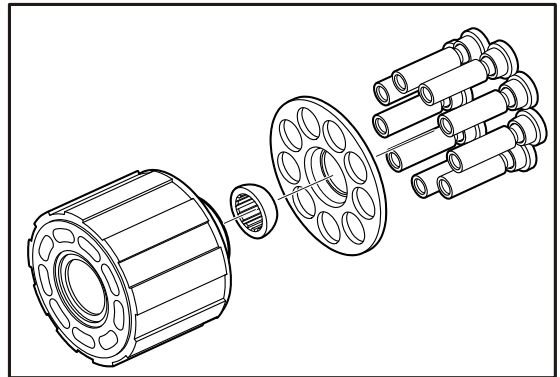

5. Fit pressure pins using an assembly aid. Pre-tension the spring using a suitable device.

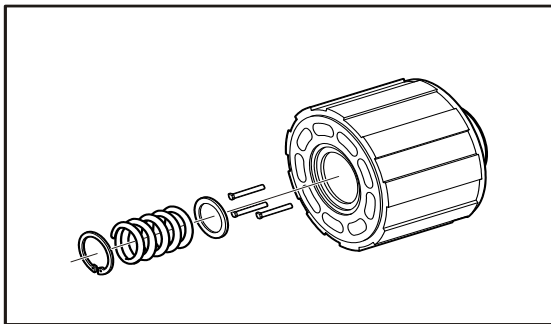

7. Assembly aid: Hold the pistons by using an o-ring.

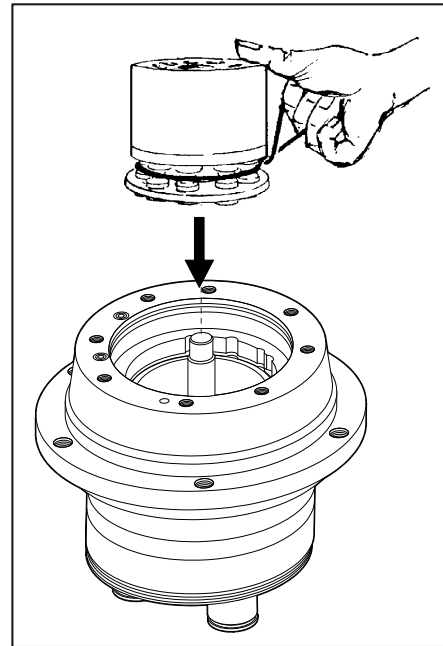

SECTION 3 - CHASSIS, PLATFORM & SCISSOR ARMS

8. Install laminations in correct order.

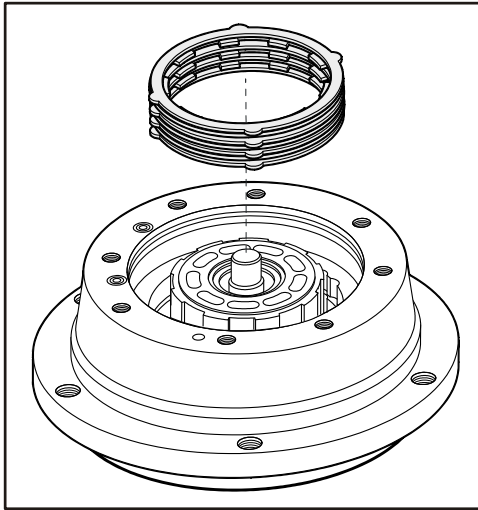

10. Grease seal rings, install in supporting axle.

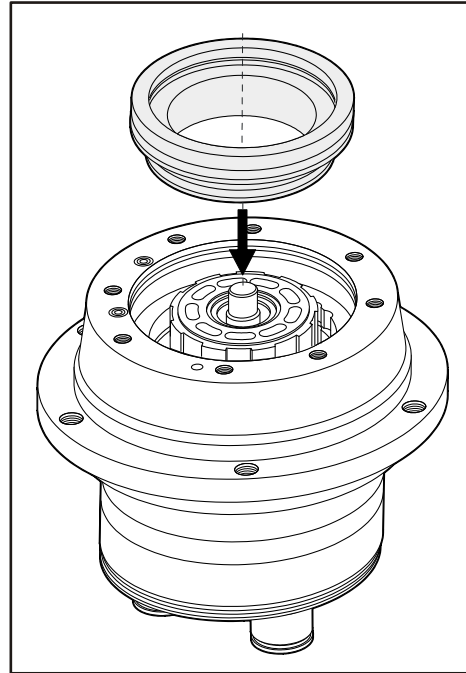

9. Mount support ring (1) and quad ring (2) in pressure ring. Be careful not to excessively extend the rings.

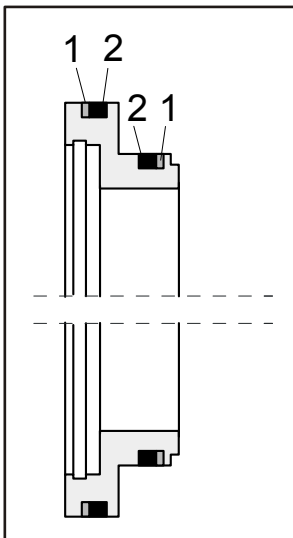

11. Mount retaining ring.

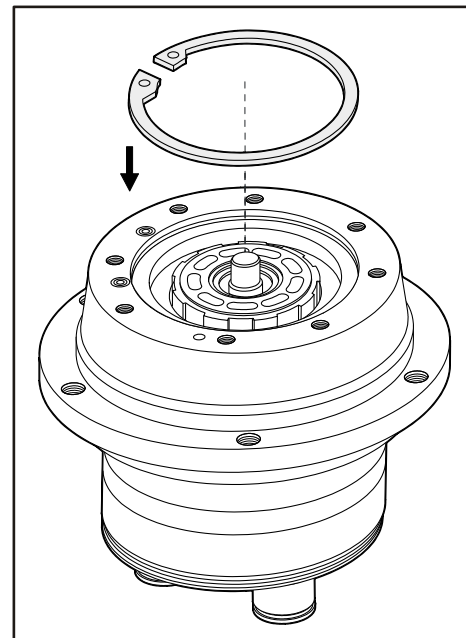

12. Mount seal rings (1). Insert and line-up guide ring.

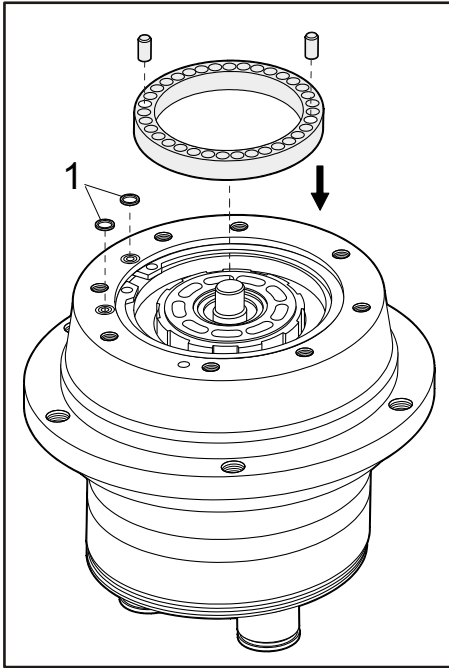

14. Mount synchronizing disc (1) and bearing (2).

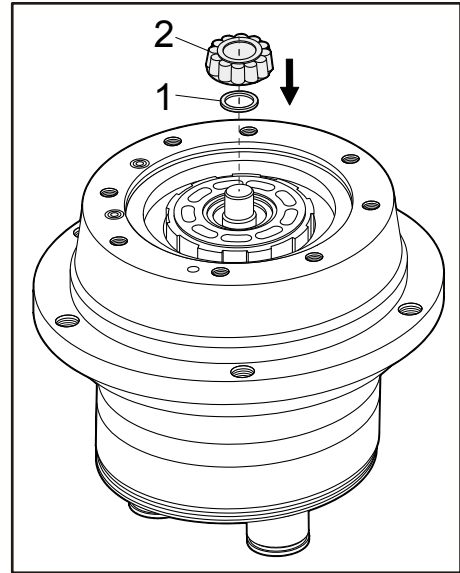

13. Align the two holes for fixation cylinder pin - port plate (item 2).

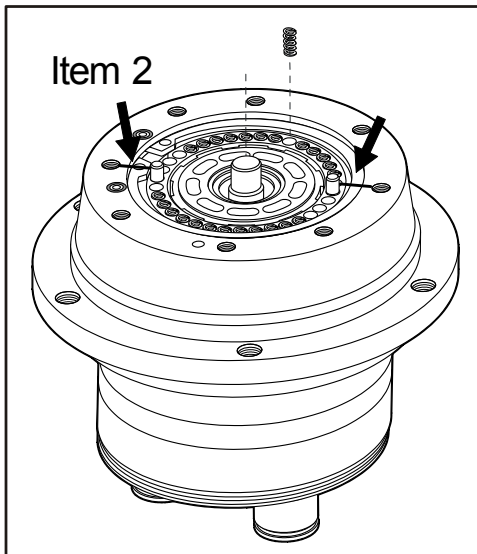

15. Mount bearing ring with device. Mount spool. Mount fixation pin.

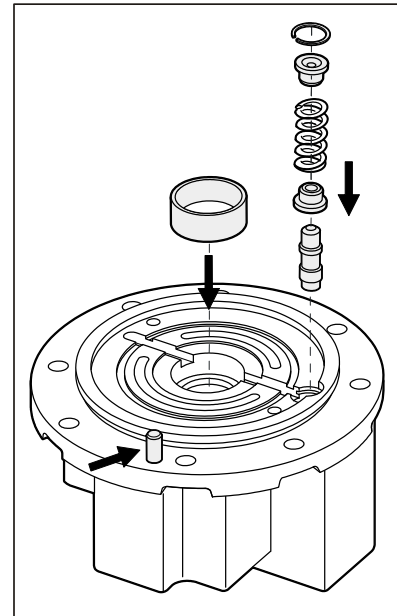

SECTION 3 - CHASSIS, PLATFORM & SCISSOR ARMS

16. Fix control plate with grease at port plate.

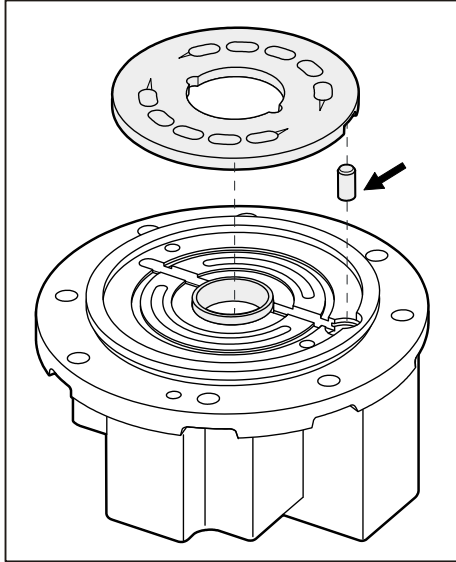

18. Mount and screw port plate on supporting axle.

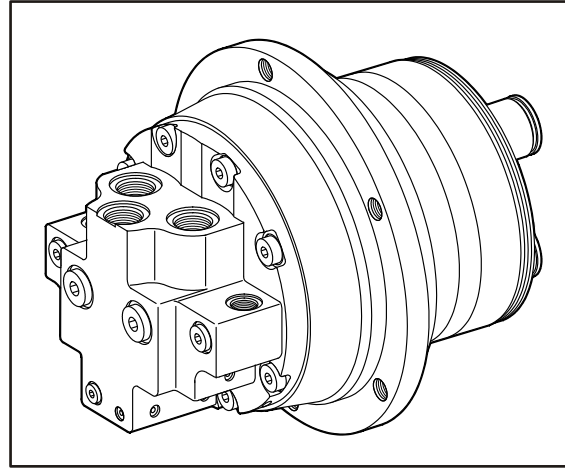

17. Fill case with oil.

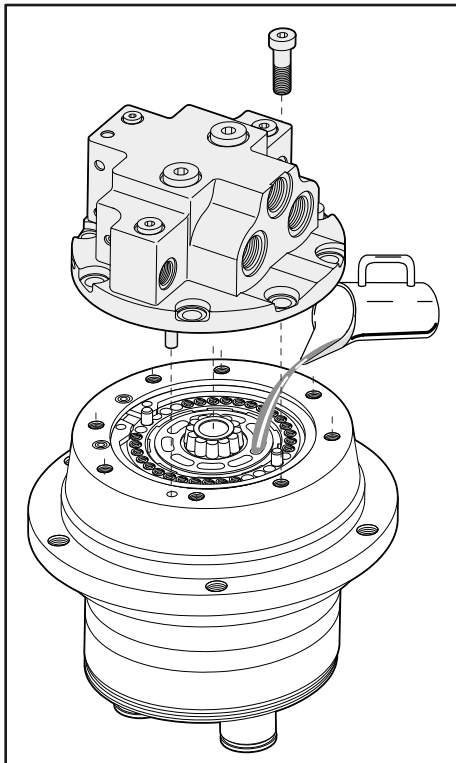

3.4 DRIVE HUB (FAIRFIELD)

Roll and Leak Testing

Always roll and leak test Drive-Hubs after assembly to make sure that the unit's gears and sealants are working properly. The following information briefly outlines what to look for when performing these tests.

THE ROLL TEST

The purpose of a roll test is to determine if the unit's gears are rotating freely and properly. You should be able to rotate the gears in your unit by applying a constant force to the roll checker. If you feel more drag in the gears only at certain points, then the gears are not rolling freely and you should examine them for improper installation or defects. Some gear packages roll with more difficulty than others. Do not be concerned if the gears in your unit seem to roll hard as long as they roll with consistency.

THE LEAK TEST

The purpose of a leak test is to make sure the unit is air tight. You can tell if your unit has a leak if the pressure gauge reading on your air checker starts to fall once you have pressurized the unit. Leaks will most likely occur at the main seal or wherever o-rings or gaskets are located. Usually you can detect the exact location of a leak by brushing a soap and water solution around the main seal and where o-rings or gaskets meet the exterior of the unit, then checking for air bubbles. If you detect a leak in a seal, o-ring, or gasket, replace the part immediately.

Tightening and Torquing Bolts

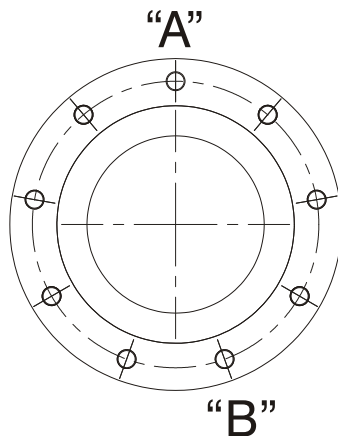

If you use an air impact wrench to tighten bolts, take extreme care to ensure that you do NOT tighten the bolts beyond their indicated torque specification. Never use an impact wrench to tighten shoulder bolts. Always tighten all shoulder bolts by hand.

The following steps describe the proper procedure for tightening and torquing bolts or socket head **cap screws** in a bolt circle.

1. Tighten (but do not torque) bolt "A" until snug.
2. Go to the opposite side of the bolt circle and tighten bolt "B" until equally snug.
3. Continue around the bolt circle and tighten the remaining bolts.
4. Now use a torque wrench to apply the specified torque to bolt "A".
5. Continue around the bolt circle and apply an equal torque to the remaining bolts.

Oil Information

1. TYPE – EP90
On normal applications, use EP90. On applications where the lubricant must meet special requirements, the O.E.M. should be able to recommend a suitable substitute.
 2. OIL TEMPERATURE
Continuous – 160°F [70°C] Intermittent – 200°F [95°C]
 3. OIL CHANGE
Initial – After 50 hours or 50,000 revolutions of operation. Subsequent – After 1000 hours or (1) year, whichever comes first.
- NOTE:** Higher temperatures make it necessary to change oil more frequently.
4. OIL FILL LEVEL AND VOLUME
Unit mounted horizontal – half full
Approximate volume - 17 oz. (0.5 ltr)
 5. REAR BRAKES
Rear brakes require 2.7 oz. (0.08 ltr) of DTE 13M hydraulic fluid each to function properly.

SECTION 3 - CHASSIS, PLATFORM & SCISSOR ARMS

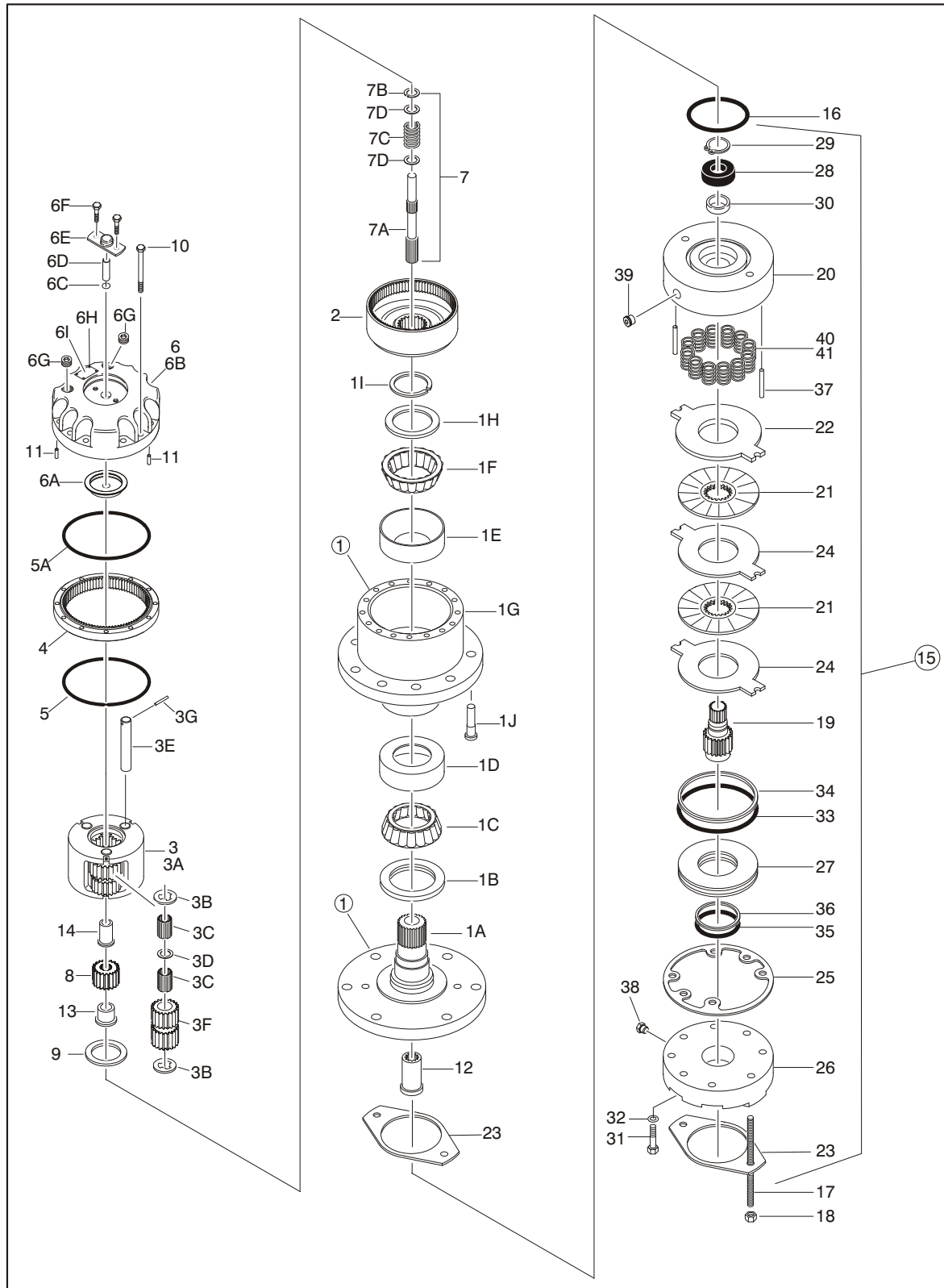

Figure 3-6. Drive Hub

SECTION 3 - CHASSIS, PLATFORM & SCISSOR ARMS

NOTE: Refer to Figure 3-6., Drive Hub.

Table 3-4. Drive Hub Part Description

Item #	Description
1	Spindle/Housing Assembly
1A	Spindle
1B	Seal
1C	Bearing Cone
1D	Bearing Cup
1E	Bearing Cup
1F	Bearing Cone
1G	Housing/Ring Gear
1H	Thrust Washer
1I	Retaining Ring
1J	Wheel Stud
2	Internal Gear
3	Carrier Assembly
3A	Carrier
3B	Retaining Ring
3C	Needle Bearing
3D	Thrust Washer
3E	Planet Shaft
3F	Planet Gear
3G	Rollpin
4	Ring Gear
5	O-Ring
5A	O-Ring
6	Cover Assembly
6A	Thrust Spacer
6B	Cover Plate
6C	O-Ring
6D	Disconnect Rod
6E	Disengage Cap
6F	Bolt 1/2"-20NC x 1/2"
6G	Pipe Plug
6H	Rivet
6I	ID Plate
7	Input Shaft Assembly
7A	Shaft
7B	Retaining Ring
7C	Spring
7D	Thrust Spacer
8	Sun Gear
9	Thrust Washer
10	Bolt

Table 3-4. Drive Hub Part Description

Item #	Description
11	Dowell Pin
12	Coupling
13	Input Spacer
14	Input Spacer
15	Brake Assembly
16	O-Ring
17	Threaded Rod
18	Nut 1/2"-13NC
BRAKE ASSEMBLY	
19	Shaft
20	Housing
21	Friction Plate
22	Pressure Plate
23	Gasket
24	Outer Plate
25	Gasket
26	Cylinder
27	Piston
28	Ball Bearing
29	Retaining Ring
30	Shaft Seal
31	Capscrew
32	Lockwasher
33	O-Ring
34	Back-up Ring
35	O-Ring
36	Back-up Ring
37	Dowel Pin
38	Plug
39	Plug
40	Spring Kit (Natural)
41	Spring Kit (Blue)

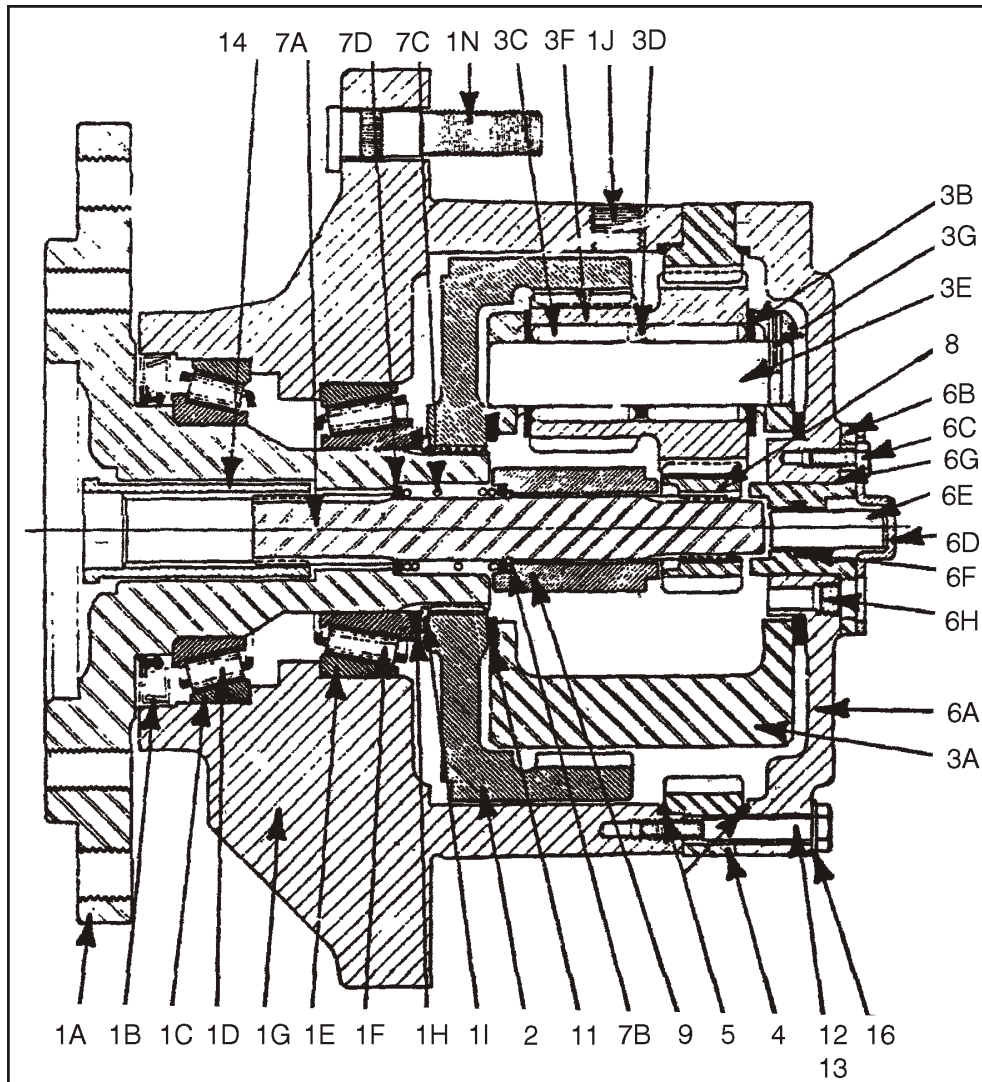

- | | | | |
|-----------------------------|-------------------------|-----------------------------|-------------------|
| 1. Hub-Spindle Sub-Assembly | 2. Internal Gear | 6 A. Cover | 7 C. Spring |
| 1 A. Spindle | 3. Carrier Sub-Assembly | 6 B. Cover Cap | 7 D. Spacer |
| 1 B. Seal | 3 A. Carrier Housing | 6 C. Bolt | 8. Input Gear |
| 1 C. Bearing Cup | 3 B. Thrust Washer | 6 D. Disconnect Cap | 9. Thrust Spacer |
| 1 D. Bearing Cone | 3 C. Needle Roller | 6 E. Disconnect Rod | 11. Thrust Spacer |
| 1 E. Bearing Cup | 3 D. Spacer | 6 F. O Ring | 12. Bolt |
| 1 F. Bearing Cone | 3 E. Planet Shaft | 6 G. O Ring | 13. Shoulder Bolt |
| 1 G. Hub | 3 F. Cluster Gear | 6 H. Pipe Plug | 14. Coupling |
| 1 H. Spacer | 3 G. Roll Pin | 6 I. ID Plate | 16. Flat Washer |
| 1 I. Retaining Ring | 4. Ring Gear | 7. Input Shaft Sub Assembly | |
| 1 J. Pipe Plug | 5. O Ring | 7 A. Seal | |
| 1 K. Stud | 6. Cover Sub-Assembly | 7 B. Retaining Ring | |

Figure 3-7. Drive Hub (Cross-Section)

Main Disassembly for Drive Hub

NOTE: Refer to Figure 3-7. for part location and listing.

1. Turn hub (1G) over onto its side. Remove coupling (14) from the wide end of spindle (1A).
2. Mark location of shoulder bolt holes on outside of ring gear and hub for easy re-alignment when rebuilding. Remove the four shoulder bolts (13) and twelve bolts (12) from cover (6).
3. Remove the sixteen flat washers (16) from cover (6).
4. Lift cover sub-assembly (6) off of ring gear (4), and set cover on table, interior side facing up.

⚠ CAUTION

CAUTION: BEWARE OF SHARP EDGES IN THE COUNTERBORE WHEN YOU REMOVE THE O-RING.

5. Remove o-ring (5) from the counterbore around the edge of cover (6A). Discard the o-ring.

NOTE: If o-ring is not in the cover counter-bore, it is in the ring gear counterbore. Remove it from the hub and discard it.

6. Remove thrust washer (11) from the counter-bore in top of carrier (3A).
7. Remove input gear (8) from the middle of carrier sub-assembly (3).
8. Lift ring gear (4) off of hub (1G).
9. Lift carrier sub-assembly (3) out of hub (1G).
10. Remove thrust spacer (9) from input shaft (7) in the middle of spindle (1A).
11. Lift input shaft sub-assembly (7) out of middle of spindle (1A), and stand input shaft (7A) on its splined end.

⚠ CAUTION

WEAR SAFETY GLASSES DURING THIS STEP, AND BE AWARE THAT SPRING AND SPACERS COMPRESSED BY RETAINING RING MAY POP SUDDENLY OFF SHAFT WHEN YOU REMOVE THE RETAINING RING.

12. Using retaining ring pliers, remove retaining ring (7B) from the groove on input shaft (7A).
13. Remove one spacer (7D), one spring (7C), and other spacer (7D) from input shaft (7A).
14. Remove thrust washer (11) from around spindle (1A).
15. Lift internal gear (2) out of hub (1G).

⚠ CAUTION

BEWARE OF SHARP EDGES IN COUNTERBORE WHEN YOU REMOVE THE O-RING.

16. Remove o-ring (5) from the counterbore in hub (1G). Discard the o-ring.
17. At this point the main disassembly for drive hub is complete.

Hub-Spindle Disassembly

NOTE: Start with large end of hub facing up, large end of spindle facing down.

⚠ CAUTION

WEAR SAFETY GLASSES DURING THIS STEP.

1. Remove retaining ring (1I) from around spindle (1A) in hub (1G).
2. Remove spacer (1H) from around spindle (1A) in hub (1G).
3. Set hub (1G), small end/spindle facing down, up on something that will support the hub's flange while it lifts hub up so spindle is not resting on anything. Carefully press or hammer spindle (1A) down and out of hub (1G).

NOTE: If seal (1B) and bearing cone (1D) come out of hub and rest on spindle, remove these parts from the spindle and set them aside. Discard the seal.

4. If seal and bearing cone did not come out of the small end of hub (1G) when spindle is pressed out of hub, remove seal (1B) and bearing cone (1D) from the small end of hub. Discard the seal.
5. Bearing cone (1F) should be lying loose in wide end of hub (1G). Remove bearing cone (1F) from inside hub.

NOTE: If you use a punch and hammer, make sure you do not strike the counterbore with the punch when you remove the bearing cup.

6. Remove bearing cup (1C) from the counterbore in the small end of hub (1G).

NOTE: If using a punch and hammer, make sure to not strike the counterbore with the punch when removing the bearing cup.

7. Turn hub (1G) over and lift it out of the flange-support. Remove bearing cup (1E) from the counterbore in the wide end of hub.

SECTION 3 - CHASSIS, PLATFORM & SCISSOR ARMS

- Turn hub (1G) over onto its small end. Remove two pipe plugs (1J) from the two pipe plug holes in the side of hub.

NOTE: If the unit does not have studs, skip this step:

- Press the nine studs (1N) out of the stud holes in hub (1G).
- At this point the hub-spindle disassembly is complete.

Cover Disassembly

- Remove the two bolts (6C) holding disconnect cap (6D) to cover (6A).
- Remove disconnect cap (6D) from top of cover cap (6B) and cover (6A).
- Remove the two bolts (6C) attaching cover cap (6B) to cover (6A).
- Remove cover cap (6B) from cover (6A).
- Remove disconnect rod (6K) from cover cap (6B).
- Pry o-ring (6F) out of the groove inside cover cap (6B). Discard the o-ring.
- Remove o-ring (6G) from the flange of cover cap (6B). Discard the o-ring.
- Remove pipe plug (6H) from cover (6A).
- At this point the cover disassembly is complete.

Carrier Disassembly

NOTE: When removing the needle rollers from the cluster gears, discard the old needle rollers and use new ones during re-assembly.

- Using a punch and hammer, drive roll pin (3G) into planet shaft (3E).

NOTE: Be sure to drive the roll pin all the way into the planet shaft. Failure to do so could result in damage to the carrier when removing the planet shaft from the carrier.

- Using a punch and hammer, drive the planet shaft (3E) out of the planet shaft hole in the carrier housing (3A).
- When removing the planet shaft (3E) from the carrier housing, one thrust washer (38), one cluster gear (3F), and one more thrust washer will come off of the planet shaft and come to rest inside the carrier. Remove these parts from inside the carrier.
- Remove 16 needle rollers (3C) from inside one end of cluster gear (3F). Discard the needle rollers.

- Remove one spacer (3D) from inside cluster gear (3F).
- Remove the remaining 16 needle rollers (3C) from the other side of cluster gear (3F). Discard the needle rollers.
- Repeat steps 1-6 to remove and disassemble the two remaining cluster gears.
- At this point the carrier disassembly is complete.

Assembly of the Carrier

- Apply grease to the inside of one cluster gear (3F) and line one half of cluster gear with 16 needle rollers (3C).

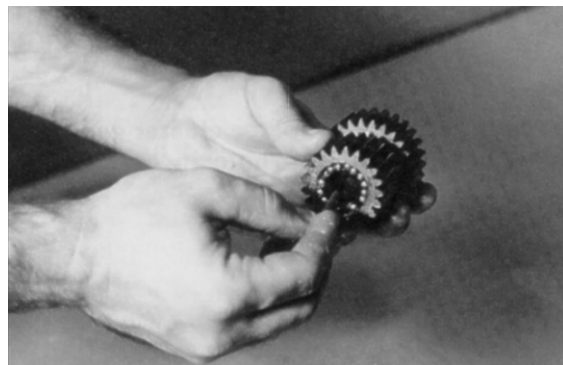

- Place one spacer (3D) inside cluster gear (3F) so that it rests on top of the needle rollers.



- Line the remaining half of cluster gear (3F) with 16 needle rollers.

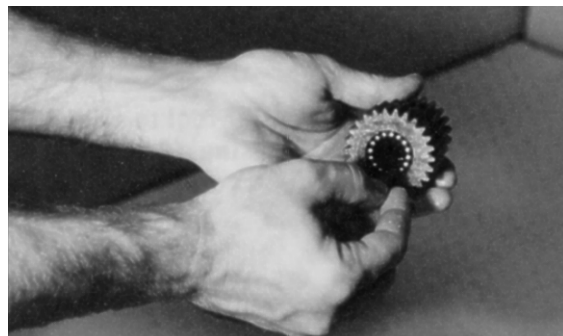

SECTION 3 - CHASSIS, PLATFORM & SCISSOR ARMS

4. Set carrier housing (3A) sideways on a table. Insert a planet shaft (3E), roll pin hole last, into one of the planet shaft holes from roll-pin-holed side of carrier housing.

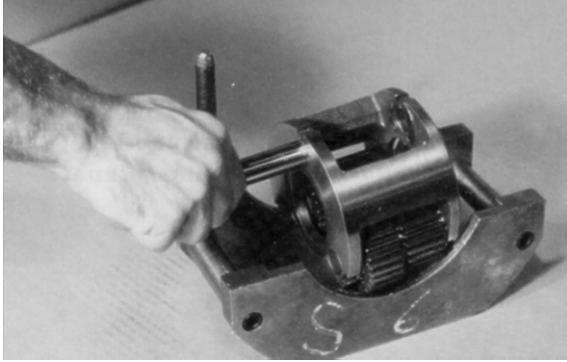

5. Place one thrust washer (3B) onto the end of planet shaft (3E) inside carrier. Fit tang of thrust washer into the slot on the inside edge of the planet shaft hole.



6. Following the thrust washer, place the cluster gear (3F), large end toward roll pin hole in carrier housing, onto the planet shaft (3E).

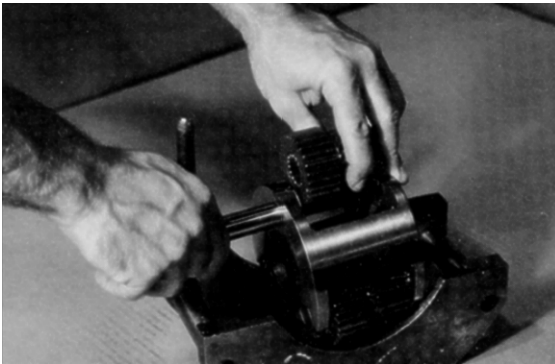

7. Following the cluster gear, place one more thrust washer (3B) onto planet shaft (3E) through the opposite planet shaft hole in carrier housing (3A).

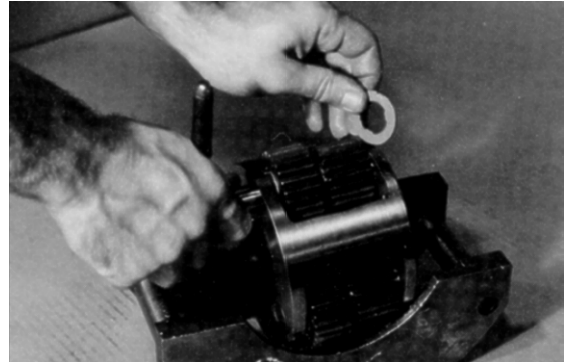

8. Use an alignment punch or similar tool to align the roll pin holes in carrier housing (3A) and planet shaft (3E).

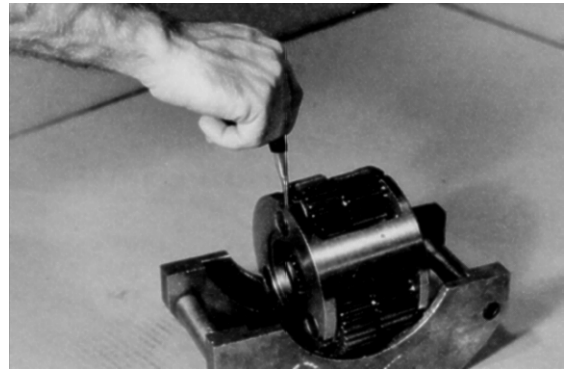

9. Drive roll pin (3G) down into the aligned roll pin holes in carrier housing (3A) and planet shaft (3E).

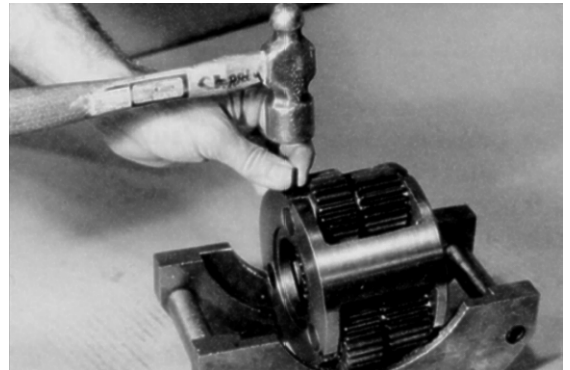

10. Repeat steps 1 thru 9 to assemble and install the two remaining cluster gears.
11. At this point the carrier sub-assembly is complete.

Cover Sub-Assembly

1. Using the disconnect rod, push o-ring (6F) into the groove inside the cover cap (6B).

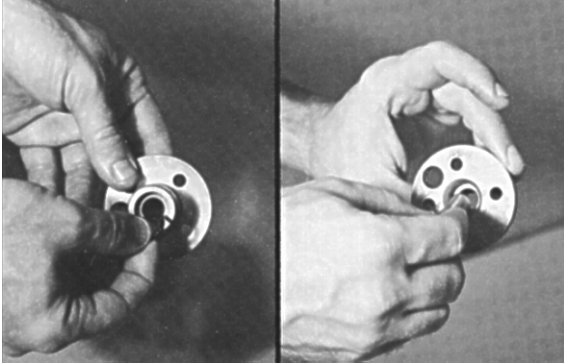

2. Place the o-ring (6G) onto the cover cap (6B) so that it rests against the flange of the cover cap.

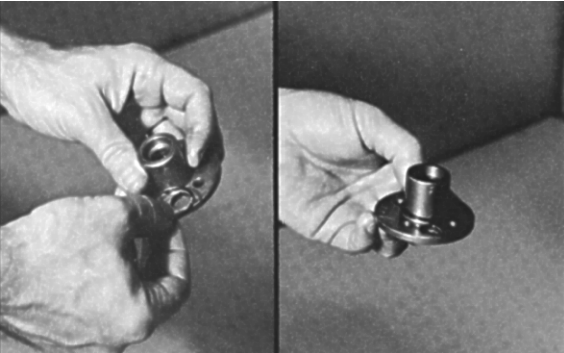

3. Insert disconnect rod (6E) into cover cap (6B).

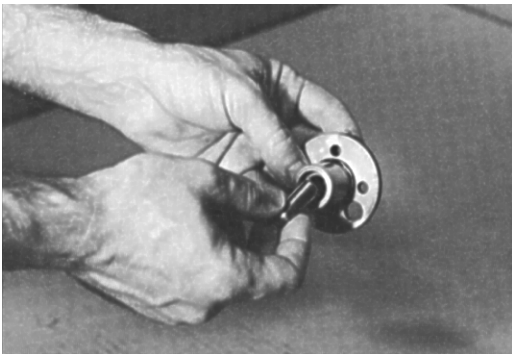

4. Set cover (6A) on table, exterior side up. Place cover cap (6B) onto cover (6A), aligning the pipe plug hole in the cover cap over the pipe plug hole in the cover.



5. Place two of the cover cap bolts (6C) into any two bolt holes that are 180° apart on the cover cap (6B) and tighten bolts.



6. Using a torque wrench, apply 2.95 to 3.69 ft. lbs. (4 to 5 Nm) of torque to both bolts (6C).

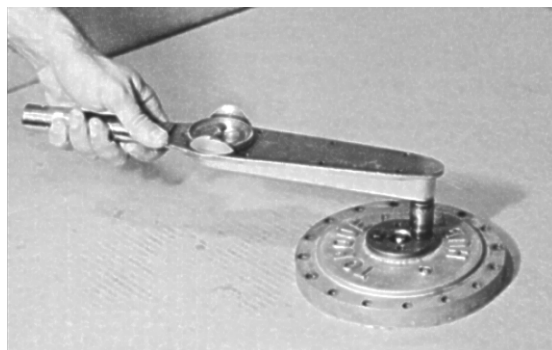

7. With the large end down, place the disconnect cap (6D) onto the cover cap (6B), aligning the pipe plug hole in the disconnect cap over the pipe plug hole in the cover cap.



8. Place the two remaining bolts (6C) into the bolt holes in the disconnect cap (6D), and tighten the bolts.



9. Using a torque wrench, apply 2.95 to 3.69 ft. lbs. (4 to 5 Nm) of torque to both bolts (6C).

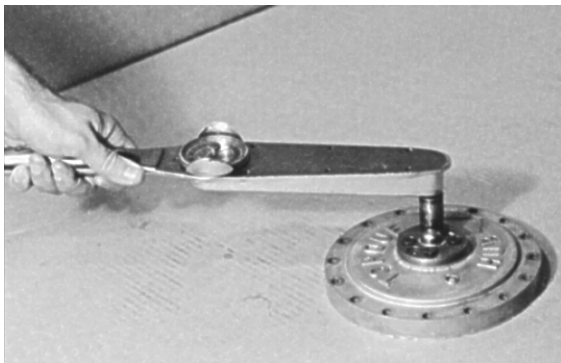

10. Apply a light coat of "Never-Seize" to pipe plug (6H) and tighten it into the pipe plug hole in the cover (6A).



Hub-Spindle Sub-Assembly

NOTE: Make sure the cup sits square with the counterbore before pressing.

1. Set hub (1G) onto its large end. Press bearing cup (1C) into the counterbore in the small end of the hub (1G).

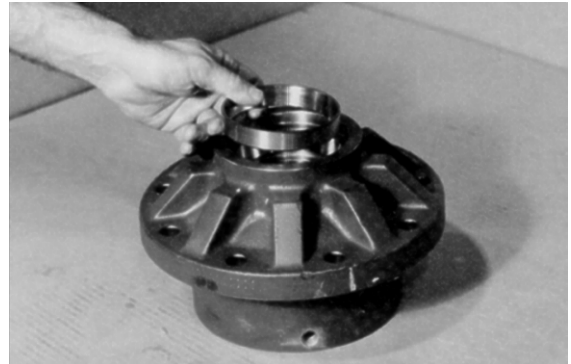

2. Press the nine studs (1N) into the stud holes in hub (1G).

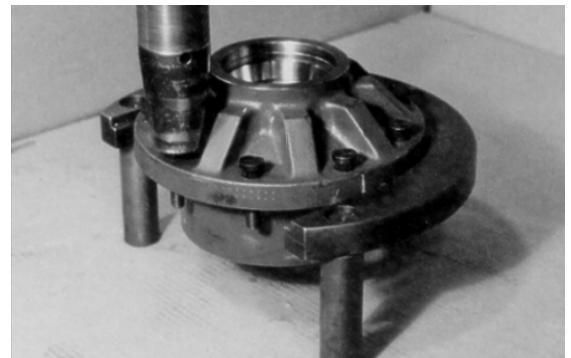

SECTION 3 - CHASSIS, PLATFORM & SCISSOR ARMS

3. Apply a light coat of "Never-Seize" to two pipe plugs (1J) and tighten them into the two pipe plug holes in the side of the hub (1G).

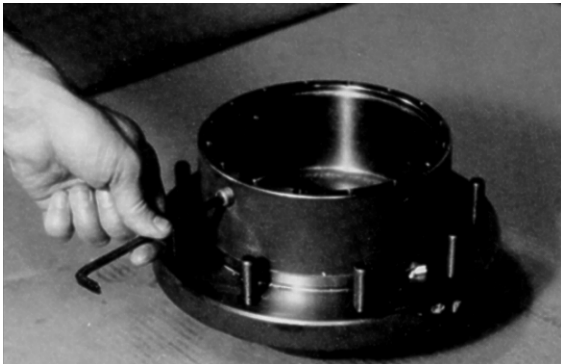

NOTE: Make sure the cup sits square with the counterbore before pressing.

4. Turn hub (1G) over onto its small end. Press bearing cup (1E) down into the counterbore in the deep end of the hub (1G).

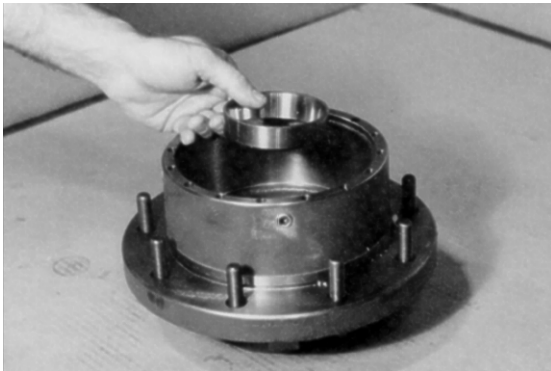

5. Set hub (1G) onto its large end. Place bearing cone (1D) into bearing cup (1C).

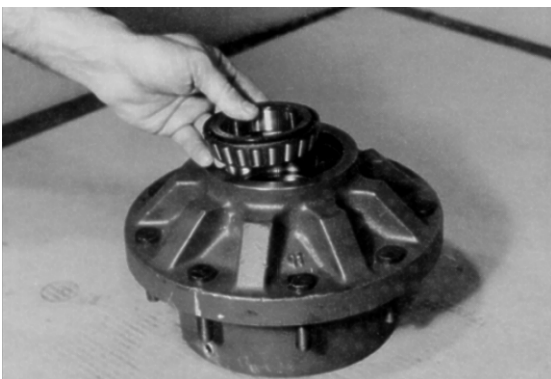

6. Press seal (1B) into the small end of hub (1G).



7. Oil spindle, then lower hub (1G), small end down, onto spindle (1A).



8. Press bearing cone (1F) onto spindle (1A) in hub (1G).

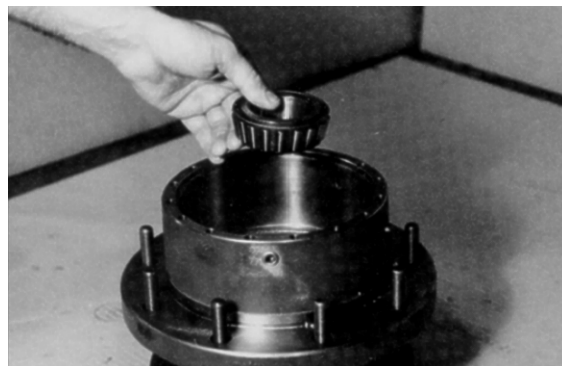

9. Place spacer (1H) onto spindle (1A) in hub (1G).



NOTE: Make sure the retaining ring is securely seated in the groove.

10. Place retaining ring (1I) over the spacer onto spindle (1A) in hub (1G).



11. At this point the hub-spindle sub-assembly is complete.

Main Assembly

⚠ WARNING

BEWARE OF SHARP EDGES IN COUNTERBORE WHEN INSTALLING THE O-RING

1. Grease o-ring (5) and place it into the counterbore in hub (1G).

NOTE: O-ring may be stretched or pinched together to make it fit the counterbore exactly.

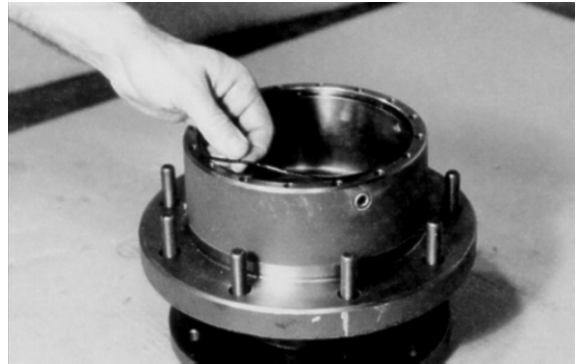

2. Oil all exposed surfaces inside hub (1G).



3. Place internal gear (2) into hub (1G) so that its internal splines mesh with the external splines of spindle (1A). Oil internal gear (2).

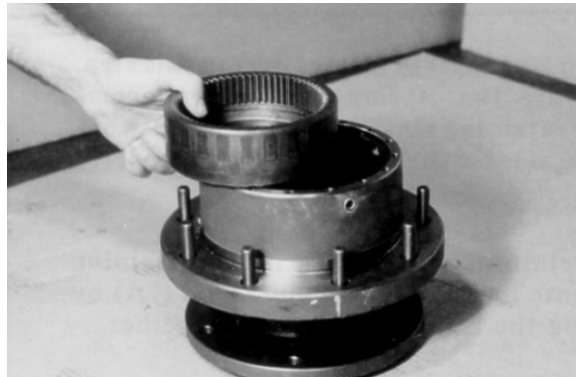

SECTION 3 - CHASSIS, PLATFORM & SCISSOR ARMS

4. Place thrust washer (11) around spindle (1A) so it rests on the bottom of the internal gear (2).

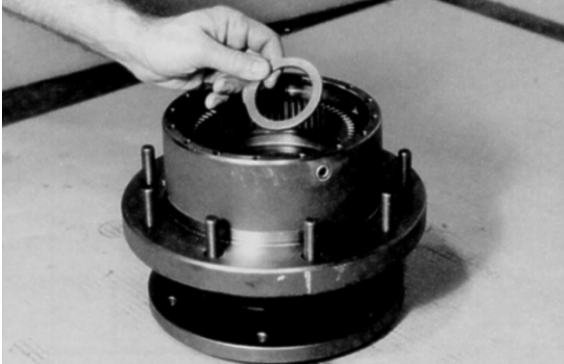

7. Place other spacer (7D) onto the smooth end of input shaft (7A).



5. Stand input shaft (7A) on its splined end. Place one spacer (7D) onto the smooth end of input shaft (7A).



6. Place one spring (7C) onto the smooth end of input shaft (7A).



⚠ WARNING

WEAR SAFETY GLASSES DURING THIS STEP, AND BE AWARE THAT SPRING AND SPACERS, COMPRESSED BY RETAINING RING, MAY POP SUDDENLY OFF SHAFT IF THE RING IS RELEASED BEFORE IT IS PROPERLY IN PLACE.

8. Using retaining ring pliers, insert retaining ring (7B) into the groove on input shaft (7A) by compressing the spring and spacers together.

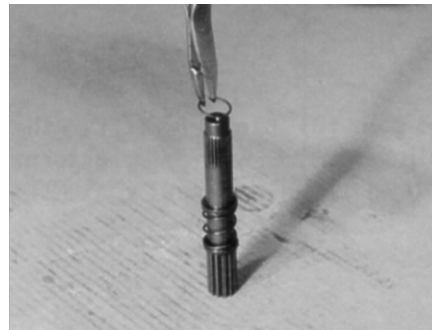

9. With large splined end down, place input shaft sub-assembly (7) into spindle (1A).

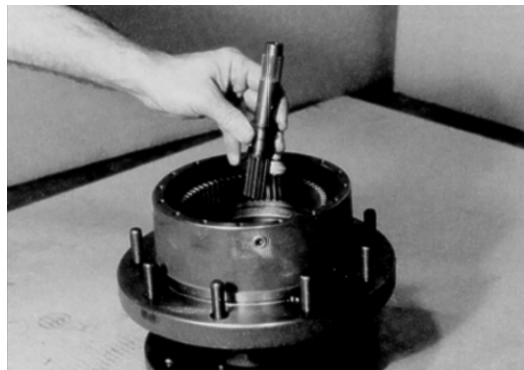

10. Place thrust spacer (9) onto input shaft (7).

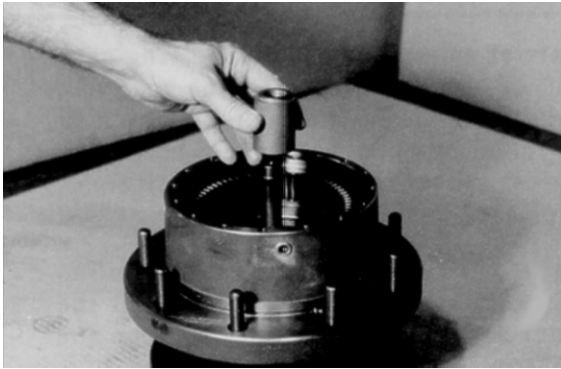

11. Set carrier sub-assembly (3) on a flat work surface so the large ends of cluster gears (3F) face up. Locate the punch marks on the face of each cluster gear (3F) and position them at 12 o'clock.

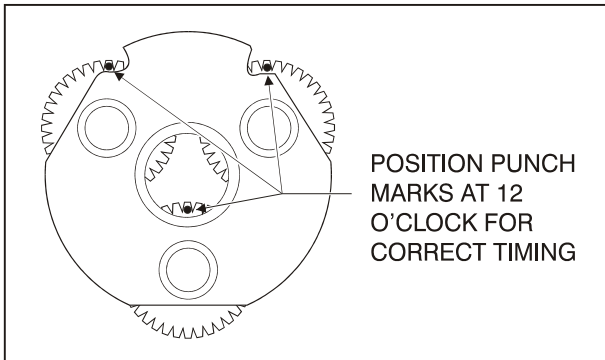
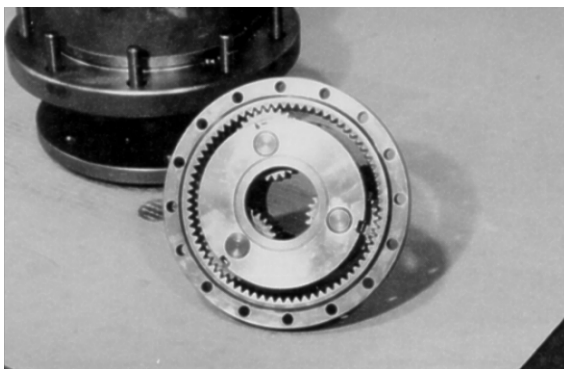

Figure 3-8. Cluster Gear Punch Marks

12. With "X" marked side facing up, place the ring gear (4) around cluster gears (3F).

NOTE: This will hold the punch marks in position while installing the carrier into the hub.



13. Place the carrier sub assembly (3) and ring gear (4) together into mesh with internal gear (2), aligning the "X" marked shoulder bolt hole in the ring gear (4) over one of the shoulder bolt holes in the hub. Mark

the location of shoulder bolt holes on the outside of ring gear and hub.

NOTE: You may lift the ring gear off the hub to align the shoulder bolt holes. The ring gear and carrier are installed together only to keep the punch marks on the carrier in place.

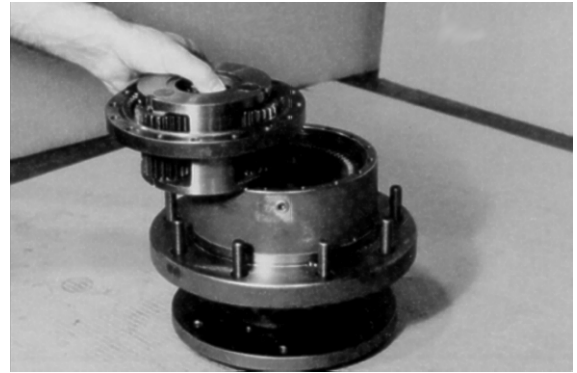

14. With the internal splines facing up (counterbore end facing down), place input gear (8) into mesh with carrier sub-assembly (3).

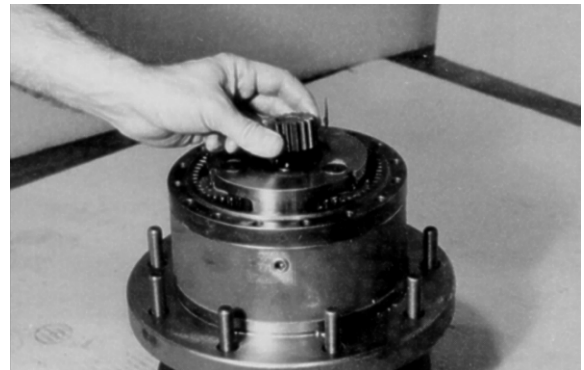

15. Oil all exposed surfaces inside the hub (1G). Place thrust washer (11) into the counterbore in top of the carrier.

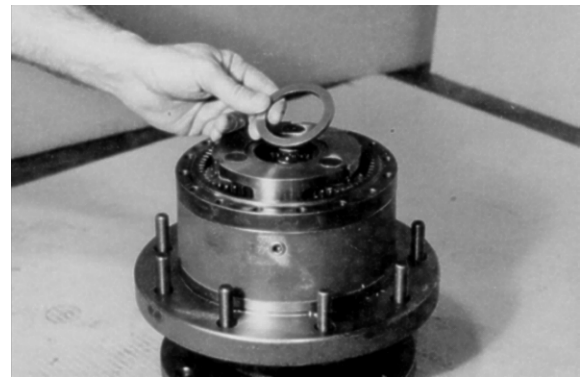

⚠ WARNING

BEWARE OF SHARP EDGES IN THE COUNTERBORE WHEN YOU INSTALL THE O-RING.

SECTION 3 - CHASSIS, PLATFORM & SCISSOR ARMS

16. Set the cover (6A) on table, interior side up. Grease o-ring (5) and place it into the counterbore around the edge of cover (6A).

NOTE: The o-ring may be stretched or pinched together to make it fit the counterbore exactly.



17. Place cover sub-assembly (6) onto ring gear (4), aligning the pipe plug holes according to the alignment prior to disassembly.



18. Place four flatwashers (16) on top of the bolt holes in the cover sub-assembly.

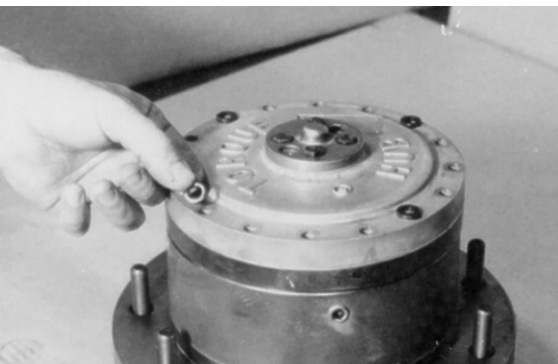

19. Place shoulder bolts (13) into the four shoulder bolt holes in cover (6) and tighten by hand.



20. Place the remaining 12 flatwashers (16) onto the remaining bolt holes in cover (6).

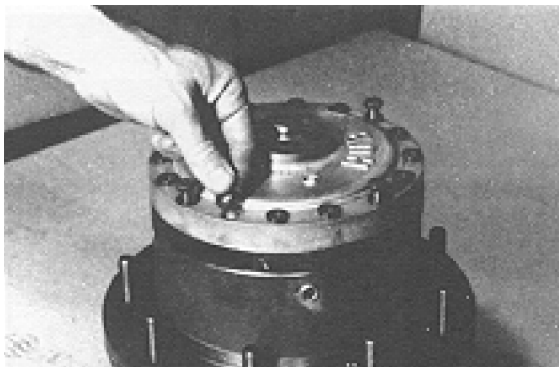

21. Place the 12 bolts into the remaining bolt holes in cover (6) and tighten.



22. Torque the shoulder bolts (13) 18 to 25 ft. lbs. (25 to 34 Nm). Torque bolts (12) 18 to 25 ft. lbs. (25 to 34 Nm).

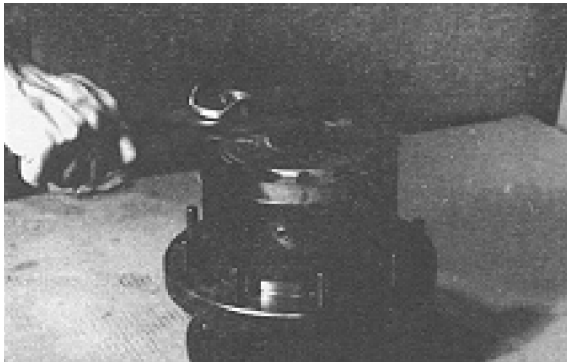

23. Turn hub (1G) over onto its side. Insert coupling (14) into the end of the spindle (1A).

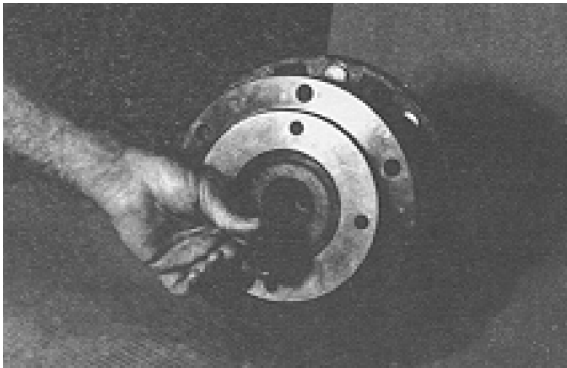

24. Roll test the unit in both clockwise and counterclockwise directions. Perform the same number of turns in each direction as the ratio of the unit. The ratio is the last two digits of the model number on the unit's ID tag.

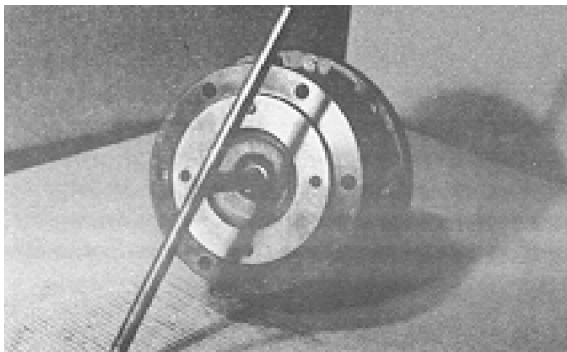

25. Leak test the unit at a pressure of 5 psi (0.34 bar) for 2 to 3 minutes.

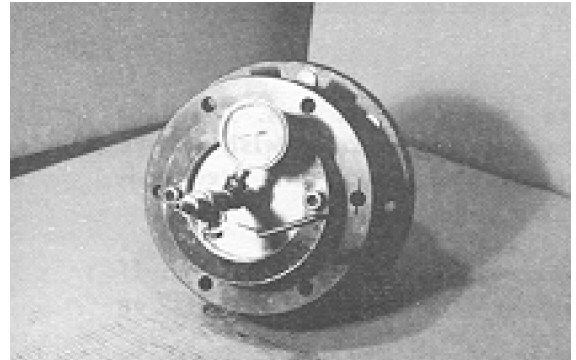

26. At this point the main assembly is complete.

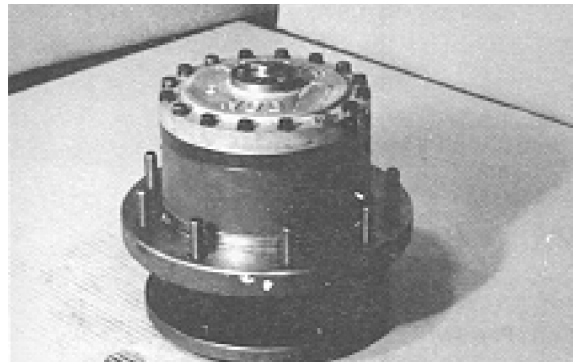

SECTION 3 - CHASSIS, PLATFORM & SCISSOR ARMS

Tool List

The following specialized tools are used to assemble this unit. The tool diagrams included in this manual are intended for the customer who may wish to have a tool made. All tools exist as one piece and must be made from mild steel. All dimensions are given in inches.

NOTE: In order to improve tool life, tools may be carburized and hardened. If this is done, however, the tools must be ground on all surfaces labeled with a "G" on the tool diagram.

1. T-118126 SEAL PRESSING TOOL for SEAL (1B).

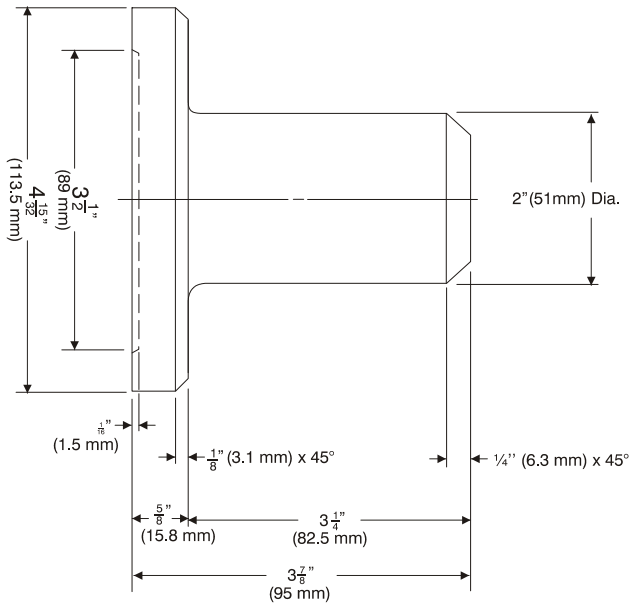

2. T-138903 ASSEMBLY PRESSING TOOL for CUP (1C)

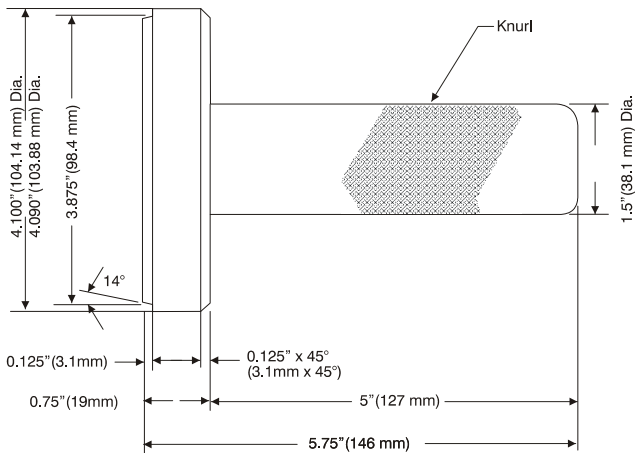

3. T-140433 ASSEMBLY PRESSING TOOL for CUP (1E)

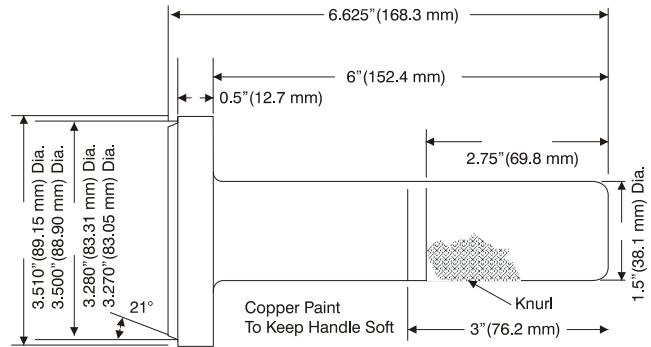

4. T-109691 ASSEMBLY PRESSING TOOL for CONE (1F)

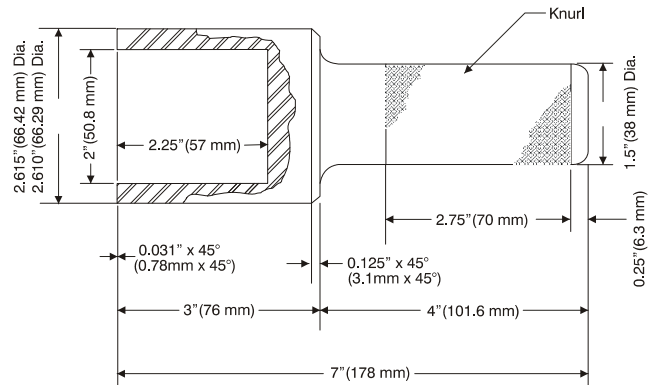

* These tools are for specific seals, cups or cones. There is a specific tool for each cup and cone.

Re-Aligning Torque Hub Input Coupling

The following procedure applies to torque hubs with integral brakes.

EQUIPMENT REQUIRED

1. Hydraulic power supply (hand pump) capable of producing 200 psi (13.8 bar).
2. Hydraulic fittings to adapt hydraulic supply to brake release port on hub.

PROCEDURE

1. Using appropriate fittings, connect a line from the hydraulic power supply to the brake port.
2. Pressurize the brake release port 155 to 200 psi (10.6 to 13.8 bar) to release the brake.
3. Verify that the brake is released by rotating the input coupling or hub spindle.
4. Once the brake is released, the input coupling will be free to re-align with the drive motor.

5. Install the drive motor on the hub, then release the hydraulic pressure at the brake release port. The coupling will remain in position.

Disconnect the hydraulic power supply and reconnect the line going into the brake release port.

3.5 DRIVE MOTOR (SAUER)

Description

The drive motors are low to medium power, two-position axial piston motors incorporating an integral servo piston. They are designed for operation in both open and closed circuit applications. The standard control is a direct acting single line hydraulic control. The integral servo piston controls motor displacement.

The motors are spring biased to maximum displacement and hydraulically shifted to minimum displacement. Minimum and maximum displacement can be set with fixed internal stops. The large diameter servo piston allows smooth acceleration and deceleration with relatively large circuit orificing.

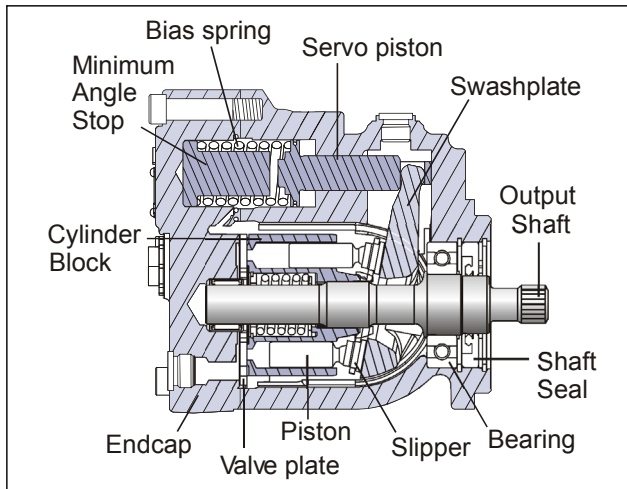
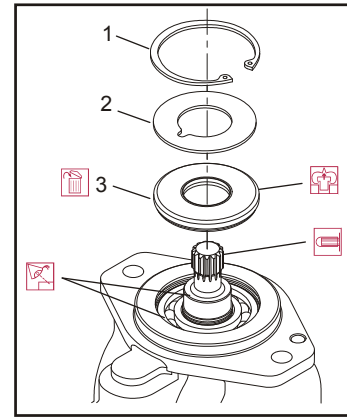

Figure 3-9. Drive Motor Cross Section

Shaft Seal Replacement

REMOVAL

1. Remove the snap ring (1) retaining the shaft seal and support washer.



1. Snap Ring
2. Support Washer
3. Shaft Seal

Figure 3-10. Removing the Shaft Seal

2. Remove the support washer (2).
3. Carefully pry out the shaft seal (3).

To avoid damaging the shaft during removal, install a large sheet metal screw into the chuck of a slide hammer. Drive the screw into the seal surface and use the slide hammer to pull the seal.

4. Discard the seal.

SECTION 3 - CHASSIS, PLATFORM & SCISSOR ARMS

INSPECT THE COMPONENTS

Inspect the new seal, the motor housing seal bore, and the sealing area on the shaft for rust, wear, and contamination. Polish the shaft and clean the housing if necessary.

INSTALLATION

1. Cover the shaft splines with an installation sleeve to protect the shaft seal during installation.
2. Install a new shaft seal with the cupped side facing the motor. Press seal into housing until it bottoms out. Press evenly to avoid binding and damaging the seal.
3. Install seal support washer.
4. Install snap ring.
5. Remove the installation sleeve.

Loop Flushing Valve

REMOVAL

1. Using a 11/16 in internal hex wrench, remove plug (1) and (2).

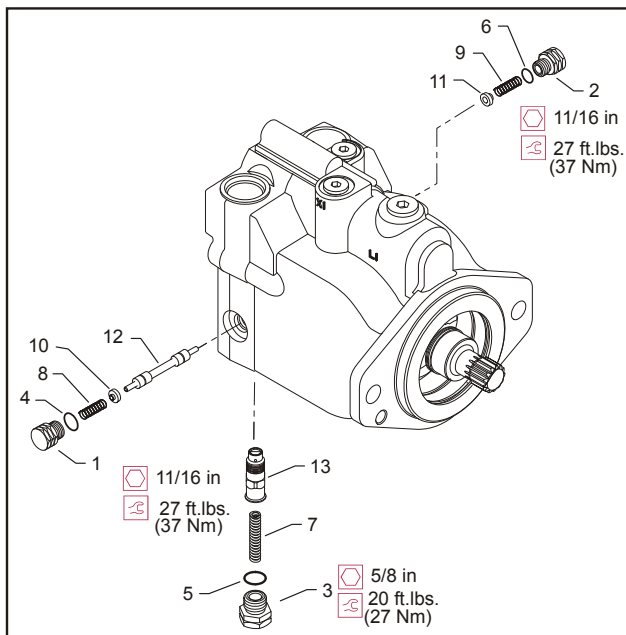

- | | | |
|-----------|------------|--------------------|
| 1. Plug | 6. O-ring | 11. Washer |
| 2. Plug | 7. Spring | 12. Shift Spool |
| 3. Plug | 8. Spring | 13. Orifice Poppet |
| 4. O-ring | 9. Spring | |
| 5. O-ring | 10. Washer | |

Figure 3-11. Loop Flushing Spool

2. Using a 1/4 in hex wrench, remove plug (3).
3. Remove O-rings (4, 5, and 6).
4. Using pliers, remove centering springs (7, 8, and 9).
5. Remove spring retaining washers (10 and 11).
6. Remove shift spool (12).
7. Remove orifice poppet (13).

INSPECT THE COMPONENTS

Inspect new O-rings and the sealing area for rust, wear, or contamination. Also check springs and poppet for wear.

INSTALLATION

1. Install orifice poppet (13).
2. Install shift spool (12).
3. Install spring retaining washers onto springs (10 and 11).
4. Carefully install centering springs (7, 8, and 9).
5. Install new O-rings (6, 4, and 5).
6. Using a 1/4 in hex wrench, torque plug (3) to 20 ft. lbs. (27 Nm).
7. Using a 11/16 in internal hex, torque plugs (2 and 1) to 27 ft. lbs. (37 Nm).

Troubleshooting

Table 3-5. Excessive Noise and/or Vibration

Item	Description	Action
Check oil level in reservoir and oil supply to the motor.	Insufficient hydraulic fluid could lead to cavitation that would cause system noise.	Fill the reservoir to the proper level and ensure that oil supply to the motor is adequate and the lines are unobstructed.
Check for air in the system.	Air trapped within the system lines, or the motor itself, could result in cavitation that would cause system noise.	Ensure that all of the system lines and components are purged of air.
Inspect the output shaft couplings.	A loose or incorrect shaft coupling will produce vibrations that could result in system noise.	Ensure that the correct coupling is used and that it fits properly onto the shaft.
Inspect the output shaft alignment.	Misaligned shafts create excessive frictional vibration that could result in system noise.	Ensure that the shafts are properly aligned.
Hydraulic oil viscosity above limits.	Viscosity above acceptable limits will result in cavitation that would lead to system noise.	Replace hydraulic oil with appropriate fluid for operating conditions.

Table 3-6. System Operating Hot

Item	Description	Action
Check oil level in reservoir and oil supply to the pump.	Insufficient amount of hydraulic fluid will not meet the cooling demands of the system.	Fill the reservoir to the proper level.
Inspect the heat exchanger, (if so equipped).	If the heat exchanger fails, or becomes obstructed, it may not meet the cooling demands of the system.	Ensure that heat exchanger is receiving adequate air flow and that the heat exchanger is in good operating condition. Repair or replace as necessary.
Check the system relief valves.	If a system relief valve becomes unseated for an extended period of time or fails for any other reason, the system could become overheated.	Repair or replace any malfunctioning relief valves as applicable and verify that the loads on the machine are not excessive.

Table 3-7. Won't Shift or Slow to Start

Item	Description	Action
Check the signal line to the servo control port.	Obstructed or restricted flow through the servo control signal lines could result in slow shift or no shift conditions within the motor.	Ensure that the signal lines are not obstructed or restricted and that signal pressure is adequate to shift the motor.
Check that the correct supply and drain orifices are properly installed, and are not obstructed.	Supply and drain orifices determine the shift rate of the motor. The smaller the orifice, the longer the time it takes to shift the motor. Obstruction will also increase shift times.	Ensure that the proper control orifices are installed in the motor and verify that they are not obstructed. Clean or replace as necessary.

Disassembly

NOTE: Removal of the endcap voids warranty.

During assembly, coat all moving parts with a film of clean hydraulic oil. This assures that these parts will be lubricated during start-up.

Replace all O-Rings and gaskets.

It is recommended that all O-rings be replaced. Lightly lubricate all O-rings with clean petroleum jelly prior to assembly.

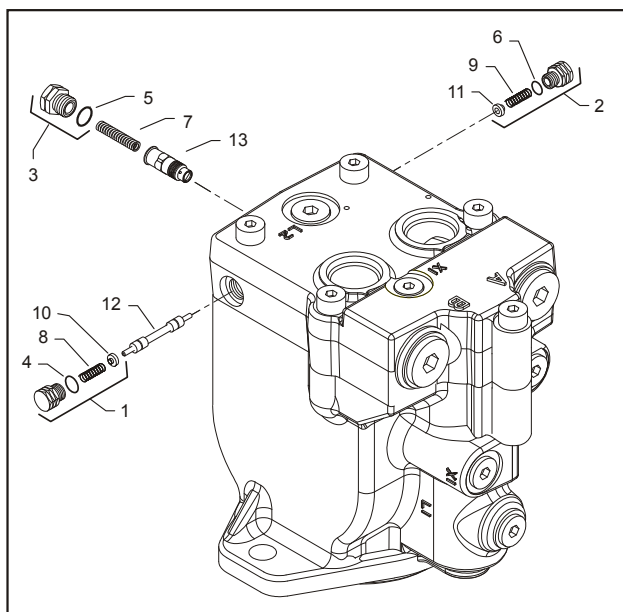

- | | | | |
|-----------|-----------|------------|--------------------|
| 1. Plug | 5. O-ring | 9. Spring | 12. Shift Spool |
| 2. Plug | 6. O-ring | 10. Washer | 13. Orifice Poppet |
| 3. Plug | 7. Spring | 11. Washer | |
| 4. O-ring | 8. Spring | | |

Figure 3-12. Loop Flushing Spool

1. Using a 11/16 in wrench, remove plug (1) and (2).
2. Using a 5/8 in hex wrench, remove plug (3).
3. Remove O-rings (4, 5, and 6).
4. Using pliers, remove centering springs (7, 8, and 9).
5. Remove spring retaining washers (10 and 11).
6. Remove shift spool (12).
7. Remove orifice poppet (13).

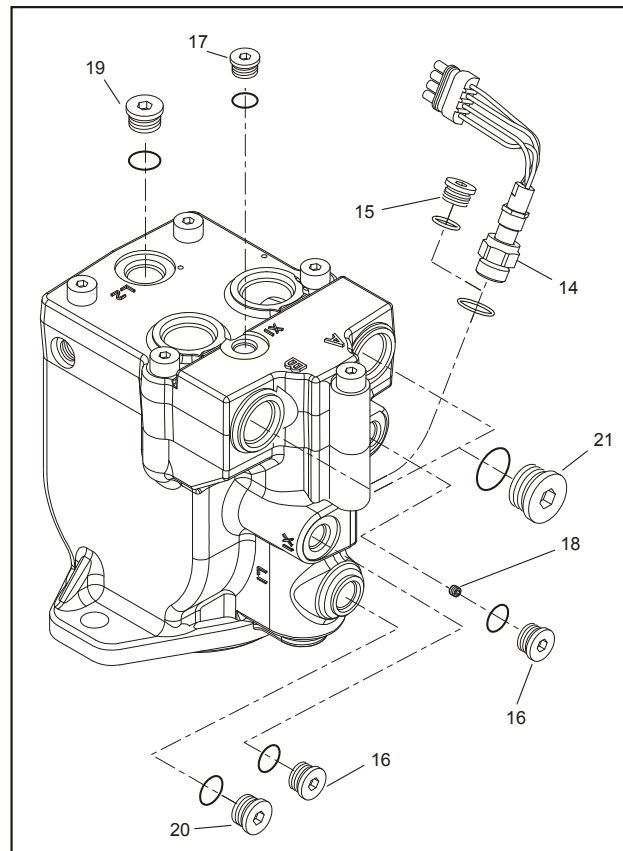

- | | |
|-----------------------|--------------------|
| 14. Lock Nut | 18. Cavity Plug |
| 15. O-ring Plug | 19. Drain Plug |
| 16. Control Line Plug | 20. Drain Plug |
| 17. Control Line Plug | 21. Work Port Plug |

Figure 3-13. Plugs, Fittings, and Speed Sensor

8. Remove all fittings from the unit. Discard any O-rings on the fittings.
9. Using an 11/16 in hex wrench, loosen the speed sensor lock nut (14) if equipped. Then remove the speed sensor using a 1/2 inch hex wrench. Units without speed sensor have an O-ring plug (15) installed in that location; remove it with a 1/4 inch internal hex wrench.
10. Using a 1/4 in internal hex wrench, remove control line plugs (16, 17). Discard O-rings. Using a 3 mm hex wrench, remove cavity plug (18, if equipped with two-line control) from X2 cavity.
11. Using a 5/16 in internal hex wrench, remove drain plugs (19, 20). Discard O-rings.

12. Using a 9/16 in internal hex wrench, remove work port plugs (21, if equipped with axial ports). Discard O-rings.

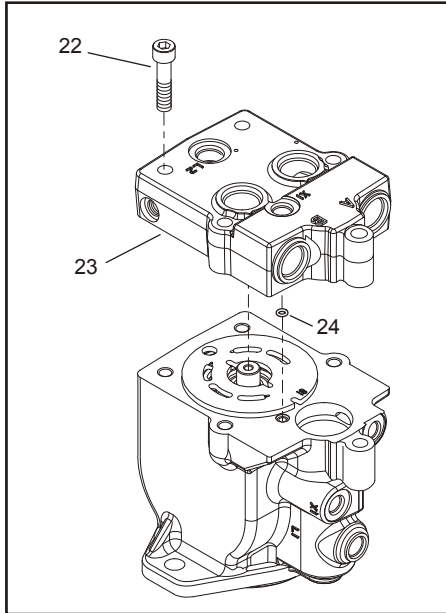

- 22. Screw
- 23. End Cap
- 24. O-ring

Figure 3-14. End Cap

13. Using an 8 mm internal hex wrench, remove the endcap screws (22).
14. Remove the endcap (23). Remove O-ring (24) from the housing or endcap.

When the endcap screws are removed, pressure from the servo spring will cause the endcap to bind on the shaft. Press down on the portion of the endcap covering the servo piston and hold the endcap level while removing.

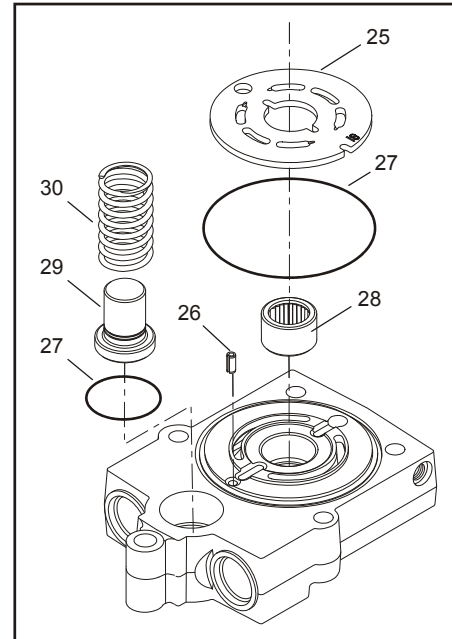

- 25. Valve Plate
- 26. End Cap
- 27. O-ring
- 28. Rear Shaft Bearing
- 29. Minimum Angle Stop
- 30. Servo Spring

Figure 3-15. Valve Plate & Rear Shaft Bearing

CAUTION

TAKE CARE NOT TO SCRATCH THE SURFACE OF THE VALVE PLATE.

15. Remove the valve plate (25) and timing pin (26) from the endcap.

Each displacement has a unique valve plate. For identification, the last two digits of the valve plate part number are stamped on its surface.

16. Remove and discard the O-rings (27).
17. Remove the rear shaft bearing (28) from the endcap with a bearing puller.

The bearing may be difficult to remove with a puller. Try this as an alternative: Pack the bearing cavity with heavy grease. After the shaft is removed, insert it into the bearing cavity and tap lightly with a soft mallet on the splined end. The grease will force the bearing out. Use caution not to drive the bearing past the rear shaft journal as the bearing may become trapped on the shaft and damaged.

SECTION 3 - CHASSIS, PLATFORM & SCISSOR ARMS

18. Remove minimum angle stop (29) and servo spring (30) from the housing.

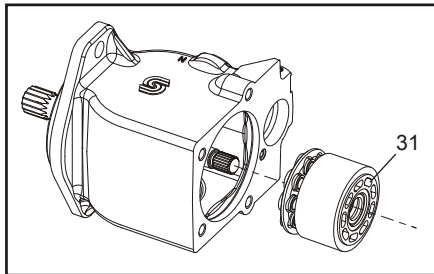

31. Cylinder Kit Assembly

Figure 3-16. Cylinder Kit

19. Turn the housing on its side and remove the cylinder kit assembly (31). Set the assembly aside, being careful not to scratch the running surface.

NOTE: Grooves on the surface of the cylinder kit identify its displacement:

Table 3-8. Displacement Identifiers

# of Grooves	Frame L	Frame K
1	25	38
2	30	45
3	35	--

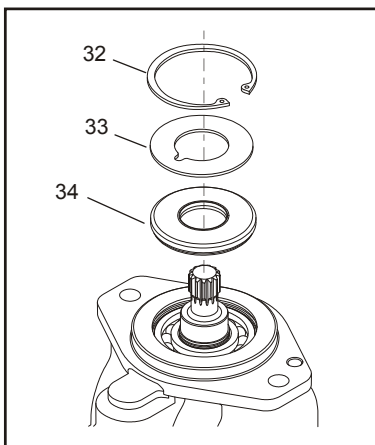

32. Snap Ring
33. Support Washer
34. Shaft Seal

Figure 3-17. Shaft Seal

20. Turn the housing over and remove the snap ring (32) retaining the shaft seal and support washer. Remove the support washer (33) and carefully pry out the

shaft seal (34). Discard the seal.

To avoid damaging the shaft during seal removal, install a large sheet metal screw into the chuck of a slide hammer. Drive the screw into the seal surface and use the slide hammer to pull the seal.

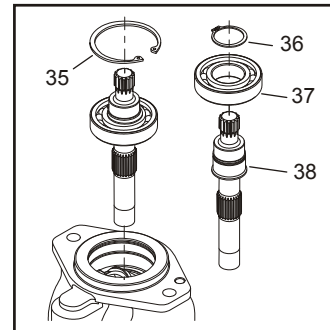

35. Inner Snap Ring
36. Snap Ring
37. Bearing
38. Shaft

Figure 3-18. Shaft & Front Bearing

21. Remove the inner snap ring (35) and the shaft / bearing assembly.
22. Remove the snap-ring (36) retaining the shaft front bearing. Pull the bearing (37) off of the shaft (38).

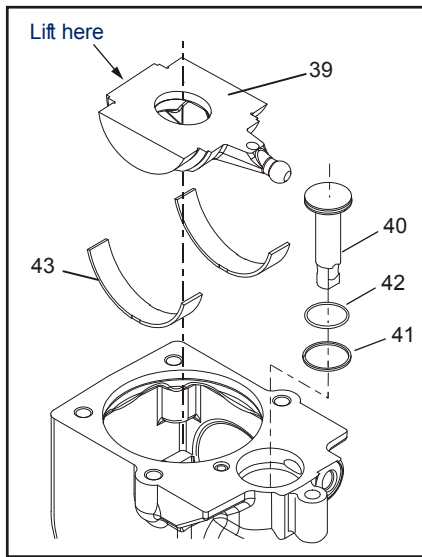

- 39. Swashplate
- 40. Servo Piston
- 41. Piston Seal
- 42. O-ring
- 43. Journal Bearings

Figure 3-19. Swash Plate & Servo Piston

23. Turn housing over and remove the swashplate (39) by lifting on the end opposite the servo lever.
24. Remove the servo piston (40). Remove the piston seal (41) and O-ring (42) from the servo piston. Discard the seal and O-ring.
25. Remove the journal bearings (43) from the housing. If the bearings are to be reused, note the location and orientation of each bearing for reassembly.

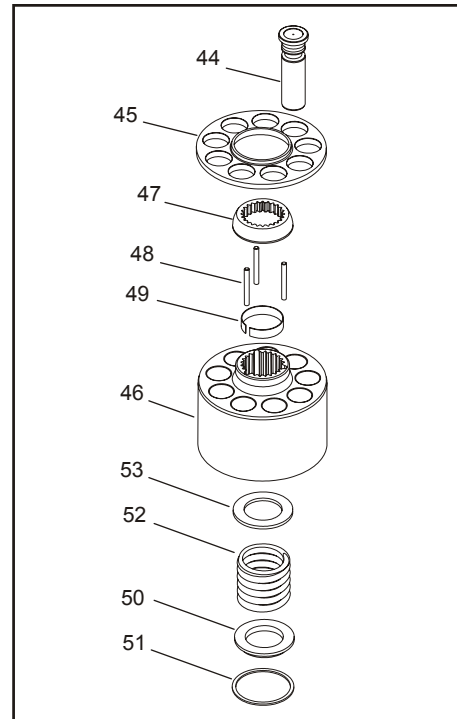

- 44. Piston
- 45. Slipper Retainer
- 46. Cylinder Block
- 47. Ball Guide
- 48. Hold-down Pins
- 49. Retaining Ring
- 50. Block Spring Washer
- 51. Spiral Retaining Ring
- 53. Inner Block Spring Washer

Figure 3-20. Cylinder Kit Disassembly

26. Remove pistons (44) and slipper retainer (45) from the cylinder block (46).

The pistons are not selectively fitted, however units with high hourly usage may develop wear patterns. Number the pistons and bores for reassembly if they are to be reused.

27. Remove the ball guide (47), hold-down pins (48), and retaining ring (49) from the cylinder block.

NOTE: Most repairs do not require block spring removal. Perform this procedure only if you suspect problems with the block spring.

⚠ WARNING

RISK OF PERSONAL INJURY: COMPRESSING THE BLOCK SPRING REQUIRES FORCE OF ABOUT 80 TO 90 LBF (350 TO 400 N). USE A PRESS SUFFICIENT TO MAINTAIN THIS FORCE WITH REASONABLE EFFORT. ENSURE THE SPRING IS SECURE BEFORE ATTEMPTING TO REMOVE THE SPIRAL RETAINING RING. RELEASE THE PRESSURE SLOWLY AFTER THE RETAINING RING IS REMOVED.

SECTION 3 - CHASSIS, PLATFORM & SCISSOR ARMS

28. Turn the block over. Using a press, apply pressure on the block spring washer (50) to compress the block spring. Compress the spring enough to safely remove the spiral retaining ring (51). While maintaining pressure, unwind the spiral retaining ring (51). Carefully release the pressure and remove the outer block spring washer (50), block spring (52), and inner block spring washer (53) from the cylinder block.

Inspection

After disassembly, wash all parts (including the end-cap and housing) thoroughly with clean solvent and allow to air dry. Blow out oil passages in the housing and endcap with compressed air. Conduct inspection in a clean area and keep all parts free from contamination. Clean and dry parts again after any rework or resurfacing.

PISTON

Inspect the pistons for damage and discoloration. Discolored pistons may indicate excessive heat; do not reuse.

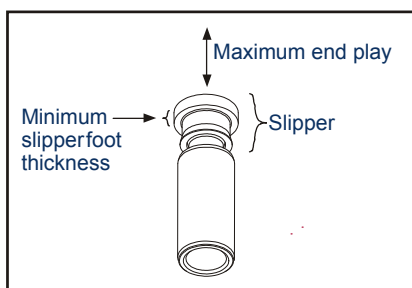

SLIPPERS

Inspect the running surface of the slippers. Replace any piston assemblies with scored or excessively rounded slipper edges. Measure the slipper foot thickness. Replace any piston assemblies with excessively worn slippers. Check the slipper axial end-play. Replace any piston assemblies with excessive end-play.

Minimum slipper foot thickness and maximum axial end-play are given in the table below.

Table 3-9. Slipper Foot Thickness & End Play

Measurement		L Frame	K Frame
Slipper Foot Thickness	mm (in.)	2.71 (0.11)	4.07 (0.16)
Piston/Slipper End Play		0.15 (0.006)	

CYLINDER BLOCK

Measure the cylinder block height. Replace blocks worn beyond the minimum height specification. Inspect the running surface of the cylinder block. Replace or resurface worn or scratched blocks. Blocks may be resurfaced to the specifications shown in the drawing, provided resurfacing will not reduce the block height below the minimum specification. Table 3-10, Cylinder Block Measurements.

Table 3-10. Cylinder Block Measurements

Measurement		L25	L30	L35	K38	K45
Minimum Cylinder Block Height (A)	mm (in.)	50.8 (2.00)	50.8 (2.00)	50.8 (2.00)	54.4 (2.14)	54.4 (2.14)
Cylinder Block Surface Flatness		0.002 (0.0000079)	0.002 (0.0000079)	0.002 (0.0000079)	0.002 (0.0000079)	0.002 (0.0000079)

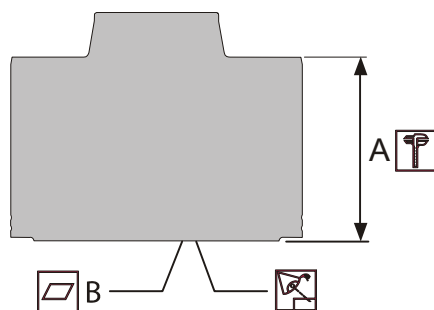

BALL GUIDE AND SLIPPER RETAINER

Inspect the ball guide and slipper retainer for damage, discoloration, or excessive wear. A discolored ball guide or slipper retainer indicates excessive heat. Do not reuse.

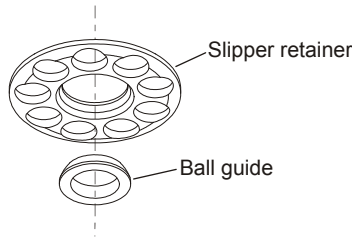

VALVE PLATE

The condition of the valve plate is critical to the efficiency of the motor. Inspect the valve plate surfaces carefully for excessive wear, grooves, or scratches. Replace or resurface grooved or scratched valve plates. Measure the valve plate thickness and replace if worn beyond the minimum specification. Valve plates may be resurfaced to the specifications shown in the drawing, provided resurfacing will not reduce the thickness below the minimum specification.

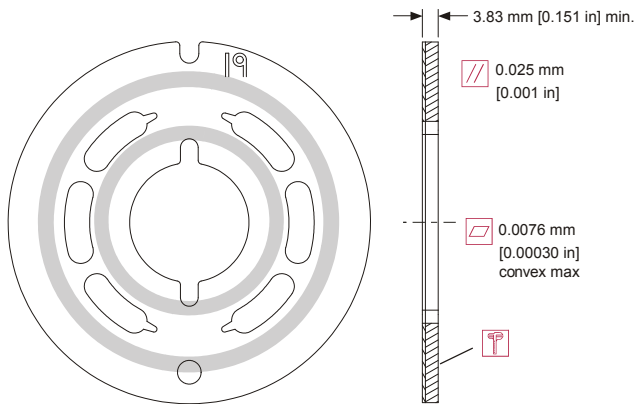

SWASHPLATE AND JOURNAL BEARINGS

Inspect the running face, servo ball-joint, and swashplate journal surfaces for damage or excessive wear. Some material transfer may appear on these surfaces and is acceptable providing the surface condition meets specifications shown. Measure the swashplate thickness from the journals to the running face. Replace swashplate if damaged or worn beyond minimum specification.

Replace swashplate if the difference in thickness from one side to the other exceeds specification.

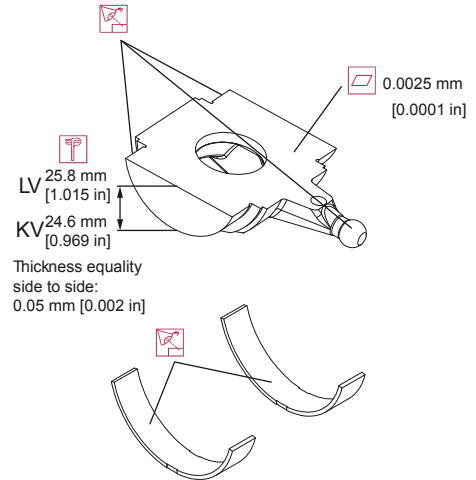

Inspect the journal bearings for damage or excessive wear. Replace journal bearings if scratched, warped, or excessively worn. The polymer wear layer must be smooth and intact.

SHAFT BEARINGS

Inspect bearings for excessive wear or contamination. Rotate the bearings while feeling for uneven movement. Bearings should spin smoothly and freely. Replace bearings that appear worn or do not rotate smoothly.

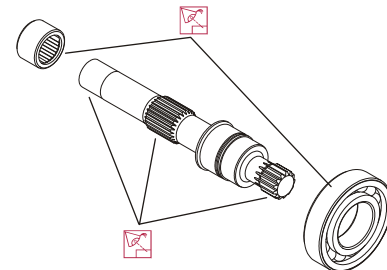

SHAFT

Inspect the motor shaft. Look for damage or excessive wear on the output and block splines. Inspect the bearing surfaces and sealing surface. Replace shafts with damaged or excessively worn splines, bearing surfaces, or sealing surfaces.

SERVO PISTON AND MINIMUM ANGLE STOP

Inspect the minimum angle stop, servo piston head, and servo piston ball-socket for damage or excessive wear. Replace if necessary.

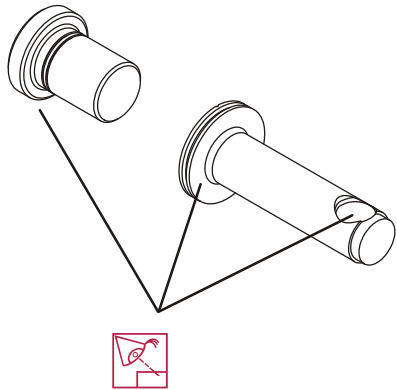

LOOP FLUSHING SPOOL

Inspect the loop flushing spool. Check for cracks or damage. Replace if necessary.

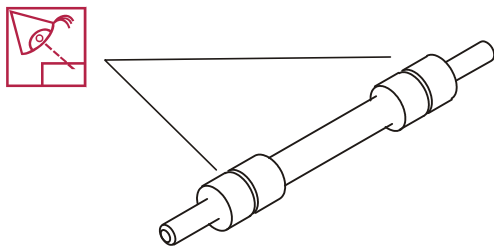

Assembly

1. Install new O-ring (1) and piston seal (2) to the servo piston (3). Install the piston seal over the O-ring.

Installing the piston seal stretches it, making it difficult to install the servo piston in its bore. Allow 30 minutes for the seal to relax after installation. To speed up seal relaxation, compress the seal by installing the piston head into the servo cavity in the end-cap and let it stand for at least five minutes.

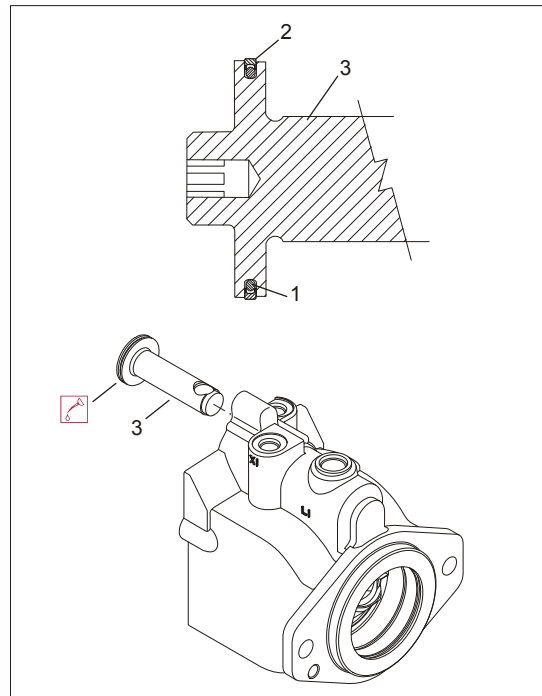

1. O-ring
2. Piston Seal
3. Servo Piston

Figure 3-21. Servo Piston

2. After piston seal has relaxed, lubricate and install servo piston into the housing bore. Align the piston with the ball socket facing the inside of the housing.

⚠ WARNING

RISK OF PERSONAL INJURY: COMPRESSING THE BLOCK SPRING REQUIRES ABOUT 80 TO 90 LBF (350 TO 400 N) OF FORCE. USE A PRESS SUFFICIENT TO MAINTAIN THIS FORCE WITH REASONABLE EFFORT. ENSURE THE SPRING IS SECURE BEFORE ATTEMPTING TO INSTALL THE SPIRAL RETAINING RING. RELEASE THE PRESSURE SLOWLY AFTER THE RETAINING RING IS INSTALLED.

3. Install the inner block spring washer (4), block spring (5), and outer washer (6) into the cylinder block. Using a press, compress the block spring enough to expose the retaining ring groove. Wind the spiral retaining ring (7) into the groove in the cylinder block.

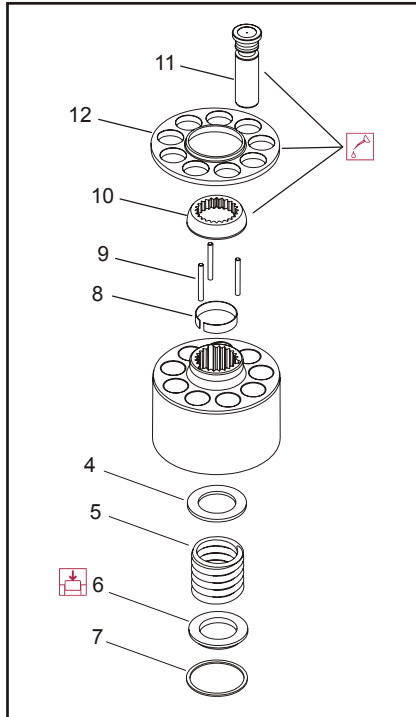

- | | |
|--------------------------|----------------------|
| 4. Block Spring Washer | 9. Holddown Pins |
| 5. Block Spring | 10. Ball Guide |
| 6. Outer Washer | 11. Piston |
| 7. Spiral Retaining Ring | 12. Slipper Retainer |
| 8. Retaining Ring | |

Figure 3-22. Cylinder Kit Assembly

4. Turn the block over and install the retaining ring (8), hold-down pins (9), and ball guide (10) to the cylinder block.
5. Install the pistons (11) to the slipper retainer (12). Install the piston/retainer assembly into the cylinder block. Ensure the concave surface of the retainer seats on the ball guide. If you're reusing the pistons, install them to the original block bores. Lubricate the pistons, slippers, retainer, and ball guide before assembly. Set the cylinder kit aside on a clean surface until needed.

6. Install the journal bearings (13) into the housing seats. Use assembly grease to keep the bearings seated during assembly. Ensure the locating nubs drop into the cavities in the seats. If you're reusing the bearings, install them in the original location and orientation. Lubricate the journal bearings.

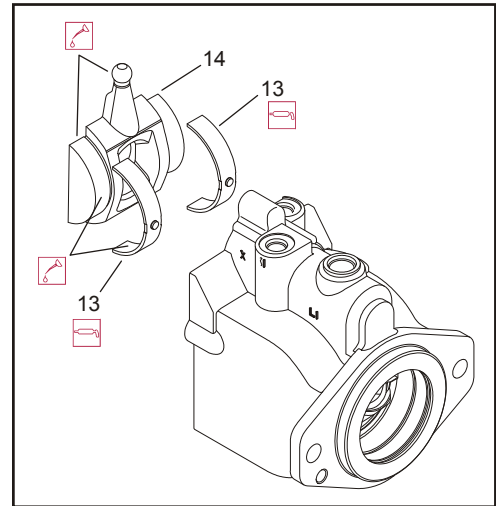

- | |
|----------------------|
| 13. Journal Bearings |
| 14. Swash Plate |

Figure 3-23. Swash Plate and Journal Bearing

7. Install the swashplate (14) into the housing. Tilt the swashplate and guide the servo lever ball into its socket in the servo piston rod. Ensure the swashplate seats into the journal bearings and moves freely. Lubricate the running surface of the swashplate.

SECTION 3 - CHASSIS, PLATFORM & SCISSOR ARMS

- Press front shaft bearing (15) onto shaft (16). Press bearing onto shaft with lettering facing out. Lubricate bearing rollers. Install snap-ring (17) onto shaft.

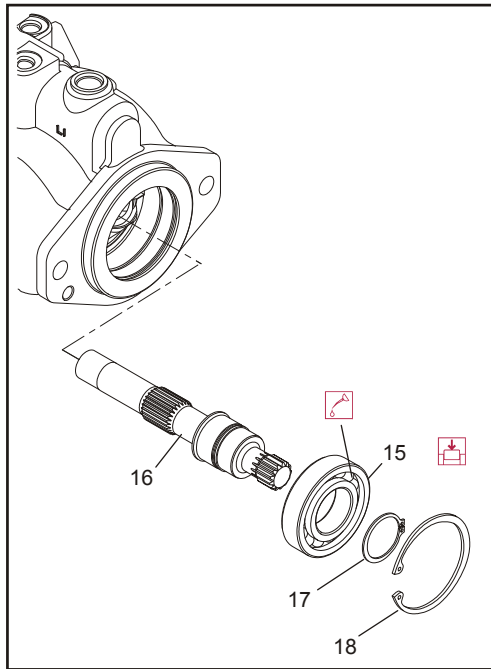

- 15. Front Shaft Bearing
- 16. Shaft
- 17. Snap Ring
- 18. Snap Ring

Figure 3-24. Shaft and Front Bearing

- While holding the swashplate in place, turn the housing on its side. Install the install shaft/bearing assembly into housing from the flange end. Install the snap-ring (18).

- Verify swashplate and bearings are properly seated. Install the cylinder kit (19) onto the shaft. Install with the slippers facing the swashplate. Rock the shaft to align the block splines and slide the cylinder kit into place. Orient the motor with the shaft pointing downward and verify the cylinder kit, swashplate, journal bearings, and servo piston are all secure and properly installed.

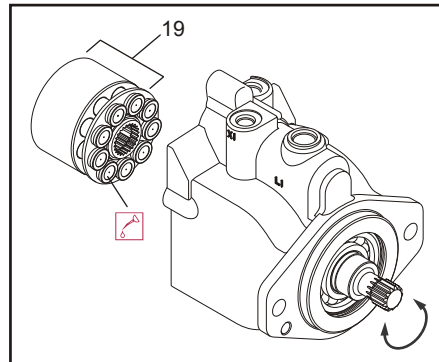

- 19. Cylinder Kit

Figure 3-25. Cylinder Kit Installation

- Lubricate and install the servo spring (20), and minimum angle stop (21) into the housing bore.

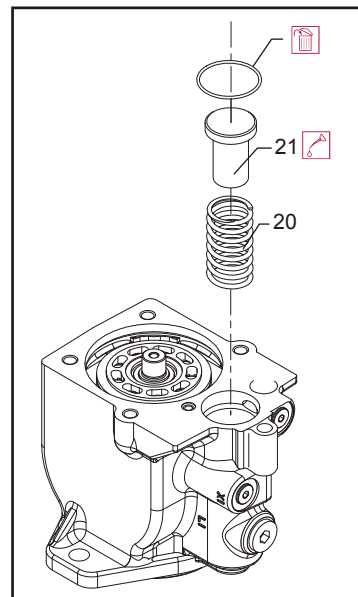

- 20. Servo Spring
- 21. Minimum Angle Stop

Figure 3-26. Servo Spring and Minimum Angle Stop

12. Press the rear shaft bearing (22) into the endcap. Install the bearing with letters facing out. Press until bearing surface is 0.08 ± 0.01 in (2 ± 0.25 mm) above endcap surface.

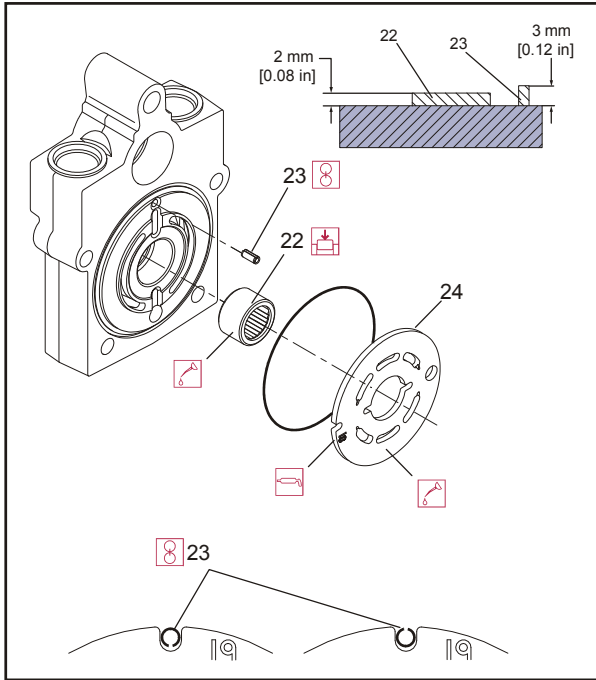

22. Rear Shaft Bearing
23. Timing Pin
24. Valve Plate

Figure 3-27. Valve Plate and Rear Bearing

13. Install timing pin (23) into its bore in the endcap. Install the pin with its groove facing toward or away from the shaft. Press the pin until the end protrudes 0.12 ± 0.01 in (3 ± 0.25 mm) above endcap surface.
14. Install the valve plate (24) onto the endcap. Install the valve plate with the yellow surface toward the cylinder block. Align the slot in the valve plate with the timing pin. Apply a liberal coat of assembly grease to the endcap side of the valve plate to keep it in place during installation.

15. Install the endcap (25) onto the housing with the endcap screws (26). Check to ensure the endcap will properly seat onto the housing without interference. Improper assembly of the internal components may prevent the endcap from seating properly. Ensure the O-rings seat properly when installing the endcap.

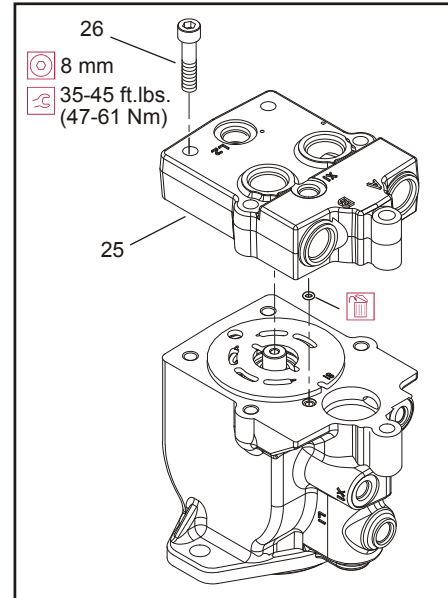

25. End Cap
26. Screw

Figure 3-28. End Cap

16. Using an 8 mm internal hex wrench, tighten the endcap screws. Tighten the screws in opposite corners slowly and evenly to compress the servo spring and properly seat the endcap. Torque endcap screws 35-45 lb-ft (47-61 Nm).
17. Before installing the shaft seal, ensure the shaft turns smoothly with less than 120 in.lbs. (13.5 Nm) of force. If the shaft does not turn smoothly within the specified maximum force, disassemble and check the unit.

SECTION 3 - CHASSIS, PLATFORM & SCISSOR ARMS

18. Cover shaft splines with an installation sleeve. Install a new shaft seal (27) with the cup side facing the motor. Press seal into housing until it bottoms out. Press evenly to avoid binding and damaging the seal. Install seal support washer (28) and snap ring (29).

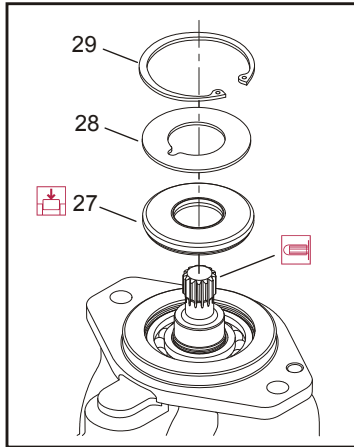

- 27. Shaft Seal
- 28. Seal Support Washer
- 29. Snap Ring

Figure 3-29. Shaft Seal

19. Install remaining plugs and fittings to the housing. Refer to the drawing below for wrench sizes and installation torques.

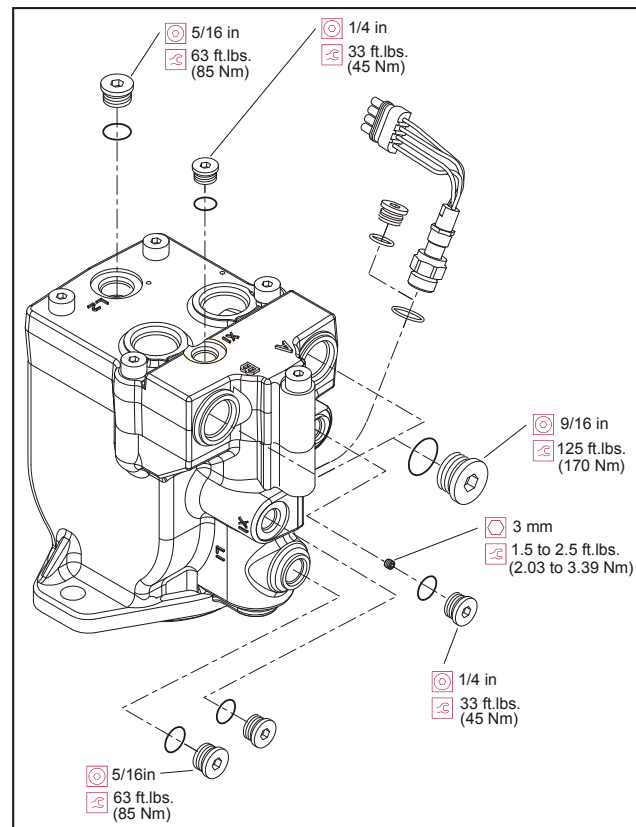
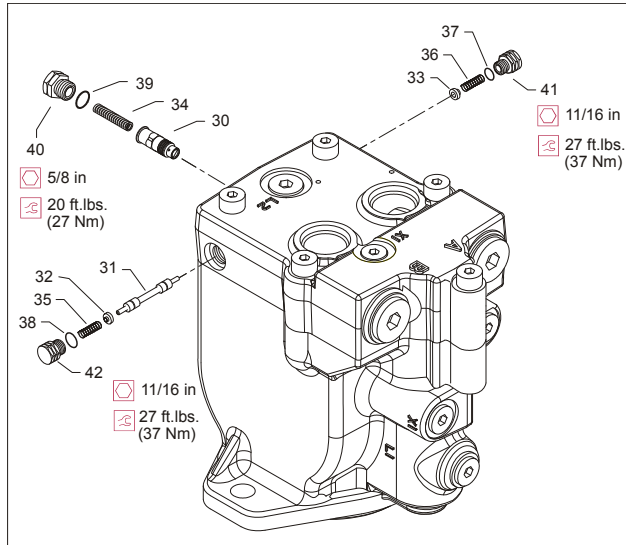

Figure 3-30. Plugs and Fittings Installation

20. Install orifice poppet (30).



- | | | | |
|--------------------|------------|------------|----------|
| 30. Orifice Poppet | 34. Spring | 37. O-ring | 40. Plug |
| 31. Shift Spool | 35. Spring | 38. O-ring | 41. Plug |
| 32. Spring | 36. Spring | 39. O-ring | 42. Plug |
| 33. Spring | | | |

Figure 3-31. Loop Flushing Spool

21. Install shift spool (31).
22. Install spring retaining washers onto springs (32 and 33).
23. Carefully install centering springs (34, 35, and 36).
24. Install new O-rings (37, 38, and 39).
25. Using a 5/8 in wrench torque plug (40) to 20 lb-ft (27 Nm).
26. Using a 11/16 in wrench, torque plugs (41 and 42) to 27 lb-ft (37 Nm).

Initial Start-up Procedures

Follow this procedure when starting-up a new motor or when installing a motor that has been removed.

Prior to installing the motor, inspect for damage incurred during shipping. Make certain all system components (reservoir, hoses, valves, fittings, heat exchanger, etc.) are clean prior to filling with fluid.

1. Fill the reservoir with recommended hydraulic fluid. Always filter fluid through a 10 micron filter when pouring into the reservoir. Never reuse hydraulic fluid.
2. Fill the inlet line leading from the pump to the reservoir. Check the inlet line for properly tightened fittings and ensure it is free of restrictions and air leaks.
3. Fill the pump and motor housing with clean hydraulic fluid. Pour filtered oil directly into the upper most case drain port.
4. To ensure the pump and motor stay filled with oil, install case drain lines into the upper most case drain ports.
5. Install a 0 to 500 psi (0 to 35 bar) gauge in the charge pressure gauge port of the pump to monitor system pressure during start up.
6. While watching the pressure gauge, run the engine at the lowest possible speed until system pressure builds to normal levels [minimum 160 psi (11 bar)]. Once system pressure is established, increase to full operating speed. If system pressure is not maintained, shut down the prime mover, determine cause, and take corrective action.
7. Operate the hydraulic system for at least fifteen minutes under light load conditions.
8. Check and adjust control settings as necessary after installation.
9. Shut down the prime mover and remove the pressure gauge. Replace plug at the charge pressure gauge port.
10. Check the fluid level in the reservoir; add clean filtered fluid if necessary. The motor is now ready for operation.

3.6 FRONT AXLE

Steering Assembly

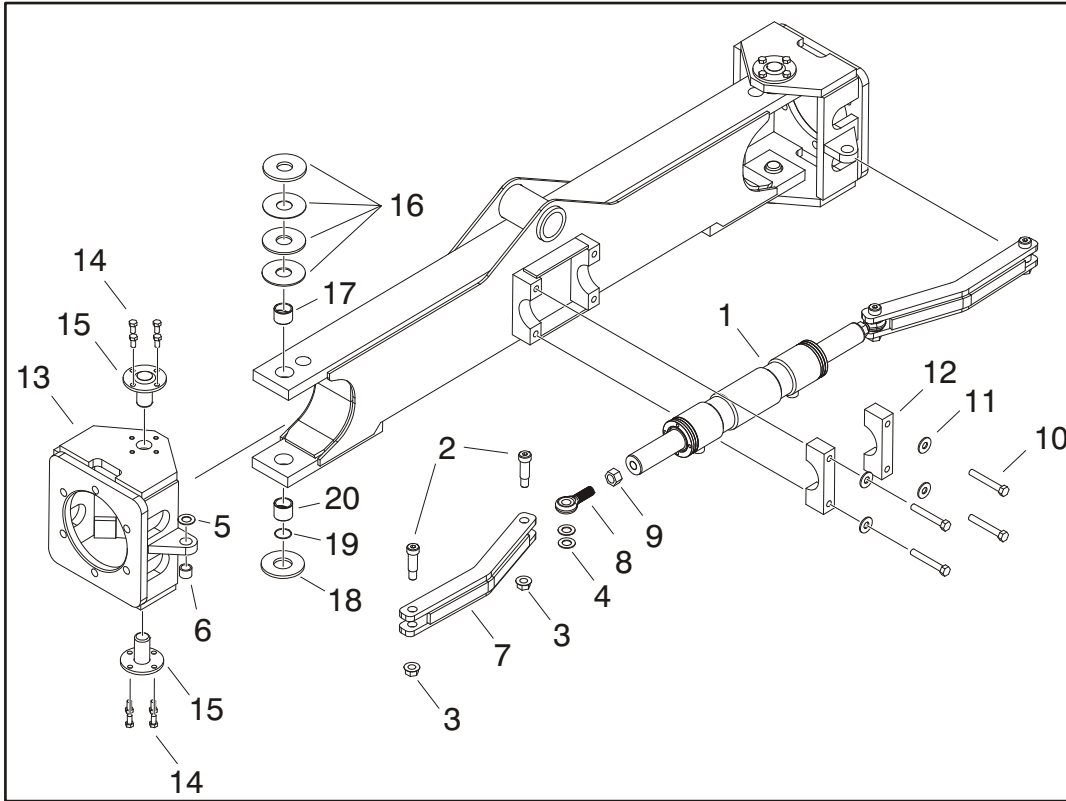

- | | | | |
|--------------------------|----------------------------|--------------------------|-------------------|
| 1. Steer Cylinder | 6. Bearing | 11. Washer | 16. Thrust Washer |
| 2. Screw, 3/4"D x 1 3/4" | 7. Tie Rod | 12. Cylinder Block | 17. Bearing |
| 3. Nut | 8. End Bearing Rod | 13. Spindle | 18. Thrust Washer |
| 4. Thrust Washer | 9. Nut | 14. Bolt, 3/8"-16 x 3/4" | 19. O-ring |
| 5. Thrust Washer | 10. Bolt, 1/2"-13 x 3 1/2" | 15. Kingpin | 20. Bearing |

Figure 3-32. Steering Assembly

STEER CYLINDER REMOVAL:

1. Disable machine operation and block all wheels. Disconnect, cap and label all hydraulic lines and electrical wiring on steer cylinder (1).
2. Support steer cylinder. Remove the screws (2), nuts (3) and thrust washers (4) connecting cylinder to tie rod (7). Remove end bearing rod (8) and nut (9) from cylinder.
3. Remove 4 bolts (10) and washers (11) connecting cylinder to axle. Carefully remove cylinder.

Spindle Removal:

1. Remove wheel and drive assembly prior to spindle (13) removal (refer to Figure 3-1., Drive Assembly (Bosch Rexroth)).

2. Support spindle. Disconnect tie rod (7) from spindle by removing bolt (2), nut (3) and thrust washer (5).
3. Remove spindle from axle by removing 8 bolts (14), 2 kingpins (15), 5 thrust washers (16, 18) and o-ring (19).

ASSEMBLY:

1. When assembling steer cylinder and spindle, follow Removal Steps in reverse.

NOTE: Apply Loctite® #242 to bolts (10, 14) and nut (3). Apply bearing grease lube to the grooves on the bearings (17, 20) before installing. Ensure thrust washer (5) is between tie rod (7) and top side of spindle (13). Refer to Figure 4-28., Steer Cylinder for steer cylinder breakdown.

Axle Assembly

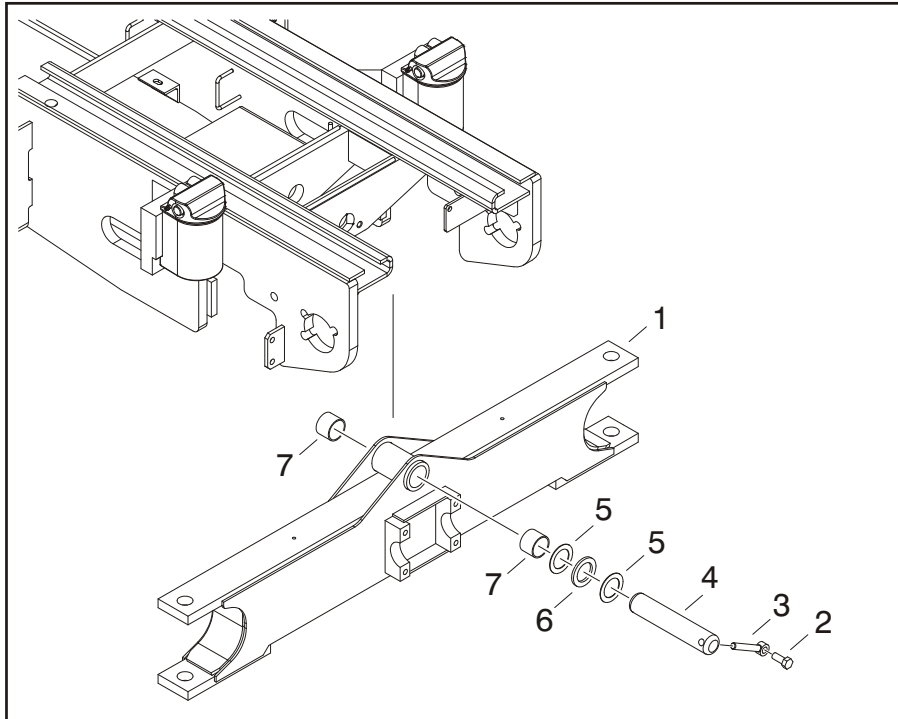

- | | | |
|-----------------------------|-----------------------|------------|
| 1. Front Axle | 4. Axle Pivot Pin | 7. Bearing |
| 2. Bolt, 5/8"-11NC x 1 1/2" | 5. Thrust Washer | |
| 3. Pin Keeper | 6. Thrust-Axle Washer | |

Figure 3-33. Axle Assembly

REMOVAL:



SUPPORT THE FRAME AND AXLE BEFORE ATTEMPTING ANY REMOVAL AND/OR ASSEMBLY PROCEDURES.

1. Disable machine operation. Remove wheel and drive assemblies (refer to Figure 3-1., Drive Assembly (Bosch Rexroth)).
2. Remove the bolt (2) and pin keeper (3).
3. Push the axle pivot pin (4) out and remove the thrust washers (5, 6) and bearings (7).
4. Axle can now be moved away from the frame.

ASSEMBLY:

1. When installing the axle assembly, follow Removal Steps in reverse.

NOTE: Apply Loctite® #271 to bolt (2).

Front Axle - Tow Bar Installation (If Equipped)

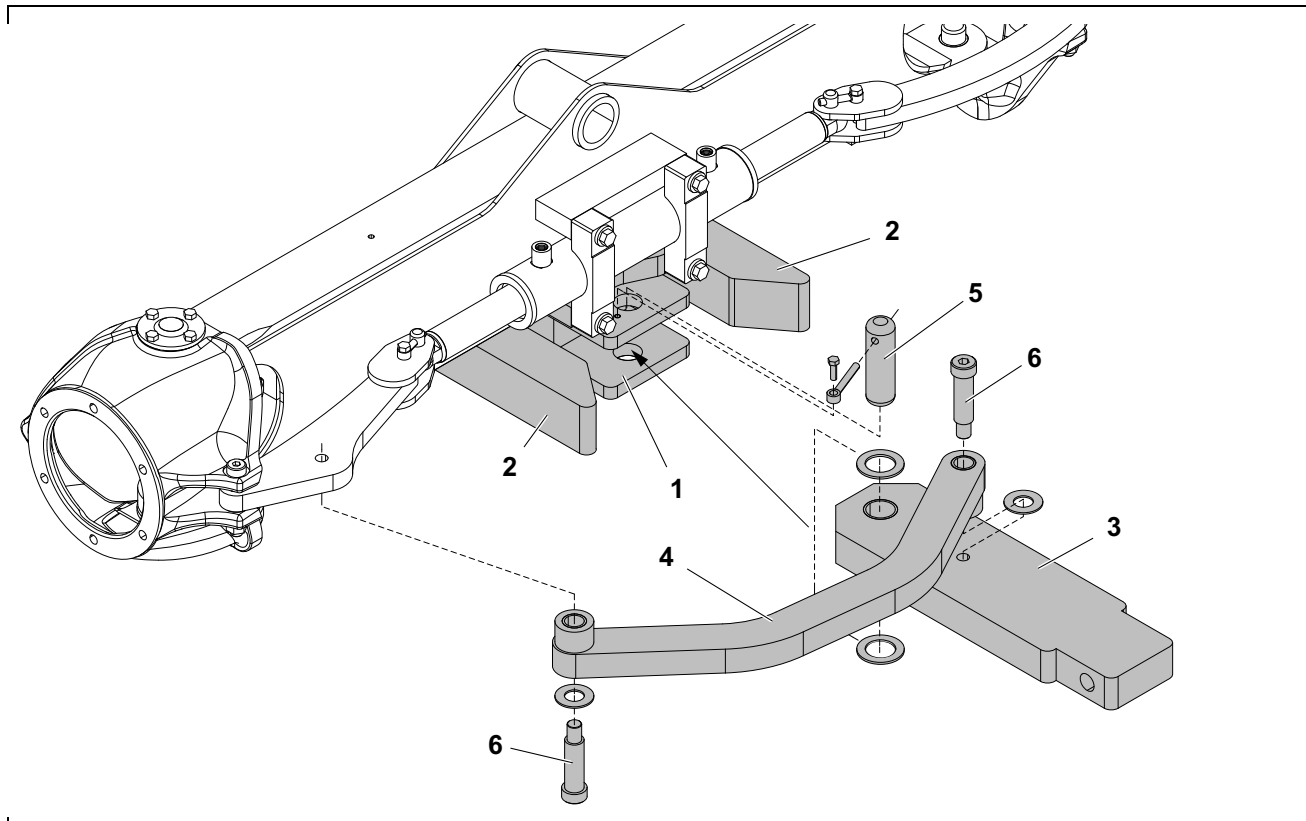

- | | |
|---------------------------|------------------------------------|
| 1. Tow Bar Axle Mount | 4. Steering Link |
| 2. Tow Bar Steering Stops | 5. Pivot Pin |
| 3. Tow Bar | 6. Tie Rod/Tow Bar Shoulder Screws |

Figure 3-34. Tow Bar Installation (If Equipped)

INSTALLATION:

NOTE: Before assembly coat all bearing, pin, thrust washers, and shoulder screw wear surfaces with a light coating of multi-purpose grease. Keep screw threads free of grease since thread locking compound will be used there.

1. Place the tow bar (3) into the axle mount (1) with a thrust washer on the top and bottom, aligned with the pivot pin hole.
2. Slide the tow bar pivot pin (5) down through the hole in the top axle mount weldment and through the tow bar and thrust washers, then into the lower axle mount weldment.
3. Fix the tow bar pivot pin into place by sliding the banjo locking pin through the hole in the pivot pin. Secure the banjo locking pin to the upper tow bar mount with the screw provided. Apply thread locking compound-(#242) to threads of screw, then tighten.
4. Install the steering link (4) to the tow bar (3) with the shoulder screw (6), placing a thrust washer between the steering link and the tow bar as shown above. Apply thread locking compound-(#242) to the shoulder screw (6) threads, then tighten.
5. Attach the other end of the steering link (4) to the axle tie rod assembly. Place a thrust washer under the head of the shoulder screw (6), apply thread locking compound-(#242) to the screw threads. Slide the screw and thrust washer into the steering link and align with the mounting hole in the tie rod assembly, tighten the screw.

If removal is required, tow bar can be completely removed by removing the pivot pin (5) and the tie rod - tow bar shoulder screw (6). Place all loose parts in a clean plastic bag for later use.

When re-installing repeat all steps except step (4) since this connection should not have required disassembly.

Axle Lockout Cylinder

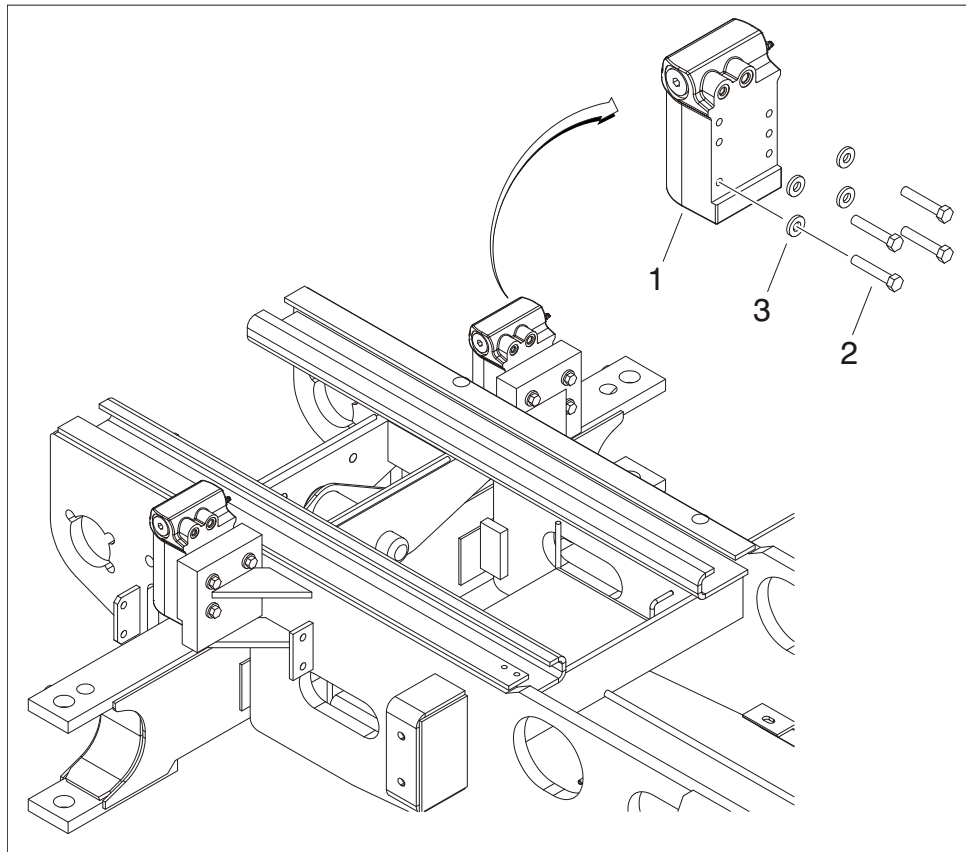

1. Axle Lockout Cylinder
2. Bolt, 1/2"-11NC x 2 3/4"
3. Washer

Figure 3-35. Axle Lockout Cylinder

REMOVAL:

1. Disable machine operation.
2. Disconnect, cap and label hydraulic lines on the axle lockout cylinder (1).
3. Remove the four bolts (2) and washers (3) connecting the cylinder to the frame.
4. Carefully remove cylinder from the frame.

INSTALLATION:

1. Attach cylinder to frame using four bolts (2) and washers (3).

NOTE: Apply Loctite® #242 and Loctite® Primer #7471 to bolts (2).

2. Uncap and reconnect hydraulic lines to cylinder.

NOTE: Refer to Section 4.13, Cylinder Assemblies for axle lockout cylinder breakdown and bleeding procedure.

3. Operate axle lockout cylinder function to ensure proper functioning.

3.7 LEVELING JACKS (IF EQUIPPED)

Cylinder Removal

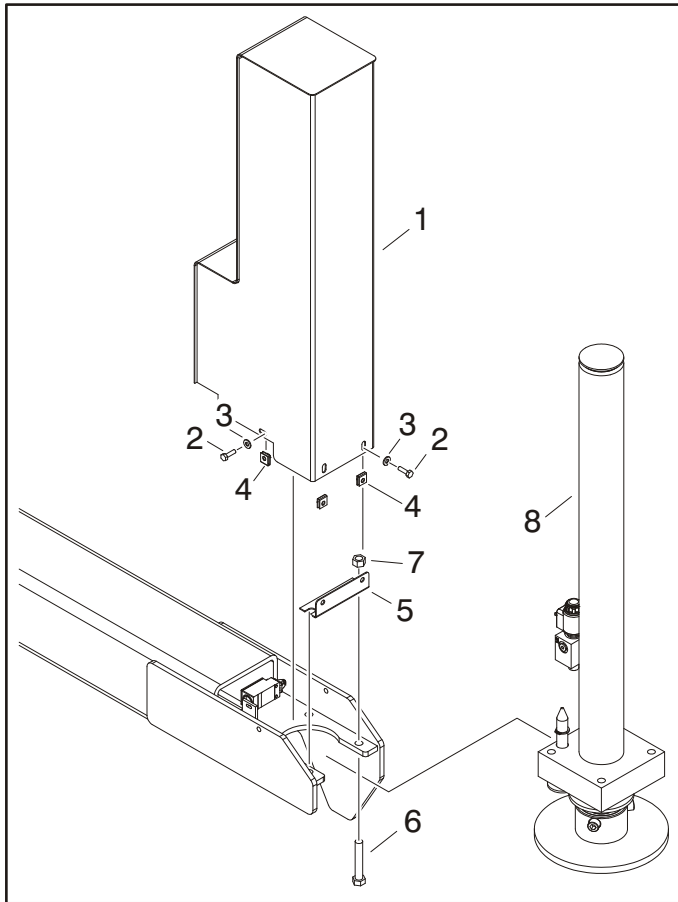

1. Cover
2. Bolt, 1/4"-20NC x 7/8"
3. Flatwasher
4. Tinnerman Nut
5. Jack Cover Bracket
6. Bolt, 1/2"-13NC x 3"
7. Nut
8. Leveling Jack Cylinder

Figure 3-35. Leveling Jack Cylinder Removal

REMOVAL:

1. Disable machine operation.
2. Remove the four bolts (2), flatwashers (3) and tinnerman nuts (4) from cover (1). Carefully lift cover up and off of machine.
3. Disconnect, cap and label all hydraulic lines and wires connected to the leveling jack cylinder (8).
4. Support cylinder. Remove the four bolts (6) and nuts (7) attaching cylinder to cylinder mount. Remove jack cover bracket (5).
5. Carefully remove cylinder from mount.

INSTALLATION:

1. Follow Removal Steps in reverse.

NOTE: Refer to Figure 4-32., Leveling Jack Cylinder for cylinder breakdown.

2. Operate leveling jacks to ensure proper operation.

Assembly Removal

NOTE: Applies to both front and rear of machine.

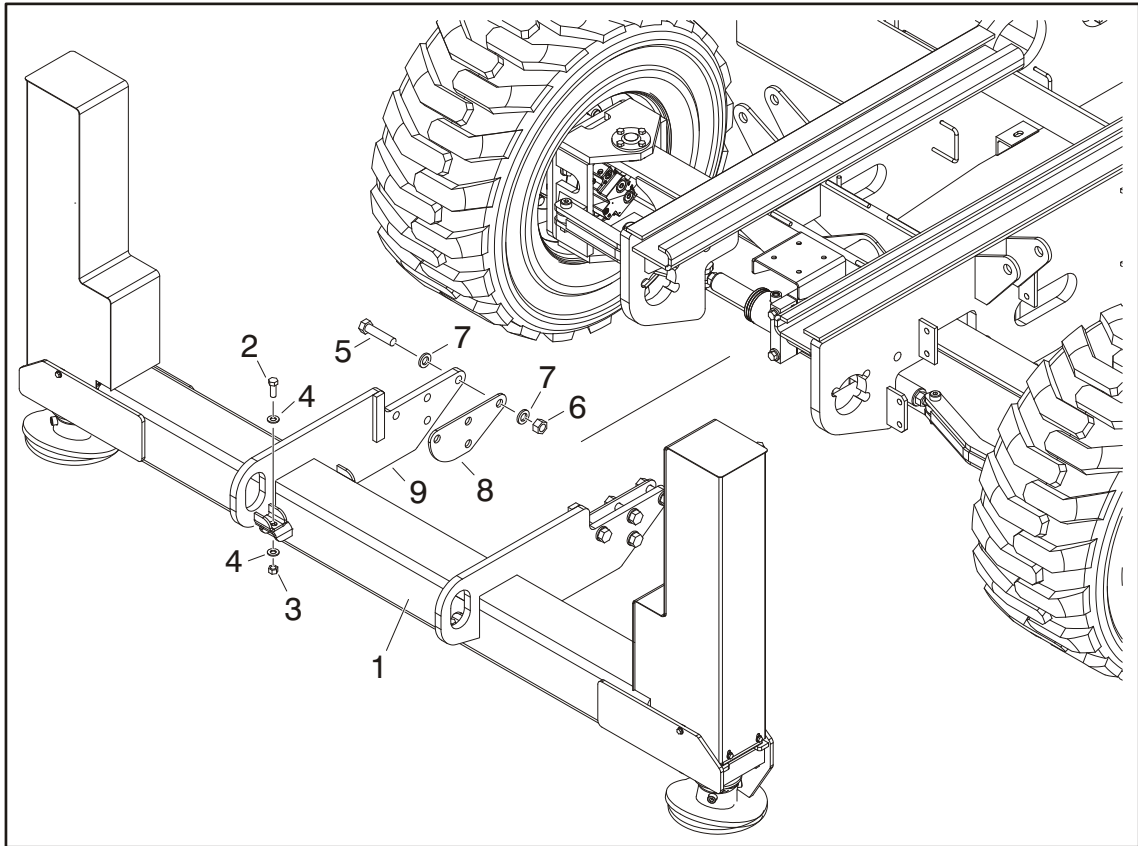

- | | | |
|-----------------------------|-------------------------------|------------|
| 1. Leveling Jacks Assembly | 4. Washer | 7. Washer |
| 2. Bolt, 1/2"-13NC x 1 3/8" | 5. Bolt, 3/4" - 10NC x 3 1/4" | 8. Plate |
| 3. Nut | 6. Nut | 9. Support |

Figure 3-36. Leveling Jacks Assembly

REMOVAL:

CAUTION

SUPPORT THE LEVELING JACKS ASSEMBLY BEFORE ATTEMPTING ANY REMOVAL AND/OR ASSEMBLY PROCEDURES.

1. Disable machine operation and block all wheels.
2. Remove covers from leveling jack cylinders (refer to Figure 3-35., Leveling Jack Cylinder Removal).
3. Disconnect, cap and label hydraulic lines connected to leveling jack cylinders. Disconnect and label all electrical wiring attached to cylinder and switches.
4. Remove the four bolts (2), nuts (3) and washers (4).

5. Carefully lower assembly from the supports (9).
6. Supports can be removed from chassis by removing the four bolts (5), nuts (6) and washers (7).

INSTALLATION:

1. Follow Removal Steps in reverse.

NOTE: Torque bolts (5) to 280 lb-ft (379.6 Nm).

2. Uncap and reconnect hydraulic lines and electrical wires to cylinders and switches.
3. Operate leveling jacks to ensure proper operation.

3.8 PLATFORM

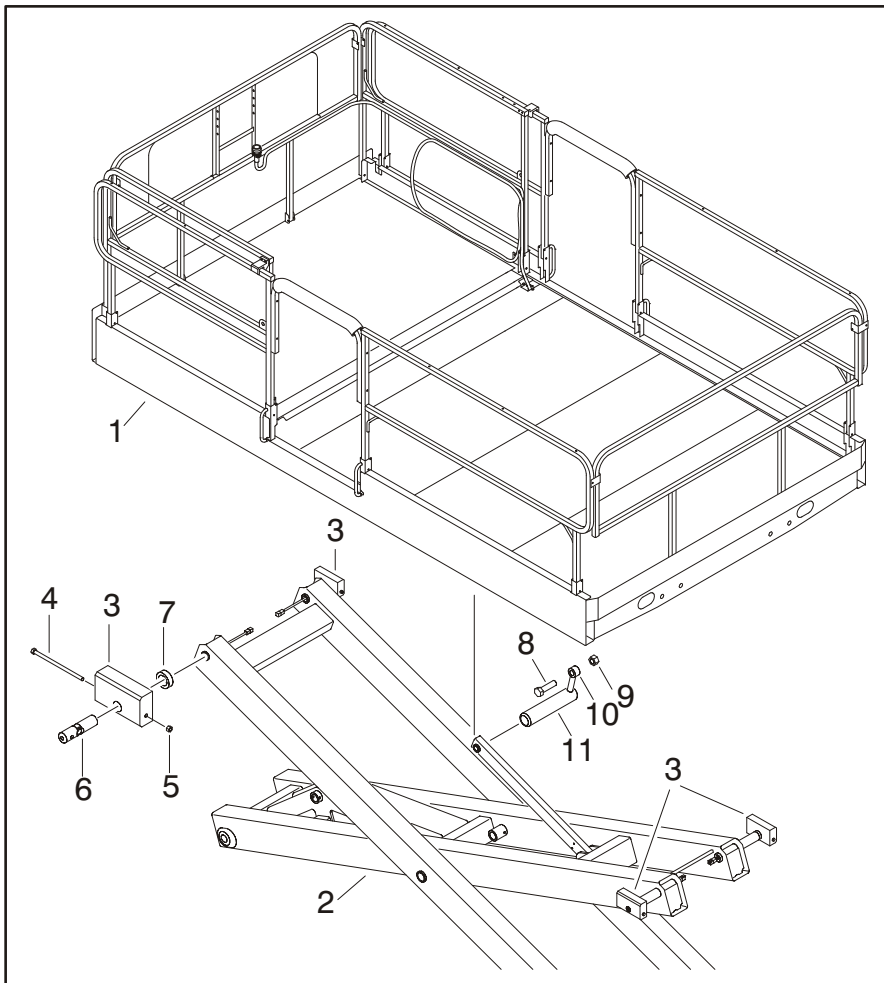

1. Platform
2. Scissor Arms
3. Slide Block
4. Bolt, (metric) 10 x 200
5. Locknut, (metric) M10 x 1.5
6. Pin
7. Spacer Tube
8. Bolt, 3/8"-16NC x 1 3/8"
9. Locknut
10. Pin Keeper
11. Pin

Figure 3-37. Platform Removal

⚠ CAUTION

NEVER WORK UNDER ELEVATED PLATFORM WITHOUT FIRST PROPERLY SUPPORTING THE PLATFORM AND BRACING/BLOCKING SCISSOR ARM ASSEMBLY.

REMOVAL:

1. Disable machine operation.
2. Place lifting straps at each end of the platform (1). Using an overhead crane lift platform.

NOTE: Use lifting straps and overhead crane capable of lifting at least 6000 lbs (2722 kg).

3. Disconnect, cap and label hydraulic lines on deck extension cylinders. Disconnect and label all electrical wires going to platform.

4. Detach the center attach link from the platform by removing the bolt (8), locknut (9) pin keeper (10) and pin (11).
5. With scissor arm assembly (2) braced, remove the slide block (3) at each corner of the platform by removing the bolt (4), locknut (5), pin (6) and spacer tube (7).
6. Lift platform away from the machine.

INSTALLATION:

1. Follow Removal Steps in reverse.

NOTE: For machines equipped with Load Sensing System, refer to JLG Supplement P/N 3124288.

NOTICE

TIGHTEN BOLTS (4) AND LOCKNUTS (5) TO JUST MAKE CONTACT WITH THE SLIDE BLOCKS (3). DO NOT OVERTIGHTEN.

Deck Extension Cylinders (if equipped)

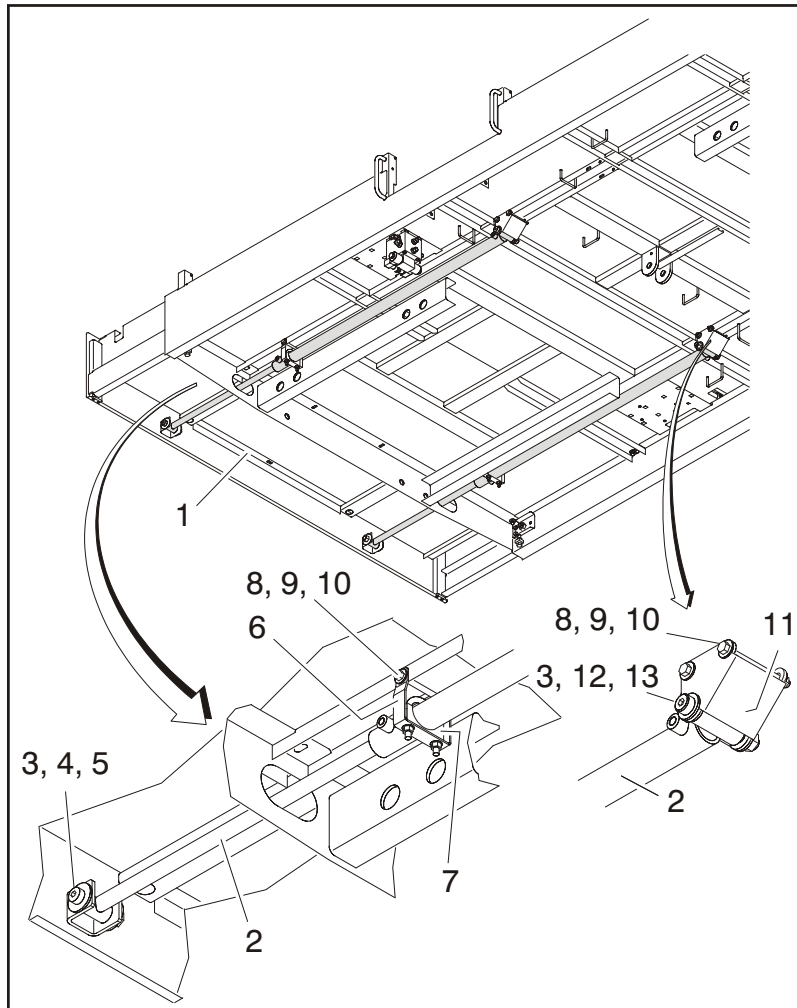

1. Platform & Deck Extension
2. Deck Extension Cylinders
3. Shoulder Screw
4. Flatwasher
5. Locknut, 5/8"-11NC
6. Hanger Bracket
7. Clamp
8. Bolt, 3/8"-16NC x 4 1/2"
9. Locknut, 3/8"-16NC
10. Flatwasher
11. Cylinder Attach Bracket
12. Shoulder Screw
13. Flatwasher

Figure 3-38. Deck Extension Cylinders Removal

REMOVAL:

NOTE: Each deck extension has two deck extension cylinders.

1. Disable machine operation.
2. Disconnect, cap and label hydraulic lines attached to extension cylinders (2). Disconnect and label any electrical wires attached to cylinders.
3. Support extension cylinders before disconnecting from bottom side of platform (1).
4. Remove the shoulder screws (3, 12), locknuts (5, 9), bolts (8) and flatwashers (4, 10, 13).
5. Carefully remove the extension cylinder.

INSTALLATION:

1. Follow Removal Steps in reverse.
2. Reconnect hydraulic lines to cylinder.
3. Operate deck extension function to ensure proper operation.

NOTE: Refer to Figure 4-34., Deck Extension Cylinder for cylinder breakdown.

Platform Control Station

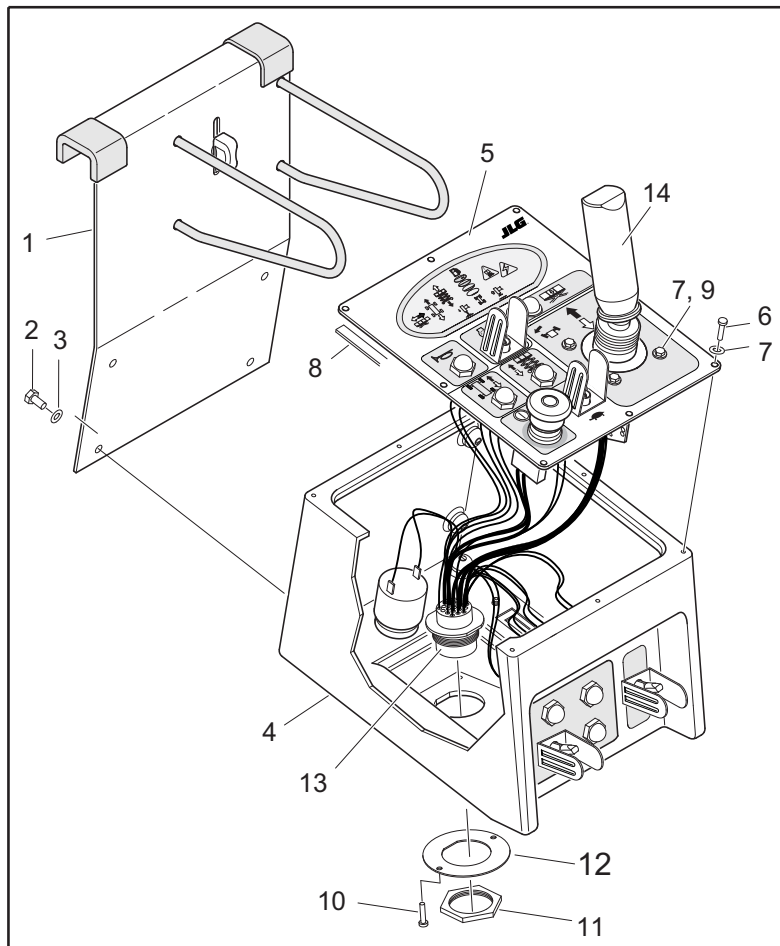

1. Mounting Bracket
2. Bolt, 1/4"-20NC x 1/2"
3. Starwasher
4. Console Box
5. Console Lid
6. Self Tapping Screw, #8-18 x 3/4"
7. Washer
8. Insulation Tape
9. Plastite Screw, #10-32NC x 1/2"
10. Self Tapping Screw, #8-18 x 3/4"
11. Terminal Nut
12. D-Ring Bracket
13. Harness
14. Joystick Controller

Figure 3-39. Platform Control Station

DISASSEMBLY:

1. Disconnect the cable from the harness on the underside of the platform control station.
2. Remove the control station from the mounting bracket (1) by removing the four bolts (2) and starwashers (3).
3. Remove the seven screws (6) and washers (7) to remove the console lid (5) from the console box (4).
4. Once lid is removed, switches, buttons and bulbs can be removed for replacement.
5. Remove the the four screws (7) and washers (9) to remove the joystick controller (14).
6. The harness (13) can be removed from the box by removing the terminal nut (11), two screws (10) and d-ring bracket.

ASSEMBLY

1. Follow Disassembly Procedures in reverse.
2. Ensure electrical wires are properly and securely attached to switches, buttons and bulbs.
3. Apply a new layer of insulation tape (8) between lid and box if needed.

NOTE: Ensure wires are not pinched when placing lid onto box.

4. Reattach cable to harness on underside of platform control station.
5. Operate functions with platform control console to ensure proper operation.

Joystick Controller

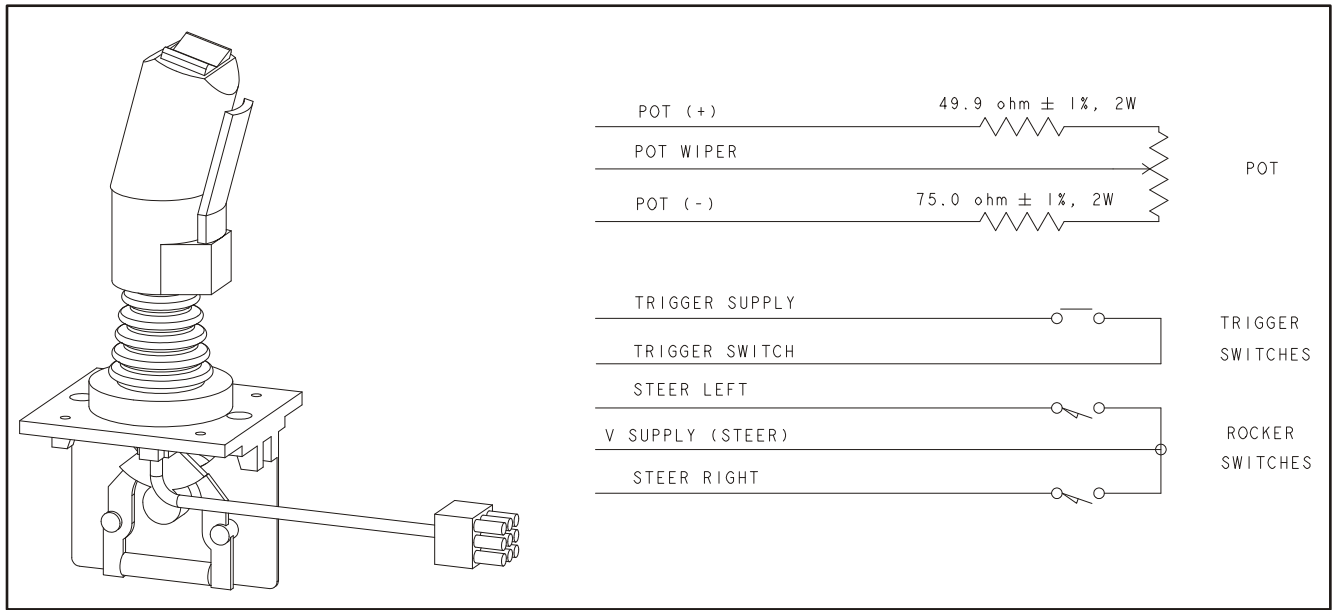

Figure 3-40. Joystick Controller

Table 3-11. Joystick Specifications

Input Voltage	5V
Centered Output Voltage	4.25V to 2.60V
Reverse Voltage	4.60V to 4.80V
Forward Voltage	0.40V to 0.60V

Table 3-12. Joystick Plug Loading Chart

Terminal	Color	Function
1	Yellow	Steer Right
2	Green	Steer Left
3	Brown	Pot Wiper
4	Red	Handle Common
5	N/A	Not Connected
6	White/Red	Pot (+)
7	Violet	Trigger Switch
8	Blue	Trigger Supply
9	White/Black	Pot (-)

3.9 SCISSOR ARMS

Lift Cylinder Removal

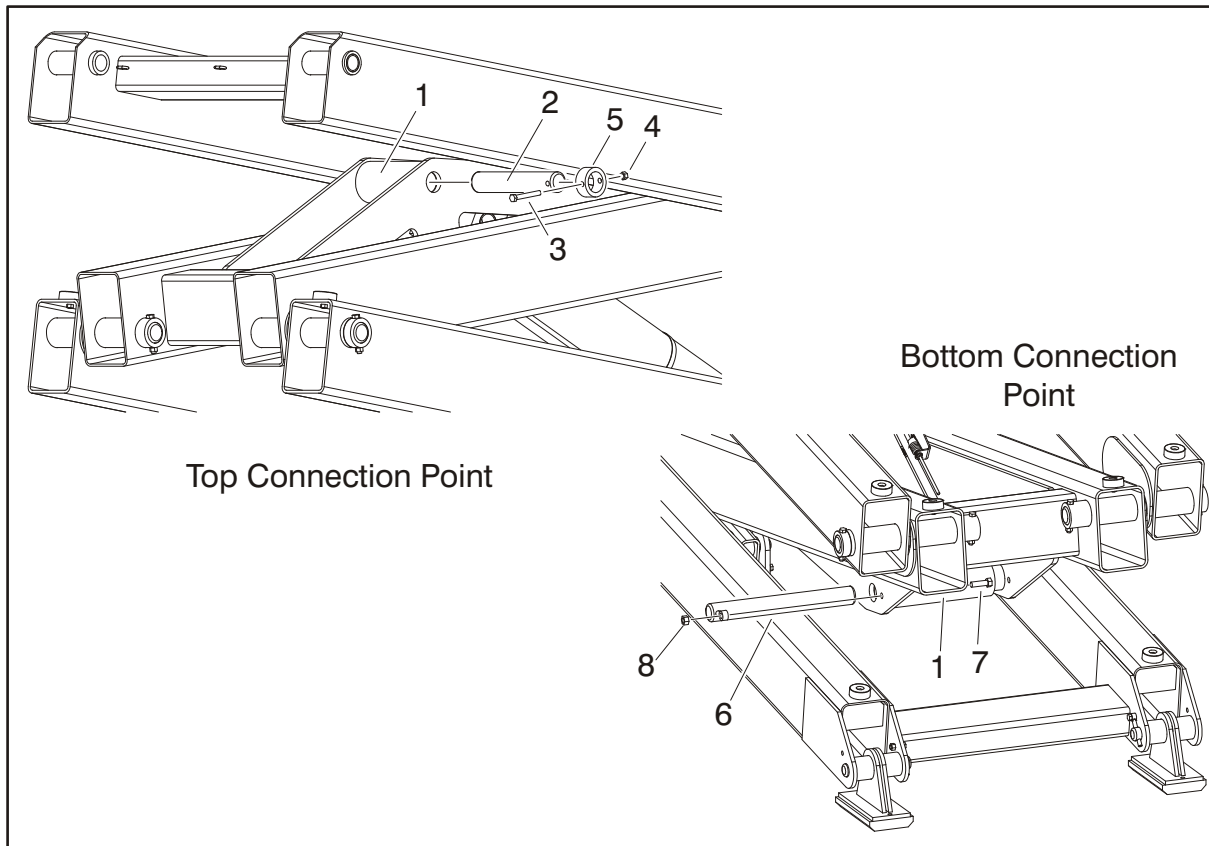

- | | | |
|-------------------------|-----------|-----------------------------|
| 1. Lift Cylinder | 4. Nut | 7. Bolt, 1/2"-13NC x 1 5/8" |
| 2. Pin | 5. Collar | 8. Nut |
| 3. Bolt, 3/8"-16NC x 3" | 6. Pin | |

Figure 3-41. Lift Cylinder Removal

REMOVAL:

CAUTION

NEVER WORK UNDER ELEVATED SCISSOR ARMS WITHOUT FIRST PROPERLY BRACING/BLOCKING SCISSOR ARM ASSEMBLY.

1. Remove platform (refer to Figure 3-37.).
2. Elevate the scissor arm assembly enough to gain access to the upper and lower connection pins (2, 6). Block/brace scissor arms and disable machine.
3. Disconnect, cap and label all hydraulic lines connected to lift cylinder (1). Disconnect and label all electrical wires connected to lift cylinder.

4. Attach lifting straps to overhead crane and lift cylinder and support cylinder before attempting to remove from arm assembly.
5. Remove the upper pin (2) by removing the bolt (3), nut (4) and collar (5). Push pin out.
6. Remove the lower pin (6) by removing the bolt (7) and nut (8). Push pin out.
7. Carefully lift cylinder up and out of arm assembly.

INSTALLATION:

1. Follow Removal Steps in reverse.
2. After assembly, operate lift cylinder to ensure proper operation.

NOTE: Refer to Figure 4-29., *Lift Cylinder* for cylinder breakdown.

Scissor Arms Removal

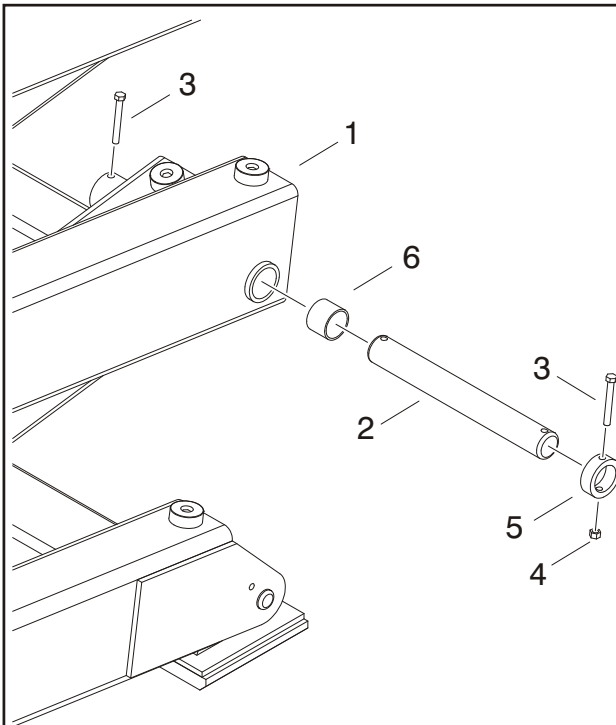

- | | |
|-------------------------|------------|
| 1. Scissor Arm | 4. Nut |
| 2. Pin | 5. Collar |
| 3. Bolt, 3/8"-16NC x 3" | 6. Bearing |

Figure 3-42. Scissor Arms Removal

CAUTION

NEVER WORK UNDER ELEVATED SCISSOR ARMS WITHOUT FIRST PROPERLY BRACING/BLOCKING SCISSOR ARM ASSEMBLY.

NOTE: Scissor arms can be removed individually or as an entire assembly.

ARM REMOVAL:

1. Remove platform (refer to Figure 3-37.) and lift cylinder (refer to Figure 3-41.).
2. Disconnect, cap and label all hydraulic hoses and wiring attached to scissor arms.
3. Support the scissor arm(s) being removed.
4. Remove the pin (2) from the scissor arm (1) by removing the two bolts (3), nuts (4) and collar (5).
5. Push pin and bearing (6) out from scissor arms.
6. Repeat at each connecting pin.

INSTALLATION:

1. Follow Removal Steps in reverse.

Scissor Arm Assembly Removal

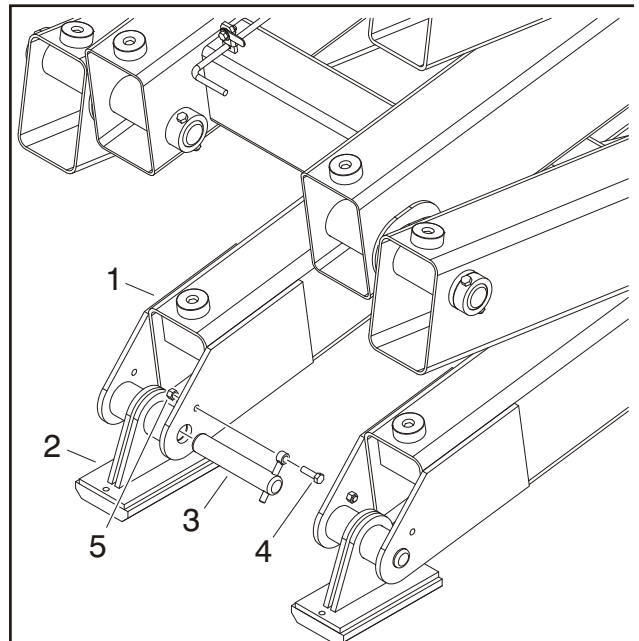

- | | |
|----------------|-----------------------------|
| 1. Scissor Arm | 4. Bolt, 3/8"-16NC x 1 1/4" |
| 2. Slider | 5. Nut |
| 3. Pin | |

Figure 3-43. Scissor Assembly Removal - Chassis Connection

CAUTION

NEVER WORK UNDER ELEVATED SCISSOR ARMS WITHOUT FIRST PROPERLY BRACING/BLOCKING SCISSOR ARM ASSEMBLY.

REMOVAL:

NOTE: Applies to all four corners.

1. Remove platform (refer to Figure 3-37., Platform Removal).
2. Disconnect, cap and label all hydraulic hoses and wiring attached to scissor arms and lift cylinder.
3. Support the scissor arm assembly with appropriate lifting straps and overhead crane.
4. Disconnect the scissor arm assembly from the four sliders (2) by removing the bolts (4) and nuts (5)
5. Push pins (3) out.
6. Carefully lift arm assembly up and away from chassis.

INSTALLATION:

1. Follow Removal Steps in reverse.

3.10 SIDE COMPARTMENT COVERS

REMOVAL:

Front:

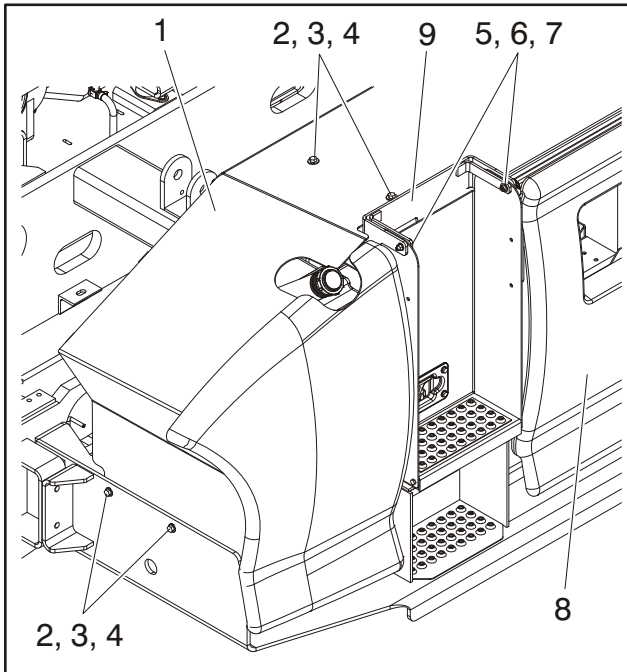

- | | |
|-----------------------------|------------|
| 1. Compartment Cover | 6. Washer |
| 2. Bolt, 3/8"-16NC x 1 1/8" | 7. Nut |
| 3. Washer | 8. Hood |
| 4. Nut | 9. Bracket |
| 5. Screw, 3/8" x 1" | |

NOTE: Procedures apply to both left and right side compartment hoods.

1. Elevate the platform to a height where, when removed and lifted, the compartment covers (1) clear the underside of the platform. Engage the arm safety prop and/or block the scissor arms to prevent lowering.
2. Disable machine operation.
3. Attach lifting straps to each end of the hood and support with an overhead lifting device.
4. Remove the four bolts (2), washers (3) and nuts (4) from the front and top of the cover.

NOTE: On engine side only, remove the exhaust tail pipe from the cover by removing the bolts, washers, and nuts.

5. Disconnect the the ladder from the bracket (9) by removing the two screws (5) washers (6) and nuts (7).

Inside:

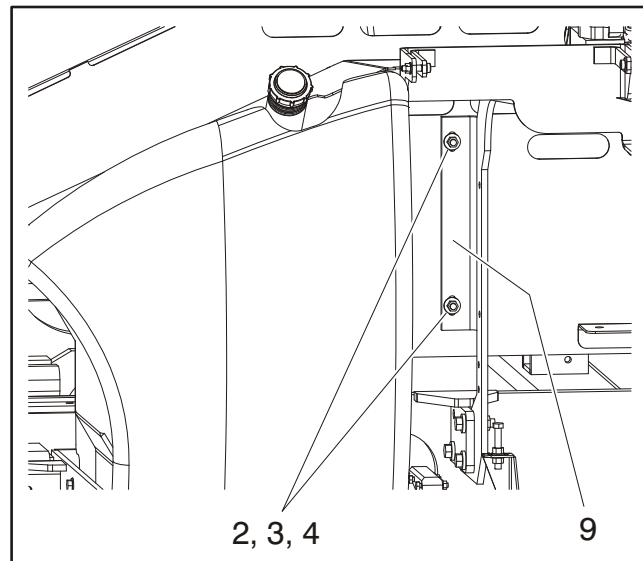

6. Open the hood (8).
7. Remove the two bolts (2), washers (3) and nuts (4) attaching the cover to the bracket (9).

Rear:

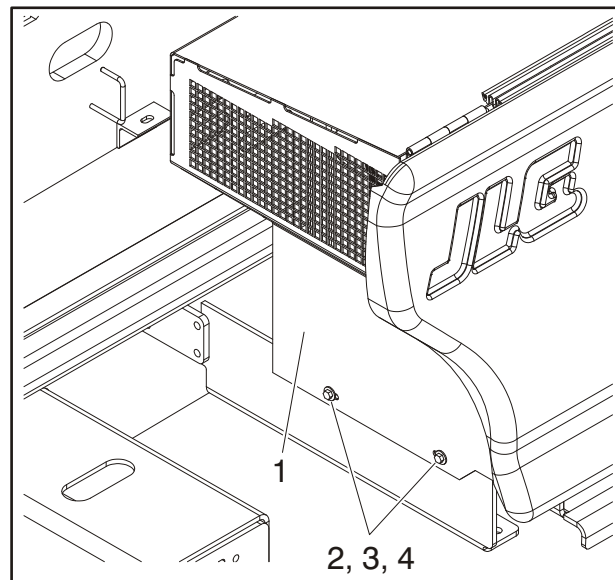

8. Remove the two bolts (2), washers (3) and nuts (4) from the rear of the cover.
9. Carefully lift the cover up and away from the machine.
10. Remove the bolts on the two hinges (not shown) and detach the gas springs to remove the hood from the cover (not shown).

INSTALLATION:

1. Follow Removal Steps in reverse.

3.11 GROUND CONTROL STATION

Control Station Removal

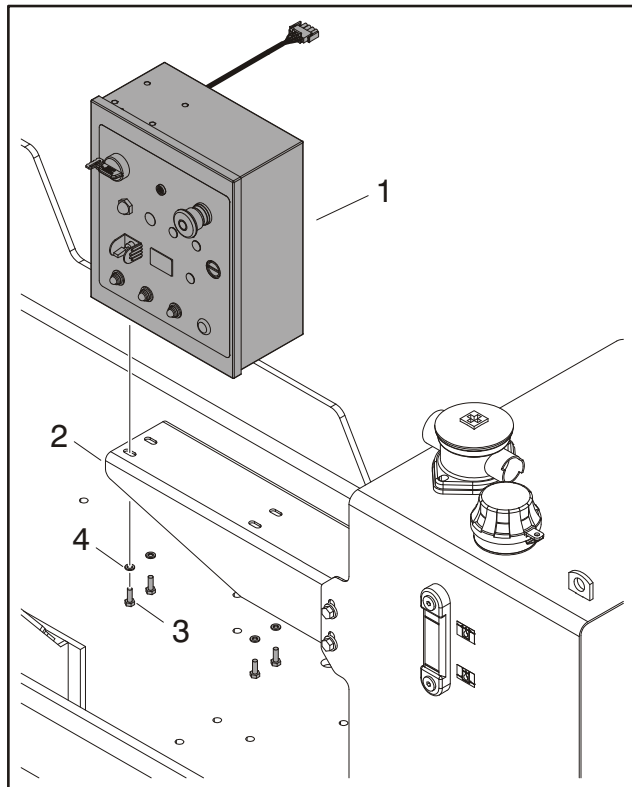

- | | |
|-----------------------|---------------------------|
| 1. Ground Control Box | 3. Bolt, 1/4"-20NC x 3/4" |
| 2. Control Box Mount | 4. Lockwasher |

Figure 3-44. Ground Control Station Removal

REMOVAL:

1. Disconnect and label the harnesses from the ground control box (1).
2. Remove the ground control box from the control box mount (2) by removing the four bolts (3) and lockwashers (4).

INSTALLATION:

1. Follow Removal Steps in reverse.

NOTE: Apply Loctite® #242 to the four bolts (3).

Ground Control Station

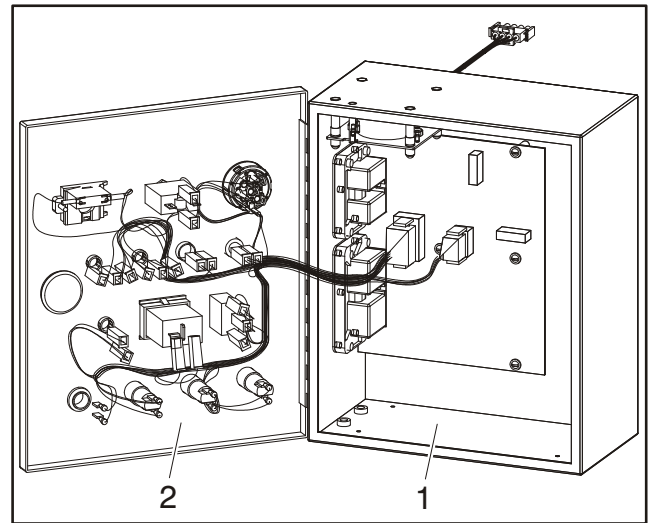

- | | |
|-----------------------|--------|
| 1. Ground Control Box | 2. Lid |
|-----------------------|--------|

Figure 3-45. Ground Control Station

DISASSEMBLY:

1. Disconnect the harnesses from the ground control box (1).
2. Open the lid (2) to gain access to components inside the ground control box.
3. Disconnect any wires and/or plugs from damaged components.
4. Remove and replace components if necessary.

ASSEMBLY:

1. Reattach any wires and/or plugs.
2. Close lid (2) and secure.
3. Reattach harnesses to the ground control box (1).

NOTE: If tilt sensor is removed and replaced, it must be calibrated (refer to Section 5.2, Calibrations).

3.12 FUEL TANK

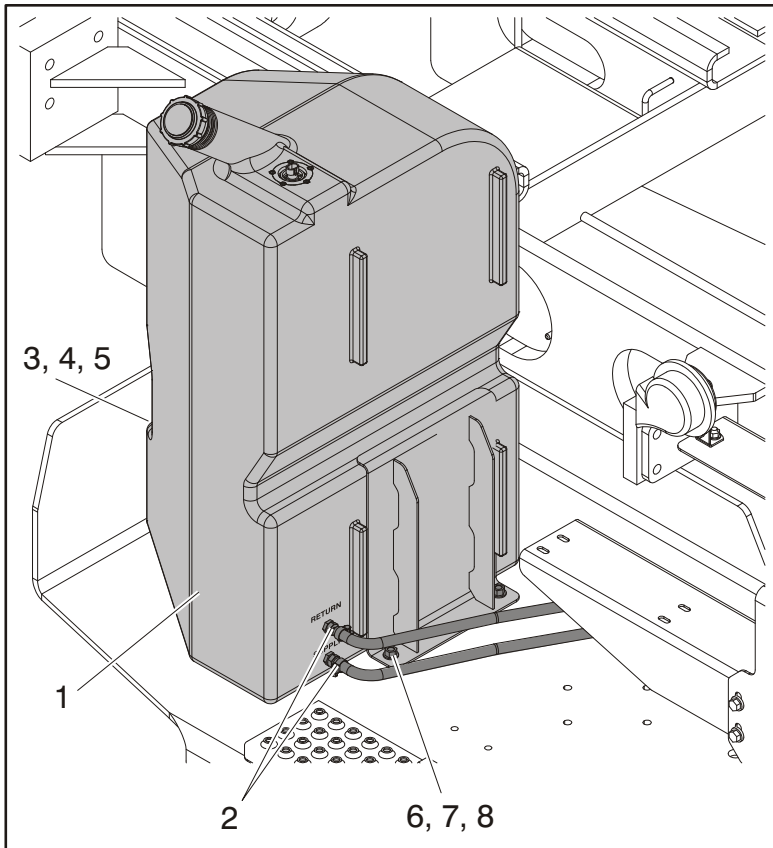

1. Fuel Tank
2. Fuel Lines
3. Bolt, 3/8"-16NC x 1 1/8"
4. Washer
5. Nut
6. Bolt, 3/8"-16NC x 1"
7. Washer
8. Nut

Figure 3-46. Fuel Tank Removal

REMOVAL:

1. Disable machine operation.
2. Drain fuel from the fuel tank (1). Store fuel in appropriate receptacle.
3. Disconnect and cap the two fuel lines (2) attached to the fuel tank.
4. Remove the bolts (3), washers (4) and nuts (5) from the bracket on the backside of the fuel tank.
5. Remove the bolts (6), washers (7) and nuts (8) from the bracket on the frontside of the fuel tank.
6. Remove the fuel tank from the hydraulic compartment.

INSTALLATION:

1. Follow Removal Steps in reverse.

NOTE: Apply pipe sealant (Loctite® #80724) to fuel line (2) fittings on the fuel tank (1).
Torque fuel line fittings to 12 lb-ft (16.3 Nm).

2. Refill fuel tank with proper fuel.

NOTICE

ENSURE PROPER FUEL LINES ARE ATTACHED TO PROPER FITTING ON FUEL TANK. FUEL TANK IS LABELED WITH RETURN LINE AND SUPPLY LINE.

3. Ensure there is no fuel leakage.

3.13 HYDRAULIC TANK

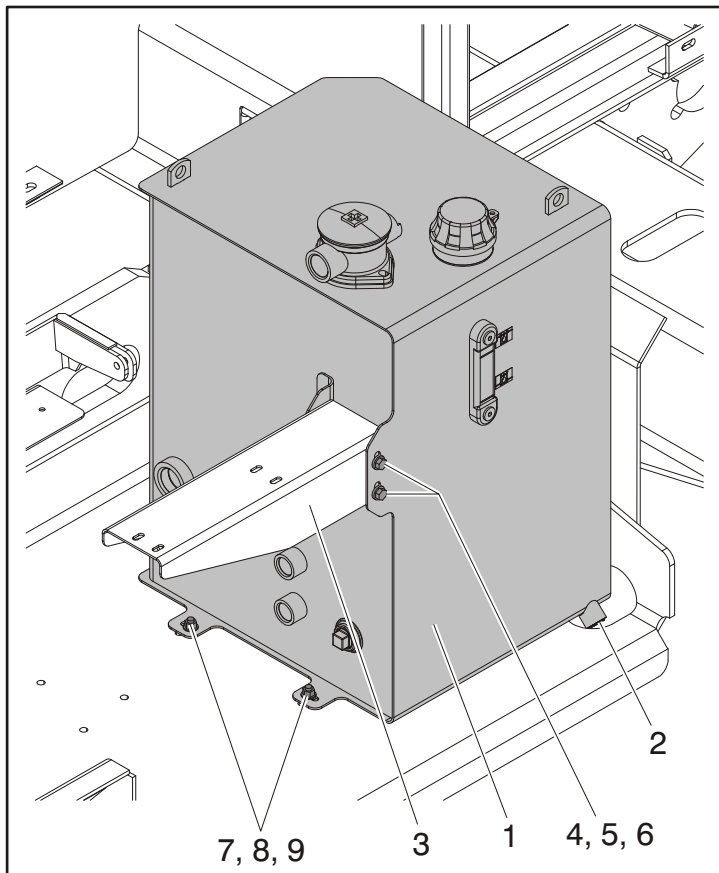

1. Hydraulic Tank
2. Drain Plug
3. Ground Control Box Mount
4. Bolt, 3/8"-16NC x 1"
5. Washer
6. Nut
7. Bolt, 3/8"-16NC x 1 1/8"
8. Washer
9. Nut

Figure 3-47. Hydraulic Tank Removal

REMOVAL:

NOTE: It is recommended to remove the side compartment cover before attempting to remove the hydraulic tank (refer to Section 3.10, Side Compartment Covers).

1. Disable machine operation.
2. Drain hydraulic fluid from hydraulic tank (1) by opening the drain plug (2). Store hydraulic fluid in appropriate receptacle.
3. Disconnect, cap and label all hoses connected to tank.
4. Remove the ground control box (not shown) (refer to Figure 3-44., Ground Control Station Removal) and ground control box mount (3) from the tank by removing the four bolts (4) washers (5) and nuts (6).
5. Remove the two bolts (7), washers (8) and nuts (9) attaching the hydraulic tank to the machine. Remove tank from machine.

NOTE: Hydraulic tank has two lifting lugs on the top corners for lifting.

Empty tank weighs approximately 105 lbs (47.6 kg).

INSTALLATION:

1. Follow Removal Steps in reverse.
2. Ensure drain plug (2) is closed. Refill hydraulic tank (1) with 34 gal (128.7 ltr) hydraulic fluid.

3.14 BATTERY

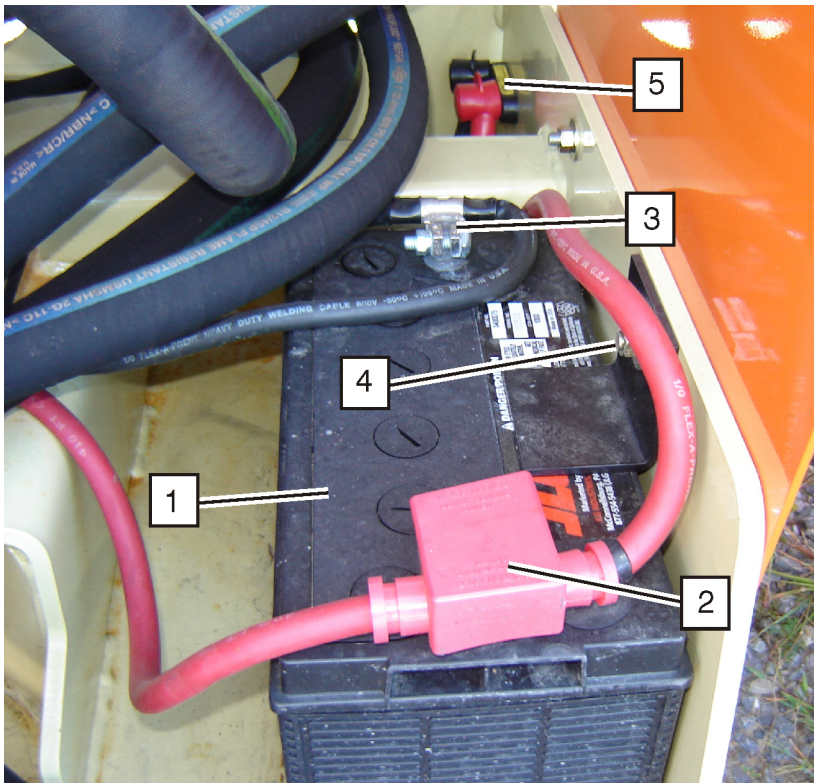

1. Battery
2. Battery Terminal (+)
3. Battery Terminal (-)
4. Bracket, Bolt, Nut & Washers
5. Fuse Mounting Block

Figure 3-48. Battery Removal

REMOVAL:

1. Disconnect the red battery cable from the positive battery terminal (2).
2. Disconnect the black battery cable from the negative battery terminal.
3. Remove the bolt, nut, and washers (4) to remove the bracket securing the battery in place. Remove battery.
4. The fuse mounting block (5) can be removed by first disconnecting the cables. Remove the bolts, washers and nuts securing the fuse block to the machine.

INSTALLATION:

1. Place battery in the seat. Positive battery terminal (2) should be closest to outside of machine.
2. Secure battery in place with bracket, bolt, nut and washers (4).
3. Reconnect red battery cable to positive battery terminal (2). Secure terminal cover in place over terminal.
4. Reconnect black battery cable to negative battery terminal (3).
5. Secure fuse mounting block (5) to machine using two bolts, nuts and washers. Reconnect cables.

3.15 DUAL FUEL/LPG SYSTEM

CAUTION

IT IS POSSIBLE TO SWITCH FROM ONE FUEL SOURCE TO THE OTHER WITHOUT ALLOWING THE ENGINE TO STOP. THE FOLLOWING INSTRUCTIONS MUST BE FOLLOWED.

Changing From Gasoline to LP Gas

NOTE: Before climbing onto the platform, open hand valve on LP gas supply tank by turning valve counter-clockwise.

1. Start engine from platform control station.
2. While engine is operating, place the dual fuel switch at platform control station to the LPG position. Allow engine to operate, without load, until engine begins to “stumble” from lack of gasoline. At this time the machine is allowing the LP fuel to be sent to the fuel regulator.

Changing From LP Gas to Gasoline

1. With engine operating on LP under a no-load condition, throw LPG/GASOLINE switch at platform control station to GASOLINE position.
2. If engine “stumbles” because of lack of gasoline, place switch to LPG position until engine regains smoothness, then return switch to GASOLINE position.
3. Close hand valve on LP gas supply by turning clockwise.

Using Liquid Petroleum (LP) Gas

WARNING

CLOSE FUEL VALVE ON TANK WHEN PARKING SIZZOR LIFT MORE THAN MOMENTARILY.

WHEN REFUELING LPG POWERED SIZZOR LIFTS, ALWAYS FOLLOW MANUFACTURERS SPECIFICATIONS AND/OR APPLICABLE REGULATIONS.

1. If machine is to be left overnight or longer, it must be parked outside or the LPG tank removed and stored outside.
2. LPG is extremely flammable. No smoking.
3. Only trained and authorized personnel are permitted to operate filling equipment.
4. Fill LPG tanks outdoors. Stay at least 50 ft (15 m) from buildings, motor vehicles, electrical equipment or other ignition sources. Stay at least 15 ft (5 m) from LPG storage tanks.
5. During transfer of LPG, metal components can become very cold. Always wear gloves when refilling or changing tanks to prevent “freeze burns” to skin.
6. Do not store LPG tanks near heat or open flame. For complete instructions on the storage of LPG fuels, refer to ANSI/NFPA 58 & 505 or applicable standards.

WARNING

DO NOT USE AN LPG TANK THAT IS DAMAGED. A DAMAGED TANK MUST BE REMOVED FROM SERVICE. FROST ON THE SURFACE OF A TANK, VALVES, OR FITTINGS INDICATES LEAKAGE. A STRONG ODOR OF LPG FUEL CAN INDICATE A LEAK.

3.16 DEUTZ ENGINE

Engine Tray

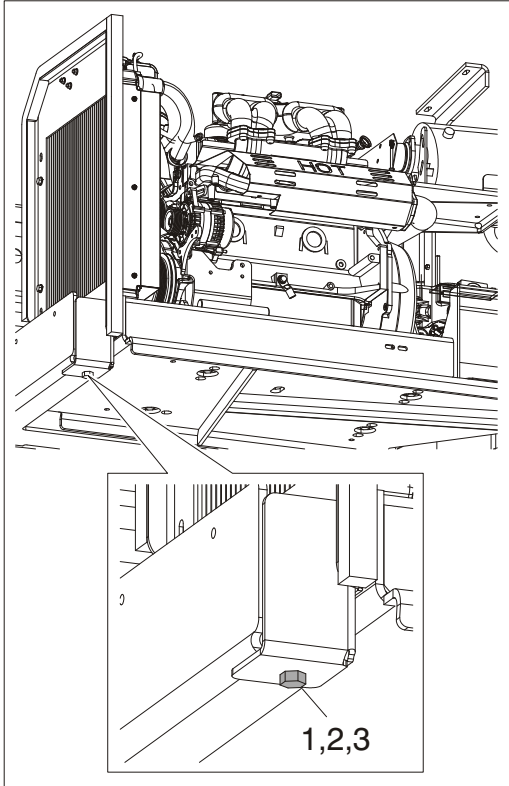

- 1. Bolt, 5/8"-11NC x 2" 3. Washer
- 2. Nut

NOTE: When servicing the engine and components, remove the bolt (1), nut (2) and washer (3) to swing the engine tray out for better access (as shown below).



Figure 3-49. Engine Tray Swing

Deutz EMR 2

The EMR2 consists of the sensors, the control unit and the actuator. Engine-side controls as well as the JLG Control System are connected by means of separate cable harnesses to the EMR control unit.

The sensors attached to the engine provide the electronics in the control unit with all the relevant physical parameters. In accordance with the information of the current condition of the engine and the preconditions (throttle position etc.), the EMR2 controls an actuator that operates the control rod of the injection pump and thus doses the fuel quantity in accordance with the performance requirements.

The exact position of the regulating rod is reported back and, if necessary, is corrected, by means of the control rod travel sensor, situated together with the rotation magnets in a housing of the actuator.

The EMR2 is equipped with safety devices and measures in the hardware and software in order to ensure emergency running (Limp home) functions.

In order to switch the engine off, the EMR2 is switched in a de-energized fashion over the ignition switch. A strong spring in the actuator presses the control rod in the de-energized condition into the zero position. As a redundancy measure, an additional solenoid serves for switching off and this, independently of the actuator, also moves the control rod in the de-energized condition into the zero position.

After the programming, that is carried out over the ISO9141 interface, the EMR2 possesses a motor-specific data set and this is then fixedly assigned to the engine. Included in this are the various application cases as well as the customer's wishes regarding a particular scope of function.

Each EMR2 module is matched by serial number to the engine. Modules cannot be swapped between engines.

Deutz EMR 4

Refer to Deutz Engine Manual (3123893) supplied with the machine for engine servicing and troubleshooting information.

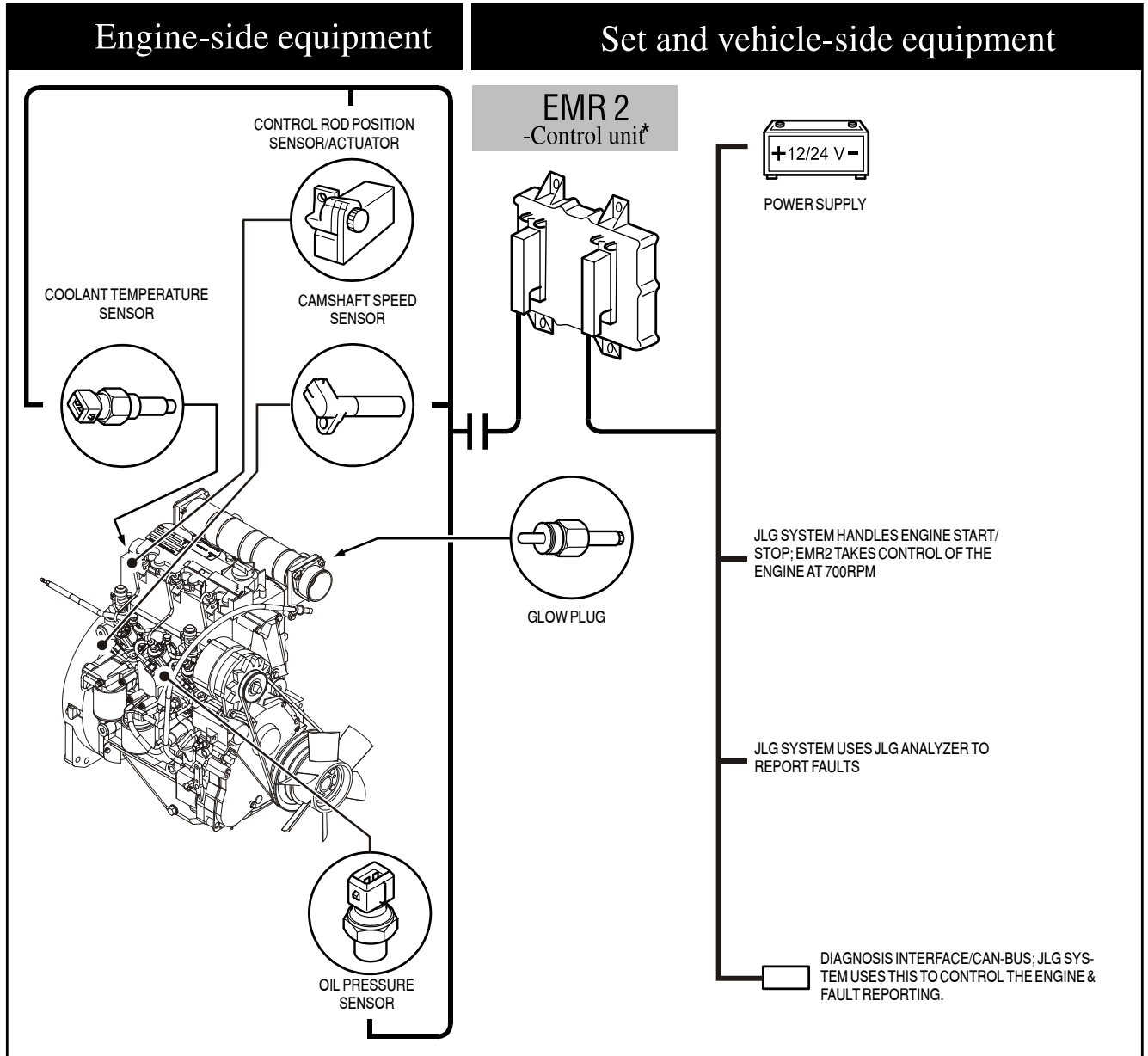

Figure 3-50. EMR 2 Engine Side Equipment

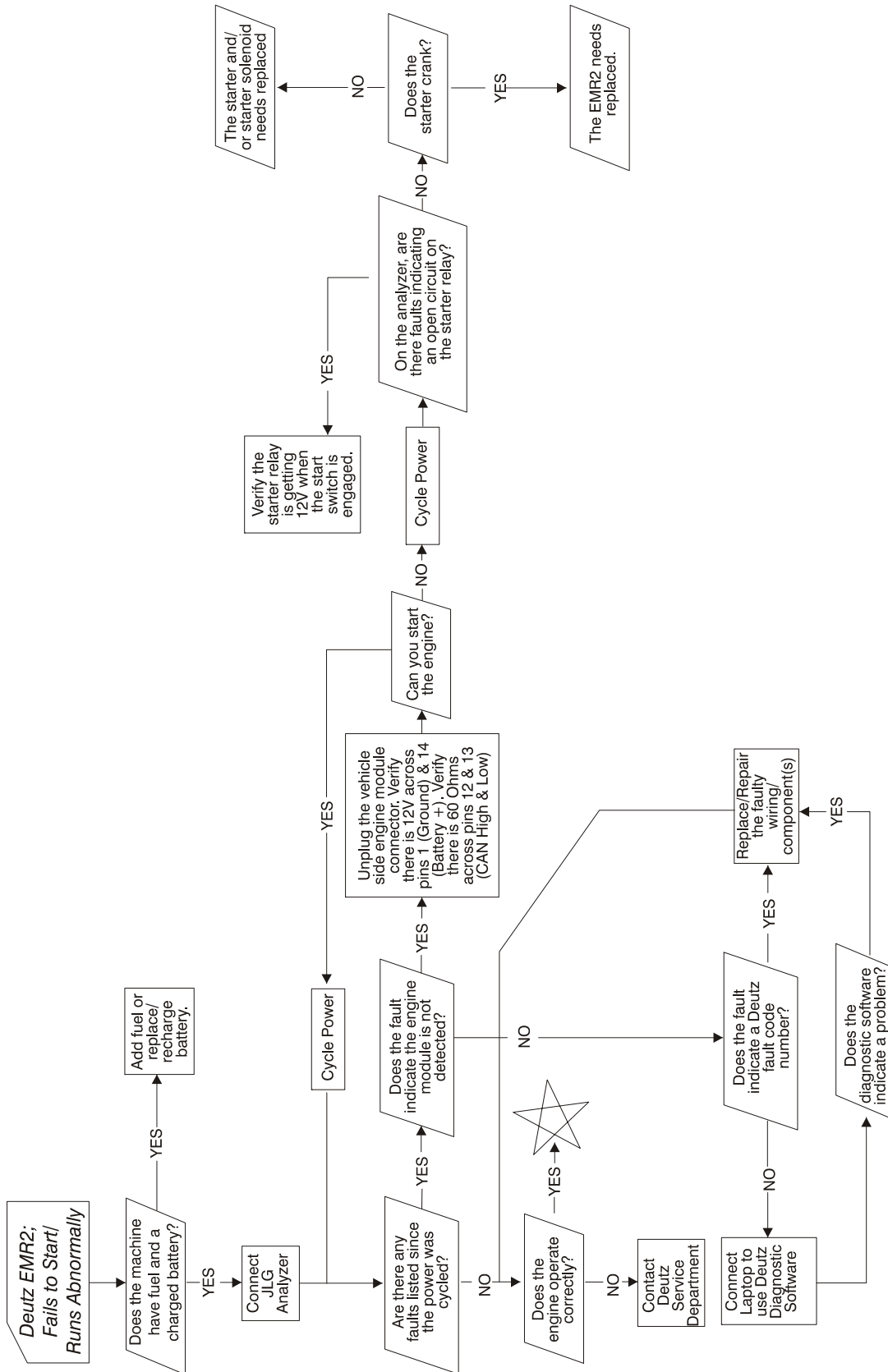

Figure 3-51. Deutz EMR 2 Troubleshooting Flow Chart

SECTION 3 - CHASSIS, PLATFORM & SCISSOR ARMS

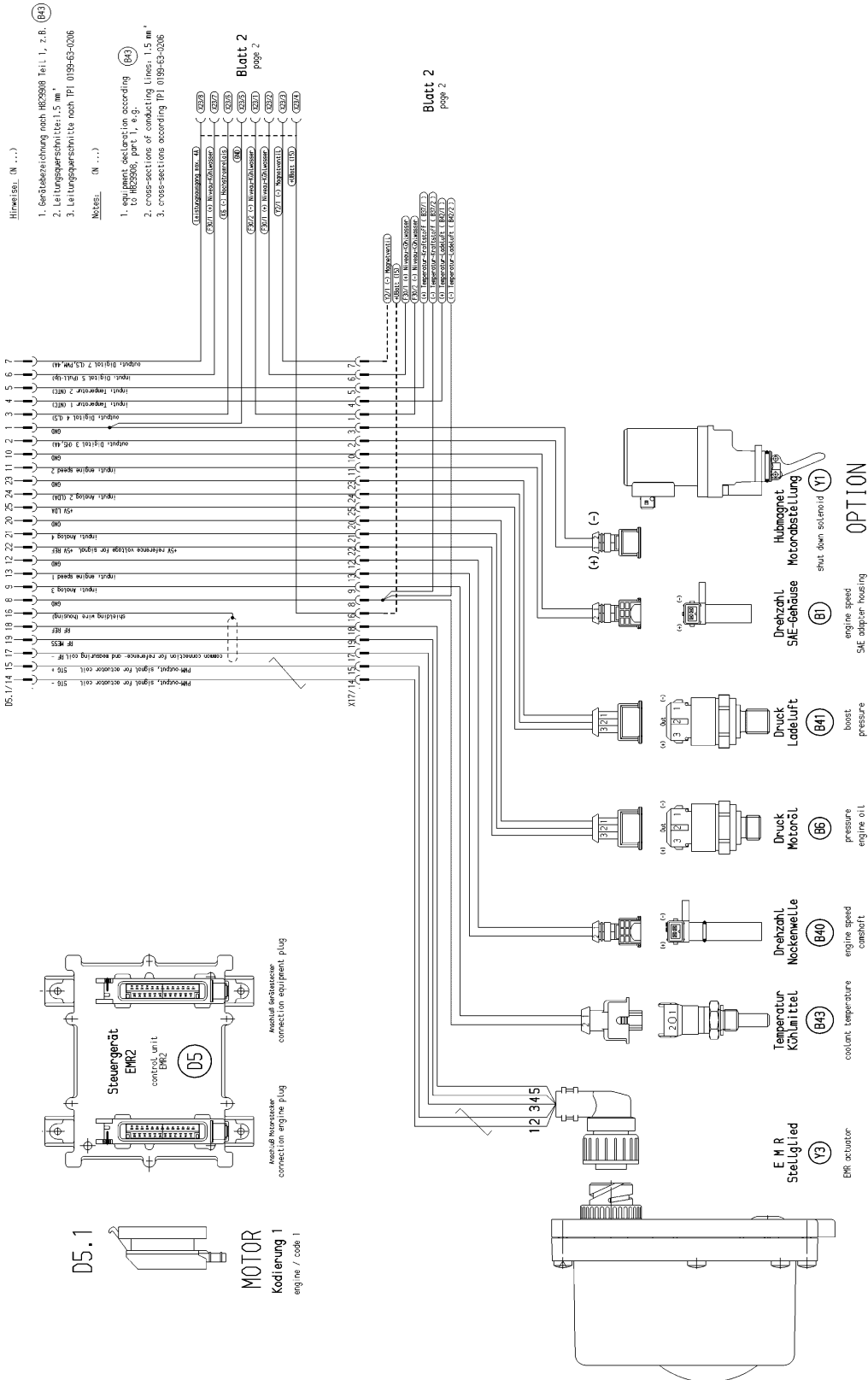

Figure 3-53. Deutz EMR 2 Engine Side Connection Diagram - Sheet 1 of 2

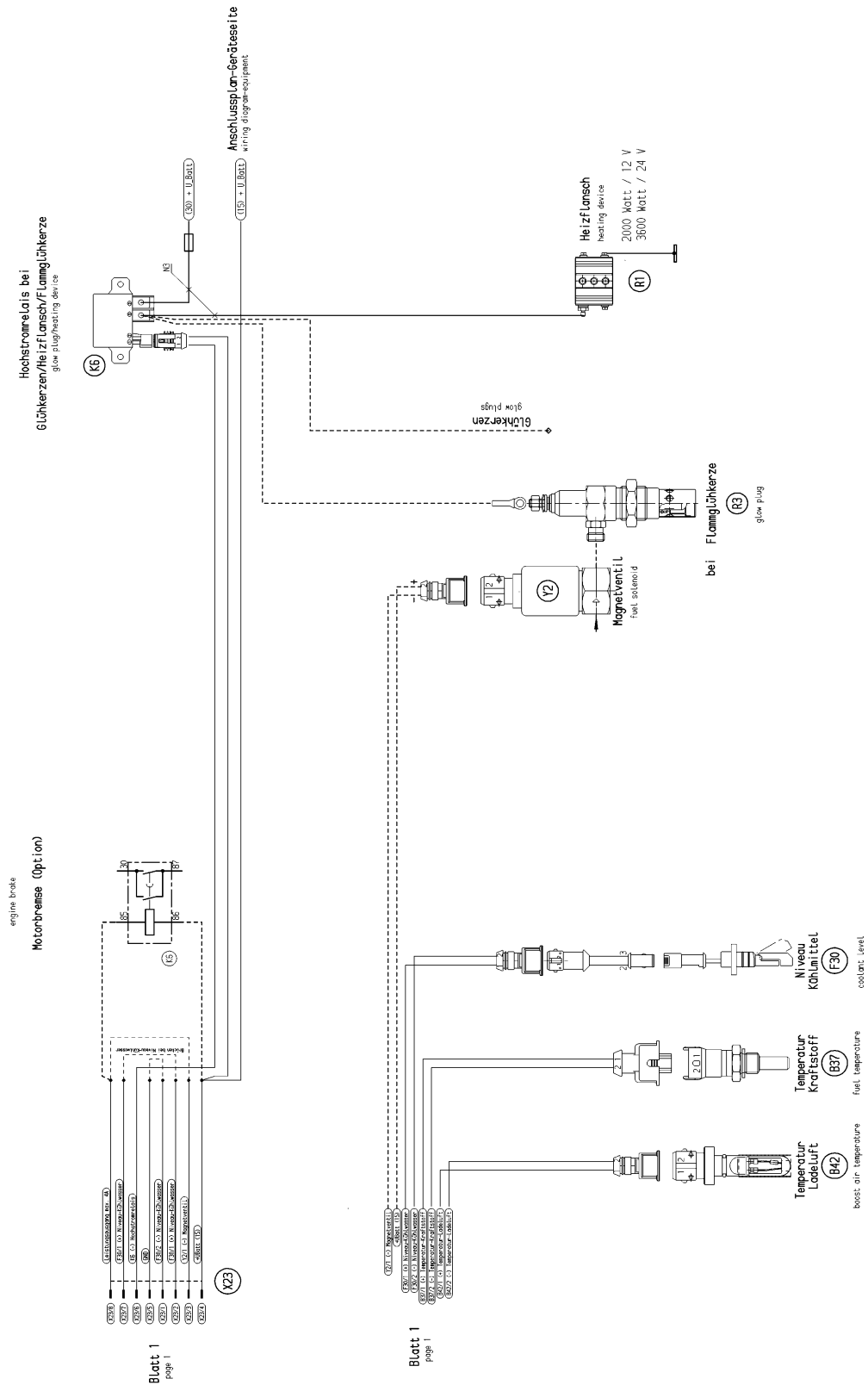
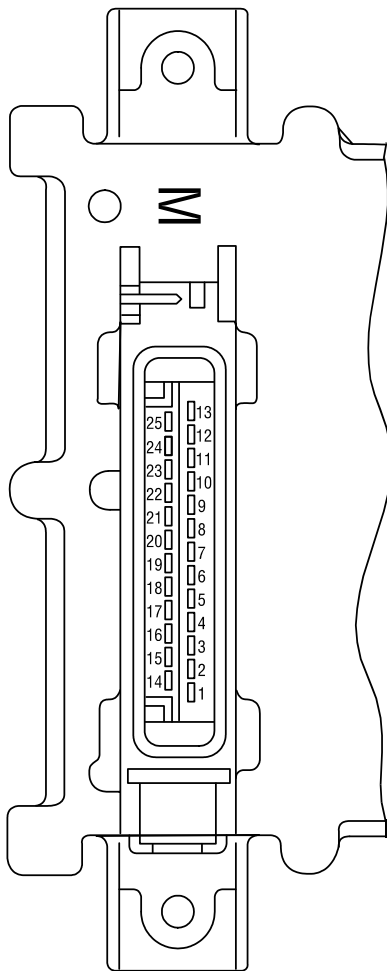

Figure 3-54. Deutz EMR 2 Engine Side Connection Diagram - Sheet 2 of 2

SECTION 3 - CHASSIS, PLATFORM & SCISSOR ARMS



Pin No.	Designation	Description
1	Reserve	Reserve
2	Output: digital 3	Digital output for solenoid ¹⁾
3	Output: digital 4	For heating flange (optional)/ glow plug (optional)
4	Input (optional) Temp 1	Fuel temperature ²⁾
5	Input (optional) Temp 2	Charge air temperature
6	Input (optional) DigIn 5	Coolant level / oil level
7	Output: PWM2/digital 6	
8	GND	Reference potential for analog signal at pin 9
9	Input: analog 7	Analog input for Coolant temperature sensor (NTC)
10	GND	Reference potential for analog signal at pin 11
11	Multi-function input: speed 2/DigIn 2	Digital input second engine speed (crankshaft) (optional) and speed signal (optional)
12	GND	Reference potential for analog signal at pin 13
13	Input: speed 1	Digital input first engine speed (camshaft)
14	STG -	PWM output, signal for actuator coil
15	STG +	PWM output, signal for actuator coil
16	Screen	Screening regulating rod travel sensor (for lines 17, 18, 19)
17	RF -	General connection for reference and measuring coil
18	RF REF	Analog input, reference signal of the reference coil
19	RF MESS	Analog input, measuring signal of the measuring coil
20	GND	Reference potential for signal at pin 21
21	Input: analog 4/digital 9	Analog input 4 (sensor signal oil pressure sensor) or digital input 9
22	+5 V REF	+5 V Reference voltage for signal at pin 21 (max. 15 mA)
23	GND	Reference potential for signal at pin 24
24	Input: analog 2/digital 7	Analog input 2 (sensor signal charge air) or digital input 7
25	+5 V LDA	+5 V Reference potential for signal at pin 24 (max. 15 mA)

1) For continuous power: < 4 A

2) Corresponds to special function "fuel temperature compensation at the EMR (0211 2571)

Figure 3-55. EMR 2 Engine Plug Pin Identification

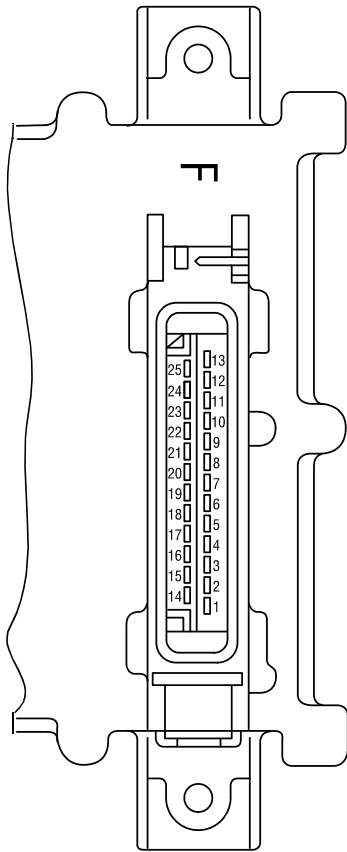

Pin-No.	Designation	Description
1	U Batt -	Negative pole at battery (clamp 31)
2	GND	Reference potential for signal
3	Output: digital 2	PWM or digital output, various functions
4	Input / output: DigInOut	Fault lamp and diagnostic button
5	Output: PWM 1/Dig 1	PWM or digital output, various functions
6	Multi-function input: DigIn 3	Genset applications/gear shift/motor brake
7	Input: digital 10/velocity	Speed signal (tacho input)
8	NC	Not occupied
9	NC	Not occupied
10	L-line	Serial ISO 9141 interface
11	K-line	Serial ISO 9141 interface
12	CAN high	Interface for CAN-Bus
13	CAN low	Interface for CAN-Bus
14	U Batt +	Positive pole for battery (clamp 15)
15	Output: digital 5	Digital output, various functions
16	Output: digital 7/Frequency	Frequency, PWM or digital output, various functions
17	Ground	Reference potential for signal at pins 18, 19 and 21
18	Input: digital 1 / PWM 1	PWM 1 or digital input 1, various functions
19	Multi-function input: DigIn 4	Performance curve switching/genset applications
20	Multi-function input: digital 8 / analog 3	Hand hand throttle/genset applications, Digital (8) or analog input (3)
21	Input: digital 2 / PWM 2	PWM 2 or digital input 2, various functions
22	Screen	Screening (e.g. for lines hand throttle or PWG)
23	GND	Reference potential for signal at pin 24
24	Input: analog 1 / digital 6	Analog input 1 (pedal value sensor, PWG) or digital input 6
25	+5 V REF	+5 V Reference voltage for signal at pin 24

Figure 3-56. EMR 2 Vehicle Plug Pin Identification

SECTION 3 - CHASSIS, PLATFORM & SCISSOR ARMS

Fault group	Fault no. (in SERDIA)	Fault locality/ Fault description	SPN	FMI	Cause	Remarks	Help
Zero error display	-	No faults	524287	31	No active faults present		
Revolutions / speed acquisition	01	Speed sensor 1	190	8	Sensor failure. Distance from gear too far. Additional fault impulses. Cable joint interrupted.	Governor in emergency operation (if sensor 2 available). Emergency switch-off (if sensor 2 not available or failed). Governor in emergency operation (with sensor 1) Emergency switch-off (if sensor 1 not available or failed).	Check distance. Check cable connection. Check sensor and replace if required.
	03	Speed sensor	84	8	Tacho failed. Additional fault impulses. Cable connection interrupted.	Governor in emergency operation.	Check cable connection and Tacho. Replace if required.
	04	Excess speed switch-off	190	0	Speed was/is in excess of limit.e. Check PID setting. Check rods. Check actuator and replace if required. Check cable to actuator (impulse on incorrect speed). Check No. of teeth. For vehicles check for possible thrust mode.	Engine stop.	Check parameter (21). Check speed settings.
Sensors	07	Charge air pressure	102	2			
	08	Oil pressure	100	2			
	09	Coolant temperature	110	2	Fault at corresponding sensor entry (e.g. short circuit or cable break).	With failure of the sensor, the associated monitoring function is de-activated.	Check sensor cable. Check sensor and replace if required. Check fault limits for sensor.
	10	Charge air temperature	105	2			
	11	Fuel temperature	174	2			

NOTE: SID is equal to 512. To get SPN #, add 512 + number. For example, SID 254 would be 512+254 or an SPN of 766.

Figure 3-57. EMR2 Fault Codes - Sheet 1 of 5

Fault group	Fault no. (in SERDIA)	Fault locality/ Fault description	SPN	FMI	Cause	Remarks	Help
Functional fault warning	30	Oil pressure warning	100	1	Oil pressure below speed-dependent warning line characteristic	Fault message (disappears when oil pressure is again above recovery limit). After a delay time - fill limitation.	Check engine (oil level, oil pump). Check oil pressure sensor and cable. Check oil pressure warning line characteristic.
	31	Coolant temperature warning	110	0	Coolant temperature has exceeded warning level.	Fault message (disappears when coolant temperature again drops below recovery level). After a delay time - fill limitation.	Check coolant. Check coolant temperature sensor and cable.
	32	Charge air temperature warning	105	0	Charge air temperature has exceeded warning level.	Fault message (disappears when charge air temperature gain drops below recovery level). After a delay time - fill limitation.	Check charge air. Check charge air-temperature sensor and cable.
	34	Coolant level warning	111	1	Switch input "Low coolant level" is active.	Fault message.	Check coolant level. Check coolant level sensor and cable.
	35	Speed warning (with thrust mode operation).	SID 190	14	revolutions was/is above (top) revolution speed limit. "Thrust mode" function is active.		Check parameters. Check speed settings.
	36	Fuel temperature warning	174	0	Fuel-temperature has exceeded warning level.	Fault message (disappears when fuel temperature again drops below recovery level).	Check fuel. Check fuel temperature sensor and cable.

NOTE: SID is equal to 512. To get SPN #, add 512 + number. For example, SID 254 would be 512+254 or an SPN of 766.

Figure 3-58. EMR2 Fault Codes - Sheet 2 of 5

SECTION 3 - CHASSIS, PLATFORM & SCISSOR ARMS

Fault group	Fault no. (in SERDIA)	Fault locality/ Fault description	SPN	FMI	Cause	Remarks	Help
Functional fault, switch-off	42	Charge air temperature switch-off	105	0	Charge air temperature has exceeded switch-off limit.	Emergency stop	Check charge air. Check charge air-temperature sensor and cable. Check switch-off limit.
	44	Coolant level switch-off	111	1	Switch input "Low coolant level" is active.	Emergency stop. Start lock.	Check coolant level. Check coolant level sensor and cable.
Actuator	50	Feedback	SID 24	12	Actuator not connected. Fault in actuator confirmation.	Emergency switch-off. Actuator cannot be operated.	Check actuator, replace if required. Check cable, check fault limits for "Confirmation".
	52	Reference feedback	SID 24	13			Check actuator, replace if required. Check cable, check fault limits for "Rifeness confirmation".
	53	Control travel difference	SID 23	7	Injection pump/actuator jammed or not connected. Difference between nominal/actual control travel is > 10 % of the overall control path.	Fault message (disappears when difference is < 10 %).	Check actuator/actuator rods / injection pump, replace if required. Check actuator cable.
	59	Auto calibration BOSCH-EDC pumps faulty operation	SID 23	13	No automatic actuator equalization possible. Incorrect input of the actuator reference values.	Engine stop / start lock. Governor cannot be taken into use. EDC actuator calibration required.	Check actuator and replaced if required. Check feedback cable.
							Check fault limits and reference values of the feedback. Program the fault limits for feedback, save the fault limits for feedback, save values. Switch ignition off and on again. Check again. If faulty, inform DEUTZ-Service and carry out automatic equalization again. Set fault limits again.

NOTE: SID is equal to 512. To get SPN #, add 512 + number. For example, SID 254 would be 512+254 or an SPN of 766.

Figure 3-59. EMR2 Fault Codes - Sheet 3 of 5

SECTION 3 - CHASSIS, PLATFORM & SCISSOR ARMS

Fault group	Fault no. (in SERDIA)	Fault locality/ Fault description	SPN	FMI	Cause	Remarks	Help
Hardware inputs/outputs	60	Digital output 3 (Switch-off solenoid, pin M 2)	SID 51	2	Fault (short circuit / cable break) at digital output.	Driver level is switched off.	Check cable of digital output (cable break or short circuit).
	62	Digital output 6, pin M 7	SID 60	2		Fault message.	
	63	Excess voltage switch-off solenoid	SID 51	6			
	67	Error Hand Setp1	91	11			
	68	Error CAN Setp1	898	2			
	Communication	70	CAN-Bus controller	SID 231	12	CAN-controller for CAN-bus is faulty. Fault removal despite re-initialising continuously not possible	Application-dependent.
71		CAN interface SAE J 1939	SID 231	9	Overflow in input buffer or a transmission cannot be placed on the bus.		Check CAN connection, cable connection. Check sensor and replace if required.
74		Cable break, short circuit or bus-error	SID 231	14			Switch ignition off and on again. Check again. If faulty inform DEUTZ Service
Memory	76	Parameter programming (write EEPROM)	SID 253	12	Fault in parameter programming in the governor fixed value memory.		
	77	Cyclic program test	SID 240	12	Constant monitoring of program memory shows error (so-called "Flash-test").	Emergency switch-off, engine cannot be started.	
	78	Cyclic RAM test	SID 254	2	Constant monitoring of working memory shows error.		Note values of parameters (3895 and 3896). Switch ignition off and on again. Check again. If faulty inform DEUTZ Service.

NOTE: SID is equal to 512. To get SPN #, add 512 + number. For example, SID 254 would be 512+254 or an SPN of 766.

Figure 3-60. EMR2 Fault Codes - Sheet 4 of 5

SECTION 3 - CHASSIS, PLATFORM & SCISSOR ARMS

Fault group	Fault no. (in SERDIA)	Fault locality/ Fault description	SPN	FMI	Cause	Remarks	Help
Control unit hardware	80	Power supply (Actuator)	SID 254	2	Power supply for actuator not in the permissible range.	Fault message (disappears when power again in the normal range).	Switch ignition off and on again. Check again. If faulty inform DEUTZ Service.
	83	Reference voltage 1	SID 254	2	Reference voltage for actuator not in the permissible range.	Fault message (disappears when power again in the normal range). Auxiliary value 5 V	Check voltage supply. Switch ignition off and on again. Check again. If faulty inform DEUTZ Service.
	84	Reference voltage 2	SID 254	2			
	85	Reference voltage 4	SID 254	2			
	86	Internal temperature	171	12	Internal temperature for control unit not in permissible range.	Fault message (disappears when power again in the normal range).	Switch ignition off and on again. Check again. If faulty inform DEUTZ Service.
87	Atmospheric pressure	108	12	Atmospheric pressure not in permissible range.	Fault message (disappears when power again in normal range). Atmospheric pressure monitoring function de-activated.	Switch ignition off and on again. Check again. If faulty inform DEUTZ Service.	
Program logic	90	Parameter fault (EEPROM retrieval or checksum faulty).	SID 253	2	No data found or checksum of data is faulty (note: fault only occurs during setting of parameter / saving or reset).	Engine cannot be started.	Check data for correct settings. Save parameters. Switch ignition off and on again. Check again. If faulty inform DEUTZ Service.
	93	Stack overflow	SID 240	2	Internal calculation fault (so-called "Stack overflow" fault).	Emergency switch-off. Engine cannot be started.	Note parameters (3897 and 3898). Switch ignition off and on again. Check again. If faulty inform DEUTZ Service.
	94	Internal fault	SID 254	2			

NOTE: SID is equal to 512. To get SPN #, add 512 + number. For example, SID 254 would be 512+254 or an SPN of 766.

Figure 3-61. EMR2 Fault Codes - Sheet 5 of 5

Generator (if equipped)

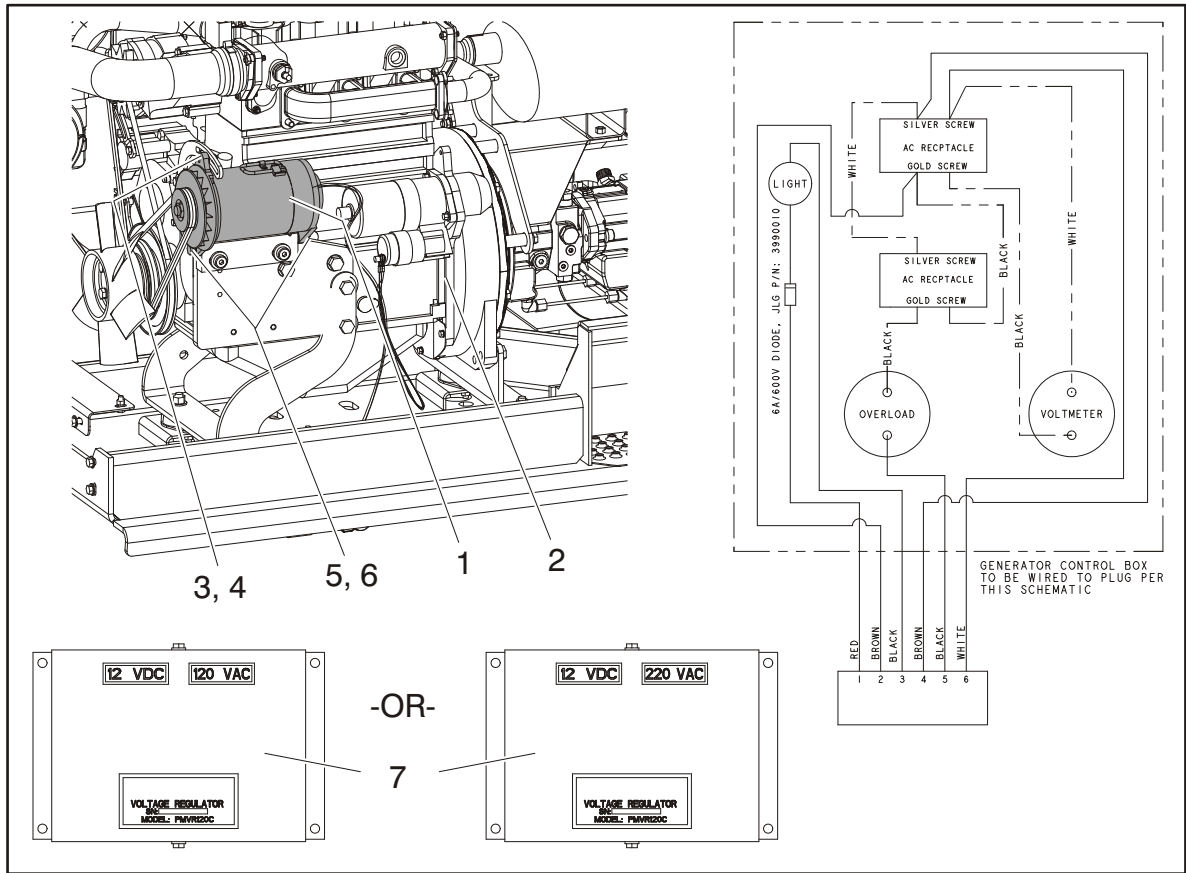

- | | | |
|-----------------------------|------------------------------|----------------------|
| 1. Generator (120V or 220V) | 4. Washer | 7. Voltage Regulator |
| 2. Deutz Engine | 5. Bolt, 7/16"-14NC x 2 1/4" | |
| 3. Bolt, 5/16"-18NC x 1" | 6. Washer | |

Figure 3-62. Generator (Deutz Engine)

⚠ CAUTION

ALLOW ENGINE AND COMPONENTS TO COOL DOWN BEFORE SERVICING.

REMOVAL:

1. Disable machine operation. Disconnect and label electrical wires attached to generator (1).
2. Remove the generator from the engine (2) by removing the three bolts (3, 5) and washers (4, 5).
3. Replace belt if damaged.

INSTALLATION:

1. Follow Removal Steps in reverse. Ensure belt is tight before securing generator with the bolts.

NOTE: Apply Loctite® #242 to the bolts (3, 5).

Table 3-13. Generator Specifications

Description	110 Bluemax	220 Powermax
Voltage	120V	220V
Continuous	3.5 KW	2.0 KW
Peak	4.5 KW	3.0 KW
Amps Peak	37 Amps	13 Amps

Exhaust System

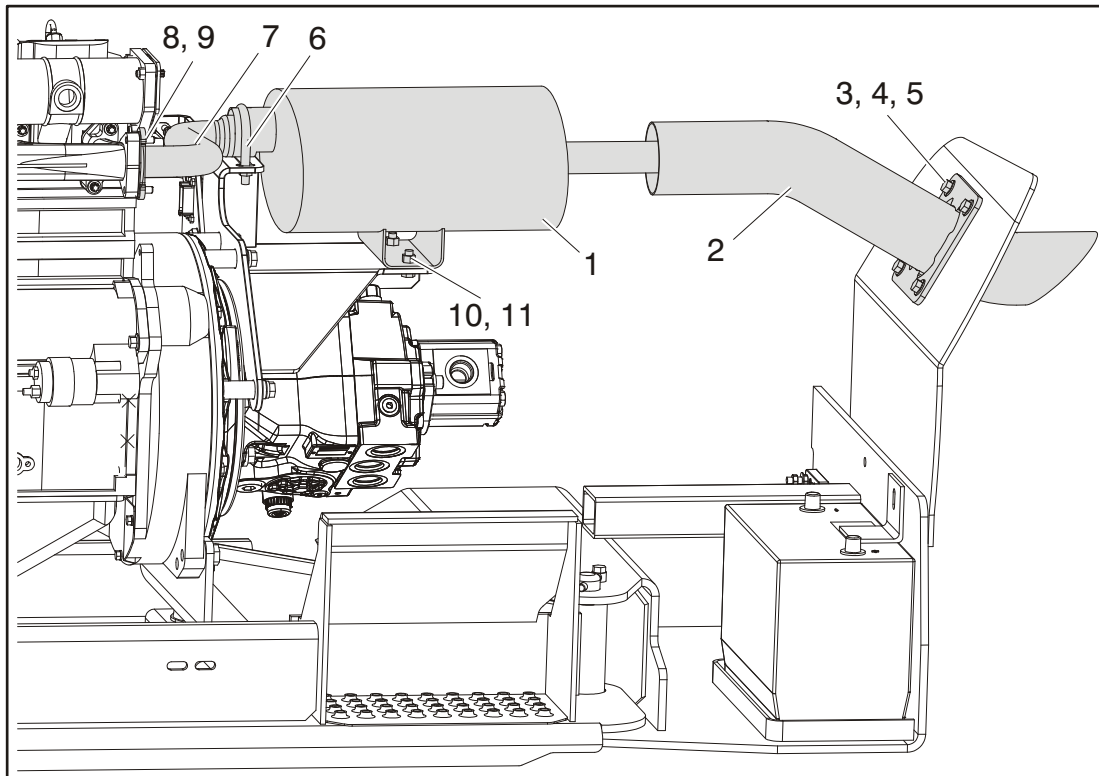

- | | | |
|-------------------------|-----------------|--------------------------|
| 1. Muffer | 5. Nut | 9. Washer |
| 2. Exhaust Tail Pipe | 6. Clamp | 10. Bolt, 3/8"NC-16 x 1" |
| 3. Bolt, 3/8"NC-16 x 1" | 7. Exhaust Pipe | 11. Washer |
| 4. Washer | 8. Nut | |

Figure 3-63. Exhaust System (Deutz Engine)

⚠ CAUTION

ALLOW ENGINE AND COMPONENTS TO COOL DOWN BEFORE SERVICING.

REMOVAL:

1. Disable machine operation.
2. Remove the tail pipe (2) by removing the bolts (3), washers (4) and nuts (5).
3. Loosen the clamp (6).
4. Remove the bolts (10) and washers (11) connecting the muffer (1) to the mounting bracket. Remove muffer.
5. Remove exhaust pipe (7) by removing the nuts (8) and washers (9).

INSTALLATION:

1. Follow Removal Steps in reverse.

NOTE: Apply Loctite® #242 to bolt (10).

Air Cleaner System

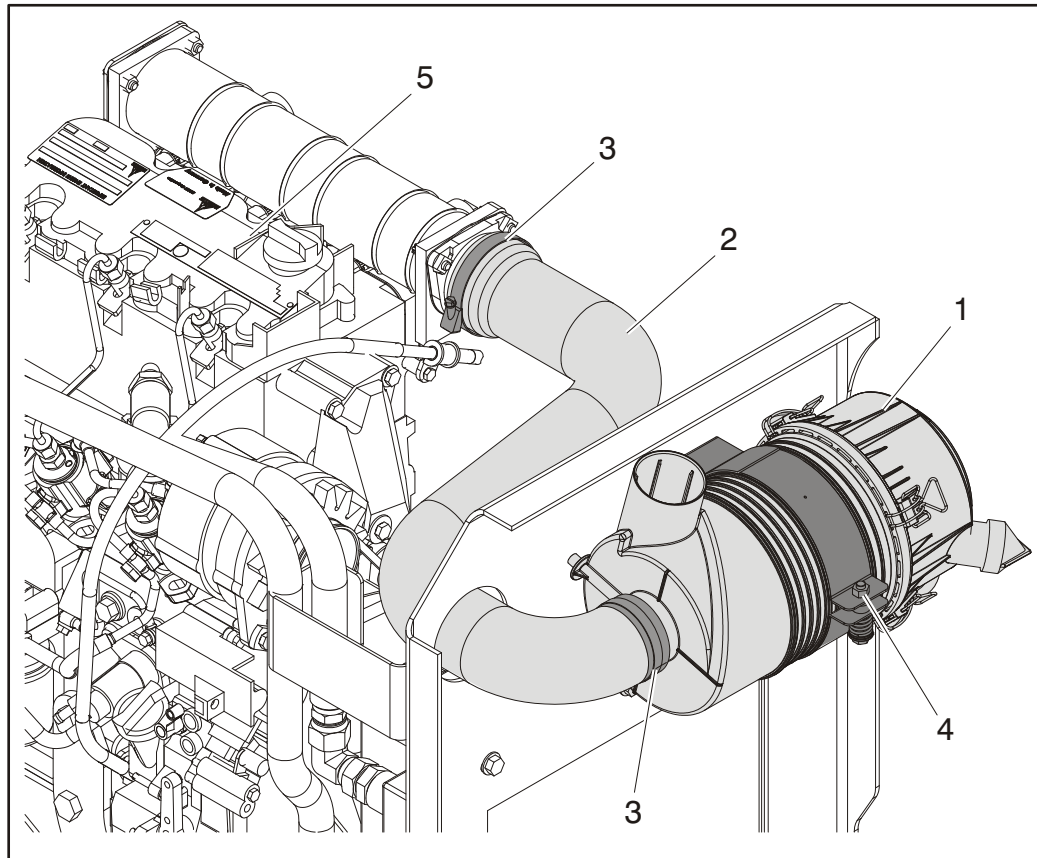

1. Air Cleaner
2. Air Intake Hose
3. Clamp
4. Mounting Bracket
5. Engine

Figure 3-64. Air Cleaner System (Deutz Engine)

⚠ CAUTION

ALLOW ENGINE AND COMPONENTS TO COOL DOWN BEFORE SERVICING.

REMOVAL:

1. Disable machine operation.
2. Loosen the two clamps (3) attaching the air intake hose (2) to the engine (5) and air cleaner (1).
3. Unscrew the bolt on the clamp (3) and remove the air cleaner.
4. Remove the air intake hose.

NOTE: *The filter element can be removed from the air cleaner by releasing the latches on the end of the air cleaner. Replace filter element as needed.*

INSTALLATION:

1. Follow Removal Steps in reverse.

Relays

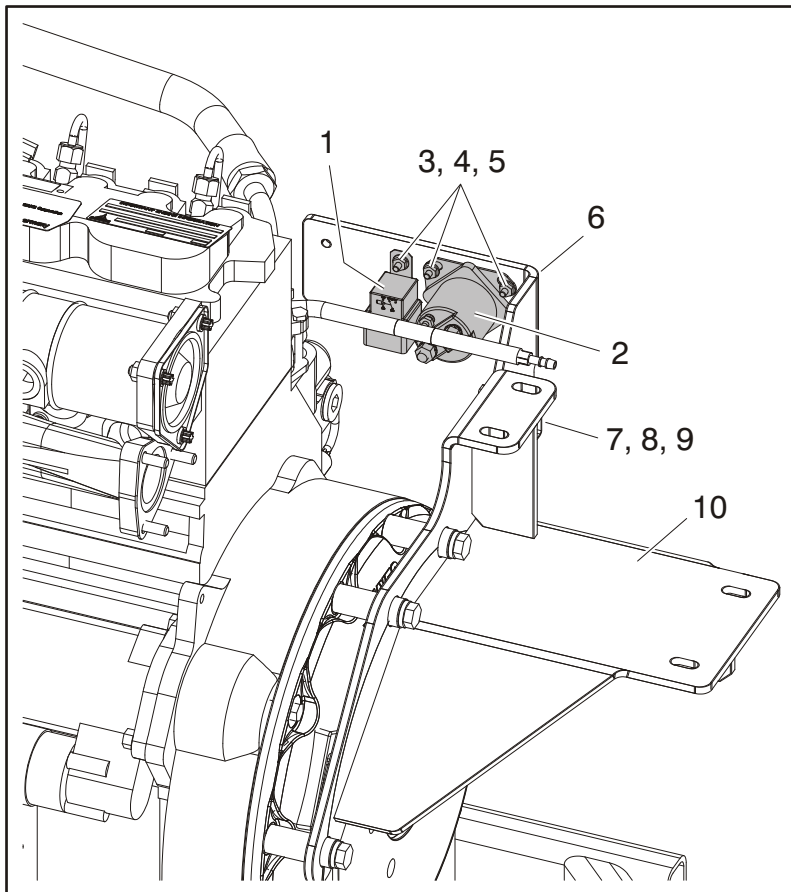

1. Weather Proof Relay
2. Solenoid Relay
3. Bolt, NO10-24 x 0.75"
4. Locknut
5. Washer
6. Relay Mounting Bracket
7. Glow Plug Harness
8. Bolt, NO8-32 x 0.625"
9. Locknut
10. Muffler Mounting Bracket

Figure 3-65. Relays (Deutz Engine)

REMOVAL:

1. Disable machine operation.
2. Disconnect and label the wires and harnesses attached to the weather proof relay (1), solenoid relay (2) and glow plug harness (7).
3. Remove the relays from the mounting bracket (6) by removing the bolts (3), locknuts (4) and washers (5).
4. The relay mounting bracket can be removed from the muffler mounting bracket (10) by removing the two bolts, nuts and washers (not shown).

INSTALLATION:

1. Follow Removal Steps in reverse.

Pumps

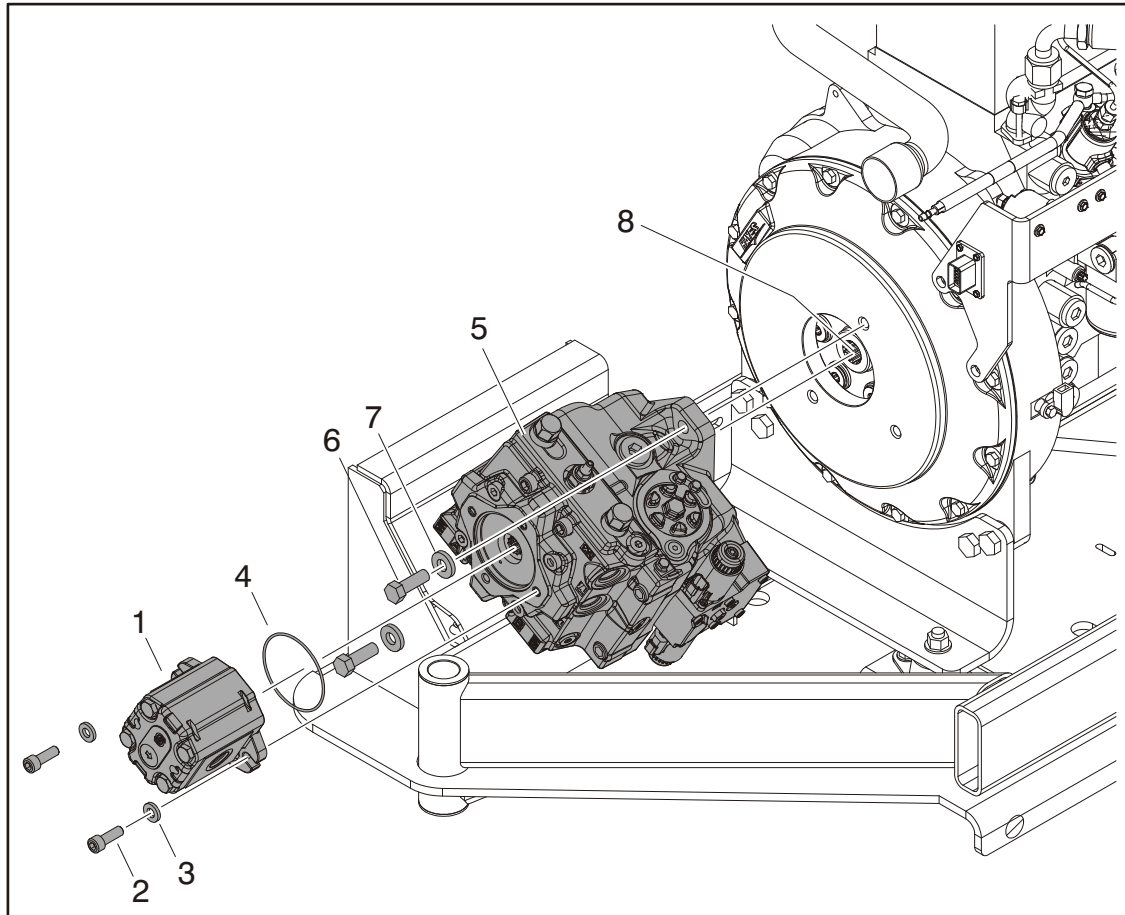

- | | | |
|-------------------------|-----------------------------|------------------|
| 1. Gear Pump | 4. O-ring | 7. Washer, |
| 2. Bolt, 3/8"-16NC x 1" | 5. Axial HI 45 Pump | 8. Pump Coupling |
| 3. Washer | 6. Bolt, 1/2"-13NC x 1 1/2" | |

Figure 3-66. Pump Assemblies (Deutz Engine)

⚠ CAUTION

ALLOW ENGINE AND COMPONENTS TO COOL DOWN BEFORE SERVICING.

REMOVAL:

1. Disable machine operation. Disconnect, cap and label all hydraulic hoses connected to pumps (1, 5). Disconnect and label all wiring connected to pumps.
2. Remove the two bolts (2) and washers (3) attaching the gear pump (1) to the axial pump (5). Carefully remove the gear pump.
3. Remove and discard the o-ring (4).

4. Remove the two bolts (6) and washers (7) attaching the axial pump to the flange of the motor. Carefully remove the axial pump.

INSTALLATION:

1. Follow Removal Steps in reverse.

NOTE: Apply grease to internal splines of pump coupling (1) and external splines of axial pump (5) shaft prior to installing pump.

Install a new o-ring (4) during installation.

Apply Loctite® #242 to bolts (2, 6).

Torque mounting bolts (6) to 50 ft. lbs. (70 Nm)

NOTE: Refer to Section 4.9, Gear Pump and Section 4.10, Axial HI 45 Pump for more information on pumps.

Pump Coupling

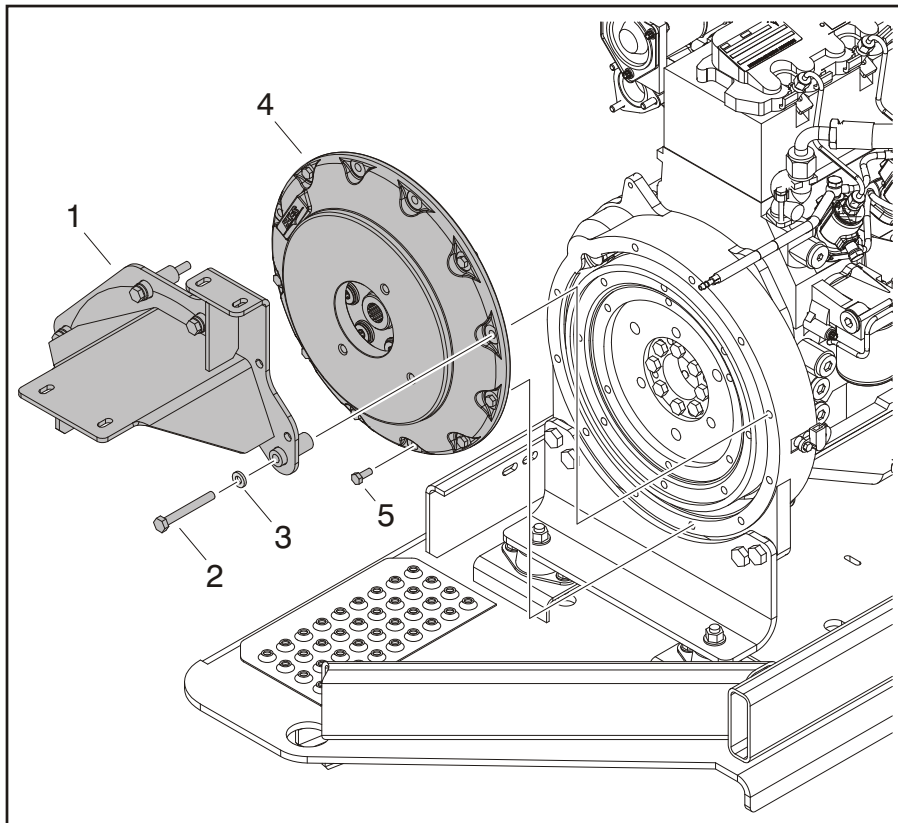

1. Muffer Mounting Bracket
2. Bolt, M10 x 85mm
3. Washer
4. Pump Coupling
5. Bolt, Coupling

Figure 3-67. Pump Coupling (Deutz Engine)

⚠ CAUTION

ALLOW ENGINE AND COMPONENTS TO COOL DOWN BEFORE SERVICING.

REMOVAL:

1. Disable machine operation.
2. Remove exhaust system and pumps (refer to Figure 3-63. and Figure 3-66.).
3. Remove the four bolts (2) and washers to remove the muffer mounting bracket (1) from the pump coupling (4).
4. Remove the eight coupling bolts (5) to remove the pump coupling from the engine

INSTALLATION:

1. Follow Removal Steps in reverse.

NOTE: Apply Loctite® #242 to bolts (2).
Torque coupling bolts to 50 lb-ft (68 Nm).

Engine Removal

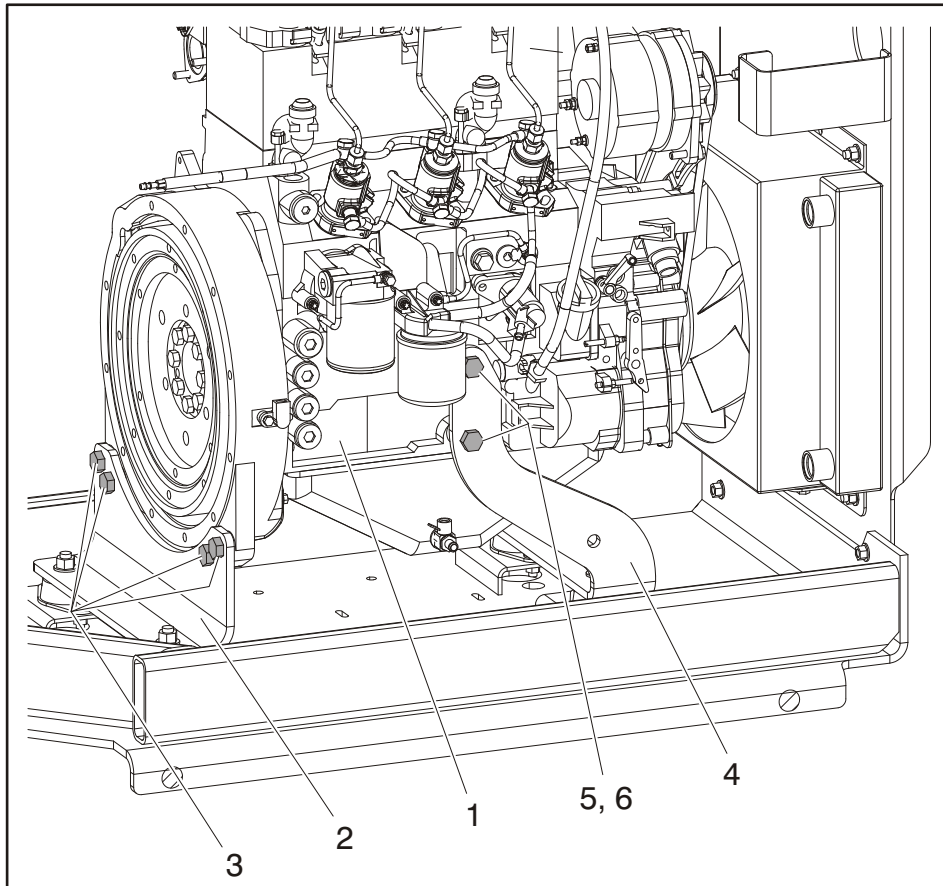

1. Deutz Engine
2. Rear Engine Mount
3. Bolt, M14 x 30mm
4. Front Engine Mount
5. Bolt, M14 x 55mm
6. Spacer Tube

Figure 3-68. Engine Removal (Deutz Engine)

⚠ CAUTION

ALLOW ENGINE AND COMPONENTS TO COOL DOWN BEFORE SERVICING.

REMOVAL:

1. Disable machine operation.
2. Remove exhaust system, air cleaner system and hydraulic pumps (refer to Figure 3-63., Figure 3-64. and Figure 3-66.).
3. Disconnect, cap and label all hoses connected to engine (1). Disconnect and label all electrical wiring connected to engine.
4. Support engine with lifting device capable of lifting 500 lbs (227 kg) (refer to engine manual for proper lifting information).
5. Remove the bolts (3) securing the motor to the rear engine mount (2).

6. Remove the bolts (5) and spacer tubes (6) securing the engine to the front engine mount (4).
7. Slowly lift the engine up and out of the engine compartment.

NOTICE

BE CAREFUL NOT TO DAMAGE THE RADIATOR FAN ON THE RADIATOR HOUSING WHEN LIFTING THE ENGINE.

INSTALLATION:

1. Follow Removal Steps in reverse.

NOTE: Apply Loctite® #242 to bolts (3, 5).

Radiator

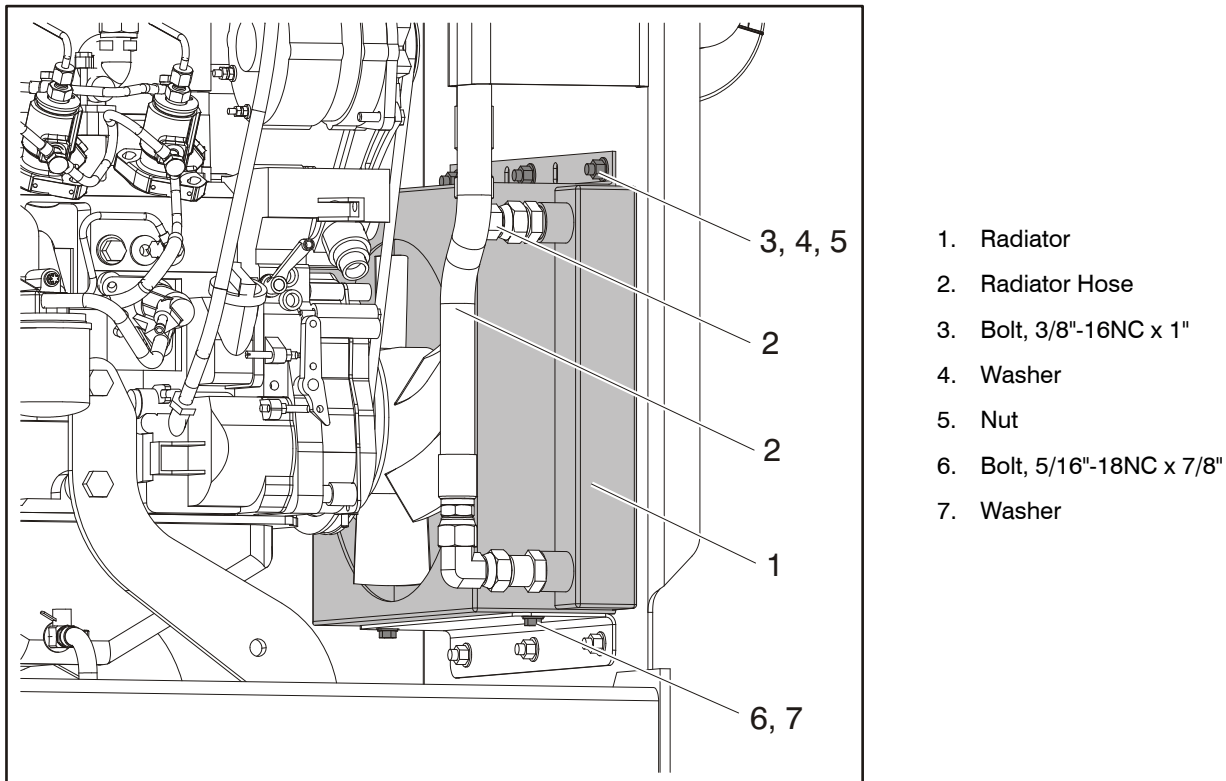

Figure 3-69. Radiator (Deutz Engine)

⚠ WARNING

ALLOW RADIATOR TO COOL DOWN BEFORE SERVICING.

INSTALLATION:

1. Follow Removal Steps in reverse.

REMOVAL:

1. Disable machine operation.
2. Disconnect, cap and label the radiator hoses (2) on the radiator (1).
3. Remove the engine (refer to Figure 3-68., Engine Removal (Deutz Engine)).
4. Remove the bolts (3, 6), washers (4, 7) and nuts (5) to remove the radiator from the engine compartment.

3.17 GM ENGINE

Maintenance of the Drive Belt

The serpentine drive belt utilizes a spring loaded tensioner which keeps the belt properly adjusted. The drive belt is an integral part of the cooling and charging systems and should be inspected frequently.

When inspecting the belts, check for:

- Cracks or breaks
- Chunking of the belt
- Splits
- Material hanging from the belt
- Glazing and hardening
- Damaged or improperly aligned pulleys
- Improperly performing tensioner

Check the belt tensioner by pressing down on the midway point of the longest stretch between pulleys. The belt should not depress beyond 1/2 inch (13mm). If the depression is more than allowable, adjust the tension.

NOTICE

THE ENGINE MANUFACTURER DOES NOT RECOMMEND THE USE OF "BELT DRESSING" OR "ANTI SLIPPING AGENTS" ON THE DRIVE BELT.

BELT ADJUSTMENT:

1. Remove existing belt and discard.
2. Install new belt (21mm x 1187mm).
3. Unload spring in belt tensioner.
4. Return alternator adjustment to original position and tighten bolt.
5. Release belt tensioner.
6. Check position of belt tensioner stop.
7. Readjust alternator position as necessary to allow correct position of belt tensioner stop.

Engine Electrical System Maintenance

The engine electrical system incorporates computers and microprocessors to control the engine ignition, fuel control, and emissions. Due to the sensitivity of the computers to good electrical connections, periodic inspection of the electrical wiring is necessary. When inspecting the electrical system use the following:

- Check and clean the battery terminal connections and ensure the connections are tight.
- Check the battery for any cracks or damage to the case.

- Check the Positive and Negative battery cables for any corrosion build up, rubbing or chafing, Check connection on the chassis to ensure they are tight.
- Check the entire engine wire harness for rubbing chafing, cuts or damaged connections. Repair if necessary.
- Check all wire harness connectors to ensure they are fully seated and locked.
- Check ignition coil and spark plug cables for hardening, cracking, chafing, separation, split boot covers and proper fit.
- Replace spark plugs at the proper intervals as prescribed in the engine manufacturer's manual.
- Check to make sure all electrical components are fitted securely.
- Check the ground and platform control stations to ensure all warning indicator lights are functioning.

Checking/Filling Engine Oil Level

CAUTION

AN OVERFILLED CRANKCASE (OIL LEVEL OVER THE SPECIFIED FULL MARK) CAN CAUSE AN OIL LEAK, A FLUCTUATION OR DROP IN THE OIL PRESSURE, AND ROCKER ARM "CLATTER" IN THE ENGINE.

NOTICE

CARE MUST BE TAKEN WHEN CHECKING THE ENGINE OIL LEVEL. OIL LEVEL MUST BE MAINTAINED BETWEEN THE "ADD" MARK AND "FULL" MARK ON THE DIPSTICK.

To ensure that you are not getting a false reading, make sure the following steps are taken before checking the oil level.

1. Stop the engine if in use.
2. Allow sufficient time (approximately 5 minutes) for the oil to drain back into the oil pan.
3. Remove the dipstick. Wipe with a clean cloth or paper towel and reinstall. Push the dipstick all the way into the dipstick tube.
4. Remove the dipstick and note the oil level.

- Oil level must be between the "FULL" and "ADD" marks.

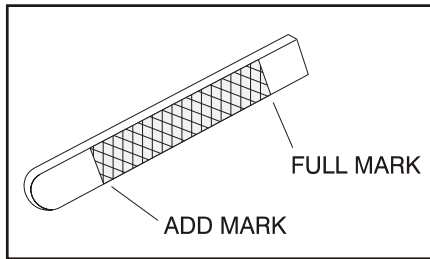

Figure 3-43. Engine Oil Dip Stick

- If the oil level is below the "ADD" mark, proceed to Step 7 and 8 and reinstall the dipstick into the dipstick tube.
- Remove the oil filter cap from the valve rocker arm cover.
- Add the required amount of oil to bring the level up to but not over "FULL" mark on the dipstick.
- Reinstall the oil fill cap to the valve rocker cover and wipe away any excess oil.

Changing The Engine Oil

NOTICE

WHEN CHANGING THE OIL, ALWAYS CHANGE THE OIL FILTER. CHANGE OIL WHEN THE ENGINE IS WARM FROM OPERATION AS THE OIL WILL FLOW FREELY AND CARRY AWAY MORE IMPURITIES.

To change the oil use the following steps:

- Start the engine and run until it reaches normal operating temperature.
- Stop the engine.
- Remove the drain plug and allow the oil to drain.
- Remove and discard the oil filter and its sealing ring.
- Coat the sealing ring on the filter with clean engine oil and wipe the sealing surface on the filter mounting surface to remove any dust, dirt and debris. Tighten the filter securely (follow the filter manufacturer's instructions). Do not over tighten.
- Check the sealing ring on drain plug for any damage. Replace if necessary. Wipe the plug with a clean rag and wipe the sealing surface on the pan and reinstall the pan plug. Do not over tighten.
- Fill the crankcase with oil.
- Start the engine and check for oil leaks.
- Stop the engine and check the oil level to ensure the oil level is at "FULL".
- Dispose of the oil and filter in a safe manner.

Engine Tray

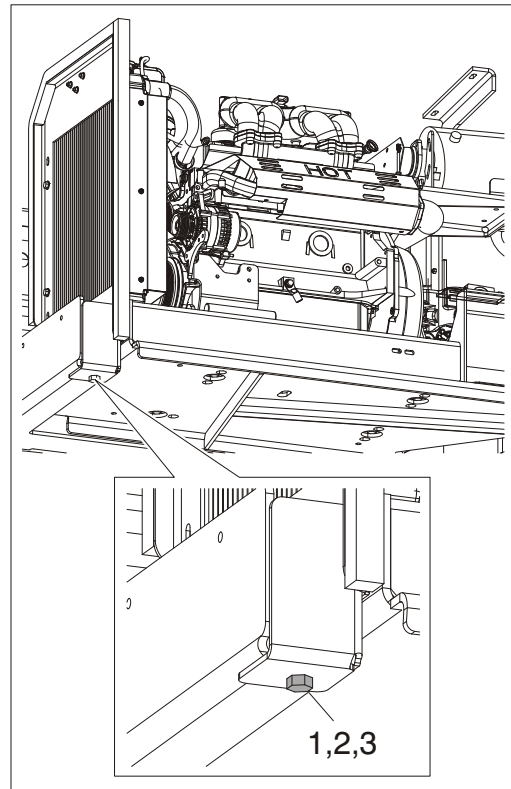

- Bolt, 5/8"-11NC x 2"
- Nut
- Washer

NOTE: When servicing the engine and components, remove the bolt (1), nut (2) and washer (3) to swing the engine tray out for better access (as shown below).

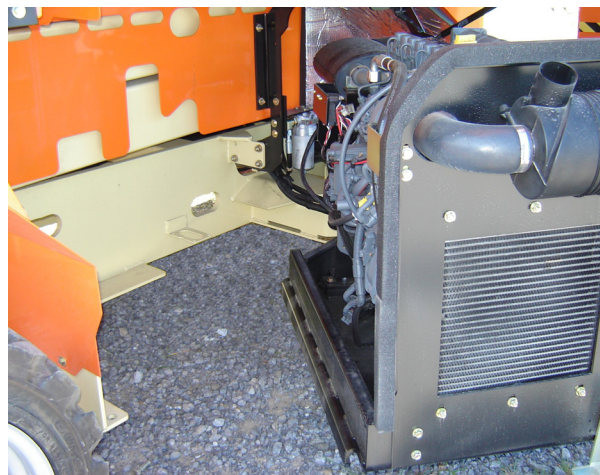
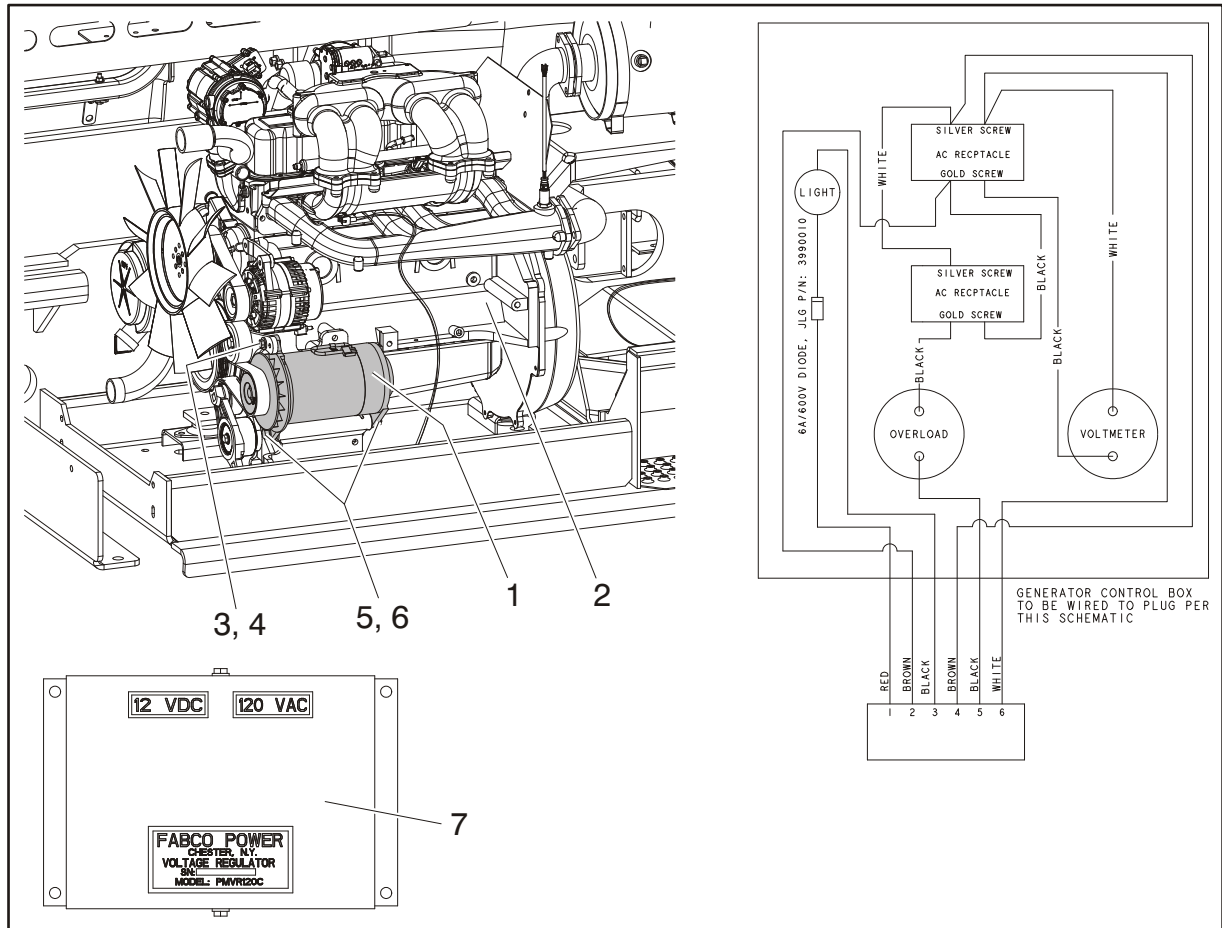

Figure 3-70. Engine Tray Swing

Generator



- | | | |
|------------------------------|------------------------------|----------------------|
| 1. Generator | 4. Washer | 7. Voltage Regulator |
| 2. GM Engine | 5. Bolt, 7/16"-14NC x 1 1/4" | |
| 3. Bolt, 5/16"-18NC x 1 1/4" | 6. Washer | |

Figure 3-71. Generator (GM Engine)

CAUTION

ALLOW ENGINE AND COMPONENTS TO COOL DOWN BEFORE SERVICING.

REMOVAL:

1. Disable machine operation. Disconnect and label electrical wires attached to generator (1).
2. Remove the generator from the engine (2) by removing the three bolts (3, 5) and washers (4, 5).
3. Replace belt if worn or damaged.

INSTALLATION:

1. Follow Removal Steps in reverse. Ensure belt is tight before securing generator with the bolts.

NOTE: Apply Loctite® #242 to the bolts (3, 5).

Table 3-14. Generator Specifications

Voltage	120V
Continuous	3.5 KW
Peak	4.5 KW
Amps Peak	37 Amps

Exhaust System

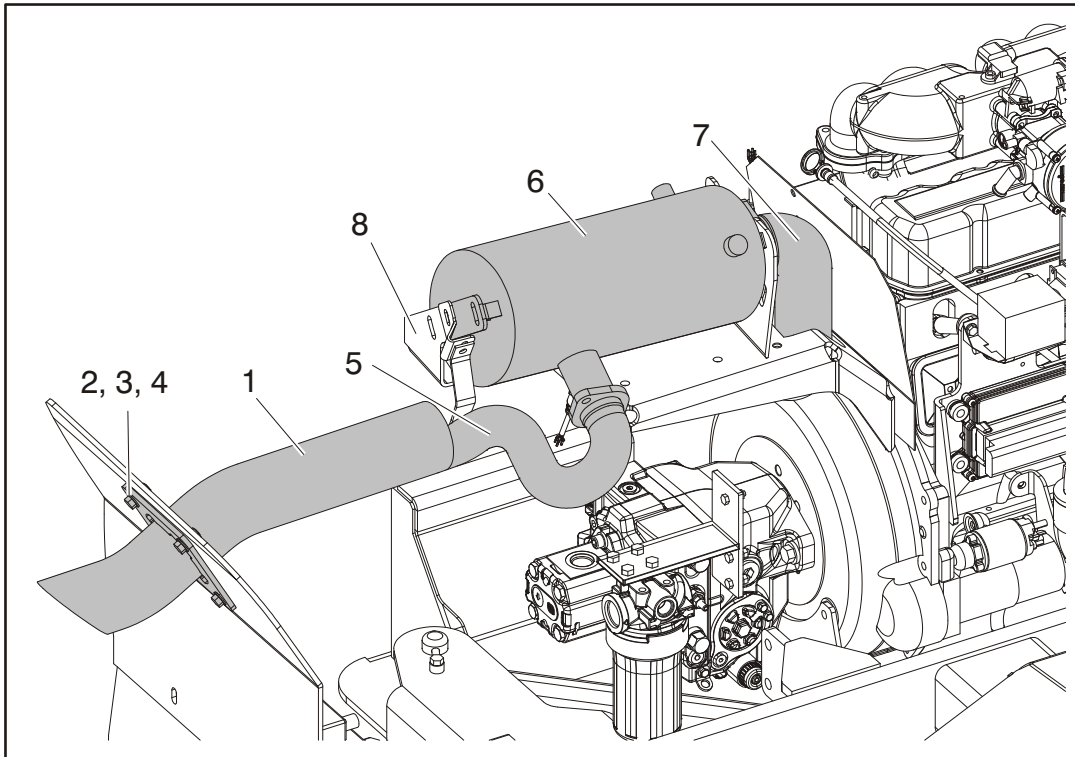

- | | | |
|-------------------------|-----------------|---------------------|
| 1. Tail Pipe | 4. Nut | 7. Exhaust Pipe |
| 2. Bolt, 3/8"-16NC x 1" | 5. Exhaust Pipe | 8. Mounting Bracket |
| 3. Washer | 6. Muffler | |

Figure 3-72. GM Exhaust System (GM Engine)

⚠ CAUTION

ALLOW ENGINE AND COMPONENTS TO COOL DOWN BEFORE SERVICING.

REMOVAL:

1. Disable machine operation.
2. Remove the exhaust pipe (5) from the muffler (6) and tail pipe (1) by removing the bolts.
3. Remove the tail pipe by removing the bolts (2), washers (3) and nuts (4).
4. Remove exhaust pipe (7) from the muffler and engine by removing the bolts.
5. Remove the bolts connecting the muffler to the mounting bracket (8). Remove muffler.

INSTALLATION:

1. Follow Removal Steps in reverse.

Air Cleaner System

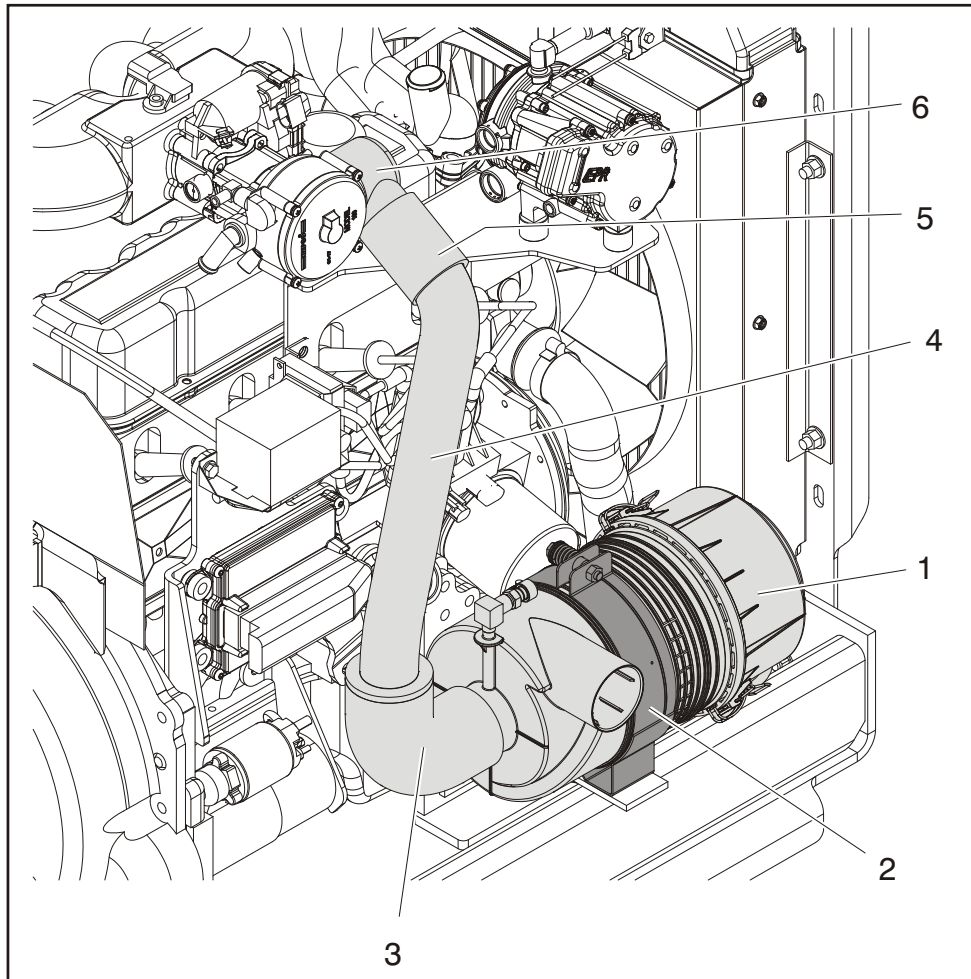

1. Air Cleaner
2. Mounting Bracket
3. Rubber Elbow
4. Air Intake Tube
5. Sleeve
6. Air Intake Tube

Figure 3-73. Air Cleaner System (GM Engine)

⚠ CAUTION

ALLOW ENGINE AND COMPONENTS TO COOL DOWN BEFORE SERVICING.

REMOVAL:

1. Disable machine operation.
2. Pull the rubber elbow (3) off of the air cleaner (1) and air intake tube (4).
3. Pull the air intake tube out of the sleeve (5). Pull the sleeve and air intake tube (6) out of the engine.
4. Loosen the bolt on the mounting bracket (2) to remove the air cleaner (1).

NOTE: The filter element can be removed from the air cleaner by releasing the latches on the end of the air cleaner. Replace filter element as needed.

INSTALLATION:

1. Follow Removal Steps in reverse.

Radiator

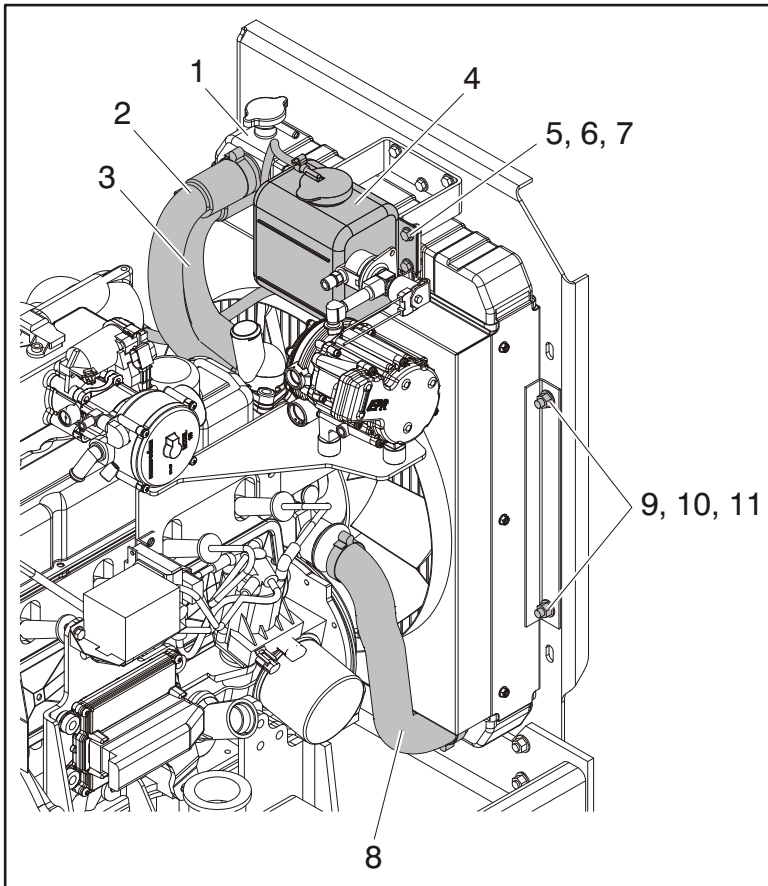

1. Radiator
2. Radiator Hose
3. Radiator Hose
4. Coolant Overflow Container
5. Bolt, 1/4"-20NC x 7/8"
6. Washer
7. Nut
8. Radiator Hose
9. Bolt, 3/8"-16NC x 1"
10. Washer
11. Nut

Figure 3-74. Radiator (GM Engine)

⚠ WARNING

ALLOW RADIATOR TO COOL DOWN BEFORE SERVICING.

REMOVAL:

1. Drain the anti-freeze fluid from the radiator (1) by opening the valve on the bottom corner of the radiator. Store fluid in a suitable container.
2. Loosen the clamps on the radiator hoses (2, 3, 5) and remove the hoses.
3. Disconnect and cap the hoses connected to the coolant overflow container (4).
4. Remove the bolts (5) washers (6) and nuts (7) to remove the coolant overflow container from the mounting bracket.
5. Remove the four bolts (9), washers (10) and nuts (11) to remove the radiator.

NOTE: The engine must be removed before the radiator can be removed.

INSTALLATION:

1. Follow Removal Steps in reverse.
2. Ensure drain valve on radiator (1) is closed. Refill radiator with 2.63 gal (10 ltr) of anti-freeze fluid.

Fuel Components

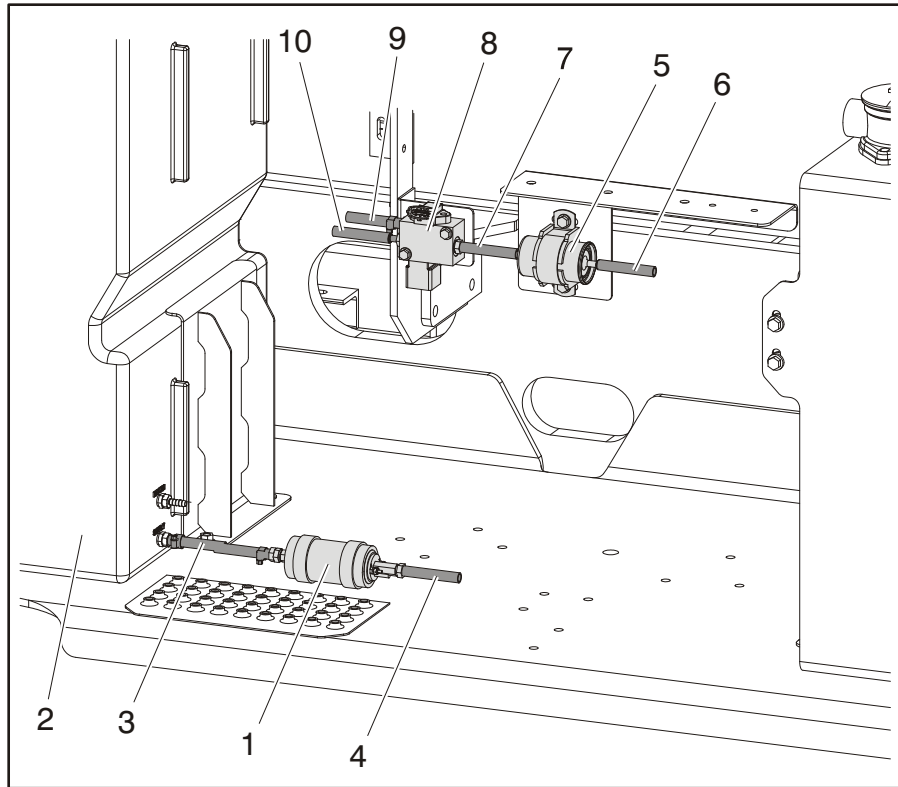

1. Fuel Pump
2. Fuel Tank
3. Fuel Line - Supply from Tank
4. Fuel Line - to Fuel Filter
5. Fuel Filter
6. Fuel Line - to Fuel Pump
7. Fuel Line
8. Fuel Regulator
9. Fuel Line - Return to Tank
10. Fuel Line - to Engine

Figure 3-75. Fuel Components (GM Engine)

⚠ CAUTION

ALLOW ENGINE AND COMPONENTS TO COOL DOWN BEFORE SERVICING.

REMOVAL:

1. Disable machine operation.
2. Disconnect, label and cap all fuel lines (3, 4, 6, 7, 9, 10).

NOTE: Fuel will still be in the fuel lines. Drain the lines and store fuel in a suitable container.

3. Remove the bolts, nuts and washers attaching the fuel pump (1), fuel filter (5) and fuel regulator (8) to the machine.

INSTALLATION:

1. Follow Removal Steps in reverse.
2. Uncap and connect the fuel line (3) to the supply valve of the fuel tank (2) and the fuel pump (1).
3. Uncap and connect the fuel line (4) to the fuel pump and fuel filter (5).
4. Uncap and connect the fuel line (7) to the fuel filter and fuel regulator (8).
5. Uncap and connect the fuel line (9) to the fuel regulator and the return valve on the fuel tank.
6. Uncap and connect the fuel line (10) to the fuel regulator and the fuel rail on the engine.

Pumps

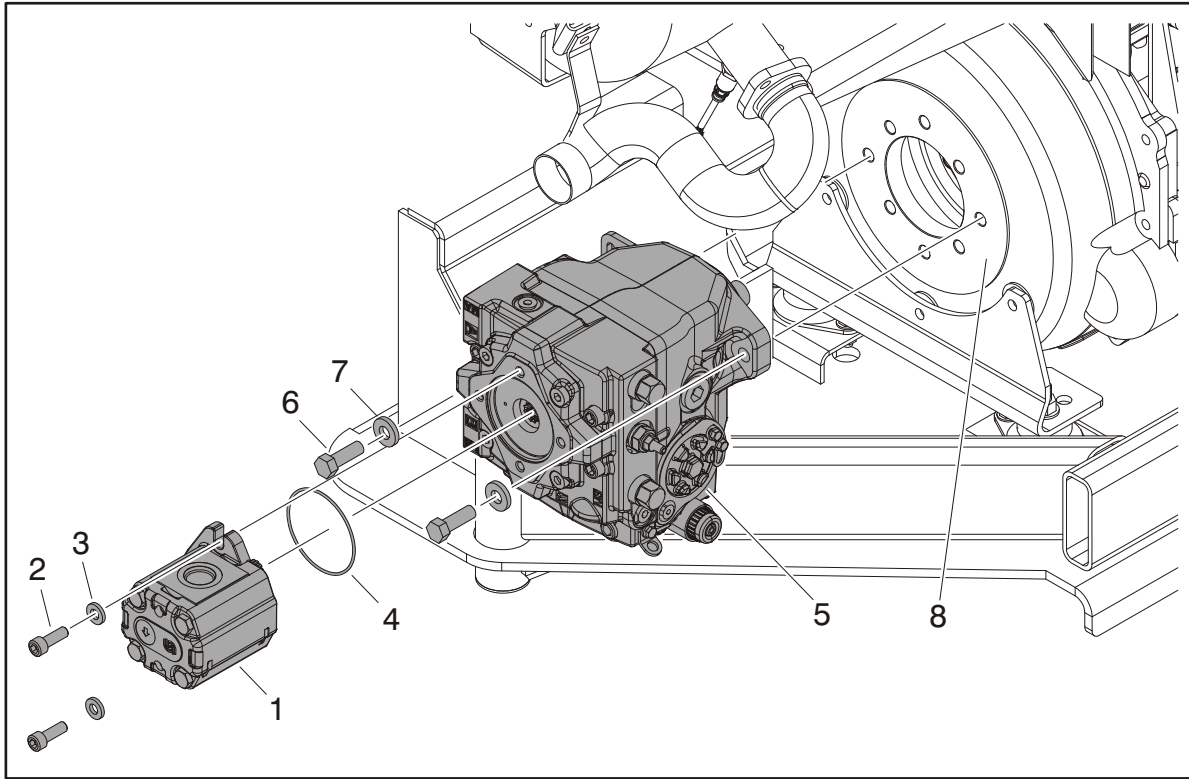

- | | | |
|-------------------------|-----------------------------|--------------------|
| 1. Gear Pump | 4. O-ring | 7. Washer |
| 2. Bolt, 3/8"-16NC x 1" | 5. Axial HI 45 Pump | 8. Coupling Flange |
| 3. Washer | 6. Bolt, 1/2"-13NC x 1 1/2" | |

Figure 3-76. Pump Assemblies (GM Engine)

CAUTION

ALLOW ENGINE AND COMPONENTS TO COOL DOWN BEFORE SERVICING.

REMOVAL:

1. Disable machine operation. Disconnect, cap and label all hydraulic hoses connected to pumps (1, 4). Disconnect and label all wiring connected to pumps.
2. Remove the two bolts (2) and washers (3) attaching the gear pump (1) to the axial pump (4). Carefully remove the gear pump.
3. Remove and discard the o-ring (4).
4. Remove the two bolts (5) and washers (6) attaching the axial pump to the flange (7) of the coupling. Carefully remove the axial pump.

INSTALLATION:

1. Follow Removal Steps in reverse.

NOTE: Apply Loctite® #242 to bolts (2, 5).

Apply grease to internal splines of pump coupling and external splines of axial pump (4) shaft prior to installing pump.

Install a new o-ring (4) during installation.

NOTE: Refer to Section 4.9, Gear Pump and Section 4.10, Axial HI 45 Pump for more information on pumps.

Pump Coupling

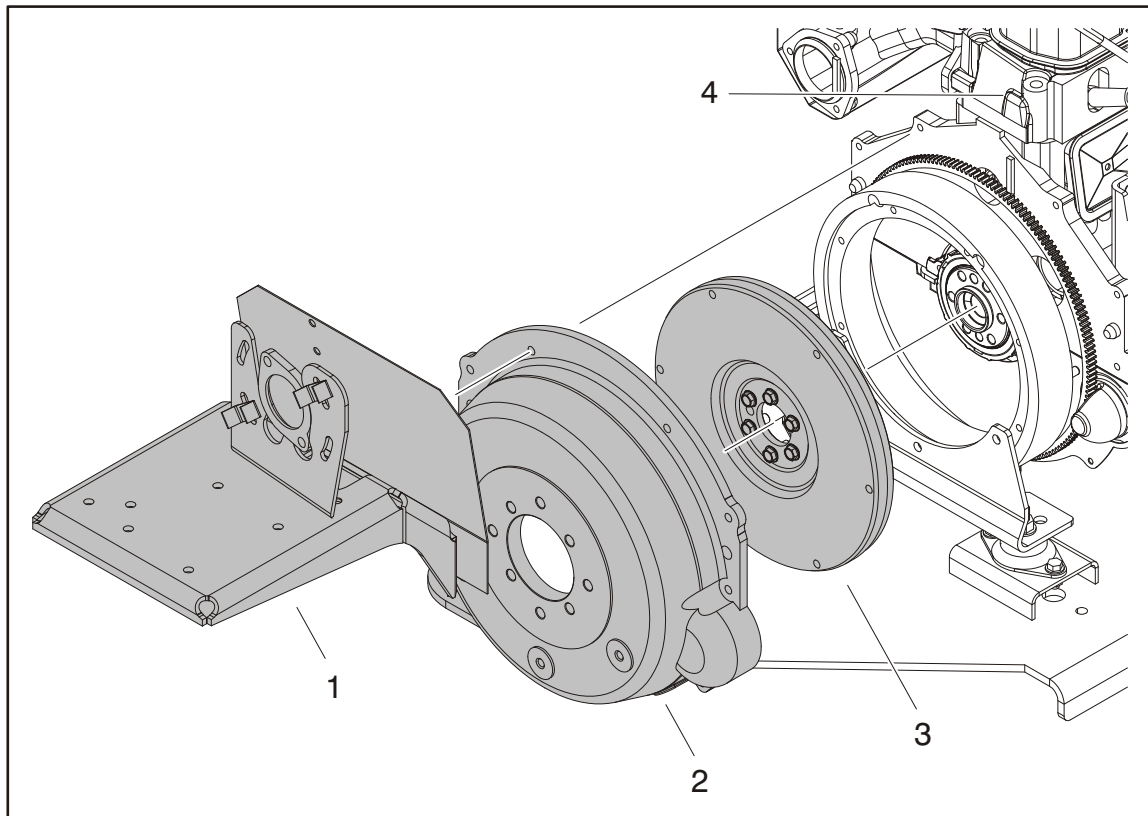

1. Muffler Mounting Bracket 2. Coupling Cover 3. Coupling 4. Engine

Figure 3-77. Pump Coupling (GM Engine)

⚠ CAUTION

ALLOW ENGINE AND COMPONENTS TO COOL DOWN BEFORE SERVICING.

REMOVAL:

1. Disable machine operation.
2. Remove exhaust system and pumps (refer to Figure 3-72. and Figure 3-76.).
3. Remove the bolts and washers to remove the muffler mounting bracket (1) from the coupling cover (2).
4. Remove the bolts on the coupling cover to remove the cover from the engine.
5. Remove the bolts on the coupling (3) to remove the coupling from the engine.

INSTALLATION:

1. Follow Removal Steps in reverse.

Engine Removal

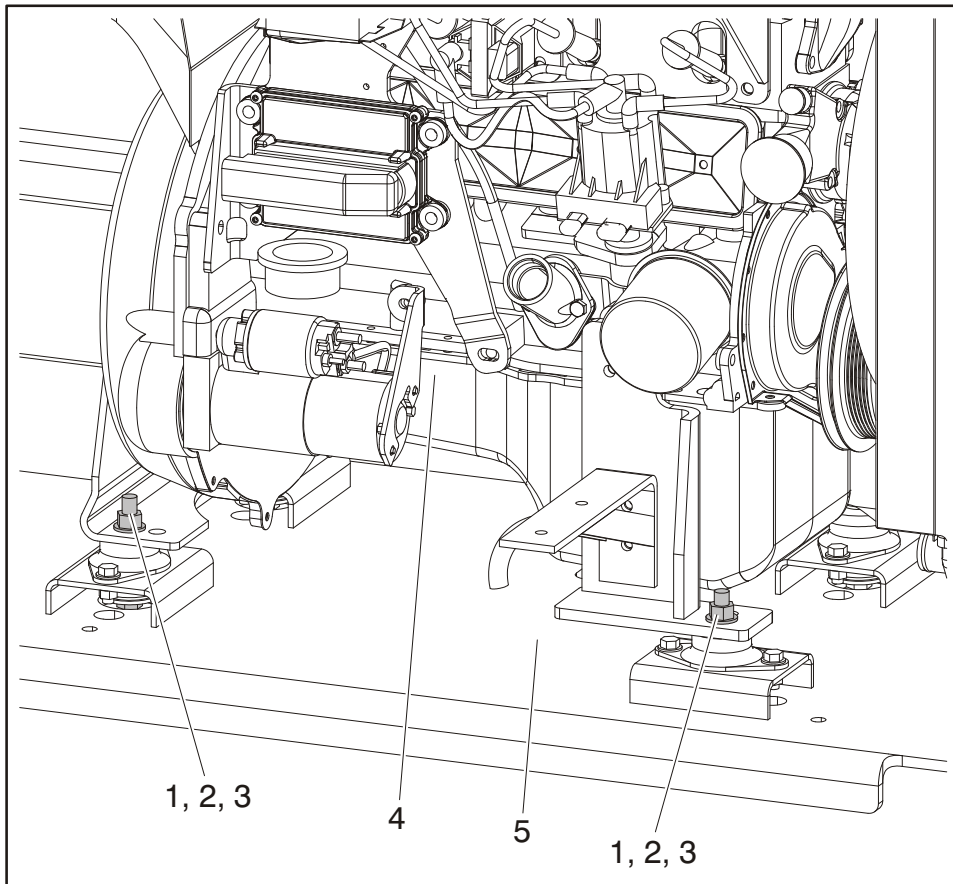

1. Bolt, 1/2"-13NC x 1 1/2"
2. Washer
3. Nut
4. Engine
5. Engine Tray

Figure 3-78. Engine Removal (GM Engine)

CAUTION

ALLOW ENGINE AND COMPONENTS TO COOL DOWN BEFORE SERVICING.

REMOVAL:

1. Disable machine operation.
2. Remove exhaust system, air cleaner system and hydraulic pumps (refer to Figure 3-72., Figure 3-73. and Figure 3-76.).
3. Disconnect, cap and label all hoses connected to engine (4). Disconnect and label all electrical wiring connected to engine.
4. Support engine with lifting device capable of lifting 500 lbs (227 kg) (refer to engine manual for proper lifting information).
5. Remove the bolts (1), washers (2) and nuts (3) at the four corners of the engine.

6. Slowly lift the engine up and out of the engine compartment.

NOTICE

BE CAREFUL NOT TO DAMAGE THE RADIATOR FAN ON THE RADIATOR HOUSING WHEN LIFTING THE ENGINE.

INSTALLATION:

1. Follow Removal Steps in reverse.

3.18 GM ENGINE DUAL FUEL SYSTEM

The Dual Fuel system allows the operator to operate the vehicle on either gasoline or LPG by positioning a selector switch on the platform control station. When the operator places the selector switch in the gasoline mode, the gasoline fuel pump is energized. While in the gasoline mode, the LPG fuel lock-off is isolated and will not energize. In addition, the gasoline injector circuit is enabled and injector pulses are provided to each injector and the ECM calibration for gasoline is also enabled. When the operator selects the LPG mode, the Low Pressure LPG lock-off is energized and fuel from the LPG tank flows to the Electronic Pressure Regulator (EPR). The EPR receives an electronic signal to position the secondary lever for the start or run positions and when the engine begins to crank, the mixer air valve will rise and fuel will begin flowing to engine. During this mode, the gasoline fuel pump is isolated and will not be activated. The primary components of the gasoline dual fuel system are the gasoline tank, electric fuel pump and filter, fuel supply line, injector rail and injectors and the fuel pressure regulator. The primary components of the LPG dual fuel system are the LPG fuel tank, in-fuel filter, LPG Low Pressure lock-off, EPR and the fuel mixer module. The LPG fuel system operates at pressures which range from 14.0 inches (355.60 mm) of water column up to 312 psi (21.5 bar).

Components which are shared by both systems include the Electronic Throttle Control and the ECM. The ECM contains a dual calibration; one controls the gasoline fuel system during gasoline operation and one controls the LPG fuel system during LPG operation.

Fuel Filter

Propane fuel like all other motor fuels is subject to contamination from outside sources. Refueling of the equipment's tank and removal of the tank from the equipment can inadvertently introduce dirt and other foreign matter into the fuel system. It is therefore necessary to filter the fuel prior to entering the fuel system components downstream of the tank. An inline fuel filter has been installed in the fuel system to remove the dirt and foreign matter from the fuel. The inline filter is replaceable as a unit only. Maintenance of the filter is critical to proper operation of the fuel system and should be replaced as specified in Section 1. In severe operating conditions, more frequent replacement of the filter may be necessary.

Electric Lock Off

The Electric Lock Off device is an integrated assembly. When energized, the solenoid opens the valve and allows the Propane fuel to flow through the device. The valve opens during cranking and run cycles of the engine. The

lock off supply voltage is controlled by the engine control module (ECM).

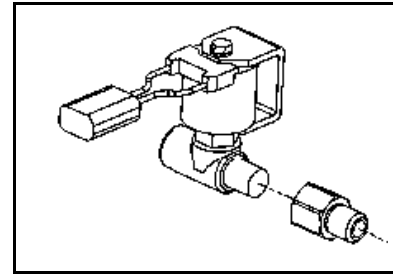
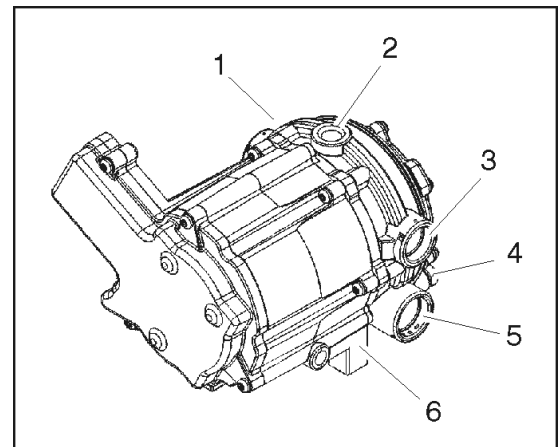

Figure 3-79. Electric Fuel Lock Off

Electronic Pressure Regulator Assembly

The EPR assembly is a combination Low Pressure Regulator and a Voice Coil Assembly. The Voice Coil is an electronic actuator which is controlled by an internal microprocessor. The microprocessor provides output data to the ECM and receives input data over a CAN BUS connection. The internal microprocessor receives electrical signals from the Fuel Pressure Sensor (FPS) and the Fuel Temperature Pressure FTP and communicates the data to the ECM. The ECM uses the FPS and FTP data to calculate the location of the secondary lever in the LPR and sends that data back to the EPR via the CAN BUS. The internal microprocessor in the EPR will then output a signal, which causes the voice coil to move and position the secondary lever to the correct location.



- | | |
|-------------------------------|------------------------|
| 1. Pressure Regulator Section | 4. Primary Test Port |
| 2. Fuel Inlet | 5. Secondary Test Port |
| 3. Coolant Passage | 6. Voice Coil Section |

Figure 3-80. EPR Assembly

Low Pressure Regulator (LPR)

The LPR is a combination vaporizer, pressure regulating device. The LPR is a negative pressure, two stage regulator that is normally closed when the engine is not running. When the engine is cranking or running, a partial vacuum is created in the fuel line which connects the regulator to the mixer. This partial vacuum opens the regulator permitting fuel to flow to the mixer.

Propane fuel enters the primary port of the LPR and passes through the primary jet and into the primary/exchanger chamber. As the propane passes through the heat exchanger, the fuel expands and creates pressure inside the chamber. The pressure rises as the fuel expands. When the pressure rises above 1.5 psi (0.103 bar), sufficient pressure is exerted on the primary diaphragm to cause the diaphragm plate to pivot and press against the primary valve pin, thus closing off the flow of fuel. This action causes the flow of fuel into the regulator to be regulated.

When the engine is cranking, sufficient vacuum will be introduced into the secondary chamber from the mixer drawing the secondary diaphragm down onto the spring loaded lever and opening the secondary valve allowing vaporized fuel to pass to the mixer. This mechanical action, in conjunction with the EPR reactions, causes the downward action on the secondary lever, causing it to open wider allowing more fuel to flow to the mixer.

⚠ WARNING

THE VOICE COIL SECTION OF THE EPR ASSEMBLY IS AN EMISSIONS CONTROL DEVICE AND CANNOT BE REBUILT. IF THE COIL ASSEMBLY FAILS TO OPERATE PROPERLY, REPLACE IT WITH AN OEM REPLACEMENT PART ONLY.

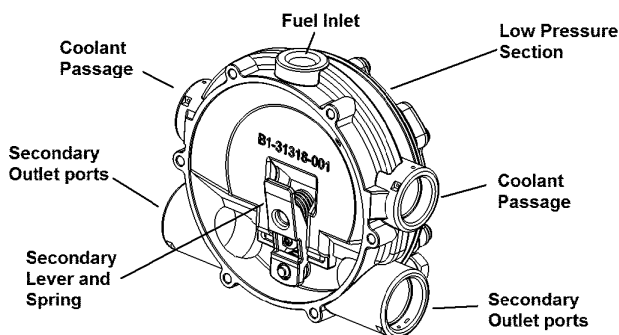

Figure 3-81. Low Pressure Regulators

Air Fuel Mixer

The air valve mixer is an air-fuel metering device and is completely self-contained. The mixer is an air valve design, utilizing a relatively constant pressure drop to draw fuel into the mixer from cranking to full load. The mixer is mounted in the air stream ahead of the throttle control device.

When the engine begins to crank, (it draws in air with the air valve covering the inlet) negative pressure begins to build. This negative pressure signal is communicated to the top of the air valve chamber through 4 vacuum ports in the air valve assembly. A pressure/force imbalance begins to build across the air valve diaphragm between the air valve vacuum chamber and the atmospheric pressure below the diaphragm. The air valve vacuum spring is calibrated to generate from 4.0 inches (101.6 mm) of water column at start to as high as 14.0 inches (355.60 mm) of water column at full throttle. The vacuum being created is referred to as Air Valve Vacuum (AVV). As the air valve vacuum reaches 4.0 inches (101.6 mm) of water column, the air valve begins to lift against the air valve spring. The amount of AVV generated is a direct result of the throttle position. At low engine speed, the air valve vacuum is low and the air valve position is low, thus creating a small venturi for the fuel to flow. As the engine speed increases, the AVV increases and the air valve is lifted higher, thus creating a much larger venturi. This AVV is communicated from the mixer venturi to the LPR secondary chamber via the low pressure fuel supply hose. As the AVV increases in the secondary chamber, the secondary diaphragm is drawn further down, forcing the secondary valve lever to open wider.

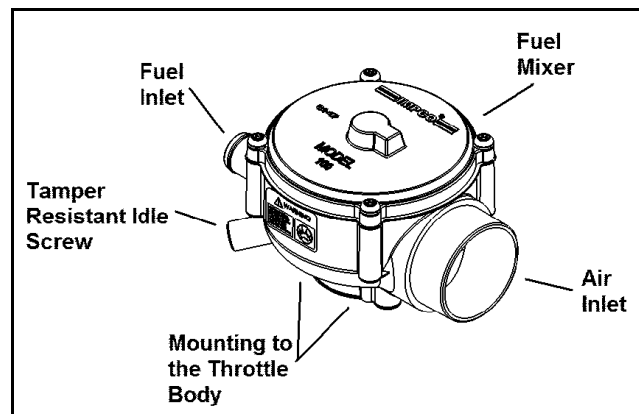

Figure 3-82. Air Fuel Mixer

Electronic Throttle Control (ETC)

Engine speed and load control is maintained by an ETC device. Speed and load control are determined by the ECM. Defaults programmed into the ECM software and throttle position sensors allow the ECM to maintain safe operating control over the engine. The Electronic Throttle Control device, or "throttle body assembly", is connected to the intake manifold of the engine. The ETC device utilizes an electric motor connected to the throttle shaft. When the engine is running, electrical signals are sent from the equipment controls to the engine ECM when the operator depresses an equipment function switch. The ECM then sends an electrical signal to the motor on the electronic throttle control to increase or decrease the angle of the throttle blade, thus increasing or decreasing the air/fuel flow to the engine.

The electronic throttle control device also incorporates two internal Throttle Position Sensors (TPS) which provide output signals to the ECM as to the location of the throttle shaft and blade. The TPS information is used by the ECM to correct speed and load control as well as emission control.

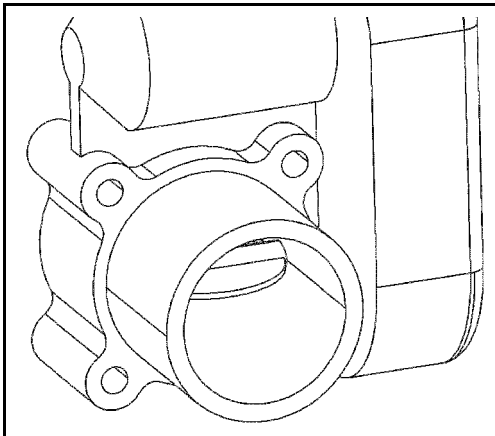

Figure 3-83. ETC throttle control device

Engine Control Module (ECM)

To obtain maximum effect from the catalyst and accurate control of the air fuel ratio, the emission certified engine is equipped with an onboard computer or ECM. The ECM is a 32 bit controller which receives input data from sensors fitted to the engine and fuel system and then outputs various signals to control engine operation.

One specific function of the controller is to maintain "closed loop fuel control". Closed loop fuel control is accomplished when the exhaust gas oxygen sensor (HEGO) mounted in the exhaust system sends a voltage signal to the controller. The controller then calculates any correction that may need to be made to the air fuel ratio. The controller then outputs signals to the EPR to correct the amount of fuel being supplied to the mixer. At the same time, the ECM may correct the throttle blade position to correct the speed and load of the engine.

The controller also performs diagnostic functions on the fuel system and notifies the operator of malfunctions by turning on a Malfunction Indicator Light (MIL) mounted in the Ground Control Station and the Platform Control Station. Malfunctions in the system are identified by a Diagnostic Code number. In addition to notifying the operator of the malfunction in the system, the controller also stores the information about the malfunction in its memory.

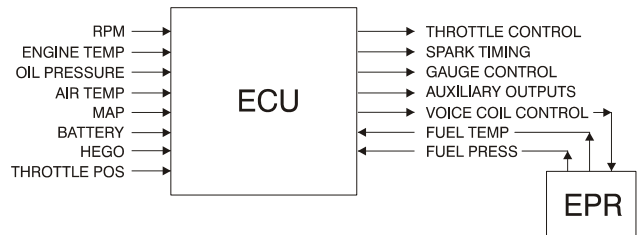

Figure 3-84. LPG Engine Control Unit (ECM)

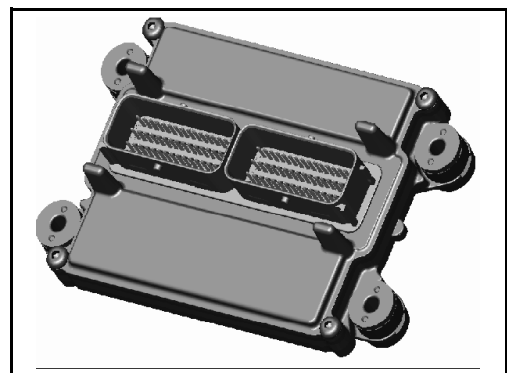

Figure 3-85. ECM Assembly

Heated Exhaust Gas Oxygen Sensor (HEGO)

There are two Heated Exhaust Gas Oxygen Sensors (HEGO). The first HEGO is mounted in the exhaust system downstream of the engine. It is used to measure the amount of oxygen present in the exhaust stream and communicate that to the ECM via an electrical signal. The amount of oxygen present in the exhaust stream indicates whether the fuel/air ratio is too rich or too lean. If the HEGO sensor signal indicates that the exhaust stream is too rich, the ECM will decrease or lean the fuel mixture during engine operation. If the mixture is too lean, the ECM will richen the mixture. The ECM continuously monitors the HEGO sensor output. If a rich or lean condition is present for an extended period of time and the ECM cannot correct the condition, the ECM will set a diagnostic code and turn on the MIL light in the control box.

The second HEGO is mounted in the exhaust system after the muffler. It measures the amount of oxygen in the exhaust system after the catalyst treatment has been completed in the muffler. If the ECM detects that the catalytic action in the muffler is not sufficient and fuel correction cannot correct the malfunction, the MIL light is illuminated in the control box and a DTC code will be stored in the computer.

⚠ CAUTION

THE HEATED EXHAUST GAS OXYGEN SENSOR IS AN EMISSION CONTROL DEVICE. IF THE HEGO FAILS TO OPERATE, REPLACE IT WITH AN OEM REPLACEMENT PART. THE HEGO SENSOR IS SENSITIVE TO SILICONE OR SILICONE BASED PRODUCTS AND CAN BECOME CONTAMINATED. AVOID USING SILICONE SEALERS OR HOSES TREATED WITH SILICONE LUBRICANTS IN THE AIR STREAM OR FUEL LINES.



Figure 3-86. Heated Exhaust Gas Oxygen Sensor (HEGO)

Gasoline Multi Point Fuel Injection System (MPFI)

The primary components of the Gasoline Multi Point Fuel Injection (MPFI) fuel system are the fuel tank, electric fuel pump, fuel pressure and temperature sensor manifold, fuel filter and fuel rail.

Gasoline Fuel Pump

The Gasoline is stored as a liquid in the fuel tank and is drawn into the fuel system by an electric fuel pump. The fuel pump will receive a signal from the ECM to prime the fuel system for approximately 2 seconds prior to start. Priming of the fuel system provides for a quicker start when the engine begins to crank.

Gasoline Pressure And Temperature Sensor Manifold

This engine is equipped with a fuel injector rail that does not have a pressure regulator or a return circuit to the fuel tank. Fuel pressure for this engine is regulated by the engine's ECM. The ECM receives fuel pressure and temperature feedback from the gasoline fuel sensor manifold and uses this information to control the ground side of the fuel pump. Fuel pressure is regulated by the ECM pulse width modulating (PWM) the fuel pump. The fuel pressure and temperature sensor manifold has a return, or "bleed", circuit that connects back to the fuel tank. This circuit is used to bleed off any vapor that develops in the line and return a small amount of fuel to the tank. The fuel comes from the fuel tank and passes through the fuel pump. Fuel exits the fuel pump, passes through the filter and then enters the fuel pressure and temperature manifold assembly. Fuel flows through the feed circuit and is delivered to the fuel injector rail. Fuel that enters the bleed circuits through the bypass valve in the manifold is returned to the fuel tank.

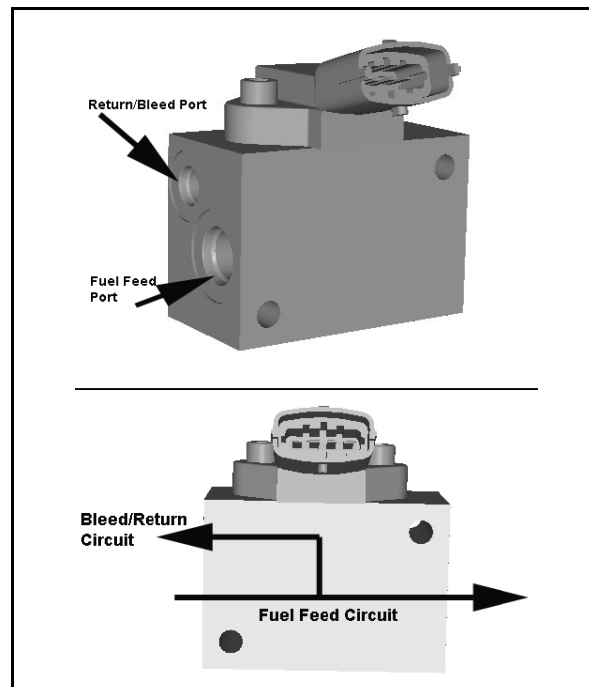

Figure 3-87. Gasoline Fuel Pressure and Temperature Manifold Assembly

Fuel Filter

After the fuel is drawn into the fuel pump, the fuel flows through the gasoline fuel filter. The fuel filter will trap small particles as the fuel passes through the filter to remove debris and prevents the fuel pressure and temperature manifold and fuel injectors from becoming damaged. Maintenance of the fuel filter is required as indicated in Section 1.

Fuel Injector Rail

Fuel flows from the fuel pressure and temperature manifold assembly to the fuel rails where the fuel is delivered to the fuel injectors. The fuel rail also contains a Schrader valve which is utilized to test the regulated pressure of the fuel system.

Fuel Injector

The fuel supply is maintained on the top of the injector from the injector rail. The injector is fed a "pulse" signal through the wire harness which causes the injector to open. During regular operating conditions, the ECM controls the opening and duration of opening of the injector. During lower RPM operation, the injector signals, or "pulses", are less frequent than when the engine is operating at higher RPMs. The engine has been calibrated to deliver the precise amount of fuel for optimum performance and emission control.

3.19 GM ENGINE FUEL SYSTEM REPAIR

Propane Fuel System Pressure Relief

CAUTION

THE PROPANE FUEL SYSTEM OPERATES AT PRESSURES UP TO 312 PSI (21.5 BAR). TO MINIMIZE THE RISK OF FIRE AND PERSONAL INJURY, RELIEVE THE PROPANE FUEL SYSTEM PRESSURE (WHERE APPLICABLE) BEFORE SERVICING THE PROPANE FUEL SYSTEM COMPONENTS.

To relieve propane fuel system pressure:

1. Close the manual shut-off valve on the propane fuel tank.
2. Start and run the vehicle until the engine stalls.
3. Turn the ignition switch OFF.

NOTICE

RESIDUAL VAPOR PRESSURE WILL BE PRESENT IN THE FUEL SYSTEM. ENSURE THE WORK AREA IS WELL VENTILATED BEFORE DISCONNECTING ANY FUEL LINE.

Propane Fuel System Leak Test

CAUTION

NEVER USE AN OPEN FLAME OF ANY TYPE TO CHECK FOR PROPANE FUEL SYSTEM LEAKS.

Always inspect the propane fuel system for leaks after performing service. Check for leaks at the fittings of the serviced or replaced component. Use a commercially available liquid leak detector or an electronic leak detector. When using both methods, use the electronic leak detector first to avoid contamination by the liquid leak detector.

Propane Fuel Filter Replacement

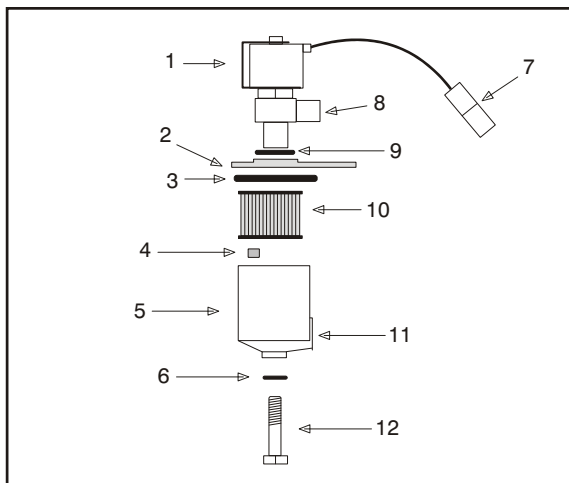

- | | |
|-------------------------------|-------------------------|
| 1. Electric Lock Off Solenoid | 7. Electrical Connector |
| 2. Mounting Plate | 8. Fuel Outlet |
| 3. Housing Seal | 9. O-ring |
| 4. Filter Magnet | 10. Filter |
| 5. Filter Housing | 11. Fuel Inlet |
| 6. Seal | 12. Retaining Bolt |

Figure 3-88. Filter Lock Assembly

REMOVAL:

1. Relieve the propane fuel system pressure. Refer to Propane Fuel System Pressure Relief.
2. Disconnect the negative battery cable.
3. Slowly loosen the filter housing retaining bolt and remove it.
4. Pull the filter housing from the Electric lock off assembly.
5. Locate Filter magnet and remove it.
6. Remove the filter from the housing.
7. Remove and discard the housing seal.
8. Remove and discard the retaining bolt seal.
9. Remove and discard the mounting plate to lock off O-ring seal.

INSTALLATION:

NOTICE

BE SURE TO REINSTALL THE FILTER MAGNET INTO THE HOUSING BEFORE INSTALLING NEW SEAL.

1. Install the mounting plate to lock off O-ring seal.
2. Install the retaining bolt seal.

3. Install the housing seal.
4. Drop the magnet into the bottom of the filter housing.
5. Install the filter into the housing.
6. Install the retaining bolt into the filter housing.
7. Install the filter up to the bottom of the electric lock off.
8. Tighten the filter retaining bolt to 106 in.lbs. (12 Nm).
9. Open manual shut-off valve. Start the vehicle and leak check the propane fuel system at each serviced fitting. Refer to Propane Fuel System Leak Test.

Electronic Pressure Regulator (EPR) Assembly Replacement

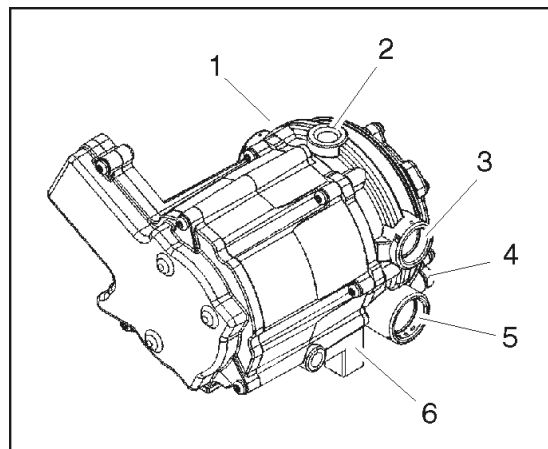

- | | |
|-------------------------------|------------------------|
| 1. Pressure Regulator Section | 4. Primary Test Port |
| 2. Fuel Inlet | 5. Secondary Test Port |
| 3. Coolant Passage | 6. Voice Coil Section |

Figure 3-89. EPR Assembly

The EPR assembly is made up of two separate components. The Voice Coil Section is not serviceable and can only be replaced as an assembly. The pressure regulator section is serviceable and will be detailed in this section.

REMOVAL:

1. Relieve the propane fuel system pressure. Refer to Propane Fuel System Pressure Relief.
2. Disconnect the negative battery cable.
3. Slowly remove the fuel inlet fitting at the Electric Lock Off.

NOTE: Residual vapor pressure will be present in the fuel system.

4. Disconnect the electrical connector from the Electric Lock off.
5. Remove the Electric Lock Off from the regulator.
6. Remove the lock pin from the vapor fitting on the regulator housing. Remove the fitting and hose and retain the pin.
7. Remove the lock pin from the pressure sensor on the regulator housing. Remove the sensor and retain the pin.
8. Using clamp pliers, pinch off the hoses on the coolant lines to the regulator.
9. Remove the lock pin from both water fittings on the regulator housing. Remove the fittings and hoses and retain the pin.
10. Disconnect the EPR electrical connector.
11. Remove the three nuts from the EPR isolators and the EPR mounting bracket.
12. Remove the EPR from the bracket.
13. Remove the three mounting isolators.

INSTALLATION:

NOTICE

DO NOT USE TEFLON TAPE ON ANY FUEL FITTING. USE A LIQUID PIPE THREAD SEALANT WHEN INSTALLING FITTINGS.

CHECK ALL THE O-RINGS ON THE VAPOR AND WATER FITTINGS FOR ANY DAMAGE. REPLACE IF NECESSARY.

LUBE ALL THE O-RINGS WITH AN O-RING LUBE BEFORE INSTALLING.

1. Install the three rubber isolators to the bottom of the EPR.
2. Install the EPR assembly to the bracket and tighten the retaining nuts.

NOTE: Do not overtighten the isolators and cause a separation of the isolators.

3. Install the fuel temperature sensor into the regulator opening and lock in place with the locking pin. Connect the electrical connector.
4. Insert the fuel vapor line and fitting into the regulator port and lock in place with the locking pin.
5. Install both the water hoses and fittings into the regulator and lock in place with the locking pin. Remove the clamp pliers from the hoses.
6. Install the electric lock off into the regulator inlet and tighten into proper location. Connect the electrical connector.

7. Connect the fuel supply line and tighten until fully seated.
8. Connect the EPR electrical connector.
9. Open the manual valve.
10. Start the vehicle and leak check the propane fuel system at each serviced fitting. Refer to Propane Fuel System Leak Test.

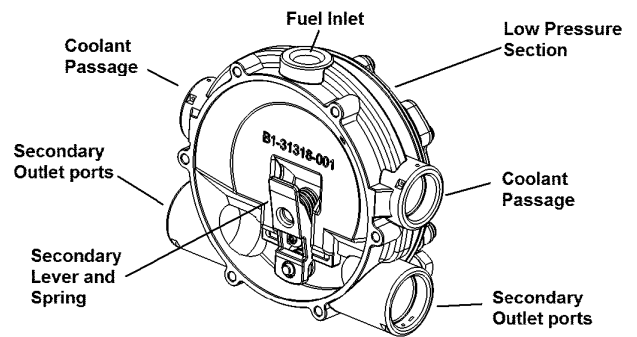

Figure 3-90. Pressure Regulator Section

PRESSURE REGULATOR SECTION REMOVAL:

1. Remove the EPR. Refer to EPR Removal Procedure.
2. Remove the six regulator to voice coil screws using the special tool and separate the regulator from the actuator.

NOTICE

DO NOT REMOVE THE SECONDARY DIAPHRAGM RETAINING PLATE AND DIAPHRAGM. THIS WILL VOID THE WARRANTY OF THE ACTUATOR SECTION.

PRESSURE REGULATOR SECTION INSTALLATION:

1. Install the regulator to the actuator section using the six retaining screws and tighten to 70 in.lbs. (8 Nm).
2. Install the EPR. Refer to EPR Installation.

Temperature Manifold Absolute Pressure (TMAP) Sensor

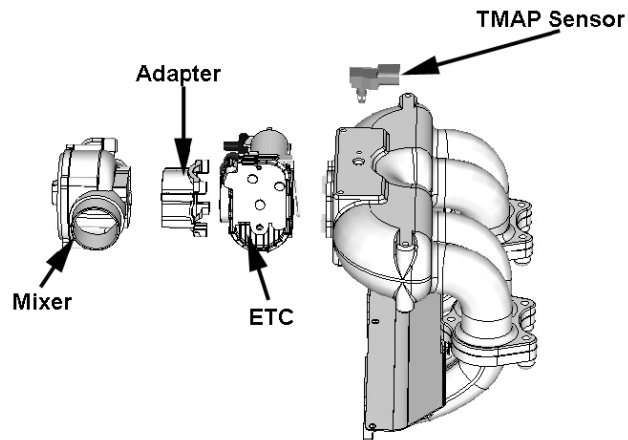

Figure 3-91. (TMAP) Sensor & Electronic Throttle Control (ETC)

REMOVAL:

1. Disconnect the TMAP electrical connector.
2. Remove the two retaining bolts.
3. Remove the TMAP.

INSTALLATION:

NOTE: Apply a small amount of O-ring lubricant before installation.

1. Install in the TMAP.
2. Tighten retaining bolts to 62 lb-in (7 Nm).
3. Start the vehicle and check for proper operation.

Electronic Throttle Control Replacement

See Figure 3-91.

REMOVAL:

1. Disconnect the negative battery cable.
2. Remove the air intake duct.
3. Release the hose clamp on the vapor fuel line and remove the vapor hose.
4. Disconnect the TMAP electrical connector.
5. Disconnect the electronic throttle control connector.
6. Remove the manifold to throttle body adapter bolts and remove the throttle body mixer assembly.
7. Pull the throttle body assembly from the adapter.
8. Remove electronic throttle control device.
9. Remove the O-rings gasket and discard.

INSTALLATION:

NOTICE

LIGHTLY LUBRICATE BOTH THROTTLE CONTROL DEVICE TO ADAPTER O-RINGS.

1. Install the O-ring on throttle body. Press it down to the bottom of the surface.

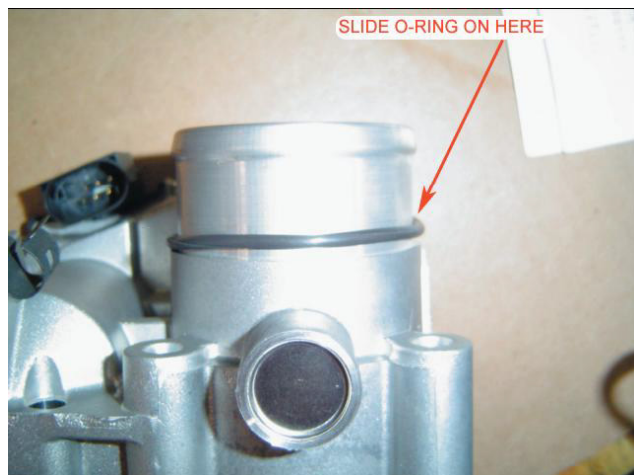

2. Install the two quad seals. Install one seal at a time to ensure the seal does not roll. The seal must sit flat on the throttle body.



3. Attach mixer and throttle body together. The two parts do not bolt together; they will be secured when you mount it on the intake. Notice the orientation of the air inlet and throttle body cover.

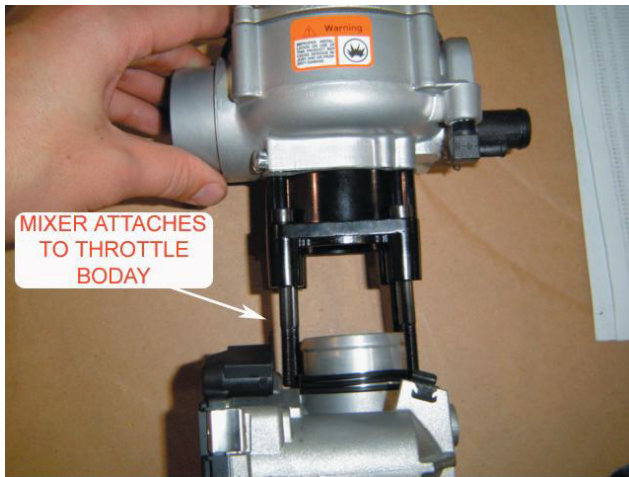

4. Place gasket on intake manifold and attach mixer/throttle assembly to manifold.

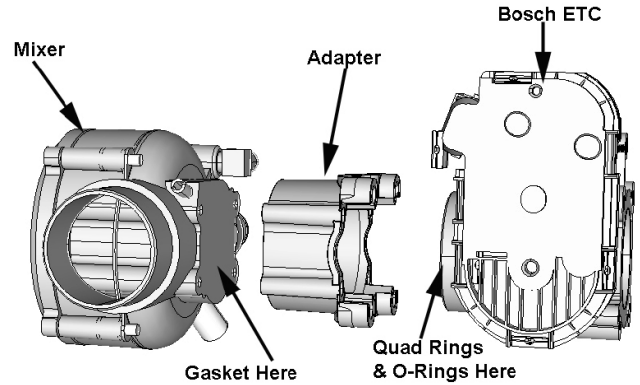

Figure 3-92. Mixer Assembly

Mixer Replacement

See Figure 3-92.

REMOVAL:

1. Remove the throttle control device. Refer to Electronic Throttle Body Replacement.
2. Remove the four (4) bolts to the throttle control device to mixer adapter bolts.
3. Remove and discard the gasket between the mixer and adapter.

INSTALLATION:

NOTICE

COVER THROTTLE BODY ADAPTER OPENING TO PREVENT DEBRIS FROM ENTERING ENGINE UNTIL REASSEMBLY.

1. Install the gasket onto the mixer.
2. Install the mixer to the throttle control device to mixer adapter. Secure with 4 retaining screws. Tighten 80 lb-in (9 Nm).
3. Install throttle body. Refer to Electronic Throttle Control Device Replacement.
4. Start the engine and leak check all fittings and connections.

Coolant Hose Replacement

REMOVAL:

1. Drain the coolant into an appropriate container.
2. Using hose clamp pliers, disconnect both hose clamps on each hose.
3. Remove the hose from each of the fittings.

INSTALLATION:

NOTE: Use hose material and lengths specified by JLG.

1. Install the hose clamps to each hose and set the clamp back on each hose to make installation easier.
2. Fit the hose to the fittings.
3. Secure by positioning each of the clamps.

Vapor Hose Replacement

REMOVAL:

1. Using hose clamp pliers, disconnect both hose clamps.
2. Remove the vapor hose from each fitting.

INSTALLATION:

NOTICE

THE VAPOR SUPPLY HOSE IS SPECIFICALLY DESIGNED. DO NOT USE HOSE MATERIAL OR LENGTH OTHER THAN JLG SPECIFIED PARTS.

1. Install hose clamps and set back on each hose.
2. Reinstall the vapor hose to each fitting.
3. Reset clamps.
4. Start engine and check for leaks.

Engine Control Module Replacement

REMOVAL:

1. Disconnect Negative battery cable.
2. Remove controller from mounting bracket.
3. Push connector lock back to unlock connector.
4. Unplug controller and remove.

INSTALLATION:

NOTICE

THE CONTROLLER IS CALIBRATED FOR EACH ENGINE. VERIFY YOU HAVE THE CORRECT CONTROLLER

1. Plug connector into controller.
2. Push lock into place.
3. Mount controller into mounting bracket.
4. Reconnect battery cable.
5. Start engine.
6. Check for any DTC codes and clear.
7. Verify engine is in closed loop and no warning lights are illuminated.

Heated Exhaust Gas Oxygen Sensor Replacement

REMOVAL:

1. Disconnect Negative battery cable.
2. Disconnect the O2 sensor electrical connector.
3. Using an O2 Sensor socket, remove the O2 Sensor and discard.

INSTALLATION:

NOTICE

BEFORE INSTALLING THE O2 SENSOR, LUBRICATE THREADS WITH ANTI-SEIZE COMPOUND GM P/N 5613695 OR EQUIVALENT. AVOID GETTING COMPOUND ON THE SENSOR TIP.

1. Install O2 sensor. Tighten to 30 lb-ft (41 Nm).
2. Start engine.
3. Check for any DTC codes and clear.
4. Verify engine is in closed loop and no warning lights are illuminated.

3.20 GM ENGINE LPG FUEL SYSTEM DIAGNOSIS

Fuel System Description

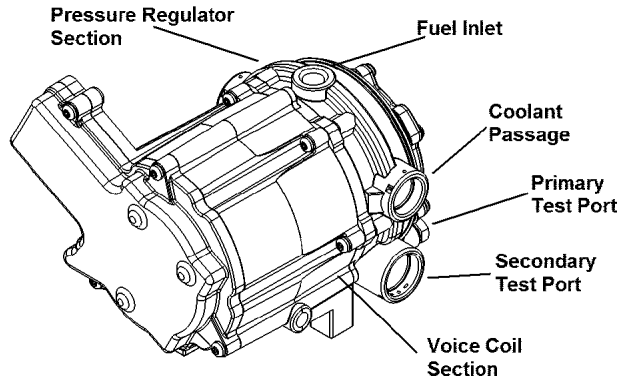

Figure 3-93. EPR Assembly

To maintain fuel and emission control on the LPG fuel system, the Engine Control Unit (ECM) relies on numerous engine sensor and output data from the Electronic Pressure Regulator (EPR). The ECM will then determine the target fuel calibration and command the EPR to reposition the voice coil to the proper position which, subsequently repositions the secondary lever in the pressure regulator to maintain proper control. The EPR and ECM will continue to communicate back and forth during normal operation.

In the event that the EPR fails to communicate or the Communications Area Network (CAN) cable fails to transmit data, the regulator will operate in an open loop configuration. As the air valve vacuum in the mixer venturi is communicated to the secondary chamber of the regulator, the secondary diaphragm will be drawn in a downwards motion. This downward motion will cause the secondary lever to open, thus allowing more fuel to enter the mixer.

In the (LPR), the fuel is vaporized and the pressure reduced in two stages. The first stage reduces the pressure to approximately 1.0 to 3.0 psi (6.8 to 20.6 kPa). The second stage reduces the pressure to approximately negative 1.5" of water column.

The fuel is then drawn from the secondary chamber of the LPR by the vacuum generated by air flowing through the mixer. This vacuum signal is also used to generate lift for the mixer air valve. This vacuum signal is most commonly referred to as air valve vacuum. In the mixer, the fuel mixes with the air entering the engine. This air/fuel mixture is then drawn into the engine for combustion.

Diagnostic Aids

This procedure is intended to diagnose a vehicle operating on LPG. If the vehicle will not continue to run on LPG, refer to Hard Start for preliminary checks. Before proceeding with this procedure, verify that the vehicle has a sufficient quantity of fuel and that liquid fuel is being delivered to the LPR. Also, ensure that the manual shut off valve on the LPG tank is fully opened and that the excess flow valve has not been activated.

Tools Required:

- 7/16 Open end wrench (for test port plugs)
- DVOM (GM J 39200, Fluke 88 or equivalent)
- 12 volt test light

Diagnostic Scan Tool:

- Diagnostic Display tool

Pressure Gauges:

- IMPCO ITK-2 Test kit
- Water Column Gauge / Manometer (GM 7333-6 or equivalent)
- 0-10 PSI Gauge

Test Description:

The numbers below refer to step numbers in Table 3-15, LPF Fuel System Diagnosis.

5. This step determines if the LPR requires replacement.
6. This step determines if the problems are in the mechanical side of the Pressure Regulator or the Electronic Voice Coil.
10. This step determines if the Mixer requires replacement.
14. This step determines if the Lock Off requires replacement.
17. This step determines if the Fuel Filter requires replacement.

SECTION 3 - CHASSIS, PLATFORM & SCISSOR ARMS

Table 3-15. LPF Fuel System Diagnosis

STEP	ACTION	VALUE(S)	YES	NO
1	Were you referred to this procedure by a DTC diagnostic chart?	--	Go to Step 3	Go to Step 2
2	Perform the On Board Diagnostic (OBD) System Check. Are any DTCs present in the ECM?	--	Go to the applicable DTC Table	Go to Step 3
3	Verify that the LPG fuel tank has a minimum of 1/4 tank of fuel, that the manual valve is open and the tank quick connect is fully engaged. Does the vehicle have fuel?	--	Go to Step 4	--
4	1. Connect a water column gauge or a manometer to the secondary test port of the low pressure regulator (LPR). 2. Start the engine and allow it to reach operating temperature. Does the engine start and run?	--	Go to Step 5	Go to Step 8
5	With the engine idling, observe the pressure reading for the LPR secondary pressure. Does the fuel pressure fluctuate rhythmically OUTSIDE the specified range?	-1.0" to -2.0" w.c	Go to Step 25	Go to Step 6
6	1. Disconnect the EPR electrical connectors. NOTE: This action will cause a DTC to be set by the ECM. 2. With the engine idling, observe the pressure reading on the secondary test port. Is the fuel pressure WITHIN the specified range?	-1.0" to -2.0" w.c	Go to Fuel Control System Diagnosis	Go to Step 7
7	1. Inspect the air intake stream between the mixer assembly and the throttle body for leaks. 2. Inspect the fuel hose connection between the LPR and mixer assembly for damage or leakage. 3. Inspect any vacuum hoses for leaks. Was a problem found and corrected?	--	Go to Step 26	Go to Step 22
8	1. Connect a water column gauge or a manometer to the secondary test port of the low pressure regulator (LPR). 2. Crank the engine and observe the pressure reading for the LPR secondary pressure. Does the fuel pressure indicate a vacuum is present?	--	Go to Step 12	Go to Step 9
9	1. Remove Air induction hose to the mixer. 2. Observe the air valve for movement while the engine is cranking. Note: Movement of the air valve will be minimal at cranking speeds. Does the air valve move when the engine is cranked?	--	Go to Step 11	Go to Step 10
10	1. Inspect the air intake stream to the mixer assembly and the throttle body for vacuum leaks. 2. Inspect the vacuum hoses from the mixer for proper connection and condition. Was a problem found and repaired?	--	Go to Step 26	Go to Step 24
11	Inspect the fuel hose connection between the LPR and the mixer assembly for damage or leakage. Was a problem found and repaired?	--	Go to Step 26	Go to Step 12
12	1. Connect a 0-10 psi gauge to the primary test port of the low pressure regulator (LPR). 2. Crank the engine and observe the pressure reading for the LPR primary pressure. Is the fuel pressure ABOVE the specified value?	1-3 PSI	Go to Step 22	Go to Step 13

SECTION 3 - CHASSIS, PLATFORM & SCISSOR ARMS

Table 3-15. LPF Fuel System Diagnosis

STEP	ACTION	VALUE(S)	YES	NO
13	1. Turn OFF the ignition. 2. Disconnect the LPL connector. 3. Install a test light between the pins of the LPL connector. 4. Crank the engine. The test light should illuminate. Does the test light illuminate?	--	Go to Step 14	Go to Step 16
14	Using a DVOM, check the resistance of the low pressure lock-off (LPL). Is the resistance within the specified range?	12W - 16W	Go to Step 15	Go to Step 23
15	1. Turn the ignition OFF. 2. Close the manual shut-off valve on the LPG tank. CAUTION: When disconnecting LPG fuel lines, liquid LPG may be present. Perform this step in a well ventilated area. 3. Loosen the fuel inlet hose fitting at the inlet of the LPL. Was fuel present when the fitting was loosened?	--	Go to Step 23	Go to Step 17
16	1. Turn OFF the ignition. 2. Connect the test light to chassis ground and probe pin A of the LPL connector. 3. Crank the engine. The test light should illuminate. Does the test light illuminate?	--	Go to Step 20	Go to Step 21
17	1. Remove the LPG fuel filter / LPL. 2. Remove the filter from the LPL. 3. Empty the contents of the inlet side of the LPG fuel filter onto a clean surface. 4. Inspect the contents of the LPG fuel filter for an excessive amount of foreign material or water. If necessary, locate and repair the source of contamination. 5. Verify the LPG fuel filter is not restricted or plugged. Was a problem found?	--	Go to Step 19	Go to Step 18
18	The fuel supply system or hoses are plugged or restricted, locate and repair the problem. Is the action complete?	--	Go to Step 26	--
19	Replace the fuel filter. Refer to Fuel Filter Replacement. Is the action complete?	--	Go to Step 26	--
20	Repair the open in the lock-off ground circuit. Is the action complete?	--	Go to Step 26	--
21	Repair the open in the lock-off power circuit. Is the action complete?	--	Go to Step 26	--
22	Replace the low pressure regulator (LPR). Refer to Low Pressure Regulator Replacement. Is the action complete?	--	Go to Step 26	--
23	Replace the lock-off. Refer to Lock-off Replacement. Is the action complete?	--	Go to Step 26	--
24	Replace the mixer assembly. Refer to Fuel Mixer Replacement. Is the action complete?	--	Go to Step 26	--

SECTION 3 - CHASSIS, PLATFORM & SCISSOR ARMS

Table 3-15. LPF Fuel System Diagnosis

STEP	ACTION	VALUE(S)	YES	NO
25	<p>The fuel supply system is operating normally, if a failure of the control solenoids is suspected. Refer to Fuel Control System Diagnosis.</p> <p>1. Install the test plug in the LPR secondary chamber. 2. If you were sent to this routine by another diagnostic chart, return to the previous diagnostic procedure. Is the action complete?</p>	--	System OK	--
26	<p>1. Disconnect all test equipment. 2. Install the primary and secondary test port plugs. 3. Start the engine. 4. Using SNOOP or equivalent, leak check the test port plugs. Is the action complete?</p>	--	System OK	--

Table 3-16. Symptom Diagnosis

Checks	Action
Important Preliminary Checks	
Before Using This Section	<p>Before using this section, you should have performed On Board Diagnostic Check and determined that:</p> <ol style="list-style-type: none"> 1. The Control Module and MIL (Malfunction Indicator Lamp) are operating correctly. 2. There are no Diagnostic Trouble Codes (DTCs) stored, or a DTC exists but without a MIL. <p>Several of the following symptom procedures call for a careful visual and physical check. The visual and physical checks are very important. The checks can lead to correcting a problem without further checks that may save valuable time.</p>
LPG Fuel System Check	<ol style="list-style-type: none"> 1. Verify the customer complaint. 2. Locate the correct symptom table. 3. Check the items indicated under that symptom. 4. Operate the vehicle under the conditions the symptom occurs. Verify HEGO switching between lean and rich. <p>Important: Normal HEGO switching indicates the LPG fuel system is in closed loop and operating correctly at that time.</p>
Visual and Physical Checks	<ul style="list-style-type: none"> • Check all ECM system fuses and circuit breakers. • Check the ECM ground for being clean, tight and in its proper location. • Check the vacuum hoses for splits, kinks and proper connections. • Check thoroughly for any type of leak or restriction. • Check for air leaks at all the mounting areas of the intake manifold sealing surfaces. • Check for proper installation of the mixer module assembly. • Check for air leaks at the mixer assembly. • Check the ignition wires for the following conditions: <ul style="list-style-type: none"> - Cracking - Hardness - Proper routing - Carbon tracking • Check the wiring for the following items: <ul style="list-style-type: none"> - Proper connections, pinches or cuts • The following symptom tables contain groups of possible causes for each symptom. The order of these procedures is not important. If the scan tool readings do not indicate the problems, then proceed in a logical order, easiest to check or most likely to cause first.
Intermittent	
DEFINITION: The problem may or may not turn ON the Malfunction Indicator Lamp (MIL) or store a Diagnostic Trouble Code (DTC).	
Preliminary Checks	<ul style="list-style-type: none"> • Refer to Important Preliminary Checks. • Do not use the DTC tables. If a fault is an intermittent, the use of the DTC tables may result in the replacement of good parts.
Faulty Electrical Connections or Wiring	<ul style="list-style-type: none"> • Faulty electrical connections or wiring can cause most intermittent problems. • Check the suspected circuit for the following conditions: <ul style="list-style-type: none"> - Faulty fuse or circuit breaker - Connectors poorly mated - Terminals not fully seated in the connector (backed out) - Terminals not properly formed or damaged - Terminal to wires poorly connected - Terminal tension insufficient • Carefully remove all the connector terminals in the problem circuit in order to ensure the proper contact tension. If necessary, replace all the connector terminals in the problem circuit in order to ensure the proper contact tension. • Checking for poor terminal to wire connections requires removing the terminal from the connector body.
Operational Test	If a visual and physical check does not locate the cause of the problem, drive the vehicle with a scan tool. When the problem occurs, an abnormal voltage or scan reading indicates the problem may be in that circuit.

SECTION 3 - CHASSIS, PLATFORM & SCISSOR ARMS

Table 3-16. Symptom Diagnosis

Checks	Action
Intermittent Malfunction Indicator Lamp (MIL)	<p>The following components can cause intermittent MIL and no DTC(s):</p> <ul style="list-style-type: none"> • A defective relay, Control Module driven solenoid, or a switch that can cause electrical system interference. Normally, the problem will occur when the faulty component is operating. • The improper installation of electrical devices, such as lights, 2-way radios, electric motors, etc. • The ignition secondary voltage shorted to a ground. • The Malfunction Indicator Lamp (MIL) circuit or the Diagnostic Test Terminal intermittently shorted to ground. • The Control Module grounds.
Loss of DTC Memory	<p>To check for the loss of the DTC Memory:</p> <ol style="list-style-type: none"> 1. Disconnect the TMAP sensor. 2. Idle the engine until the Malfunction Indicator Lamp illuminates. <p>The ECM should store a TMAP DTC. The TMAP DTC should remain in the memory when the ignition is turned OFF. If the TMAP DTC does not store and remain, the ECM is faulty.</p>
No Start	
DEFINITION: The engine cranks OK, but does not start.	
Preliminary Checks	Refer to Important Preliminary Checks.
Control Module Checks	<p>If a scan tool is available:</p> <ul style="list-style-type: none"> • Check for proper communication with both the ECM. • Check the fuse in the ECM battery power circuit. Refer to Engine Controls Schematics. • Check battery power, ignition power and ground circuits to the ECM. Refer to Engine Control Schematics. Verify voltage and/or continuity for each circuit.
Sensor Checks	<ul style="list-style-type: none"> • Check the TMAP sensor. • Check the Magnetic pickup sensor (RPM).
Fuel System Checks	<p>Important: A closed LPG manual fuel shut off valve will create a no start condition.</p> <ul style="list-style-type: none"> • Check for air intake system leakage between the mixer and the throttle body. • Verify proper operation of the low pressure lock-off solenoids. • Check the fuel system pressures. Refer to the LPG Fuel System Diagnosis. • Check for proper mixer air valve operation.
Ignition System Checks	<p>Note: LPG being a gaseous fuel requires higher secondary ignition system voltages for the equivalent gasoline operating conditions.</p> <ul style="list-style-type: none"> • Check for the proper ignition voltage output with J 26792 or the equivalent. • Verify that the spark plugs are correct for use with LPG (R42LTS). • Check the spark plugs for the following conditions: <ul style="list-style-type: none"> - Wet plugs - Cracks - Wear - Improper gap - Burned electrodes - Heavy deposits • Check for bare or shorted ignition wires. • Check for loose ignition coil connections at the coil.
Engine Mechanical Checks	<p>Important: The LPG Fuel system works on a fumigation principle of fuel introduction and is more sensitive to intake manifold leakage than the gasoline fuel supply system.</p> <ul style="list-style-type: none"> • Check for the following: <ul style="list-style-type: none"> - Vacuum leaks - Improper valve timing - Low compression - Bent pushrods - Worn rocker arms - Broken or weak valve springs - Worn camshaft lobes

Table 3-16. Symptom Diagnosis

Checks	Action
Exhaust System Checks	<ul style="list-style-type: none"> • Check the exhaust system for a possible restriction: <ul style="list-style-type: none"> - Inspect the exhaust system for damaged or collapsed pipes - Inspect the muffler for signs of heat distress or for possible internal failure • Check for possible plugged catalytic converter. Refer to Restricted Exhaust System Diagnosis.
Hard Start	
DEFINITION: The engine cranks OK, but does not start for a long time. The engine does eventually run, or may start but immediately dies.	
Preliminary Checks	<ul style="list-style-type: none"> • Refer to Important Preliminary Checks. • Make sure the vehicle's operator is using the correct starting procedure.
Sensor Checks	<ul style="list-style-type: none"> • Check the Engine Coolant Temperature sensor with the scan tool. Compare the engine coolant temperature with the ambient air temperature on a cold engine. If the coolant temperature reading is more than 5 degrees greater or less than the ambient air temperature on a cold engine, check for high resistance in the coolant sensor circuit. Refer to DTC 111. • Check the Crankshaft Position (CKP) sensor. • Check the Throttle position (TPS) sensor.
Fuel System Checks	<p>Important: A closed LPG manual fuel shut off valve will create an extended crank OR no start condition.</p> <ul style="list-style-type: none"> • Verify the excess flow valve in the LPG manual shut-off valve is not tripped. • Check mixer module assembly for proper installation and leakage. • Verify proper operation of the low pressure lock-off solenoids. • Verify proper operation of the EPR. • Check for air intake system leakage between the mixer and the throttle body. • Check the fuel system pressures. Refer to the Fuel System Diagnosis.
Ignition System Checks	<p>Note: LPG being a gaseous fuel requires higher secondary ignition system voltages for the equivalent gasoline operating conditions.</p> <ul style="list-style-type: none"> • Check for the proper ignition voltage output with J 26792 or the equivalent. • Verify that the spark plugs are correct for use with LPG (R42LTS). • Check the spark plugs for the following conditions: <ul style="list-style-type: none"> - Wet plugs - Cracks - Wear - Improper gap - Burned electrodes - Heavy deposits • Check for bare or shorted ignition wires. • Check for moisture in the distributor cap, if applicable. • Check for loose ignition coil connections. <p>Important:</p> <ol style="list-style-type: none"> 1. If the engine starts but then immediately stalls, Check the Crankshaft Position (CKP). 2. Check for improper gap, debris or faulty connections.
Engine Mechanical Checks	<p>Important: The LPG Fuel system works on a fumigation principle of fuel introduction and is more sensitive to intake manifold leakage than the gasoline fuel supply system.</p> <ul style="list-style-type: none"> • Check for the following: <ul style="list-style-type: none"> - Vacuum leaks - Improper valve timing - Low compression - Bent pushrods - Worn rocker arms - Broken or weak valve springs - Worn camshaft lobes • Check the intake and exhaust manifolds for casting flash.

SECTION 3 - CHASSIS, PLATFORM & SCISSOR ARMS

Table 3-16. Symptom Diagnosis

Checks	Action
Exhaust System Checks	<ul style="list-style-type: none"> • Check the exhaust system for a possible restriction: <ul style="list-style-type: none"> - Inspect the exhaust system for damaged or collapsed pipes - Inspect the muffler for signs of heat distress or for possible internal failure • Check for possible plugged catalytic converter. Refer to Restricted Exhaust System Diagnosis or Exhaust System in the GM Base Engine Service Manual.
Cuts Out, Misses	
<p>DEFINITION: A surging or jerking that follows engine speed, usually more pronounced as the engine load increases which is not normally felt above 1500 RPM. The exhaust has a steady spitting sound at idle, low speed, or hard acceleration for the fuel starvation that can cause the engine to cut-out.</p>	
Preliminary Checks	<ul style="list-style-type: none"> • Refer to Important Preliminary Checks.
Ignition System Checks	<ul style="list-style-type: none"> • Start the engine. • Wet down the secondary ignition system with water from a spray bottle, and look/listen for arcing or misfiring as you apply water. • Check for proper ignition output voltage with spark tester J 26792. • Check for a cylinder misfire. • Verify that the spark plugs are correct for use with LPG (R42LTS). • Remove the spark plugs in these cylinders and check for the following conditions: <ul style="list-style-type: none"> - Insulation cracks - Wear - Improper gap - Burned electrodes - Heavy deposits • Visually/Physically inspect the secondary ignition for the following: <ul style="list-style-type: none"> - Ignition wires for arcing, cross-firing and proper routing - Ignition coils for cracks or carbon tracking
Engine Mechanical Checks	<ul style="list-style-type: none"> • Perform a cylinder compression check. • Check the engine for the following: <ul style="list-style-type: none"> - Improper valve timing - Bent pushrods¹¹⁰ - Worn rocker arms - Worn camshaft lobes - Broken or weak valve springs • Check the intake and exhaust manifold passages for casting flash.
Fuel System Checks	<ul style="list-style-type: none"> • Check the fuel system - plugged fuel filter, low fuel pressure, etc. Refer to LPG Fuel System Diagnosis. • Check the condition of the wiring to the low pressure lock-off solenoid.
Additional Check	<p>Check for Electromagnetic Interference (EMI).</p> <ul style="list-style-type: none"> • EMI on the reference circuit can cause a missing condition. • Monitoring the engine RPM with a scan tool can detect an EMI. • A sudden increase in the RPM with little change in the actual engine RPM, indicates EMI is present. • If the problem exists, check the routing of the secondary wires and the ground circuit.

Table 3-16. Symptom Diagnosis

Checks	Action
Hesitation, Sag, Stumble	
DEFINITION: The vehicle has a momentary lack of response when depressing the accelerator. The condition can occur at any vehicle speed. The condition may cause the engine to stall if it's severe enough.	
Preliminary Checks	Refer to Important Preliminary Checks.
Fuel System Checks	<ul style="list-style-type: none"> • Check the fuel pressure. Refer to LPG Fuel System Diagnosis. • Check for low fuel pressure during a moderate or full throttle acceleration. If the fuel pressure drops below specification, there is possibly a faulty low pressure regulator or a restriction in the fuel system. • Check the Manifold Absolute Pressure (MAP) sensor response and accuracy. • Check LPL electrical connection. • Check the mixer air valve for sticking or binding. • Check the mixer module assembly for proper installation and leakage. • Check the EPR electrical connections.
Ignition System Checks	<p>Note: LPG being a gaseous fuel requires higher secondary ignition system voltages for the equivalent gasoline operating conditions. If a problem is reported on LPG and not gasoline, do not discount the possibility of a LPG only ignition system failure and test the system accordingly.</p> <ul style="list-style-type: none"> • Check for the proper ignition voltage output with J 26792 or the equivalent. • Verify that the spark plugs are correct for use with LPG (R42LTS). • Check for faulty spark plug wires. • Check for fouled spark plugs.
Additional Check	<ul style="list-style-type: none"> • Check for manifold vacuum or air induction system leaks. • Check the generator output voltage.
Backfire	
DEFINITION: The fuel ignites in the intake manifold, or in the exhaust system, making a loud popping noise.	
Preliminary Check	<ul style="list-style-type: none"> • Refer to Important Preliminary Checks.
Ignition System Checks	<p>Important: LPG, being a gaseous fuel, requires higher secondary ignition system voltages for the equivalent gasoline operating conditions. The ignition system must be maintained in peak condition to prevent backfire.</p> <ul style="list-style-type: none"> • Check for the proper ignition coil output voltage using the spark tester J26792 or the equivalent. • Check the spark plug wires by connecting an ohmmeter to the ends of each wire in question. If the meter reads over 30,000 ohms, replace the wires. • Check the connection at each ignition coil. • Check for deteriorated spark plug wire insulation. • Check the spark plugs. The correct spark plugs for LPG are (R42LTS). • Remove the plugs and inspect them for the following conditions: <ul style="list-style-type: none"> - Wet plugs - Cracks - Wear - Improper gap - Burned electrodes - Heavy deposits
Engine Mechanical Check	<p>Important: The LPG Fuel system works on a fumigation principle of fuel introduction and is more sensitive to intake manifold leakage than a gasoline fuel supply system.</p> <ul style="list-style-type: none"> • Check the engine for the following: <ul style="list-style-type: none"> - Improper valve timing - Engine compression - Manifold vacuum leaks - Intake manifold gaskets - Sticking or leaking valves - Exhaust system leakage • Check the intake and exhaust system for casting flash or other restrictions.
Fuel System Checks	<ul style="list-style-type: none"> • Perform a fuel system diagnosis. Refer to LPG Fuel System Diagnosis.

SECTION 3 - CHASSIS, PLATFORM & SCISSOR ARMS

Table 3-16. Symptom Diagnosis

Checks	Action
Lack of Power, Sluggishness, or Sponginess	
DEFINITION: The engine delivers less than expected power. There is little or no increase in speed when partially applying the accelerator pedal.	
Preliminary Checks	<ul style="list-style-type: none"> • Refer to Important Preliminary Checks. • Refer to the LPG Fuel system OBD System Check. • Compare the customer's vehicle with a similar unit. Make sure the customer has an actual problem. Do not compare the power output of the vehicle operating on LPG to a vehicle operating on gasoline as the fuels do have different drive feel characteristics. • Remove the air filter and check for dirt or restriction. • Check the vehicle transmission Refer to the OEM transmission diagnostics.
Fuel System Checks	<ul style="list-style-type: none"> • Check for a restricted fuel filter, contaminated fuel, or improper fuel pressure. Refer to LPG Fuel System Diagnosis. • Check for the proper ignition output voltage with the spark tester J 26792 or the equivalent. • Check for proper installation of the mixer module assembly. • Check all air inlet ducts for condition and proper installation. • Check for fuel leaks between the LPR and the mixer. • Verify that the LPG tank manual shut-off valve is fully open. • Verify that liquid fuel (not vapor) is being delivered to the LPR.
Sensor Checks	<ul style="list-style-type: none"> • Check the Heated Exhaust Gas Oxygen Sensor (HEGO) for contamination and performance. Check for proper operation of the MAP sensor. • Check for proper operation of the TPS sensor.
Exhaust System Checks	<ul style="list-style-type: none"> • Check the exhaust system for a possible restriction: <ul style="list-style-type: none"> - Inspect the exhaust system for damaged or collapsed pipes - Inspect the muffler for signs of heat distress or for possible internal failure - Check for possible plugged catalytic converter
Engine Mechanical Check	<ul style="list-style-type: none"> • Check the engine for the following: <ul style="list-style-type: none"> - Engine compression - Valve timing - Improper or worn camshaft. Refer to Engine Mechanical in the Service Manual
Additional Check	<ul style="list-style-type: none"> • Check the ECM grounds for being clean, tight, and in their proper locations. • Check the generator output voltage. • If all procedures have been completed and no malfunction has been found, review and inspect the following items: <ul style="list-style-type: none"> - Visually and physically, inspect all electrical connections within the suspected circuit and/or systems - Check the scan tool data
Poor Fuel Economy	
DEFINITION: Fuel economy, as measured by refueling records, is noticeably lower than expected. Also, the economy is noticeably lower than it was on this vehicle at one time, as previously shown by refueling records.	
Preliminary Checks	<ul style="list-style-type: none"> • Refer to Important Preliminary Checks. • Check the air cleaner element (filter) for dirt or being plugged. • Visually (Physically) check the vacuum hoses for splits, kinks, and proper connections. • Check the operator's driving habits for the following items: <ul style="list-style-type: none"> - Is there excessive idling or stop and go driving? - Are the tires at the correct air pressure? - Are excessively heavy loads being carried? - Is their often rapid acceleration? • Suggest to the owner to fill the fuel tank and to recheck the fuel economy. • Suggest that a different operator use the equipment and record the results.
Fuel System Checks	<ul style="list-style-type: none"> • Check the LPR fuel pressure. Refer to LPG Fuel System Diagnosis. • Check the fuel system for leakage.
Sensor Checks	<ul style="list-style-type: none"> • Check the Temperature Manifold Absolute Pressure (TMAP) sensor.

Table 3-16. Symptom Diagnosis

Checks	Action
Ignition System Checks	<ul style="list-style-type: none"> • Verify that the spark plugs are correct for use with LPG (R42LTS). • Check the spark plugs. Remove the plugs and inspect them for the following conditions: <ul style="list-style-type: none"> - Wet plugs - Cracks - Wear - Improper gap - Burned electrodes - Heavy deposits • Check the ignition wires for the following items: <ul style="list-style-type: none"> - Cracking - Hardness - Proper connections
Cooling System Checks	<ul style="list-style-type: none"> • Check the engine thermostat for always being open or for the wrong heat range.
Additional Check	<ul style="list-style-type: none"> • Check the transmission shift pattern. Refer to the OEM Transmission Controls section the Service Manual. • Check for dragging brakes.
Rough, Unstable, or Incorrect Idle, Stalling	
<p>DEFINITION: The engine runs unevenly at idle. If severe enough, the engine or vehicle may shake. The engine idle speed may vary in RPM. Either condition may be severe enough to stall the engine.</p>	
Preliminary Check	Refer to Important Preliminary Checks.
Sensor Checks	<ul style="list-style-type: none"> • Check for silicon contamination from fuel or improperly used sealant. The sensor will have a white powdery coating. The sensor will result in a high but false signal voltage (rich exhaust indication). The ECM will reduce the amount of fuel delivered to the engine causing a severe driveability problem. • Check the Heated Exhaust Gas Oxygen Sensor (HEGO) performance. • Check the Temperature Manifold Absolute Pressure (TMAP) sensor response and accuracy.
Fuel System Checks	<ul style="list-style-type: none"> • Check for rich or lean symptom that causes the condition. Drive the vehicle at the speed of the complaint. Monitoring the oxygen sensors will help identify the problem. • Check for a sticking mixer air valve. • Verify proper operation of the EPR. • Perform a cylinder compression test. Refer to Engine Mechanical in the Service Manual. • Check the LPR fuel pressure. Refer to the LPG Fuel System Diagnosis. • Check mixer module assembly for proper installation and connection.
Ignition System Checks	<ul style="list-style-type: none"> • Check for the proper ignition output voltage using the spark tester J26792 or the equivalent. • Verify that the spark plugs are correct for use with LPG (R42LTS). • Check the spark plugs. Remove the plugs and inspect them for the following conditions: <ul style="list-style-type: none"> - Wet plugs - Cracks - Wear - Improper gap - Burned electrodes - Blistered insulators - Heavy deposits • Check the spark plug wires by connecting an ohmmeter to the ends of each wire in question. If the meter reads over 30,000 ohms, replace the wires.
Additional Checks	<p>Important: The LPG Fuel system works on a fumigation principle of fuel introduction and is more sensitive to intake manifold leakage than the gasoline fuel supply system.</p> <ul style="list-style-type: none"> • Check for vacuum leaks. Vacuum leaks can cause a higher than normal idle and low throttle angle control command. • Check the ECM grounds for being clean, tight, and in their proper locations. • Check the battery cables and ground straps. They should be clean and secure. Erratic voltage may cause all sensor readings to be skewed resulting in poor idle quality.

SECTION 3 - CHASSIS, PLATFORM & SCISSOR ARMS

Table 3-16. Symptom Diagnosis

Checks	Action
Engine Mechanical Check	<ul style="list-style-type: none"> • Check the engine for the following: <ul style="list-style-type: none"> - Broken motor mounts - Improper valve timing - Low compression - Bent pushrods - Worn rocker arms - Broken or weak valve springs - Worn camshaft lobes
Surges/Chuggles	
DEFINITION: The engine has a power variation under a steady throttle or cruise. The vehicle feels as if it speeds up and slows down with no change in the accelerator pedal.	
Preliminary Checks	Refer to Important Preliminary Checks.
Sensor Checks	<ul style="list-style-type: none"> • Check Heated Exhaust Gas Oxygen Sensor (HEGO) performance.
Fuel System Checks	<ul style="list-style-type: none"> • Check for Rich or Lean symptom that causes the condition. Drive the vehicle at the speed of the complaint. Monitoring the oxygen sensors will help identify the problem. • Check the fuel pressure while the condition exists. Refer to LPG Fuel System Diagnosis. • Verify proper fuel control solenoid operation. • Verify that the LPG manual shut-off valve is fully open. • Check the in-line fuel filter for restrictions.
Ignition System Checks	<ul style="list-style-type: none"> • Check for the proper ignition output voltage using the spark tester J26792 or the equivalent. • Verify that the spark plugs are correct for use with LPG (R42LTS). • Check the spark plugs. Remove the plugs and inspect them for the following conditions: <ul style="list-style-type: none"> - Wet plugs - Cracks - Wear - Improper gap - Burned electrodes - Heavy deposits • Check the Crankshaft Position (CKP) sensor
Additional Check	<ul style="list-style-type: none"> • Check the ECM grounds for being clean, tight, and in their proper locations. • Check the generator output voltage. • Check the vacuum hoses for kinks or leaks. • Check Transmission.

Table 3-17. DTC to SPN/FMI Cross Reference Chart

DTC	Description	SPN Code	FMI Code
16	Crank Never Synced at Start	636	8
91	Fuel Pump Low Voltage	94	4
92	Fuel Pump High Voltage	94	3
107	MAP Low Voltage	106	4
108	MAP High Pressure	106	16
111	IAT Higher Than Expected 1	105	15
112	IAT Low Voltage	105	4
113	IAT High Voltage	105	3
116	ECT Higher Than Expected 1	110	15
117	ECT Low Voltage	110	4
118	ECT High Voltage	110	3
121	TPS 1 Lower Than TPS 2	51	1
122	TPS 1 Signal Voltage Low	51	4
123	TPS 1 Signal Voltage High	51	3
127	IAT Higher Than Expected 2	105	0
129	BP Low Pressure	108	1
134	EGO 1 Open/Inactive	724	10
154	EGO 2 Open/Inactive	520208	10
171	Adaptive Learn High Gasoline	520200	0
172	Adaptive Learn Low Gasoline	520200	1
182	Fuel Temp Gasoline Low Voltage	174	4
183	Fuel Temp Gasoline High Voltage	174	3
187	Fuel Temp LPG Low Voltage	520240	4
188	Fuel Temp LPG High Voltage	520240	3
217	ECT Higher Than Expected 2	110	0
219	Max Govern Speed Override	515	15
221	TPS 2 Signal Voltage Low	51	0
222	TPS 2 Signal Low Voltage	520251	4
223	TPS 2 Signal High Voltage	520251	3
261	Injector Driver 1 Open	651	5
262	Injector Driver 1 Shorted	651	6
264	Injector Driver 2 Open	652	5
265	Injector Driver 2 Shorted	652	6
267	Injector Driver 3 Open	653	5
268	Injector Driver 3 Shorted	653	6
270	Injector Driver 4 Open	654	5
271	Injector Driver 4 Shorted	654	6
336	Crank Sync Noise	636	2
337	Crank Loss	636	4
341	Cam Sync Noise	723	2
342	Cam Sensor Loss	723	4
420	Gasoline Cat Monitor	520211	10
524	Oil Pressure Low	100	1

SECTION 3 - CHASSIS, PLATFORM & SCISSOR ARMS

Table 3-17. DTC to SPN/FMI Cross Reference Chart

DTC	Description	SPN Code	FMI Code
562	System Voltage Low	168	17
563	System Voltage High	168	15
601	Flash Checksum Invalid	628	13
604	RAM Failure	630	12
606	COP Failure	629	31
642	External 5V Reference Low	1079	4
643	External 5V Reference High	1079	3
685	Power Relay Open	1485	5
686	Power Relay Shorted	1485	4
687	Power Relay Short to Power	1485	3
1111	Fuel Rev Limit	515	16
1112	Spark Rev Limit	515	0
1151	Closed Loop Multiplier High LPG	520206	0
1152	Closed Loop Multiplier Low LPG	520206	1
1155	Closed Loop Multiplier High Gasoline	520204	0
1156	Closed Loop Multiplier Low Gasoline	520204	1
1161	Adaptive Learn High LPG	520202	0
1162	Adaptive Learn Low LPG	520202	1
1165	LPG Cat Monitor	520213	10
1171	LPG Pressure Higher Than Expected	520260	0
1172	LPG Pressure Lower Than Expected	520260	1
1173	EPR Comm Lost	520260	31
1174	EPR Voltage Supply High	520260	3
1175	EPR Voltage Supply Low	520260	4
1176	EPR Internal Actuator Fault	520260	12
1177	EPR Internal Circuitry Fault	520260	12
1178	EPR Internal Comm Fault	520260	12
1612	RTI 1 loss	629	31
1613	RTI 2 Loss	629	31
1614	RTI 3 Loss	629	31
1615	A/D Loss	629	31
1616	Invalid Interrupt	629	31
1625	Shutdown Request	1384	31
1626	CAN Tx Failure	639	12
1627	CAN Rx Failure	639	12
1628	CAN Address Conflict Failure	639	13
1629	Loss of TSC 1	639	31
2111	Unable to Reach Lower TPS	51	7
2112	Unable to Reach Higher TPS	51	
2135	TPS 1/2 Simultaneous Voltages	51	31
2229	BP Pressure High	108	0

SECTION 4. HYDRAULICS

4.1 CYLINDERS - THEORY OF OPERATION

Cylinders are of the double acting type. The steer system incorporates a double acting cylinder. A double acting cylinder is one that requires oil flow to operate the cylinder rod in both directions. Directing oil (by actuating the corresponding control valve to the piston side of the cylinder) forces the piston to travel toward the rod end of the barrel, extending the cylinder rod (piston attached to rod). When the oil flow is stopped, movement of the rod will stop. By directing oil to the rod side of the cylinder, the piston will be forced in the opposite direction and the cylinder rod will retract.

NOTE: *The lift cylinder is a single acting cylinder which takes hydraulic pressure to extend and gravity to retract.*

A holding valve is used in the lift circuit to prevent retraction of the cylinder rod should a hydraulic line rupture or a leak develop between the cylinder and its related control valve.

4.2 VALVES - THEORY OF OPERATION

Solenoid Control Valves (Bang-Bang)

Control valves used are four-way three-position solenoid valves of the sliding spool design. When a circuit is activated and the control valve solenoid energizes, the spool is shifted and the corresponding work port opens to permit oil flow to the component in the selected circuit, with the opposite work port opening to reservoir. Once the circuit is deactivated (control returned to neutral), the valve spool returns to neutral (center) and oil flow is then directed through the valve body and returns to reservoir. A typical control valve consists of the valve body, sliding spool, and two solenoid assemblies. The spool is machine fitted in the bore of the valve body. Lands on the spool divide the bore into various chambers, which, when the spool is shifted, align with corresponding ports in the valve body open to common flow. At the same time other ports would be blocked to flow. The spool is spring-loaded to center position, therefore when the control is released, the spool automatically returns to neutral, prohibiting any flow through the circuit.

Relief Valves

Main relief valves are installed at various points within the hydraulic system to protect associated systems and components against excessive pressure. Excessive pressure can be developed when a cylinder reaches its limit of travel and the flow of pressurized fluid continues from the system control. The relief valve provides an alternate path for the continuing flow from the pump, thus preventing

rupture of the cylinder, hydraulic line or fitting. Complete failure of the system pump is also avoided by relieving circuit pressure. The relief valve is installed in the circuit between the pump outlet (pressure line) and the cylinder of the circuit, generally as an integral part of the system valve bank. Relief pressures are set slightly higher than the load requirement, with the valve diverting excess pump delivery back to the reservoir when operating pressure of the component is reached.

Crossover Relief Valves

Crossover relief valves are used in circuits where the actuator requires an operating pressure lower than that supplied to the system. When the circuit is activated and the required pressure at the actuator is developed, the crossover relief diverts excess pump flow to the reservoir. Individual, integral relief's are provided for each side of the circuit.

4.3 CYLINDER CHECKING PROCEDURE

NOTE: *Cylinder check must be performed anytime a system component is replaced or when improper system operation is suspected.*

Cylinders Without Counterbalance Valves

1. Using all applicable safety precautions, activate engine and fully extend cylinder to be checked. Shut down engine.
2. Carefully disconnect hydraulic hoses from retract port of cylinder. There will be some initial weeping of hydraulic fluid which can be caught in a suitable container. After the initial discharge, there should be no further drainage from the retract port.
3. Activate engine and extend cylinder.
4. If cylinder retract port leakage is less than 6-8 drops per minute, carefully reconnect hose to port and retract cylinder. If leakage continues at a rate of 6-8 drops per minute or more, cylinder repair must be made.
5. With cylinder fully retracted, shut down engine and carefully disconnect hydraulic hose from cylinder extend port.
6. Activate engine and retract cylinder. Check extend port for leakage.
7. If extend port leakage is less than 6-8 drops per minute, carefully reconnect hose to extend port, then activate cylinder through one complete cycle and check for leaks. If leakage continues at a rate of 6-8 drops per minute or more, cylinder repairs must be made.

Cylinders With Single Counterbalance Valve

NOTICE

OPERATE ALL FUNCTIONS FROM GROUND CONTROL STATION ONLY.

1. Using all applicable safety precautions, activate hydraulic system.
2. Shut down hydraulic system and allow machine to sit for 10-15 minutes. If machine is equipped with bang-bang or proportional control valves, turn ignition switch to on, move control switch or lever for applicable cylinder in each direction, then turn ignition switch to off. If machine is equipped with hydraulic control valves, move control lever for applicable cylinder in each direction. This is done to relieve pressure in the hydraulic lines. Carefully remove hydraulic hoses from appropriate cylinder port block.
3. There will be initial weeping of hydraulic fluid, which can be caught in a suitable container. After the initial discharge, there should be no further leakage from the ports. If leakage continues at a rate of 6-8 drops per minute or more, the counterbalance valve is defective and must be replaced.
4. To check piston seals, carefully remove the counterbalance valve from the retract port. After initial discharge, there should be no further leakage from the ports. If leakage occurs at a rate of 6-8 drops per minute or more, the piston seals are defective and must be replaced.
5. If no repairs are necessary or when repairs have been made, replace counterbalance valve and carefully connect hydraulic hoses to cylinder port block.
6. If used, remove lifting device from upright or remove prop from below main boom, activate hydraulic system and run cylinder through one complete cycle to check for leaks.

Oscillating Axle Cylinder Test (Lockout)

NOTICE

LOCKOUT SYSTEM TEST MUST BE PERFORMED QUARTERLY, ANY TIME A SYSTEM COMPONENT IS REPLACED, OR WHEN IMPROPER SYSTEM OPERATION IS SUSPECTED.

NOTE: Ensure platform is fully lowered prior to beginning lockout cylinder test.

1. Place a 6 inch (15.2 cm) high block with ascension ramp in front of left front wheel.
2. From platform control station, select LOW drive speed.
3. Place DRIVE control switch to FORWARD position and carefully drive the machine up ascension ramp until left front wheel is on top of block.
4. Raise machine platform approximately 9 ft (2.7 m) on the 3394RT or 10 ft (3.1 m) on the 4394RT.
5. Place DRIVE control switch to REVERSE position and carefully drive the machine off the block and ramp.
6. Have an assistant check to see that the left front wheel remains locked in position off the ground.
7. Lower the machine platform; the lockout cylinder should then release and allow wheel to rest on the ground. It may be necessary to activate DRIVE to release cylinders.
8. Place the 6 inch (15.2 cm) high block with ascension ramp in front of right front wheel.
9. From platform control station, select LOW drive speed.
10. Place DRIVE control switch to FORWARD position and carefully drive the machine up ascension ramp until right front wheel is on top of block.
11. Raise machine platform approximately 9 ft (2.7 m) on the 3394RT or 10 ft (3.1 m) on the 4394RT.
12. Place DRIVE control switch to REVERSE position and carefully drive the machine off the block and ramp.
13. Have an assistant check to see that the right front wheel remains locked in position off the ground.
14. Lower the machine platform; the lockout cylinder should then release and allow wheel to rest on the ground. It may be necessary to activate DRIVE to release cylinders.
15. If the lockout cylinders do not function properly, have qualified personnel correct the malfunction prior to any further operation.

4.4 CYLINDER REPAIR

NOTE: The following are general procedures that apply to all cylinders on this machine. Procedures that apply to a specific cylinder will be so noted.

Disassembly

NOTICE

DISASSEMBLY OF THE CYLINDER SHOULD BE PERFORMED ON A CLEAN WORK SURFACE IN A DIRT FREE WORK AREA.

1. Connect a suitable auxiliary hydraulic power source to the cylinder port block fitting.

WARNING

DO NOT FULLY EXTEND CYLINDER TO THE END OF STROKE. RETRACT CYLINDER SLIGHTLY TO AVOID TRAPPING PRESSURE.

2. Operate the hydraulic power source and extend the cylinder. Shut down and disconnect the power source. Adequately support the cylinder rod, if applicable.
3. If applicable, remove the cartridge-type holding valve and fittings from the cylinder port block. Discard o-rings.

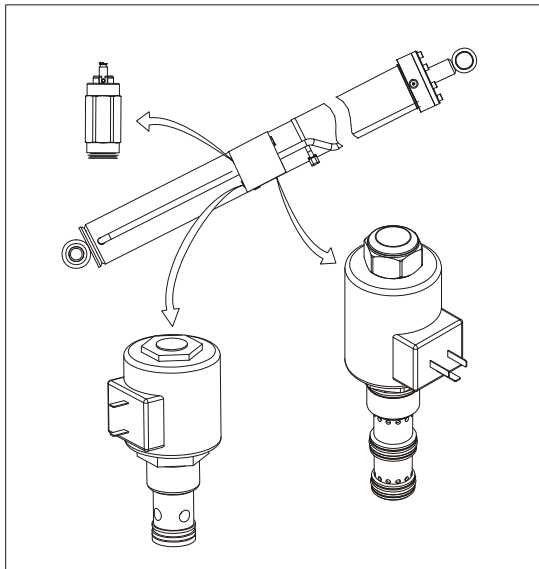

Figure 4-1. Lift Cylinder Holding Valve and Fitting Removal

4. Place the cylinder barrel into a suitable holding fixture.

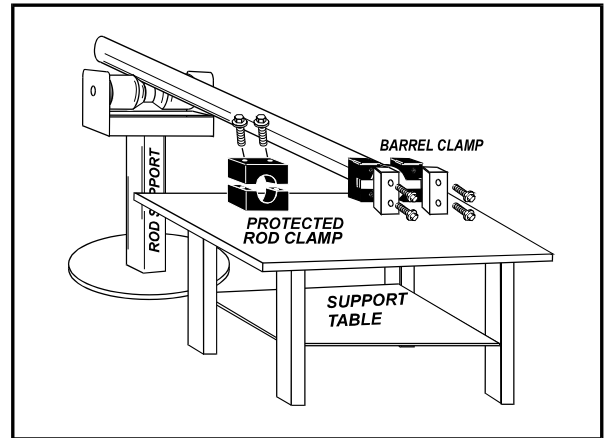

Figure 4-2. Cylinder Barrel Support

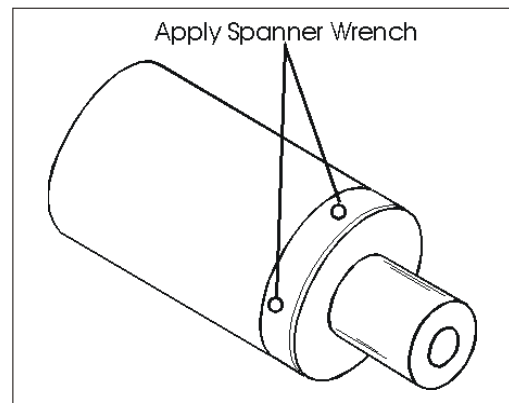
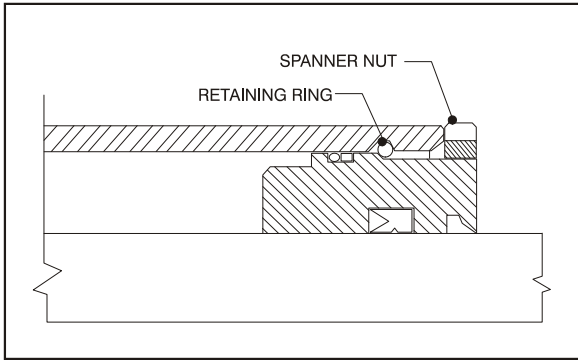

Figure 4-3. Lift Cylinder Cap Screw Removal

NOTE: Steps 6 and 7 apply only to the steer cylinder.

5. Using a spanner wrench, loosen the spanner nut retainer, and remove spanner nut from cylinder barrel.
6. Being careful not to mar the surface of the rod, use a punch or wooden dowel and hammer to drive the rod guide about one inch down into the cylinder bore. Using a screw driver, carefully push one end of the round retaining ring back towards the inside of the cylinder and then slip the screwdriver tip under that end. Pull the ring out of the groove toward the wall mouth. Once one end of the retaining ring is free from the groove, the remainder can be easily pried free using ones fingers or pliers.



- Attach a suitable pulling device to the cylinder rod port block end or cylinder rod end, as applicable.

NOTICE

EXTREME CARE SHOULD BE TAKEN WHEN REMOVING THE CYLINDER ROD, HEAD, AND PISTON. AVOID PULLING THE ROD OFF-CENTER, WHICH COULD CAUSE DAMAGE TO THE PISTON AND CYLINDER BARREL SURFACES.

- With the barrel securely clamped, apply pressure to the rod pulling device and carefully withdraw the complete rod assembly from the cylinder barrel.

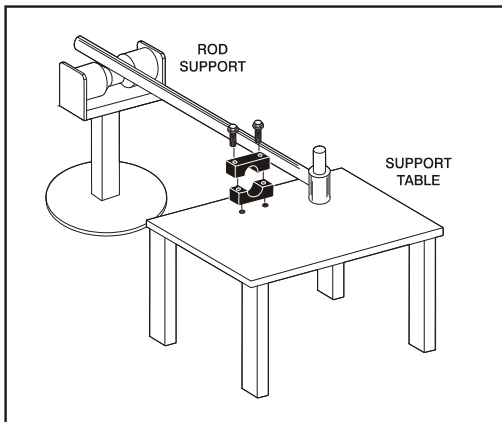

Figure 4-4. Cylinder Rod Support

- Using suitable protection, clamp the cylinder rod in a vise or similar holding fixture as close to the piston as possible.

NOTE: Step 11 applies only to the steer cylinder.

- Loosen and remove the nut which attaches the piston to the rod, and remove the piston.
- Loosen and remove the cap screw(s), if applicable, which attach the tapered bushing to the piston.
- Insert the cap screw(s) in the threaded holes in the outer piece of the tapered bushing. Progressively

tighten the cap screw(s) until the bushing is loose on the piston.

- Remove the bushing from the piston.

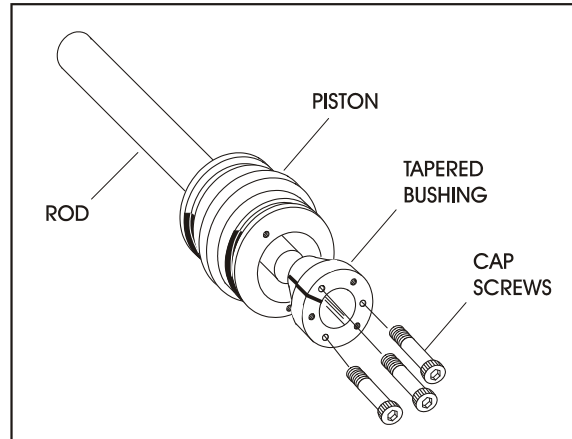

Figure 4-5. Tapered Bushing Removal

- Screw the piston counter-clockwise, by hand, and remove the piston from cylinder rod.
- Remove and discard the piston o-rings, seal rings, and backup rings.
- Remove piston spacer, if applicable, from the rod.
- Remove the rod from the holding fixture. Remove the cylinder head gland and retainer plate, if applicable. Discard the o-rings, back-up rings, rod seals, and wiper seals.

Cleaning and Inspection

- Clean all parts thoroughly in an approved cleaning solvent.
- Inspect the cylinder rod for scoring, tapering, ovality, or other damage. If necessary, dress rod with Scotch Brite or equivalent. Replace rod if necessary.
- Inspect threaded portion of rod for excessive damage. Dress threads as necessary.
- Inspect inner surface of cylinder barrel tube for scoring or other damage. Check inside diameter for tapering or ovality. Replace if necessary.
- Inspect threaded portion of barrel for damage. Dress threads as necessary.
- Inspect piston surface for damage and scoring and for distortion. Dress piston surface or replace piston as necessary.
- Inspect threaded portion of piston for damage. Dress threads as necessary.

8. Inspect seal and o-ring grooves in piston for burrs and sharp edges. Dress applicable surfaces as necessary.
9. Inspect cylinder head inside diameter for scoring or other damage and for ovality and tapering. Replace as necessary.
10. Inspect threaded portion of head for damage. Dress threads as necessary.
11. Inspect seal and o-ring grooves in head for burrs and sharp edges. Dress applicable surfaces as necessary.
12. Inspect cylinder head outside diameter for scoring or other damage and ovality and tapering. Replace as necessary.
13. If applicable, inspect rod and barrel bearings for signs of correct excessive wear or damage. Replace as necessary.
 - a. Thoroughly clean hole, (steel bushing) of burrs, dirt etc. to facilitate bearing installation.
 - b. Inspect steel bushing for wear or other damage. If steel bushing is worn or damaged, rod/barrel must be replaced.
 - c. Lubricate inside of steel bushing with WD40 prior to bearing installation.
 - d. Using an arbor of the correct size, carefully press the bearing into steel bushing.

NOTE: Install pin into the Gar-Max bearing dry. Lubrication is not required with nickel plated pins and bearings.

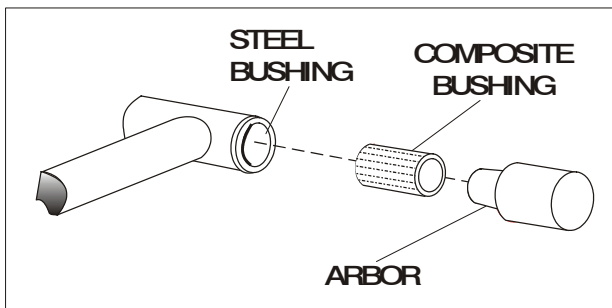

Figure 4-6. Bushing Installation

14. Inspect travel limiting collar or spacer for burrs and sharp edges. If necessary, dress inside diameter surface with Scotch Brite or equivalent.
15. If applicable, inspect port block fittings and holding valve. Replace as necessary.
16. Inspect the oil ports for blockage or the presence of dirt or other foreign material. Repair as necessary.
17. If applicable, inspect piston rings for cracks or other damage. Replace as necessary.

Assembly

NOTE: Prior to cylinder assembly, ensure that the proper cylinder seal kit is used. See your JLG Parts Manual.

Apply a light film of hydraulic oil to all components prior to assembly.

1. A special tool is used to install a new rod seal into the applicable cylinder head gland groove.

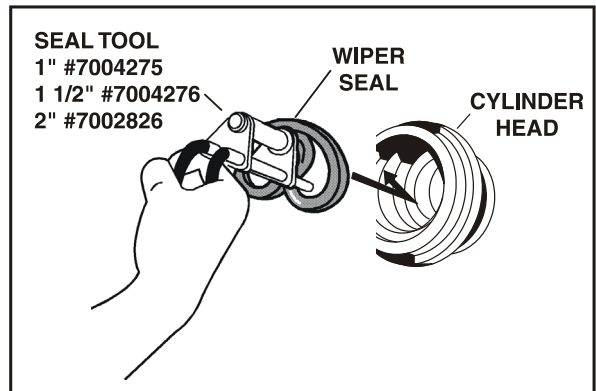

Figure 4-7. Rod Seal Installation

NOTICE

WHEN INSTALLING 'POLY-PAK' PISTON SEALS, ENSURE SEALS ARE INSTALLED PROPERLY. REFER TO WIPER SEAL INSTALLATION FOR CORRECT SEAL ORIENTATION. IMPROPER SEAL INSTALLATION COULD RESULT IN CYLINDER LEAKAGE AND IMPROPER CYLINDER OPERATION.

WHEN INSTALLING THE WIPER SEAL ON THE LOWER (TOWER) LIFT CYLINDER, APPLY LOCTITE® #609 ON THE WIPER SEAL IN THREE EVENLY SPACED PLACES TO AID IN RETENTION OF THE SEAL.

2. Use a soft mallet to tap a new wiper seal into the applicable cylinder head gland groove. Install a new wear ring into the applicable cylinder head gland-groove.

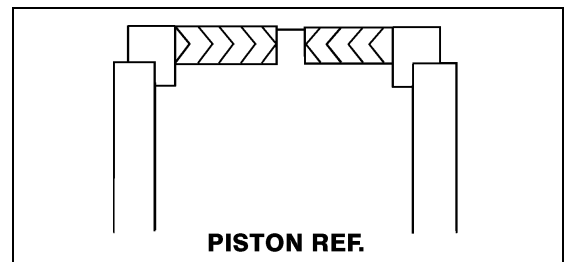

Figure 4-8. Poly-Pak Piston Seal Installation

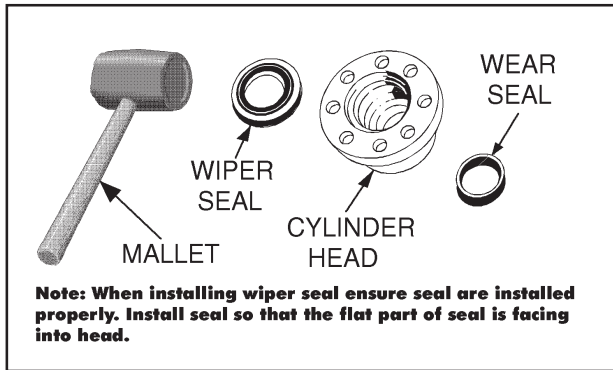

Figure 4-9. Wiper Seal Installation

- Place a new "o"ring and back-up seal in the applicable outside diameter groove of the cylinder head.

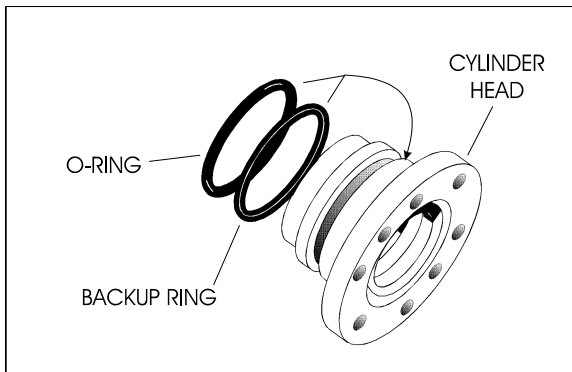

Figure 4-10. Installation of Head Seal Kit

- Install washer ring onto rod. Carefully install the head gland on the rod, ensuring that the wiper and rod seals are not damaged or dislodged. Push the head along the rod to the rod end, as applicable.
- Carefully slide the piston spacer on the rod.
- If applicable, correctly place new o-ring in the inner piston diameter groove. (The backup ring side facing the O-ring is grooved.)
- If applicable, correctly place new seals and guide lock rings in the outer piston diameter groove. (A tube, with I.D. slightly larger than the O.D. of the piston is recommended to install the solid seal.)

NOTE: The backup rings for the solid seal have a radius on one side. This side faces the solid seal. [See magnified insert in (See Figure 4-11.)] The split of seals and backup rings must be positioned so as not to be in alignment with each other.

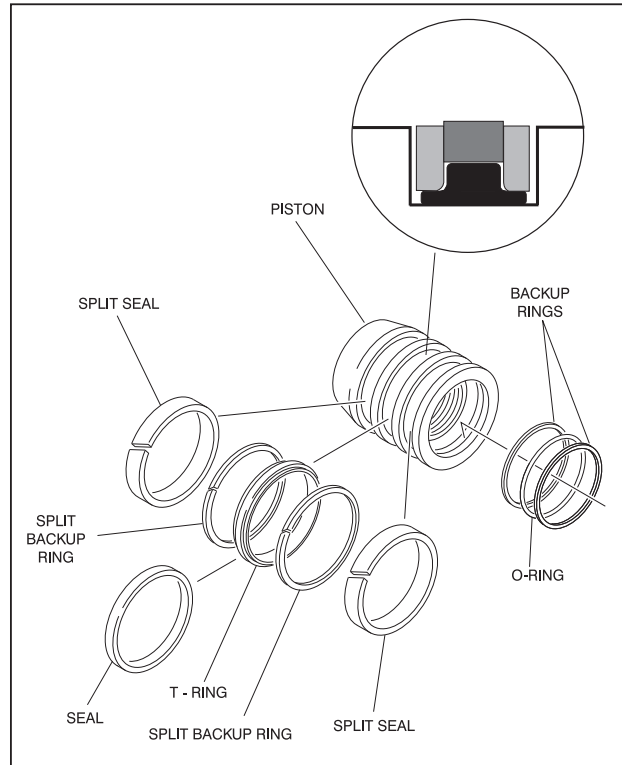

Figure 4-11. Piston Seal Kit Installation

- Using suitable protection, clamp the cylinder rod in a vise or similar holding fixture as close to piston as possible.
- Carefully thread the piston on the cylinder rod hand tight, ensuring that the o-ring and back-up rings are not damaged or dislodged.
- Thread piston onto rod until it abuts the spacer end and install the tapered bushing.

NOTE: When installing the tapered bushing, piston and mating end of rod must be free of oil.

- Assemble the tapered bushing loosely into the piston and insert JLG capscrews (not vendor capscrews) through the drilled holes in the bushing and into the tapped holes in the piston.

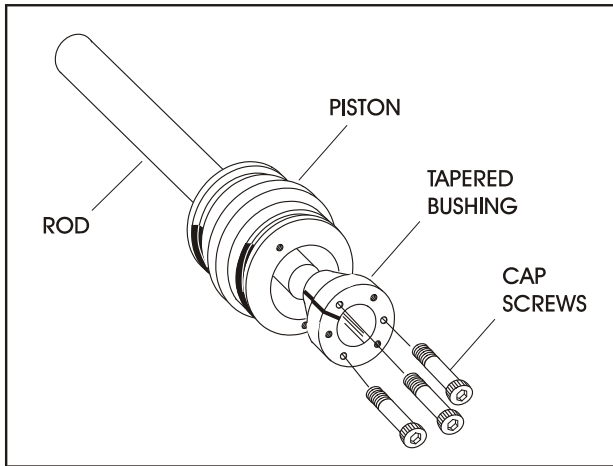

Figure 4-12. Tapered Bushing Installation

12. Tighten the capscrews evenly and progressively in rotation to the specified torque value.
13. After the screws have been torqued, tap the tapered bushing with a hammer (16 to 24 oz.) and brass shaft (approximately 3/4" in diameter) as follows;
 - a. Place the shaft against the cylinder rod and in contact with the bushing in the spaces between the capscrews.
 - b. Tap each space once; this means the tapered bushing is tapped 3 times as there are 3 spaces between the capscrews.

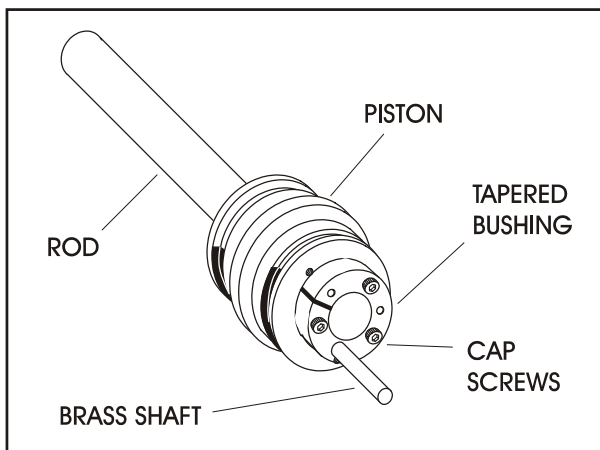

Figure 4-13. Seating the Tapered Bearing

14. Re-torque the capscrews evenly and progressively in rotation to the specified torque value.
15. Remove the cylinder rod from the holding fixture.
16. Place new guide locks and seals in the applicable outside diameter grooves of the cylinder piston. (See Figure 4-11.)

17. Position the cylinder barrel in a suitable holding fixture.

NOTICE

EXTREME CARE SHOULD BE TAKEN WHEN INSTALLING THE CYLINDER ROD, HEAD, AND PISTON. AVOID PULLING THE ROD OFF-CENTER, WHICH COULD CAUSE DAMAGE TO THE PISTON AND CYLINDER BARREL SURFACES.

18. With barrel clamped securely, and while adequately supporting the rod, insert the piston end into the barrel cylinder. Ensure that the piston loading o-ring and seal ring are not damaged or dislodged.
19. Continue pushing the rod into the barrel until the cylinder head gland can be inserted into the barrel cylinder.
20. Secure the cylinder head gland using the washer ring and socket head bolts.

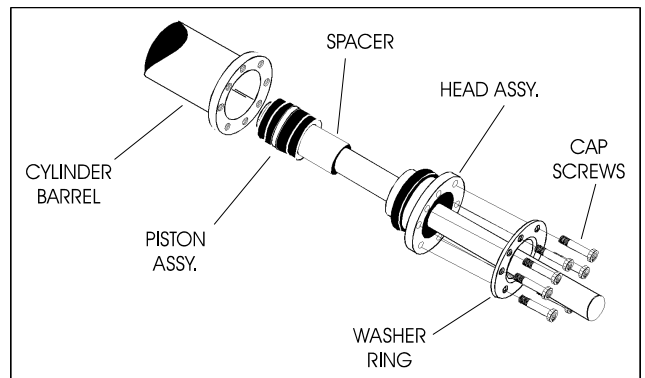

Figure 4-14. Rod Assembly Installation

21. After the cylinder has been reassembled, the rod should be pushed all the way in (fully retracted) prior to the reinstallation of any holding valve or valves.
22. If applicable, install the cartridge-type holding valve and fittings in the rod port block, using new o-rings as applicable. (See Table 4-2, Holding Valve Torque Specifications).
23. Push the piston onto the rod until it abuts the spacer end and install the attaching nut.

WARNING

WHEN REBUILDING THE CYLINDERS, APPLY LOCTITE® #242 TO PISTON NUT AND SETSCREW, THEN TORQUE PISTON NUT. REFER TO TABLE 4-1, CYLINDER PISTON NUT TORQUE SPECIFICATIONS.

NOTE: The Steer Cylinder uses snap rings to secure piston.

Table 4-1. Cylinder Piston Nut Torque Specifications

Description	Nut Torque Value	Setscrew torque Value
Lift Cylinder	400 lb-ft (542 Nm)	100 in.lbs. (12 Nm)
Lockout Cylinder	N/A	N/A
Steer Cylinder	N/A	N/A

Table 4-2. Holding Valve Torque Specifications

Description	Torque Value
Sun - 7/8 hex M20 x 1.5 thds	30 - 35 lb-ft (41 - 48 Nm)
Sun - 1-1/8 hex 1 - 14 UNS thds	45 - 50 lb-ft (61 - 68 Nm)
Sun - 1-1/4 hex M36 x 2 thds	150 - 153 lb-ft (204 - 207 Nm)
Racine - 1-1/8 hex 1-1/16 - 12 thds	50 - 55 lb-ft (68 - 75 Nm)
Racine - 1-3/8 hex 1-3/16 - 12 thds	75 - 80 lb-ft (102 - 109 Nm)
Racine - 1-7/8 hex 1-5/8 - 12 thds	100 - 110 lb-ft (136 - 149 Nm)

24. Prior to setscrew installation spot drill rod before installing the setscrew(s) which secure the piston attaching nut to the diameter groove.
25. Remove the cylinder rod from the holding fixture.
26. Position the cylinder barrel in a suitable holding fixture.

NOTICE

EXTREME CARE SHOULD BE TAKEN WHEN INSTALLING THE CYLINDER ROD, HEAD, AND PISTON. AVOID PULLING THE ROD OFF-CENTER, WHICH COULD CAUSE DAMAGE TO THE PISTON AND CYLINDER BARREL SURFACES.

27. With barrel clamped securely, and while adequately supporting the rod, insert the piston end into the barrel cylinder. Ensure that the piston loading o-ring and seal ring are not damaged or dislodged.
28. Continue pushing the rod into the barrel until the cylinder head gland can be inserted into the barrel cylinder.
29. If applicable, secure the cylinder head retainer using a suitable chain wrench.

30. After the cylinder has been reassembled, the rod should be pushed all the way in (fully retracted) prior to the reinstallation of any holding valve or valves.
31. If applicable, install the cartridge-type holding valve and fittings in the port block using new o-rings as applicable. Refer to Table 4-2, Holding Valve Torque Specifications.

4.5 DRIVE PUMP START-UP PROCEDURE

NOTICE

THE FOLLOWING PROCEDURE SHOULD ALWAYS BE PERFORMED WHEN STARTING A NEW PUMP OR WHEN RESTARTING AN INSTALLATION IN WHICH EITHER THE PUMP OR MOTOR HAVE BEEN REMOVED FROM THE SYSTEM.

THE FOLLOWING PROCEDURE SHOULD ALWAYS BE PERFORMED WHEN STARTING A NEW PUMP OR WHEN RESTARTING AN INSTALLATION IN WHICH EITHER THE PUMP OR MOTOR HAVE BEEN REMOVED FROM THE SYSTEM.

THE FOLLOWING PROCEDURE MAY REQUIRE THE MACHINE TO BE DISABLED (WHEELS RAISED OFF THE GROUND, DRIVE FUNCTION DISCONNECTED, ETC.) WHILE PERFORMING THE PROCEDURE IN ORDER TO PREVENT INJURY TO TECHNICIAN AND OTHER PERSONNEL. TAKE NECESSARY SAFETY PRECAUTIONS BEFORE MOVING THE MACHINE.

Prior to installing pump and/or motor, inspect unit(s) for damage incurred during shipping and handling. Make certain all system components (reservoir, hoses, valves, fittings, heat exchanger, etc.) are clean prior to filling with hydraulic fluid.

Fill reservoir with recommended hydraulic fluid, which should be passed through a 10 micron (nominal, no bypass) filter prior to entering the reservoir. The use of contaminated fluid will cause damage to components, which may result in unexpected machine movement.

The inlet line leading from the reservoir to the pump should be filled prior to start-up. Check inlet line for properly tightened fittings and make sure it is free of restrictions and air leaks.

Be certain to fill pump and/or motor housing with clean hydraulic fluid prior to start-up. Fill housing by pouring filtered oil into upper case drain port.

Install a 0 to 500 psi (0 to 35 bar) pressure gauge in the charge pressure gauge port to monitor charge pressure during start-up.

It is recommended that the external control input signal electrical connections be disconnected at the pump control until after initial start-up. This will allow the pump to remain in its neutral position.

“Jog” or slowly rotate prime mover until charge pressure starts to rise. Start prime mover and run at the lowest possible RPM until charge pressure has been established. Excess air may be bled from high pressure lines through high pressure gauge ports.

⚠ WARNING

DO NOT START PRIME MOVER UNLESS PUMP IS IN NEUTRAL POSITION (0 DEGREES SWASHPLATE ANGLE). TAKE PRECAUTIONS TO PREVENT MACHINE MOVEMENT IN CASE PUMP IS ACTUATED DURING INITIAL START-UP.

Once charge pressure has been established, increase speed to normal operating RPM. Charge pressure should be approximately 220 psi (15.5 bar) minimum. If charge pressure is incorrect, shut down and determine cause for improper pressure.

⚠ WARNING

INADEQUATE CHARGE PRESSURE WILL AFFECT THE OPERATOR'S ABILITY TO CONTROL THE MACHINE.

Shut down prime mover and connect external control input signal. Start prime mover, checking to ensure pump remains in neutral. With prime mover at normal operating speed, slowly check for forward and reverse machine operation.

Charge pressure should remain at 220 psi to 240 psi (15.5 bar to 16.9 bar) minimum during forward or reverse operation. Continue to cycle slowly between forward and reverse for at least five minutes.

Shut down prime mover, remove gauges, and plug ports. Check reservoir level and add fluid if necessary.

4.6 HYDRAULIC COMPONENT START-UP PROCEDURES & RECOMMENDATIONS

From a hydrostatic component standpoint, the goal at system start up is to put into functional operation, the hydrostatic system in such a way as to preserve the designed life span of the system. The following start-up procedure should be adhered to whenever a new pump or motor is initially installed into a machine, or a system is restarted after either a pump or motor has been removed and/or replaced.

⚠ WARNING

THE FOLLOWING PROCEDURE MAY REQUIRE THE MACHINE TO BE DISABLED (WHEELS RAISED OFF THE GROUND, WORK FUNCTIONS DISCONNECTED, ETC.) WHILE PERFORMING THE PROCEDURE IN ORDER TO PREVENT INJURY. TAKE NECESSARY SAFETY PRECAUTIONS BEFORE MOVING THE VEHICLE/MACHINE.

Prior to installing the pump and/or motor, inspect the unit(s) for damage that may have been incurred during shipping and handling. Ensure all system components (reservoir, hoses, valves, fittings, heat exchanger, etc.) are clean prior to filling with fluid.

Fill the reservoir with recommended hydraulic fluid. This fluid should be passed through a 10 micron (nominal, no bypass) filter prior to entering the reservoir. The use of contaminated fluid will cause damage to the components, which may result in unexpected vehicle/machine movement.

NOTE: *If a pump or motor is being replaced due to internal damage, the remaining units (pump or motors) need to be inspected for damage and contamination, and the entire hydraulic system will need to be flushed and the fluid replaced. Failure to do so may cause considerable damage to the entire system.*

The inlet line leading from the reservoir to the pump must be filled prior to start-up. Check the inlet line for property tightened fittings and make sure it is free of restrictions and air leaks.

NOTE: *In most cases, the reservoir is above the pump inlet so that the pressure head created by the higher oil level helps to keep the inlet pressures within an acceptable range and prevent high vacuum levels. However, due to hose routing or low reservoir locations, there may be air trapped within this line. It is important to ensure that the air is bled from this line. This can be accomplished by loosening the hose at the fitting closest to the pump. When oil begins to flow, the line is full, the air has been purged, and the fitting can be retightened to its specified torque. If the tank needs to be pressurized in order to start the flow of oil, a vacuum reading should be taken at the*

SECTION 4 - HYDRAULICS

inlet of the pump during operation in order to verify that the pump is not being asked to draw an inlet vacuum higher than it is capable of.

Be certain to fill the pump and/or motor housing with clean hydraulic fluid prior to start up. Fill the housing by pouring filtered oil into the upper case drain port.

NOTE: *It is highly recommended to use the highest possible case drain port, this ensures that the housing contains as much oil as possible and offers the greatest amount of lubrication to the internal components.*

In initial start-up conditions, it may be convenient to fill the housing, just prior to installing the case drain line. Component, (especially motor), location may be such that access to the case drain port after installation is not realistic.

Make certain that the oil being used to fill the component housing is as clean as possible. Store the fill container in such a way as to prevent it from becoming contaminated.

Install a 60 bar (or 1000 psi) pressure gauge in the charge pressure gauge port in order to monitor the charge pressure during start-up.

It is recommended that the external control input signal, (electrical connections for EDC), be disconnected at the pump control until after initial start-up. This will ensure that the pump remains in its neutral position.

⚠ WARNING

DO NOT START THE ENGINE UNLESS PUMP IS IN THE NEUTRAL POSITION (0 DEGREES SWASHPLATE ANGLE). TAKE PRECAUTIONS TO PREVENT MACHINE MOVEMENT IN CASE PUMP IS ACTUATED DURING INITIAL START-UP.

"Jog" or slowly rotate the engine until charge pressure starts to rise. Start the engine and run at the lowest possible RPM until charge pressure has been established. Excess air should be bled from the system lines as close to the motors as possible.

NOTE: *With the engine on low idle, "crack", (loosen-don't remove), the system lines at the motor(s). Continue to run the engine at low idle and tighten the system lines as soon as oil is observed to leak from them. When oil is observed to "leak" at the motor, the line is full, the air has been purged, and the system hoses should be retightened to their specified torque.*

Once charge pressure has been established, increase speed to normal operating RPM. Charge pressure should be as indicated in the pump model code. If charge pres-

sure is inadequate, shut down and determine the cause for improper pressure.

⚠ WARNING

INADEQUATE CHARGE PRESSURE WILL AFFECT THE OPERATOR'S ABILITY TO CONTROL THE MACHINE.

Shut down the engine and connect the external control input signal. Also reconnect the machine function(s), if disconnected earlier. Start the engine, checking to be certain the pump remains in neutral. With the engine at normal operating RPM, slowly check for forward and reverse machine operation.

Charge pressure may slightly decrease during forward or reverse operation. Continue to cycle slowly between forward and reverse for at least five minutes.

Shut down engine, remove gauges, and plug ports. Check reservoir level and add filtered fluid if needed.

The machine is now ready for operation.

4.7 HYDRAULIC GEAR PUMP

Overhaul pump only in a clean, dust free location, using clean tools and equipment. dirt and grit will damage the highly machined surfaces and will result in leakage or premature failure of the pump.

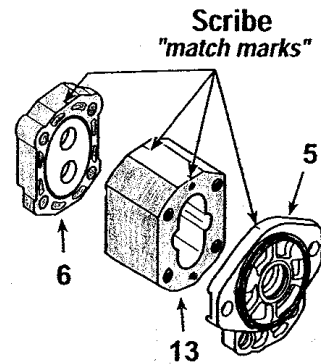

Before beginning disassembly, scribe "match marks" on the body (13) and covers (5 and 6) to ensure that the pump will be reassembled in the same manner as it was shipped from the factory. If the body or rear cover is replaced during overhaul, scribe a match mark on the new part in the same location as on the part it replaced.

Pump Disassembly

1. Clean outside of pump with a good grade solvent and dry thoroughly.
2. On models with a splined drive shaft, proceed to step 3. On models with a keyed drive shaft, remove drive key (10) from drive shaft. Using a file or stone, remove burrs from shaft end of keyway.

3. Using light clamping pressure on the ears of the front cover, secure unit in vise with shaft side down. Remove the cap screws (14) and washers (9).
4. Separate rear cover (6) from the body (13). The static seal (8) may remain either with the body or the cover. In either case, remove the static seal and discard.
5. Lift out the rear bearing block (2), drive gear (12), and driven gear (11).

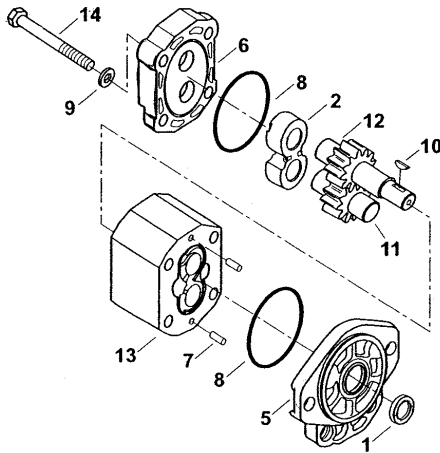

6. Separate body (13) from front cover (5). Dowel pins (7) and the front static seal (8) may remain with either the body (13) or the front cover (5). In either case, remove the static seal and discard.
7. The front bearing block (2) will typically remain in the body (13). Invert the body and lift out the bearing block.
8. Invert front cover (5) with shaft seal up. Remove the shaft seal (1) by prying it out with a large screwdriver.

NOTE: During disassembly, take special note of the wear patterns on the bearing blocks (2) and body (13). Relate these patterns to the inlet and outlet sides of the pump. The large port, whether in the body (13) or the rear cover (6), corresponds to the inlet side of the pump. The inlet side of the body can be identified by the gear contact pattern in the gear bore. The bearing block will have somewhat heavier wear patterns on the inlet side.

Parts Inspection

1. Wash all parts and dry thoroughly.
2. Inspect front and rear bearing block. Replace if scoring or uneven wear is observed.

NOTE: A somewhat heavier wear pattern is normal on the low pressure (inlet) side of the bearing blocks (2). However, there should be no heavy scoring in this area.

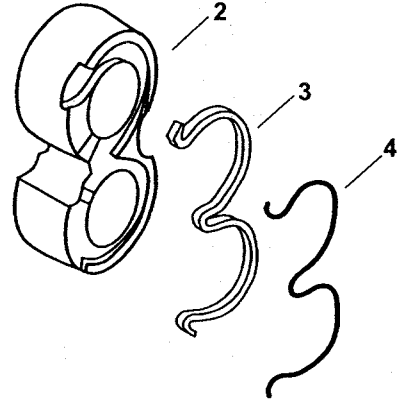

3. Remove anti extrusion seal (4) and pressure loading seal (3) from each bearing block and discard.
4. Inspect bushings in each bearing block (2). Replace bearing block if bushings are heavily scored or burned.
5. Inspect gear journals and faces. Replace if faces or journals are scored or worn.
6. Inspect body for wear and scoring. If gear contact wear on low pressure side (inlet) exceeds 0.005 in. (0.127mm) depth, replace body. If the body is usable, lightly wipe and remove burrs with suitable de-burring tool.

Pump Reassembly

1. Place the front cover (5) on a flat plate with the steel shaft seal bore up. Install new shaft seal (1). Press seal until it is 0.157 in (4.0mm) below front surface. Pack the area between the double lip of the seal with Lubriplate or an equivalent grease.

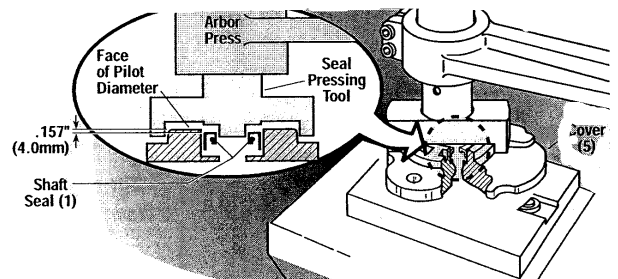

SECTION 4 - HYDRAULICS

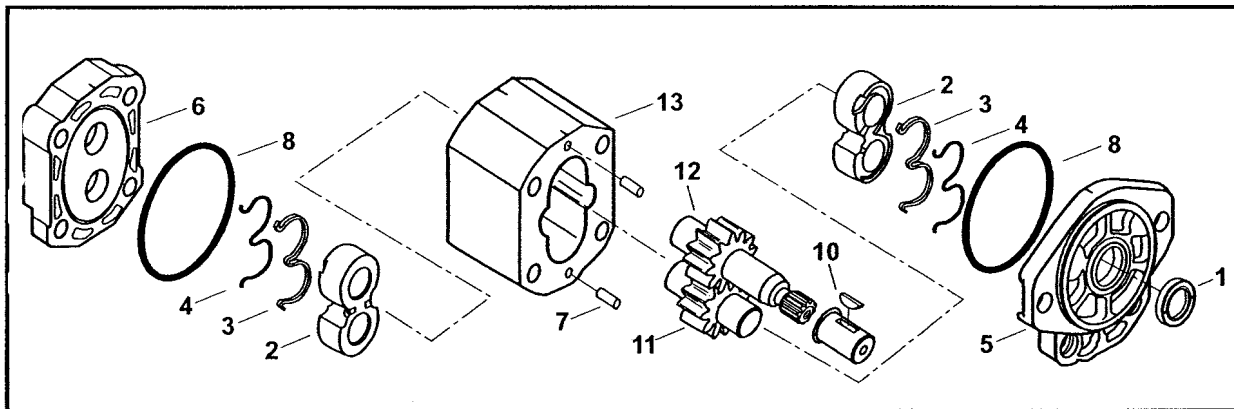
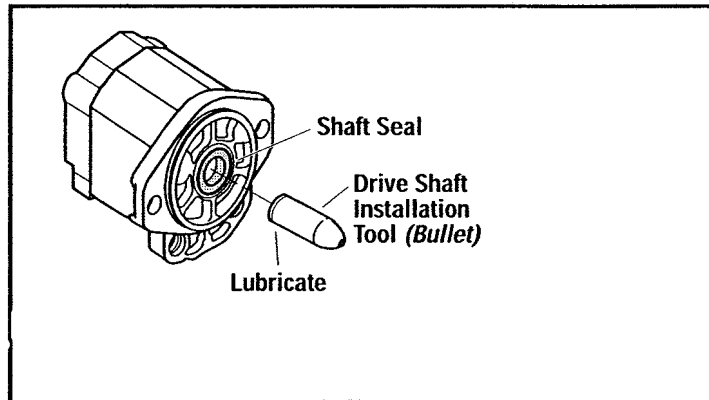
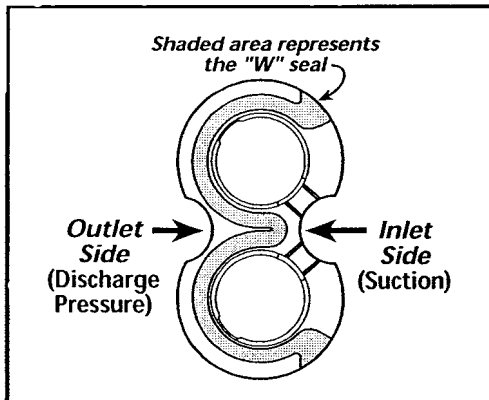

2. Clamp front cover into vise so that the ring groove is up. Apply a small amount of grease to the seal groove and install a new seal ring (8) into the groove.
3. Apply lubriplate or equivalent to outer surface of drive shaft installation tool. Insert tool (bullet) into shaft seal from seal ring groove side of front cover.
4. Place a small amount of grease on the seal groove on the front bearing block (2). Install a new load seal and anti extrusion seal in the groove. Insert the bearing block into the body, making sure that the load seal (3) and anti extrusion seal (4) are positioned properly. Ensure the outside of the "W" seal is exposed to the discharge pressure.
5. Apply a small amount of grease to the dowel pins (7) and install the pins into the body (13).
6. Set the body (13) onto the front cover (5), matching the scribe marks on the body and front cover. The dowel pins (7) should go into the mating holes on the front cover (5).
7. Install drive gear (12), and driven gear (11).
8. Place a small amount of grease in the seal groove on the rear bearing block (2). Install a new load seal and anti extrusion seal in the groove. Insert the bearing block into the body, making sure that the load seal and anti extrusion seal are positioned properly. Ensure the outside of the "W" seal is exposed to the discharge pressure.
9. Apply a small amount of grease to the seal groove in the rear cover (6) and install a new seal ring (8) into the groove. Set the rear cover (6) onto the body (13), matching the scribe marks on the body and rear cover.
10. Insert the cap screw (14) and washers (9); torque to 42-46 lb-ft. (57-62 Nm).
11. On models equipped with keyed drive shaft, install drive key (10).
12. With an adjustable wrench, check that the drive shaft turns without evidence of a mechanical bind.

4.8 VALVES

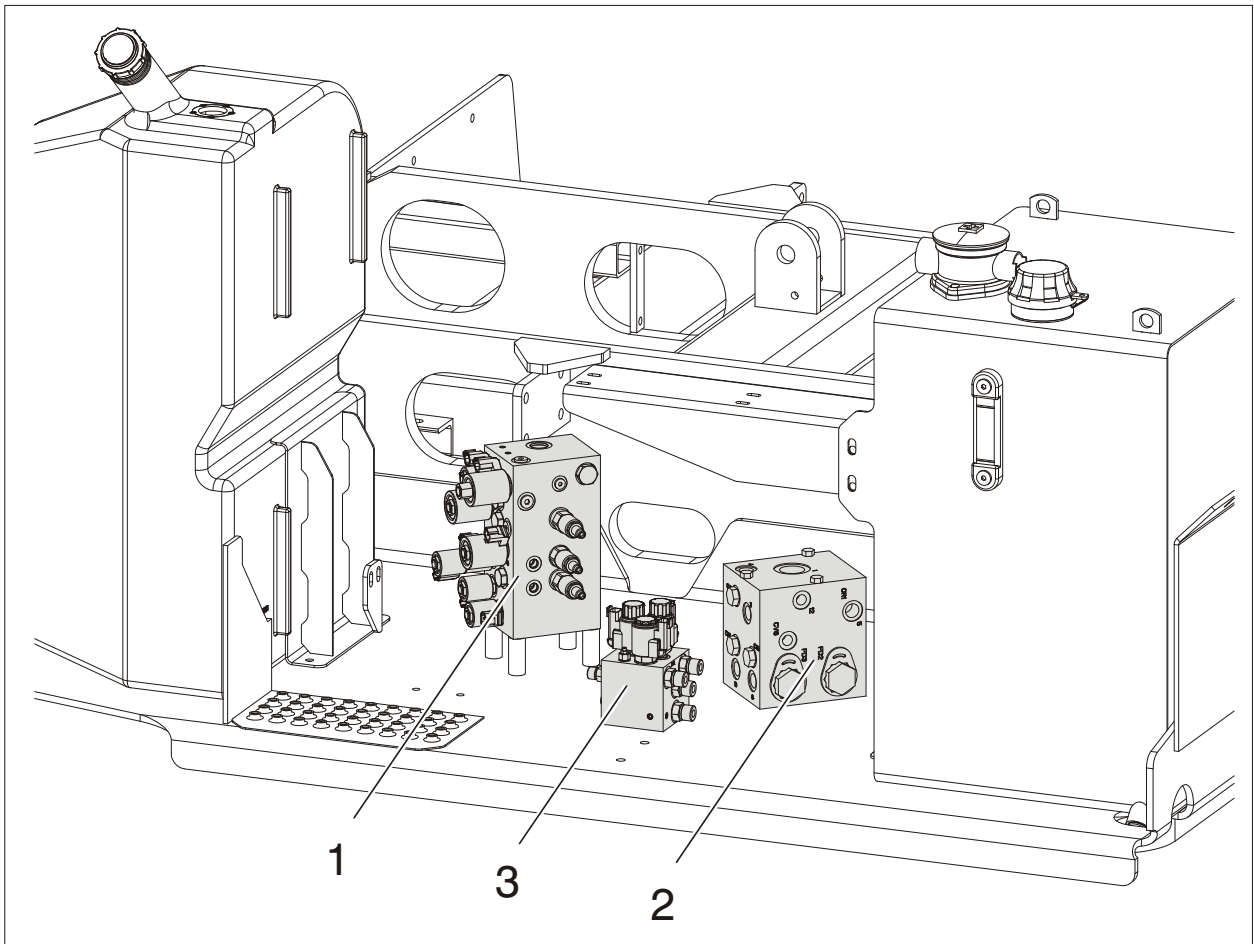

1. Main Valve

2. Flow Divider Valve

3. Outrigger Directional Valve

Figure 4-15. Hydraulic Compartment

REMOVAL:

1. Disconnect, cap and label all hydraulic hoses and any electrical harness connected to valves.
2. Remove the valve blocks from the hydraulic tray by removing the attaching bolts.

INSTALLATION:

1. Re-attach valve blocks to tray with bolts.
2. Re-connect all hydraulic lines and electrical harness.

Main Valve

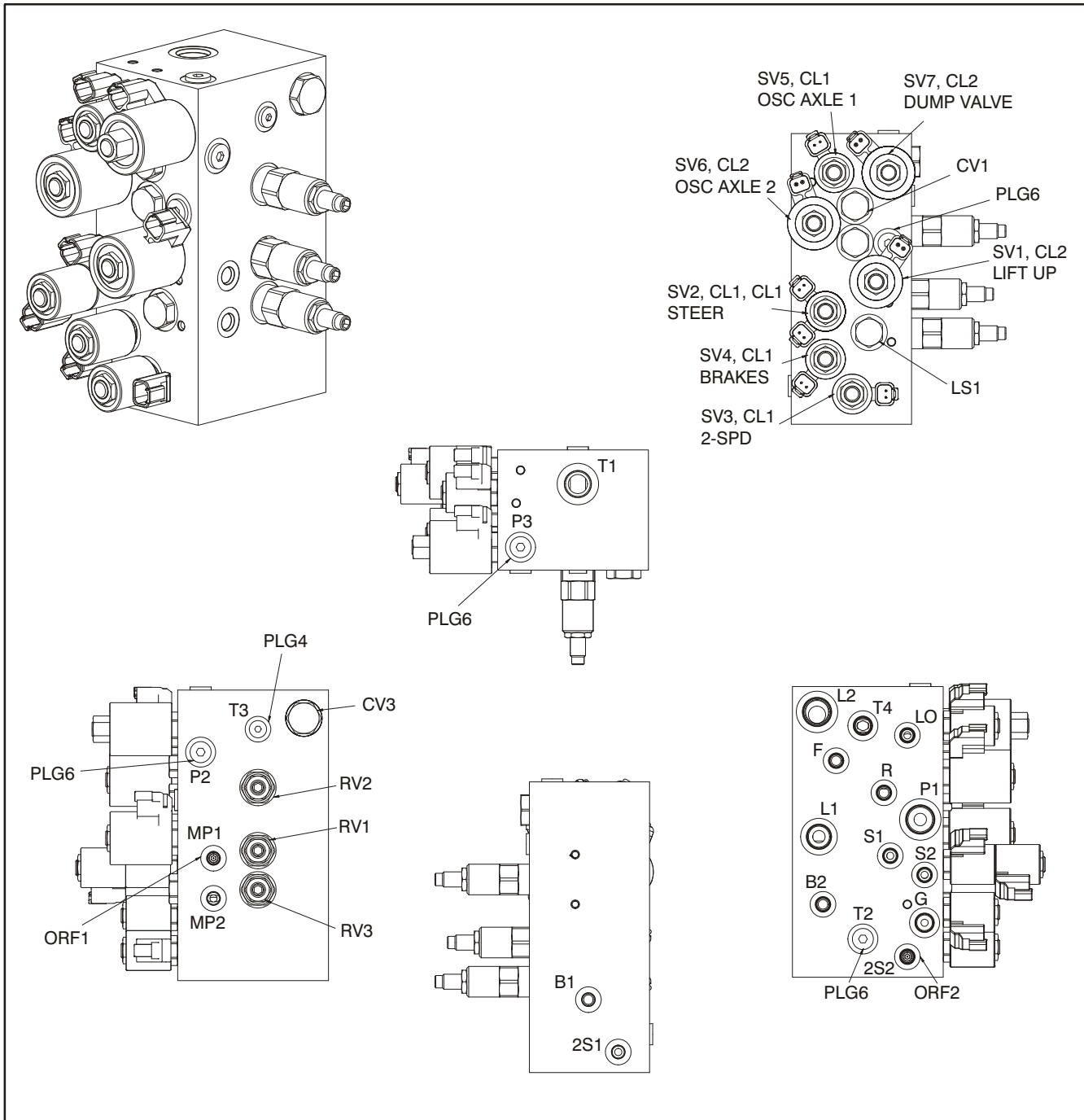

Figure 4-16. Main Valve Block

Table 4-3. Main Valve Torque Specs

Component	Torque
SV1 (Lift Up)	25 lb-ft (34.2 Nm)
SV2 (Steer)	20 lb-ft (27.3 Nm)
SV3 (2-Spd)	20 lb-ft (27.3 Nm)
SV4 (Brakes)	20 lb-ft (27.3 Nm)
SV5 (Osc Axle 1)	20 lb-ft (27.3 Nm)
SV6 (Osc Axle 2)	25 lb-ft (34.2 Nm)
SV7 (Dump Valve)	25 lb-ft (34.2 Nm)
CL1 & CL2 (Coil)	5 lb-ft (6.8 Nm)
RV1, RV2 & CV3	25 lb-ft (34.2 Nm)
RV3, LS1, CV1 & CV2	20 lb-ft (27.3 Nm)

Table 4-4. Porting Specs

Port	Size
L2, P1 & T1	SAE 10
L1	SAE 08
G, P2, P3, T4 & T2	SAE 06
All Others	SAE 04

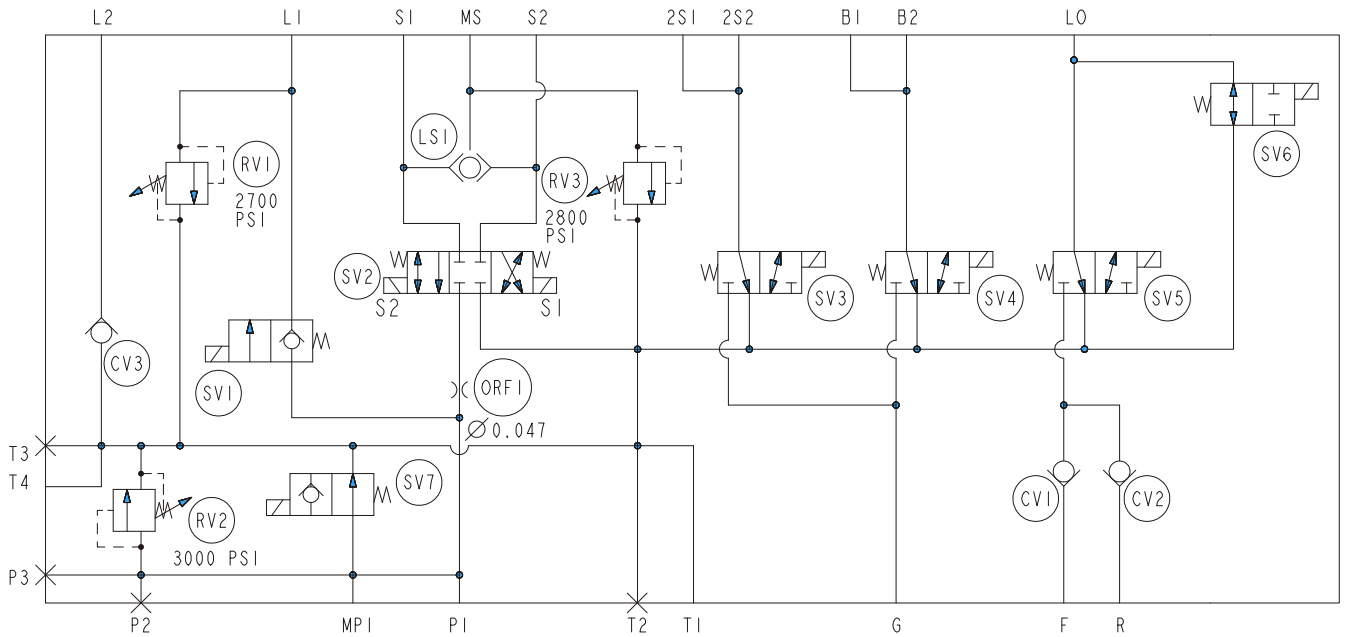

Figure 4-17. Main Valve Schematic

Flow Divider Valve

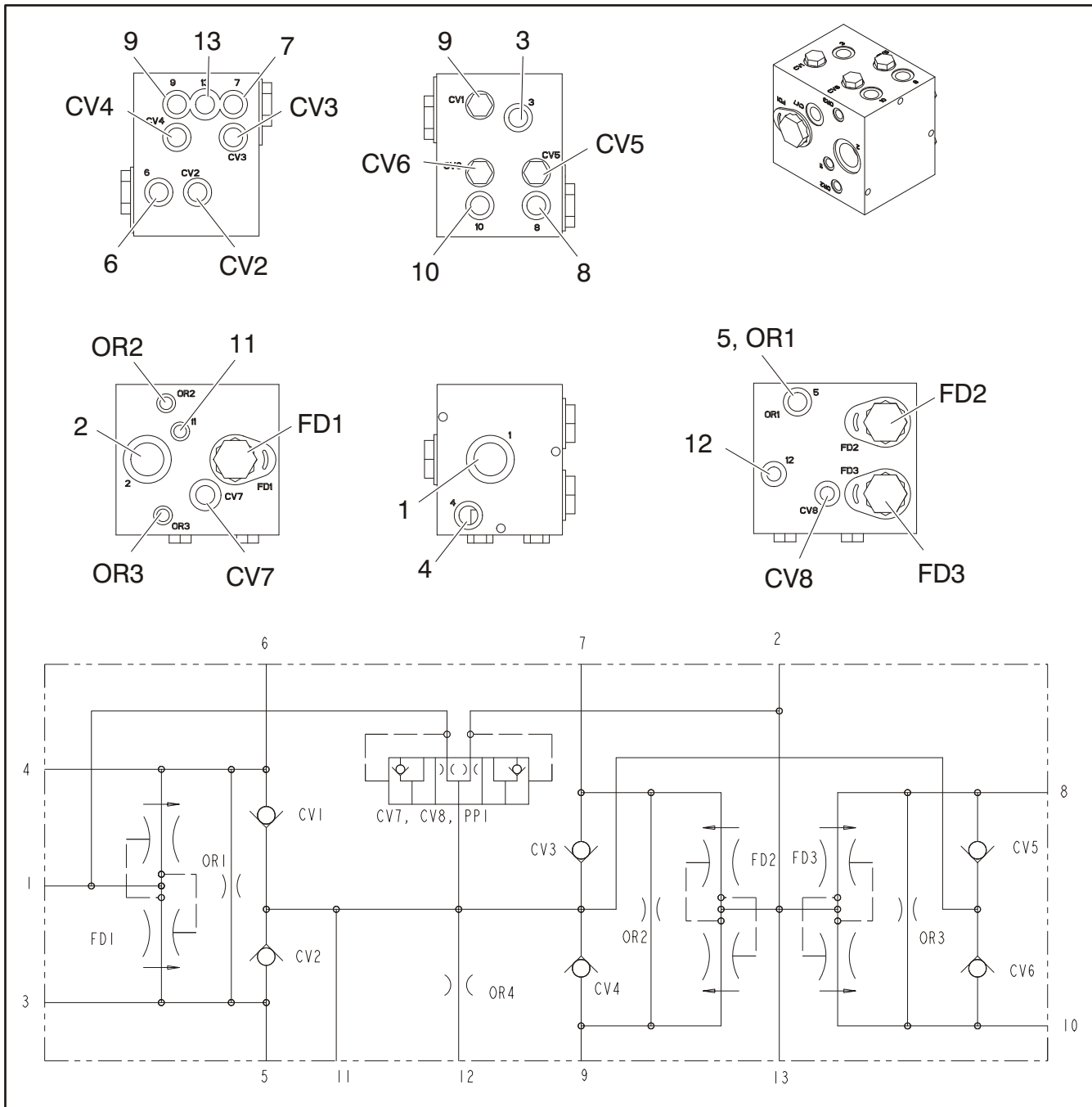

Figure 4-18. Flow Divider Valve

Leveling Jacks Directional Valve

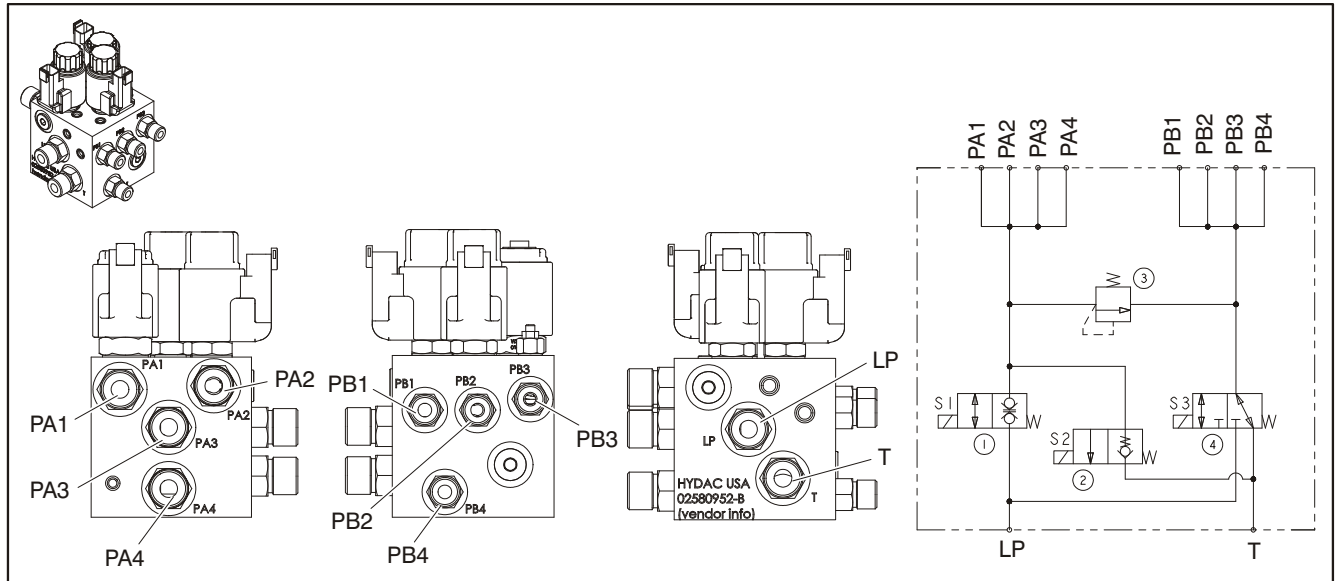

Figure 4-19. Leveling Jacks Directional Valve

Table 4-5. Leveling Jacks Directional Valve Torque Specs

Item	Torque
PA4	40 lb-ft (54 Nm)
PB4	23 lb-ft (31 Nm)
T	40 lb-ft (54 Nm)

Powerdeck Valves

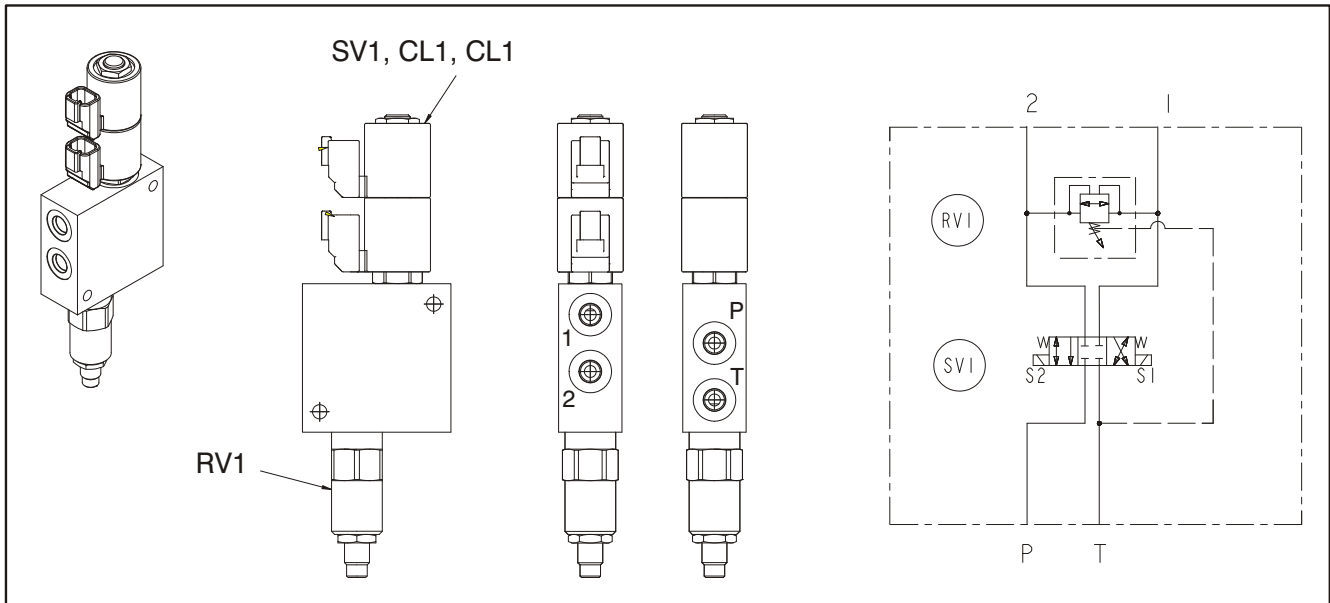

Figure 4-20. Powerdeck Valve (Single)

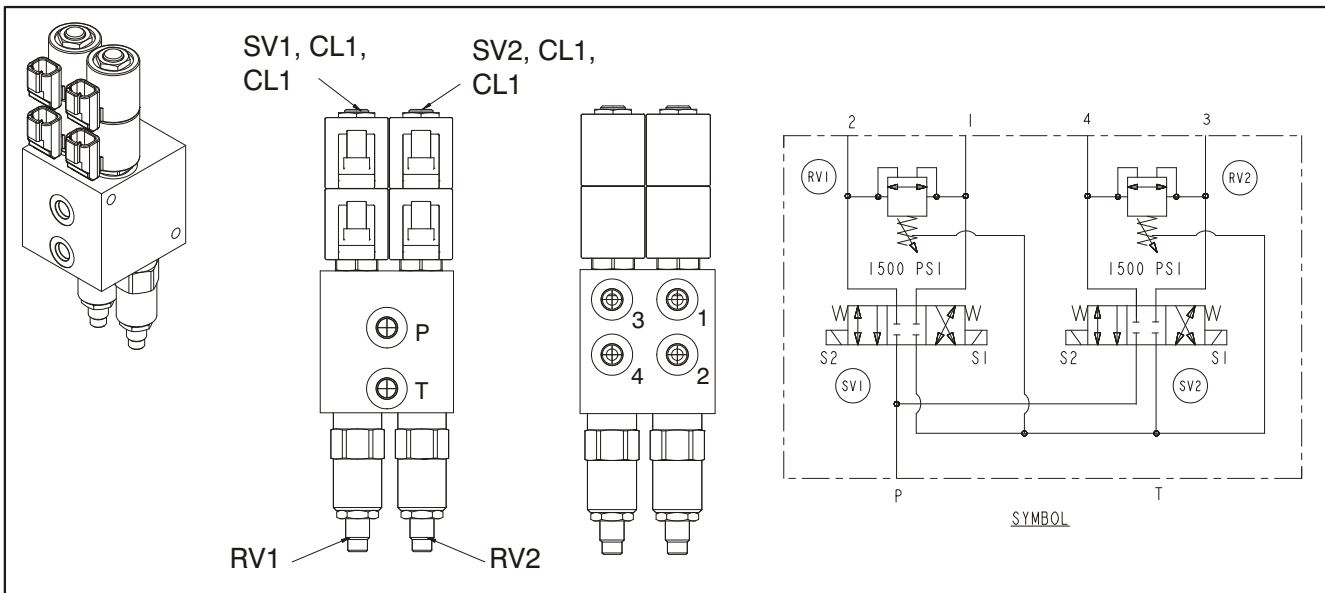

Figure 4-21. Powerdeck Valve (Double)

Table 4-6. Powerdeck Valve Torque Specs

NOTE: All ports are SAE 04.

Item	Torque
SV1, SV2	25 lb-ft (34.2 Nm)
CL1	5 lb-ft (6.8 Nm)
RV1, RV2	20 lb-ft (27.3 Nm)

Leveling Jack Valves

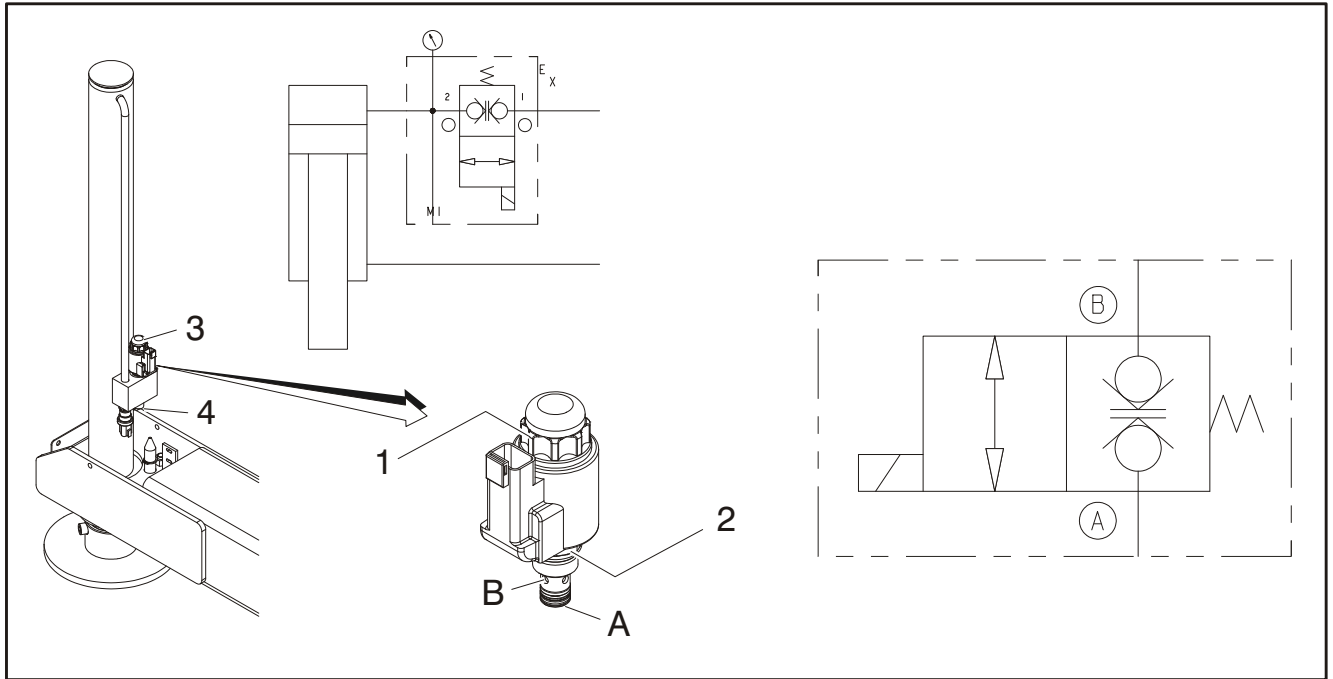

NOTE: Applies to all four Leveling Jacks.

Figure 4-22. Leveling Jack Valves

Table 4-7. Leveling Jack Valves Torque Specs

Item	Torque
1	3 to 4.5 lb-ft (4.1 to 6.1 Nm)
2	18.5 to 22 lb-ft (25.1 to 29.8 Nm)
3	40 lb-ft (54.2 Nm)
4	32 lb-ft (43.4 Nm)

Pressure Setting Procedures

Cold temperatures have a significant impact on pressure readings. JLG Industries Inc. recommends operating the machine until the hydraulic system has warmed to normal operating temperatures prior to checking pressures. JLG Industries Inc. also recommends the use of a calibrated gauge. Pressure readings are acceptable if they are within $\pm 5\%$ of specified pressures.

1. Main Relief
 - a. Refer to Figure 4-16., Main Valve Block.
 - b. Locate the lift up solenoid valve. Remove the coil nut and remove the coil from the cartridge. Do not remove the wire out of the coil plug.
 - c. Install a pressure gauge, 3000 psi (207 bar) or higher, at port MP1. Start the engine and activate lift up.
 - d. Gauge should read 3000 psi (207 bar).
 - e. Adjust the main relief (RV2) clockwise to increase, counter-clockwise to decrease.
 - f. Reinstall the coil to the cartridge and torque to 5 lb-ft (6.8 Nm).
2. Lift Up Relief Valve
 - a. Refer to Figure 4-16., Main Valve Block.
 - b. Install a pressure gauge, 3000 psi (207 bar) or higher, at port MP1. Start the engine and activate lift up.
 - c. Gauge should read 2700 psi (186 bar).
 - d. Adjust the lift up relief (RV1) clockwise to increase, counter-clockwise to decrease.
3. Steer Relief Valve
 - a. Refer to Figure 4-16., Main Valve Block.
 - b. Install a pressure gauge, 3000 psi (207 bar) or higher, at port MS. Start the engine and activate steer right or left.
 - c. Gauge should read 2500 psi (172 bar).
 - d. Adjust the steer relief (RV3) clockwise to increase, counter-clockwise to decrease. This relief valve takes care of both right and left.
4. Leveling Jack Retract Relief Valve
 - a. Refer to Figure 4-16., Main Valve Block.
 - b. Install a pressure gauge, 3000 psi (207 bar) or higher, at port MP1. Start the engine and activate jack retract.
 - c. When all jacks are retracted the gauge should read 2500 psi (172 bar).
 - d. Adjust the relief valve located on the leveling jack directional valve (refer to Figure 4-19.) clockwise to increase, counter-clockwise to

decrease. (The relief valve is on the same face as the solenoid valves).

5. Single Power Deck Relief Valve
 - a. Refer to Figure 4-20., Powerdeck Valve (Single).
 - b. A pressure gauge must be hosed in the power deck retract circuit. Tee the gauge in port 2 of the power deck valve.
 - c. Retract the power deck. Gauge should read 1500 psi (103 bar).
 - d. Adjust the relief valve (RV1) clockwise to increase, counter-clockwise to decrease.

NOTE: This type of relief valve is a bi-directional type. Port 2 is the primary setting. Port 1 is the secondary setting. Port 1 is a function of Port 2. When setting the primary setting, the secondary setting can be as much as 300 psi (21 bar) lower. In order to check Port 1, tee in a gauge at Port 1.

6. Dual Power Deck Relief Valve

Front Power Deck:

- a. Refer to Figure 4-21., Powerdeck Valve (Double).
- b. A pressure gauge must be hosed in the power deck retract circuit. Tee in a gauge at Port 4 of the dual deck valve.
- c. Retract the power deck. Gauge should read 1500 psi (103 bar).
- d. Adjust the relief valves (RV1, RV2) clockwise to increase, counter-clockwise to decrease.

NOTE: This type of relief valve is a bi-directional type. Port 4 is the primary setting. Port 3 is the secondary setting. Port 3 is a function of Port 4. When setting the primary setting, the secondary setting can be as much as 300 psi (21 bar) lower. In order to check Port 3, tee in a gauge at Port 3.

Rear Power Deck:

- a. Refer to Figure 4-21., Powerdeck Valve (Double).
- b. A pressure gauge must be hosed in the power deck retract circuit. Tee in a gauge at Port 2 of the dual deck valve.
- c. Retract the power deck. Gauge should read 1500 psi (103 bar).
- d. Adjust the relief valves (RV1, RV2) clockwise to increase, counter-clockwise to decrease.

NOTE: This type of relief valve is a bi-directional type. Port 2 is the primary setting. Port 1 is the secondary setting. Port 1 is a function of Port 2. When setting the primary setting, the secondary setting can be as much as 300 psi (21 bar) lower. In order to check Port 1, tee in a gauge at Port 1.

4.9 GEAR PUMP

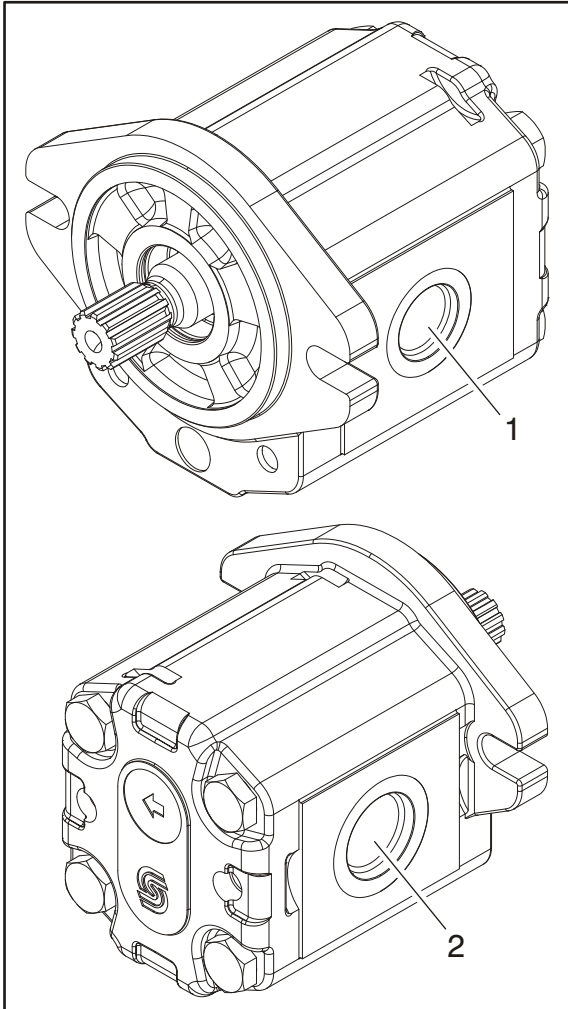

1. Outlet Port, 7/8-14UNF-2B
SAE #10
2. Inlet Port, 1-1/16-12UN-2B
SAE #16

Figure 4-23. Gear Pump

Table 4-8. Gear Pump Specs

Rotation (Viewing Drive End)	Clockwise
Displacement	0.878 in ³ /rev (14.4 cc/rev)
Max Rated Speed	3500 rpm
Rated Pressure	3625 psi (250 bar)
Minimum Speed at Rated Pressure	1000 rev/min

Gear Pump Priming

The gear pump is mounted with the suction hose up. Air trapped in this area can cause an air lock on start up. During this period, the pump is running dry, which can cause gear wear, which affects the volumetric efficiency of the pump.

To prime the pump:

1. Fill the hydraulic tank to the full mark.
2. Using a 2" wrench, loosen the suction hose fitting at the gear pump. The hose fitting does not need to be removed, just loosened enough to let the air escape.
3. When oil leaks at the hose end, re-torque the hose end to 115 lb-ft (Nm). The pump is primed and the machine is ready to start.

4.10 AXIAL HI 45 PUMP

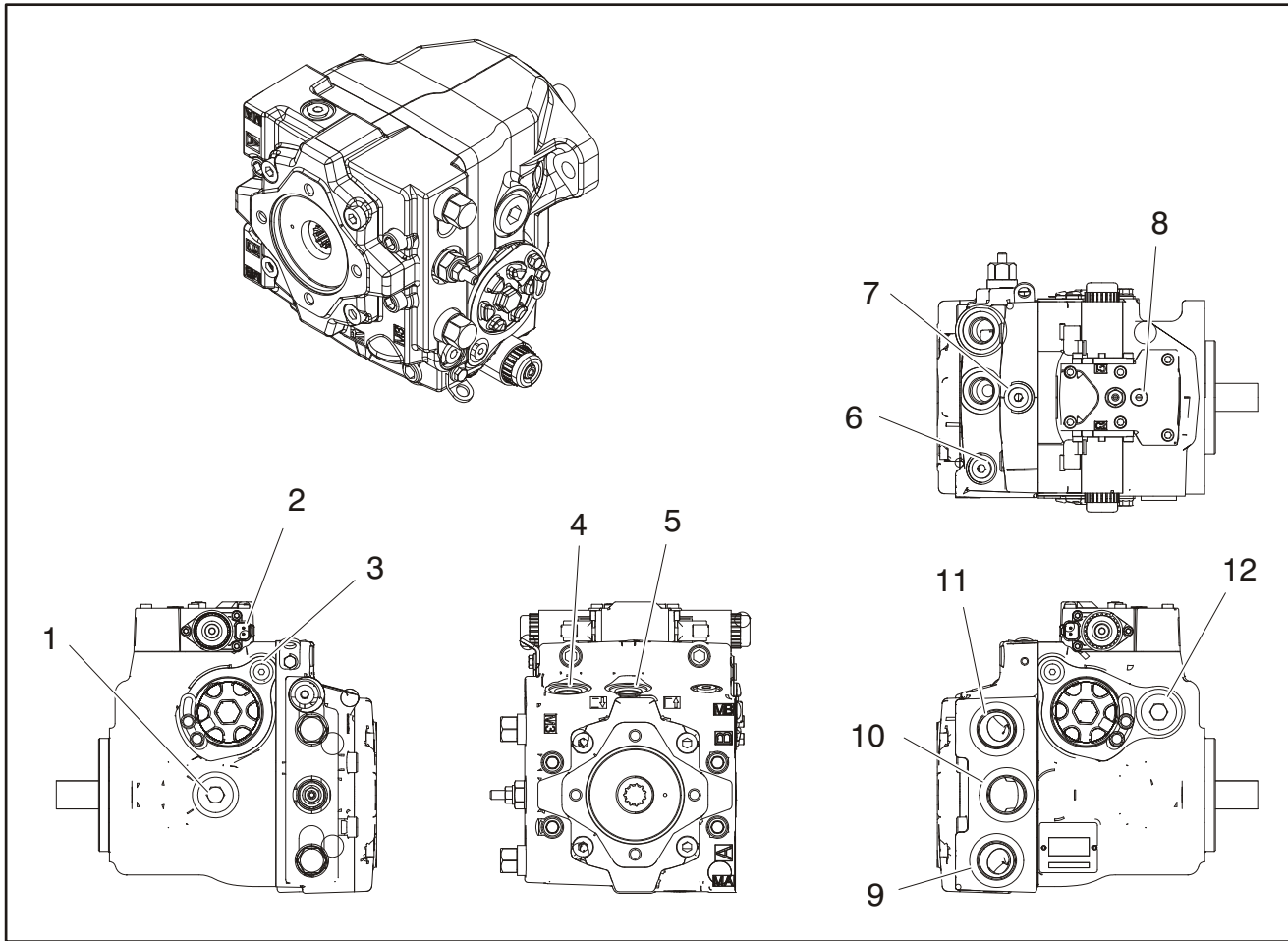

- | | | |
|--|---|---------------------------------------|
| 1. Case Drain Port L2 (SAE#12) | 5. Charge Pressure Filtration Port (to inlet on filter) | 9. Port A (SAE#16) |
| 2. Deutsch DT04-2P Connector | 6. MB Gage Port (SAE#6) | 10. Charge Pump Suction Port (SAE#16) |
| 3. M5 Servo Gage Port (SAE#4) | 7. M3 Charge Gage Port (SAE#6) | 11. Port B (SAE#16) |
| 4. Charge Pressure Filtration Port (from outlet on filter) | 8. M14 Gage Port (SAE#4) | 12. Case Drain Port L1 (SAE#12) |

Figure 4-24. Axial HI 45 Pump

Table 4-9. Axial HI 45 Pump Specs

Rotataion	Clockwise
Max Pressure	6525 psi (450 bar)
Displacement	2.75 in ³ (45 cm ³)
Control Current	755 mA Threshold 1640 mA Max Displacement
12 CC Charge Pump Pressure	348 psi (24 bar)
Max Operating Speed	3500 rpm

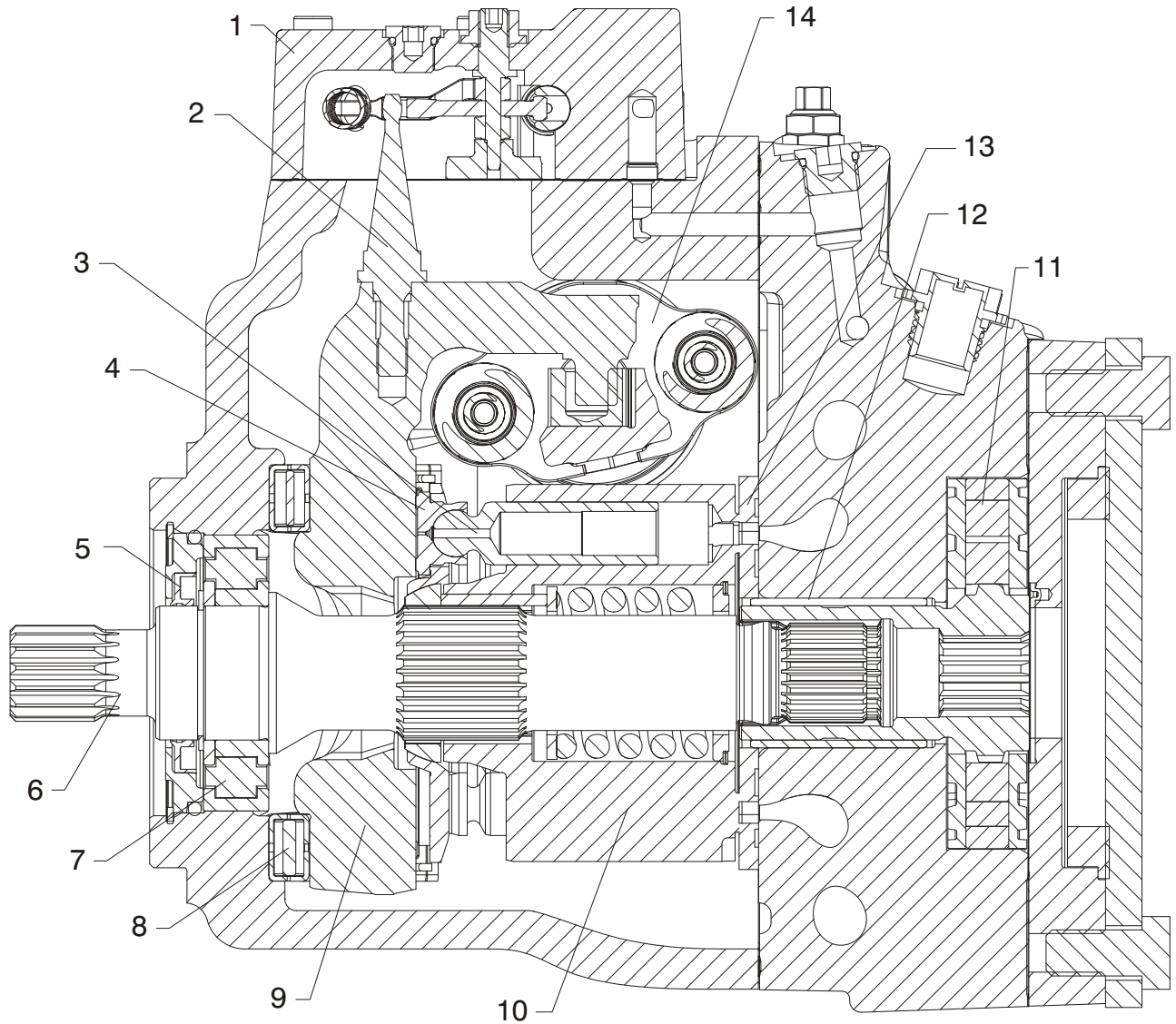

- | | | |
|----------------------------------|-----------------------|------------------|
| 1. Electric Displacement Control | 6. Shaft | 11. Charge Pump |
| 2. Swashplate Feedback Pin | 7. Front Bearing | 12. Rear Bearing |
| 3. Piston | 8. Swashplate Bearing | 13. Valve Plate |
| 4. Slipper | 9. Swashplate | 14. Servo Piston |
| 5. Shaft Seal | 10. Cylinder Block | |

Figure 4-25. Axial HI 45 Pump - Cross Section View

General Repair Instructions

REMOVAL:

⚠ CAUTION

PRIOR TO PERFORMING REPAIRS, REMOVE THE UNIT FROM THE MACHINE. CHOCK WHEELS ON THE MACHINE TO INHIBIT MOVEMENT. BE AWARE THAT HYDRAULIC FLUID MAY BE UNDER HIGH PRESSURE AND/OR HOT. INSPECT THE OUTSIDE OF THE PUMP AND FITTINGS FOR DAMAGE. CAP HOSES AFTER REMOVAL TO PREVENT CONTAMINATION.

KEEP IT CLEAN

Clean the outside of the pump thoroughly before disassembly. Take care not to contaminate system ports. Clean parts using a clean solvent wash and air dry.

NOTICE

AS WITH ANY PRECISION EQUIPMENT, YOU MUST KEEP ALL PARTS FREE OF FOREIGN MATERIAL AND CHEMICALS. PROTECT ALL EXPOSED SEALING SURFACES AND CAVITIES FROM DAMAGE AND FOREIGN MATERIAL. IF LEFT UNATTENDED, COVER THE PUMP WITH A PROTECTIVE LAYER OF PLASTIC.

REPLACE ALL O-RINGS & GASKETS

Replace all o-rings and seals during service. Lightly lubricate o-rings with clean petroleum jelly prior to assembly.

SECURE THE UNIT

Place the unit in a stable position with the shaft pointing downward. It will be necessary to secure the pump while removing and torquing fasteners and components.

NOTICE

PERFORMING MINOR REPAIRS ACCORDING TO THIS SECTION WILL NOT AFFECT THE PUMP'S WARRANTY. MAJOR REPAIRS REQUIRING THE REMOVAL OF THE UNIT'S CENTER SECTION, SERVO SLEEVES, OR FRONT FLANGE VOIDS WARRANTY.

Start-Up Procedure

Follow this procedure when starting-up a new pump installation or when restarting an installation in which the pump has been removed and re-installed on the machine. Ensure pump has been thoroughly tested on a test stand before installing on a machine.

These pumps should never be dry started. The time it takes for the charge pump to create a vacuum to draw in the fluid, send it out through the charge pump filter and then back in to the pump may take 30-40 seconds. During this time the surface between the cylinder barrel and valve plate are running dry. This can affect the volumetric efficiency of the pump and cause premature failure of the pump. Pre-filling the case also reduces the time it takes for the pump to create a vacuum to draw fluid into the pump.

⚠ WARNING

TO PROTECT AGAINST UNINTENDED MOVEMENT, SECURE THE MACHINE OR DISABLE/DISCONNECT THE MECHANISM WHILE SERVICING.

NOTE: Prior to installing the pump, inspect for damage that may have occurred during shipping.

1. Ensure that the machine hydraulic oil and system components (reservoir, hoses, valves, fittings, and heat exchanger) are clean and free of any foreign material.
2. Install new system filter element(s) if necessary. Check that inlet line fittings are properly tightened and there are no air leaks.
3. Install the pump. Install a 1000 psi (50 bar) gauge in the charge pressure gauge port M3.
4. Fill the housing by adding filtered oil in the upper case drain port. If the control is installed on top, open the construction plug in the top of the control to assist in air bleed.
5. Fill the reservoir with hydraulic fluid of the recommended type and viscosity. Use a 10-micron filler filter. Fill inlet line from reservoir to pump. Ensure construction plug in control is closed after filling.
6. Disconnect the pump from all control input signals.
7. Close construction plug removed in step 4.

NOTICE

AFTER START-UP, THE FLUID LEVEL IN THE RESERVOIR MAY DROP DUE TO SYSTEM COMPONENTS FILLING. DAMAGE TO HYDRAULIC COMPONENTS MAY OCCUR IF THE FLUID SUPPLY RUNS OUT. ENSURE RESERVOIR REMAINS FULL OF FLUID DURING START-UP.
AIR ENTRAPMENT IN OIL UNDER HIGH PRESSURE MAY DAM-

AGE HYDRAULIC COMPONENTS. CHECK CAREFULLY FOR INLET LINE LEAKS.**DO NOT RUN AT MAXIMUM PRESSURE UNTIL SYSTEM IS FREE OF AIR AND FLUID HAS BEEN THOROUGHLY FILTERED.**

8. Disable the engine to prevent it from starting. Crank the starter for several seconds. Do not exceed the engine manufacturer's recommendation. Wait 30 seconds and then crank the engine a second time as stated above. This operation helps remove air from the system lines. Refill the reservoir to recommended full oil level.
9. When the gauge begins to register charge pressure, enable and start engine. Let the engine run for a minimum of 30 seconds at low idle to allow the air to work itself out of the system. Check for leaks at all line connections and listen for cavitation. Check for proper fluid level in reservoir.
10. When adequate charge pressure is established (as shown in model code), increase engine speed to normal operating rpm to further purge residual air from the system.
11. Shut off engine. Connect pump control signal. Start engine, checking to be certain pump remains in neutral. Run engine at normal operating speed and carefully check for forward and reverse control operation.
12. Continue to cycle between forward and reverse for at least five minutes to bleed all air and flush system contaminants out of loop.

NOTE: Normal charge pressure fluctuation may occur during forward and reverse operation.

13. Check that the reservoir is full. Remove charge pressure gauge. The pump is now ready for operation.

Removing the pump**NOTICE**

CONTAMINATION CAN DAMAGE INTERNAL COMPONENTS AND VOID THE MANUFACTURER'S WARRANTY. TAKE PRECAUTIONS TO ENSURE SYSTEM CLEANLINESS WHEN REMOVING AND INSTALLING SYSTEM LINES.

DISASSEMBLY:

1. With the prime mover off, thoroughly clean all dirt and grime from the outside of the pump.
2. Tag, disconnect, and cap each hydraulic line connected to the pump. As hydraulic lines are disconnected, plug each open port, to ensure that dirt and contamination do not get into the pump.
3. Remove the pump and its auxiliary pump (if applicable) as a single unit.

NOTE: Be careful, do not damage solenoids and electrical connections when using straps or chains to support the pump.

INSPECTION:

4. Ensure the work surface and surrounding area are clean and free of contaminants such as dirt and grime.
5. Inspect the system for contamination.
6. Look at the hydraulic fluid for signs of system contamination, oil discoloration, foam in the oil, sludge, or metal particles.

REASSEMBLY:

7. Before replacing the pump, replace all filters and drain the hydraulic system. Flush the system lines and fill the reservoir with the correct, filtered hydraulic fluid.
8. Fill the pump with clean, filtered hydraulic fluid.
9. Attach the pump to the prime mover. Torque mounting screws according to the manufacturers recommendation.
10. Replace all hydraulic lines. Ensure the charge inlet line is filled with fluid.

Electric Control Module

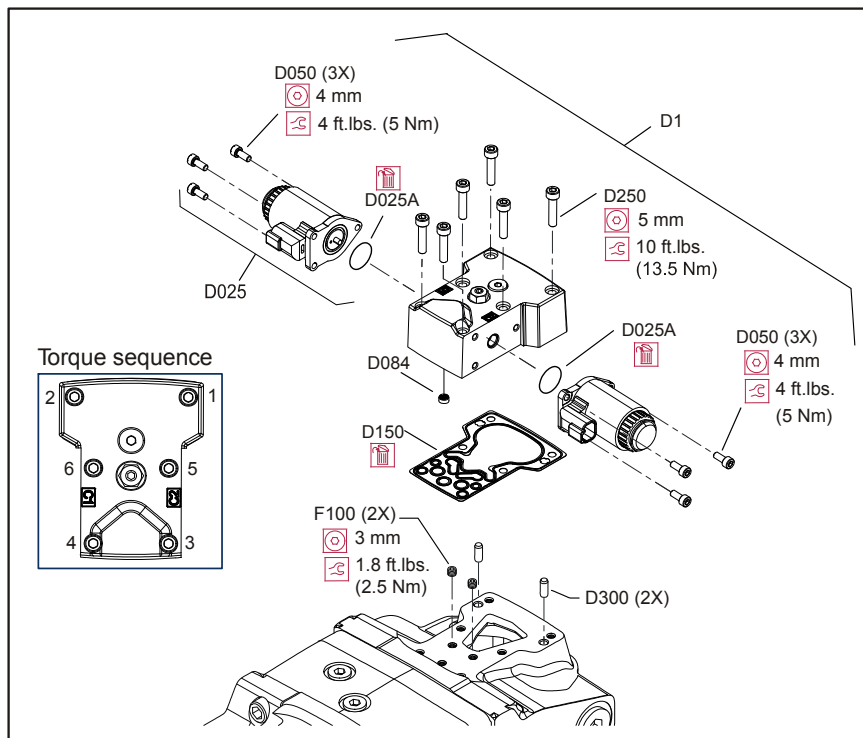

REMOVAL:

1. Using a 5 mm internal hex wrench, remove the six cap screws (D250).
2. Remove the control module and gasket (D150). Discard the gasket.
3. If necessary, remove orifices (F100) using a 3 mm internal hex wrench. Tag and number them for reinstallation.

INSPECTION:

4. Inspect the machined surfaces on the control and top of the pump. If you find any nicks or scratches, replace the component.

REASSEMBLY:

NOTE: Ensure you install dowel pins (D300) in housing before installing control.

5. Install a new gasket (D150).
6. If you removed screen (D084), install a new one. Install with the mesh facing outward (see drawing).
7. If previously removed, install orifices (F100) using a 3 mm internal hex wrench. Torque to 1.8 lb-ft (2.5 Nm).

8. Install the control module and six cap screws (D250).
9. Using a 5 mm internal hex wrench, torque the cap screws (D250) to 10 lb-ft (13.5 Nm).

Control Solenoids

REMOVAL:

1. Disconnect electrical connection and remove the three cap screws (D050) using a 4 mm internal hex wrench.
2. Remove the solenoid (D025) and O-ring (D025A). Discard the O-ring.
3. If necessary, remove the coil using a 12 point 26 mm socket.

INSPECTION:

4. Inspect the machined surface on the control. If you find any nicks or scratches, replace the component.

REASSEMBLY:

5. Lubricate new O-ring (D025A) using petroleum jelly and install.

6. Install solenoid with three cap screws (D050) using a 4 mm internal hex wrench. Torque screws to 5 Nm (4 lb-ft).
7. Install coil using a 12 point 26 mm socket. Torque coil nut to 3.7 lb-ft (5 Nm).
8. Reconnect electrical connections and test the pump for proper operation.

Shaft Seal, Roller Bearing & Shaft Replacement

NOTE: The shaft assembly is serviceable without disassembling the pump. Orient the pump on the work surface so the shaft is pointing to the side.

REMOVAL:

1. Unwind the spiral ring (J300) from the housing to release the shaft/seal/bearing subassembly.
2. Pry on the lip of the seal carrier (J275) to dislodge it from the pump. Remove the seal carrier. Remove and discard O-ring (J260). Press the seal (J250) out of the carrier and discard.
3. Pull the shaft (J100) with bearing (J150) out of the pump. If necessary, tap lightly on the shaft to dislodge it from the cylinder block.
4. Remove the retaining ring (J200) using retaining ring pliers. Press the bearing off the shaft.

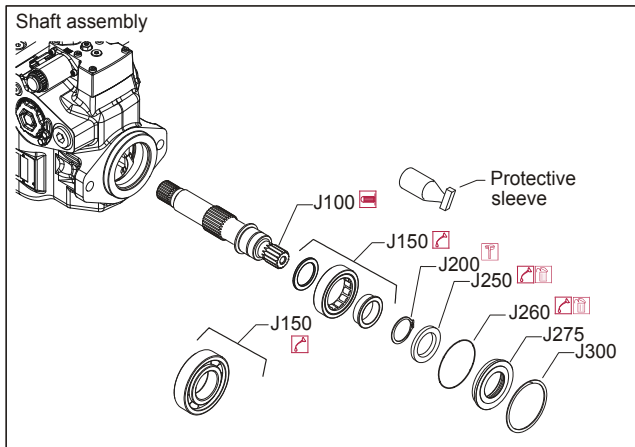

INSPECTION:

5. Inspect the shaft journals for wear, scratching, and pits. Check the splines for fretting; replace if damaged. Rotate the bearing, if it does not rotate smoothly, replace it.

REASSEMBLY:

6. Press the bearing (J150) onto the shaft (J100) and replace the retaining ring (J200). Ensure the retain-

ing ring diameter is less than 1.53 in (38.84 mm) when installed on the shaft.

7. Install the shaft/bearing assembly into the pump.
8. Lubricate and install a new O-ring (J260) onto seal carrier (J275). Press a new seal (J250) into the seal carrier. Press the seal until it is flush within 0.005 in (+0.12mm) or 0.0028 in (-0.72 mm) of the inside lip of the carrier: see illustration.

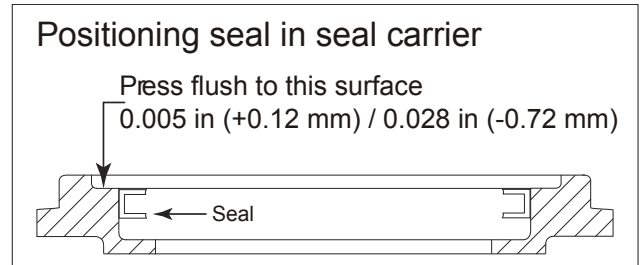

9. Cover the shaft with a protective sleeve while installing the seal carrier. Hand press the seal carrier into the housing. Ensure the seal carrier clears the spiral ring groove in the housing. Remove the protective sleeve.
10. Wind the spiral ring into the housing. Ensure the inside diameter of the spiral ring is greater than 2.677 in (68 mm) after installation.

Charge Pump

If the pump has an auxiliary pump attached, remove the auxiliary pump and connecting shaft before removing the auxiliary pad.

REMOVAL:

1. Position pump so end cover or auxiliary pad is on top.
2. If necessary, remove auxiliary pump (not shown), or shipping cover (K300) and pad seal (K250) as shown on following page.
3. Remove end cover/auxiliary pad screws (K400) using a 10 mm internal hex wrench.

NOTE: Alignment pins (G450) are in end cover. They may dislodge during disassembly.

4. Remove and discard gasket (K150).
5. Remove thrust washer (K500). Note thrust washer orientation.
6. Use a small hook to remove pressure balance plate (S200) and seal (S300). Note plate orientation. Discard seal.
7. Remove coupling (K200). Use a small hook if necessary.

SECTION 4 - HYDRAULICS

8. Remove the charge pump outer ring (S150), and gearset (S100).
9. Remove valve plate (S250) with seal (S300). Discard seal

INSPECTION:

10. Inspect the components for wear, scratches or pitting. Carefully inspect the valve and pressure-balance plates. Scratches on these components will cause a loss of charge pressure. If any component shows signs of wear, scratching or pitting, replace it.

REASSEMBLY:

11. Install new seals (S300) in the valve (S250) and pressure-balance (S200) plates.
12. Install valve plate (S250) in the same orientation as removed.
13. Lubricate and install charge pump (S100) and outer ring (S150).
14. Install charge pump coupling (K200).
15. Install pressure balance plate (S200) in the same orientation as removed.
16. Install the thrust washer (K500). Coated side goes toward charge pump coupling (K200).
17. Install a new cover gasket. (K150). If removed, install guide pins (K450).
18. Install the auxiliary pad or charge pump cover and cap screws. Using a 10mm internal hex wrench, torque the cap screws (K400) to 68 lb-ft (92 Nm). Torque in sequence below.
19. Reinstall auxiliary pump or pad seal (K250) and shipping cover (K300).

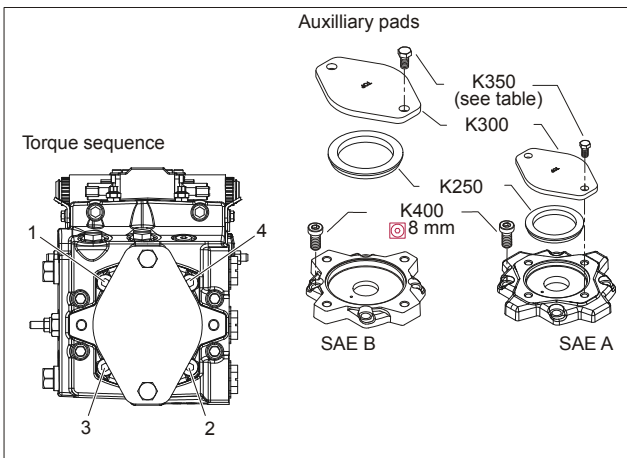
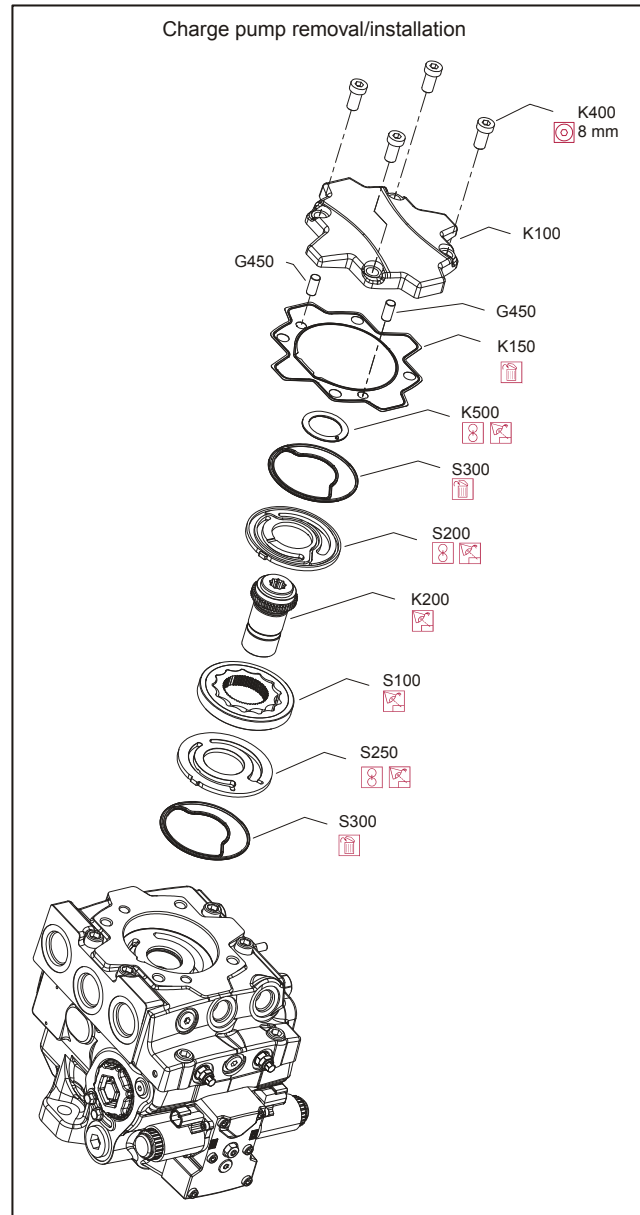

Cover Screw K350

Cover Pad	Wrench Size; Torque
A	17 mm; 35 lb-ft (48 Nm)
B, C	19 mm; 58 lb-ft (77 Nm)

Charge Check/HPRV

REMOVAL:

1. Using a 22 mm hex wrench, remove the HPRVs (L100/L200). Remove and discard the O-rings (L060) and backup rings (L068).

INSPECTION:

2. Inspect the sealing surfaces in the pump for nicks or scratches. Check the valves for damage. Replace any damaged components.

REASSEMBLY:

3. Lubricate and install new backup rings (L068) and O-rings (L060).
4. Install HPRVs. Torque to the value in the illustration below.
5. Operate the machine through full range of controls to ensure proper operation. Check for leaks.

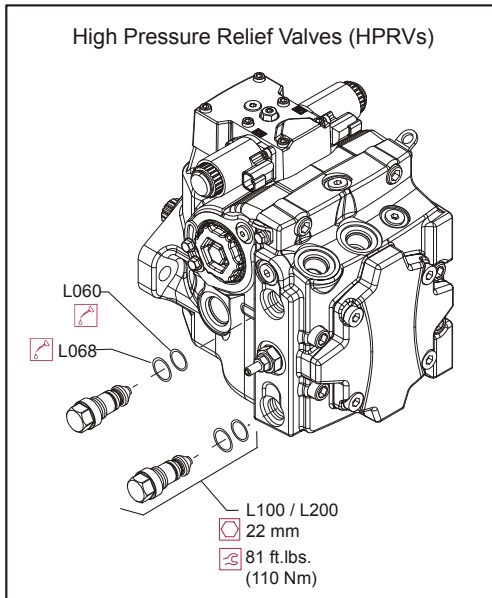

Charge Pressure Relief Valve

Replace the charge pressure relief valve (V10) as a complete unit. Do not attempt to repair the internal components of the valve. Torque to 38 lb-ft (52 Nm).

REMOVAL:

1. Using a 22 mm wrench, remove the charge pressure relief valve (V10). Discard seal (V024).

INSPECTION:

2. Inspect the sealing surfaces of the pump for nicks or scratches.

REASSEMBLY:

3. Lubricate and install new seal (V024).
4. Install the charge pressure relief valve. Torque to 38 lb-ft (52 Nm).
5. Operate machine through full range of controls to ensure proper operation.

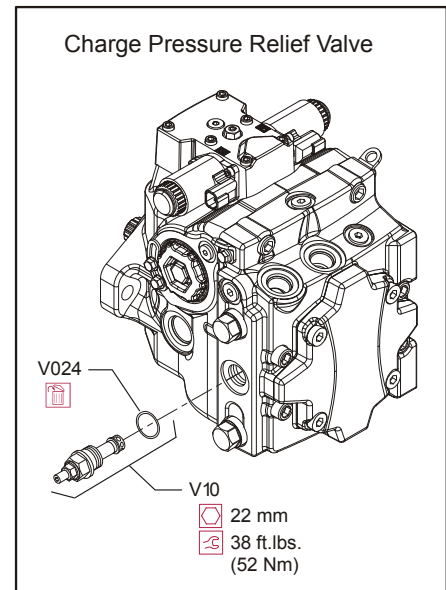

Pressure Limiter Valve Replacement

NOTE: Replace the pressure limiter valve as a complete unit. Do not attempt to repair individual components.

REMOVAL:

1. Using a 14 mm wrench, remove the pressure limiter valves (L300/L400). Discard O-rings.

INSPECTION:

2. Inspect the sealing surfaces of the pump for nicks or scratches.

REASSEMBLY:

3. Install new O-ring. Lubricate O-ring with petroleum jelly.
4. Replace pressure limiter valves. Torque to 22 lb-ft (30 Nm).
5. Operate pump at full range of controls to ensure proper machine operation.

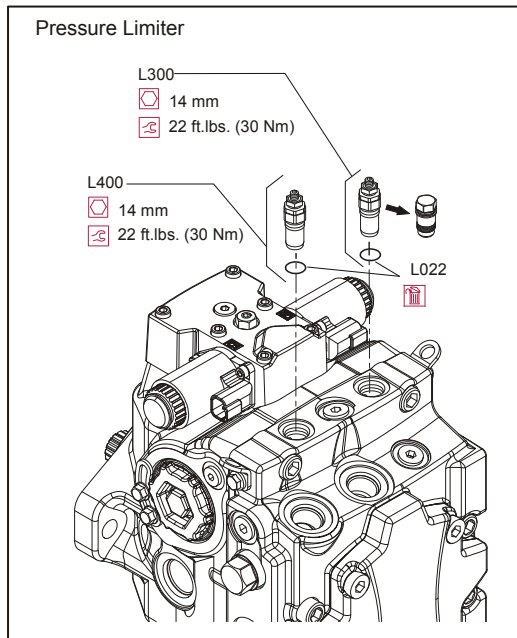

4.11 CHARGE PUMP FILTER

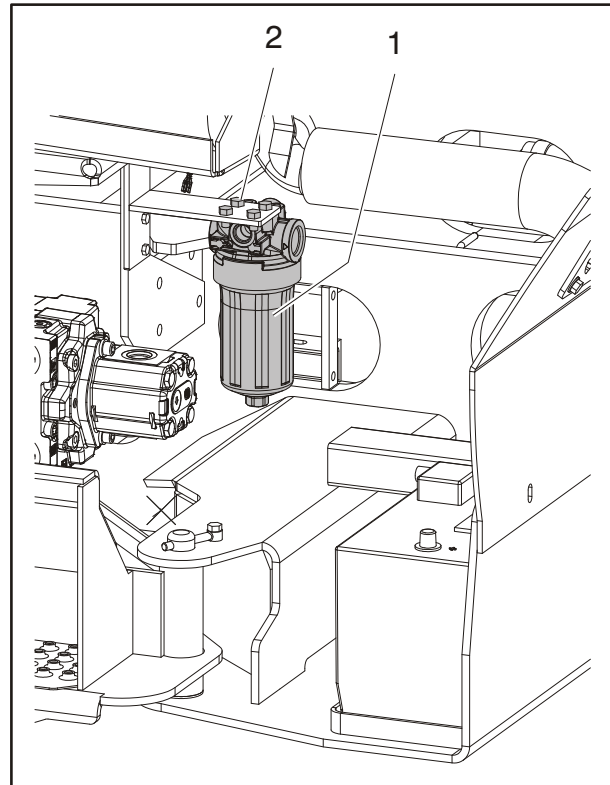

1. Charge Pump Filter
2. Bolt, 3/8"-16NC x 5/8"20

Figure 4-26. Charge Pump Filter

REMOVAL:

1. Disconnect and cap the hydraulic lines on the filter (1).
2. Remove the four bolts (2) to remove the filter from the bracket.

INSTALLATION:

1. Attach filter (1) to bracket using the four bolts (2).
2. Uncap and reconnect the hydraulic lines to the filter.

4.12 AUXILIARY PUMP MOTOR

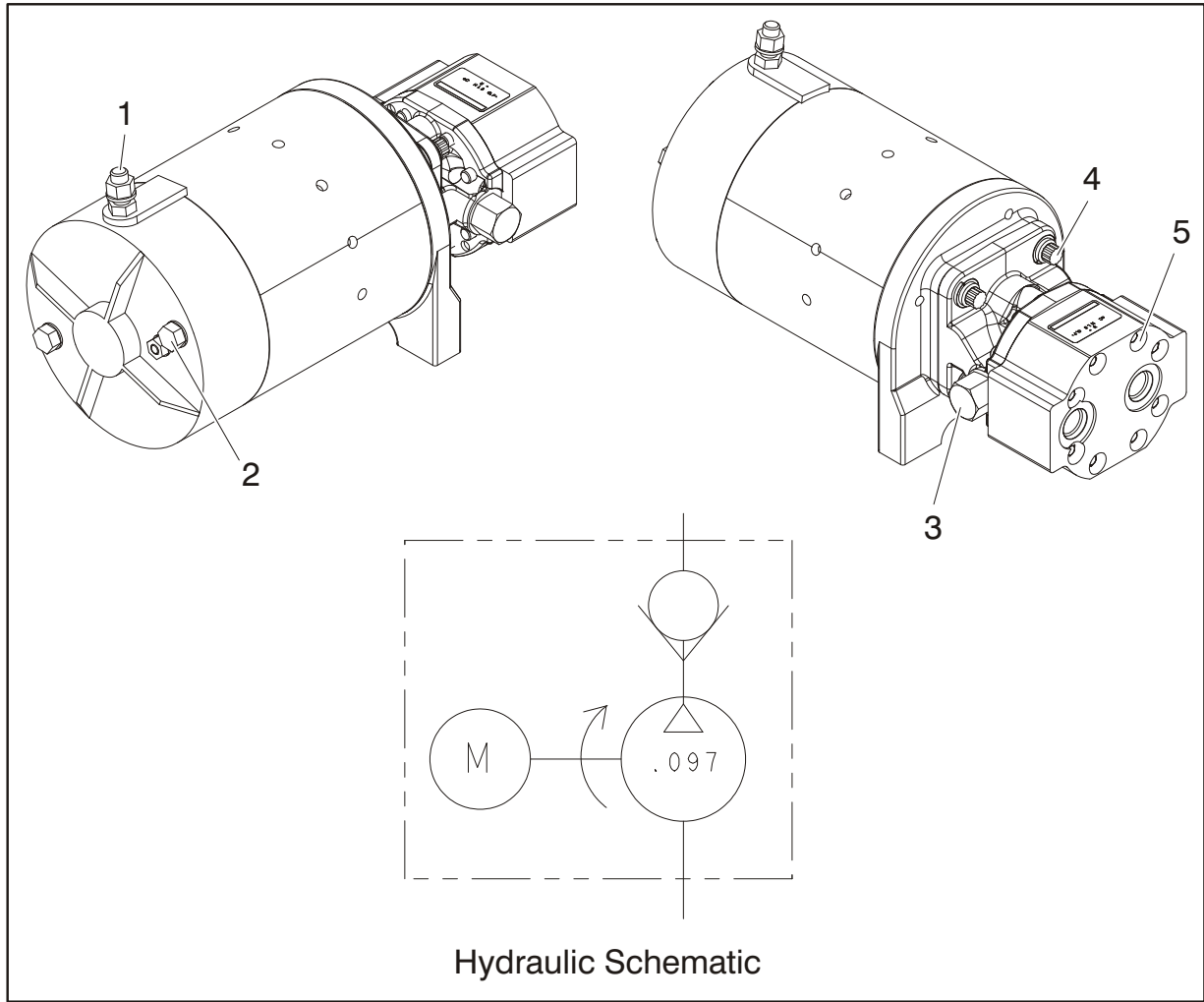

Hydraulic Schematic

Item #	Torque
1. UNF-2A Terminal	84 in-lbs (9.5 Nm)
2. 2x	96 - 120 in-lbs (11 - 14 Nm)
3. Check Valve Cap	144 - 180 in-lbs (16 - 20 Nm)
4. 4x	180 - 216 in-lbs (20 - 24 Nm)
5. 8x	114 - 150 in-lbs (13 - 17 Nm)

Figure 4-27. Auxiliary Pump Motor

- Displacement: 0.097 CU. IN/REV (1.59 CC/REV)

- Delivers 1.2 min. GPM (4.5 min Liters/Min) at 1500 psi (103.4 bar) and 165 Amps maximum at 12VDC

4.13 CYLINDER ASSEMBLIES

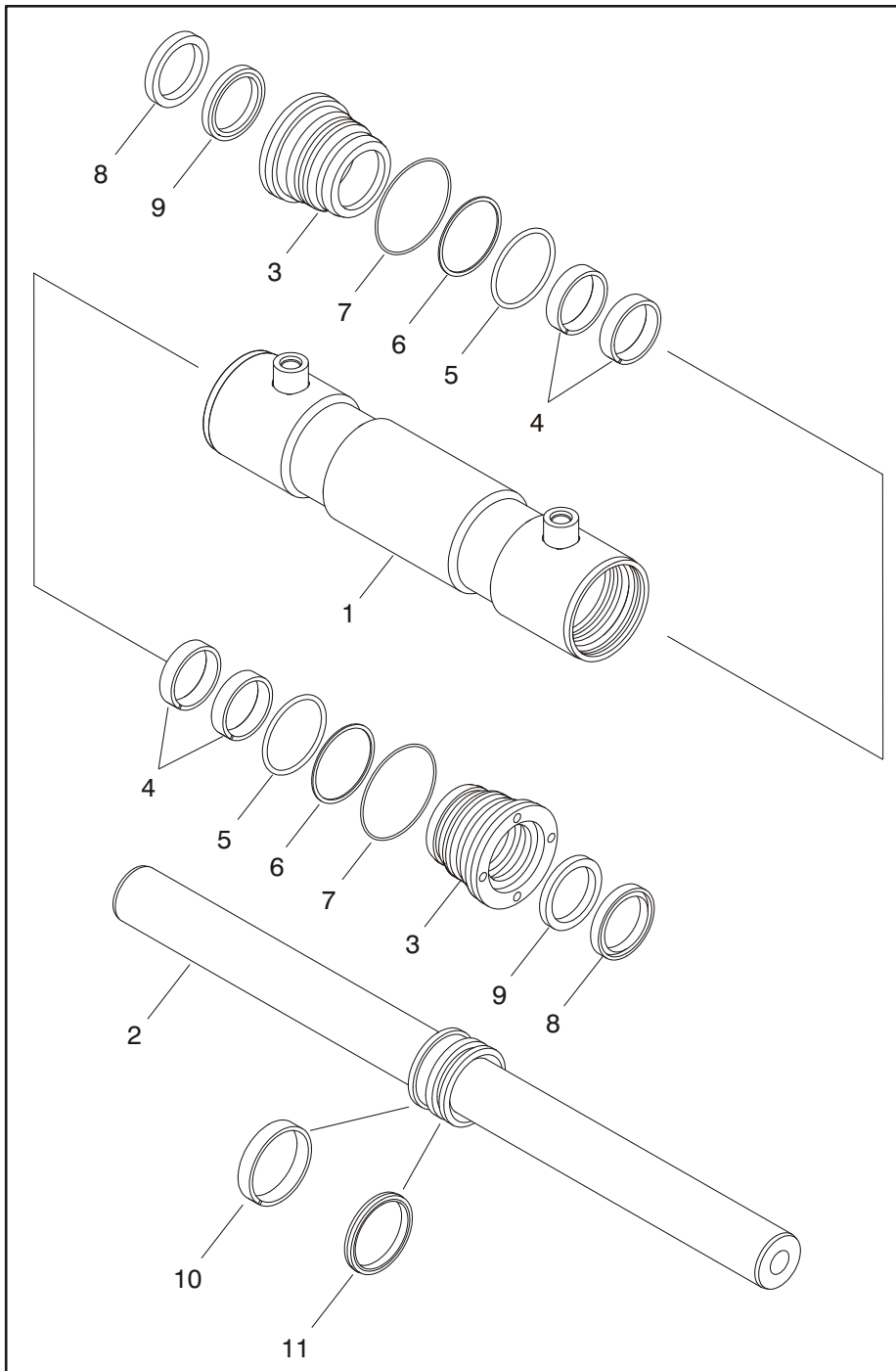

1. Barrel Weldment
2. Rod Weldment
3. Cylinder Head
4. Wear Ring
5. O-ring
6. Back-up Ring
7. O-ring
8. Wiper
9. Seal
10. Wear Ring
11. T-Seal

Figure 4-28. Steer Cylinder

NOTE: Apply ant-seize lube to threads of Cylinder Head (3) and torque to 200 lb-ft (271.2 Nm).

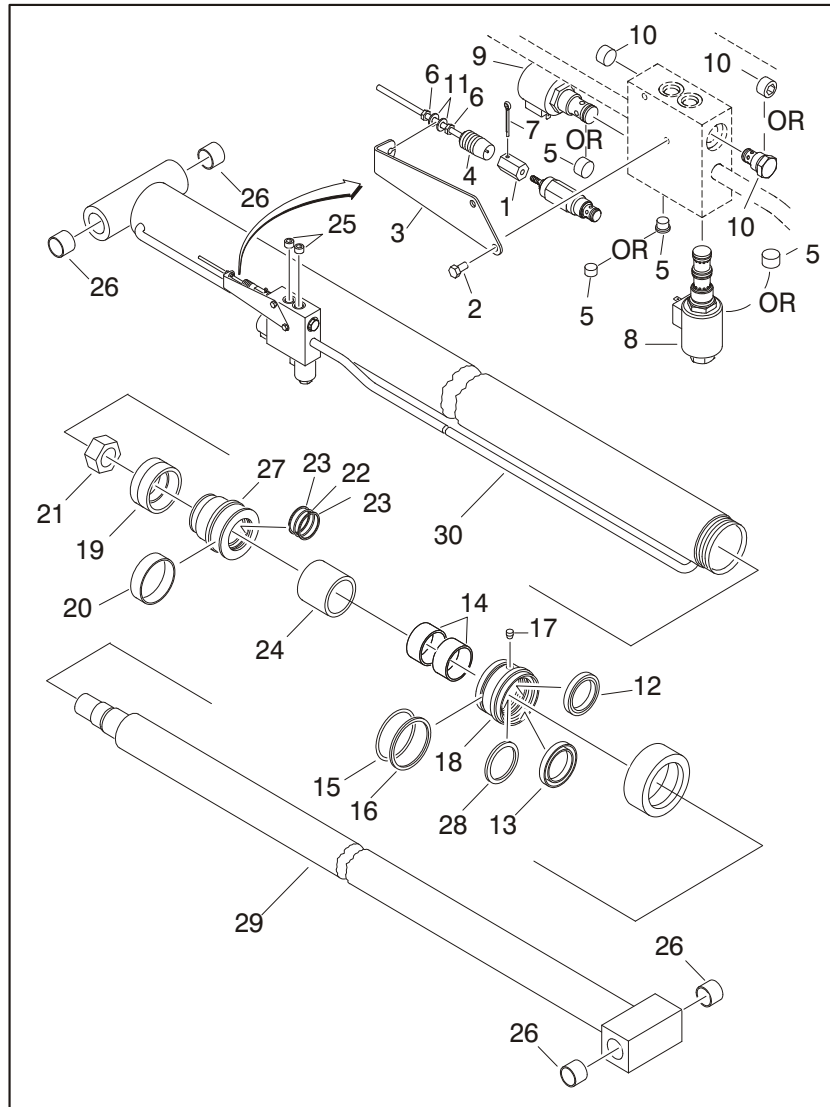

- | | | |
|-------------------------------------|-------------------|--|
| 1. Cable Adapter | 11. Flat Washer | 21. Nut [torque to 475 lb-ft (644 Nm)] |
| 2. Bolt | 12. Wiper | 22. Seal |
| 3. Bracket | 13. Seal | 23. Ring, Back-Up |
| 4. Manual Descent Cable | 14. Ring, Wear | 24. Spacer |
| 5. Plug, O-Ring | 15. Seal | 25. Plug, O-Ring |
| 6. Jam Nut | 16. Ring, Back-Up | 26. Bushing |
| 7. Cotter Pin | 17. Setscrew | 27. Piston |
| 8. Cartridge, Lift Holding Solenoid | 18. Head | 28. Seal |
| 9. Cartridge, Lift Holding Solenoid | 19. Seal | 29. Rod |
| 10. Cartridge, Check | 20. Ring, Wear | 30. Barrel |

Figure 4-29. Lift Cylinder

SECTION 4 - HYDRAULICS

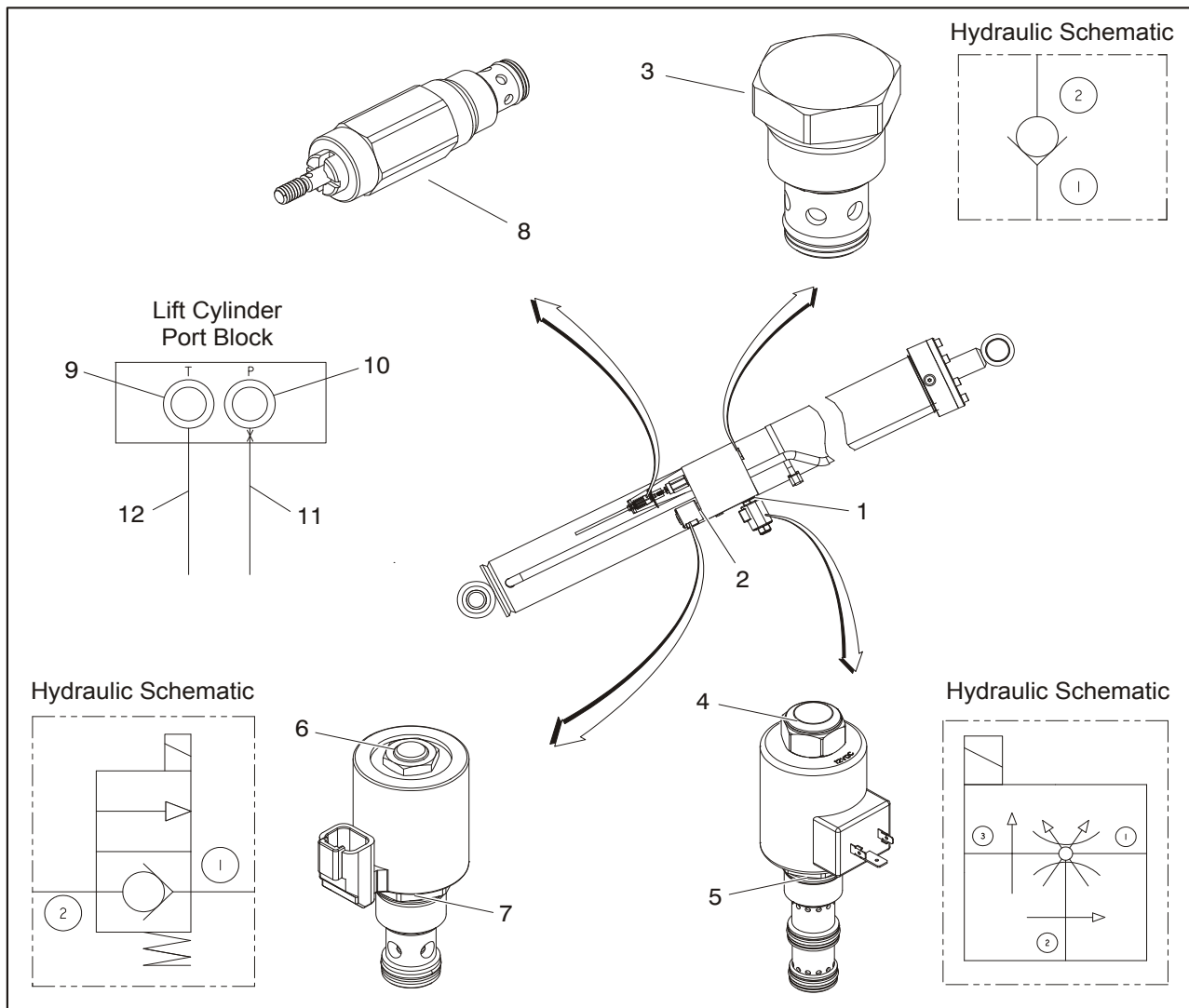

Item	Torque
1	100 lb-ft (135.6 Nm)
2	100lb-ft (135.6 Nm)
3	25 lb-ft (33.9 Nm)
4	10 - 12 lb-ft (13.6 - 16.3 Nm)
5	35 lb-ft (47.5 Nm)
6	5 lb-ft (6.8 Nm)
7	30 lb-ft (40.7 Nm)
8	25 lb-ft (33.9 Nm)
9	40 lb-ft (54.2 Nm)
10	40 lb-ft (54.2 Nm)
11	40 lb-ft (54.2 Nm)
12	60 lb-ft (81.3 Nm)

Figure 4-30. Lift Cylinder Valve Cartridge Torque Values

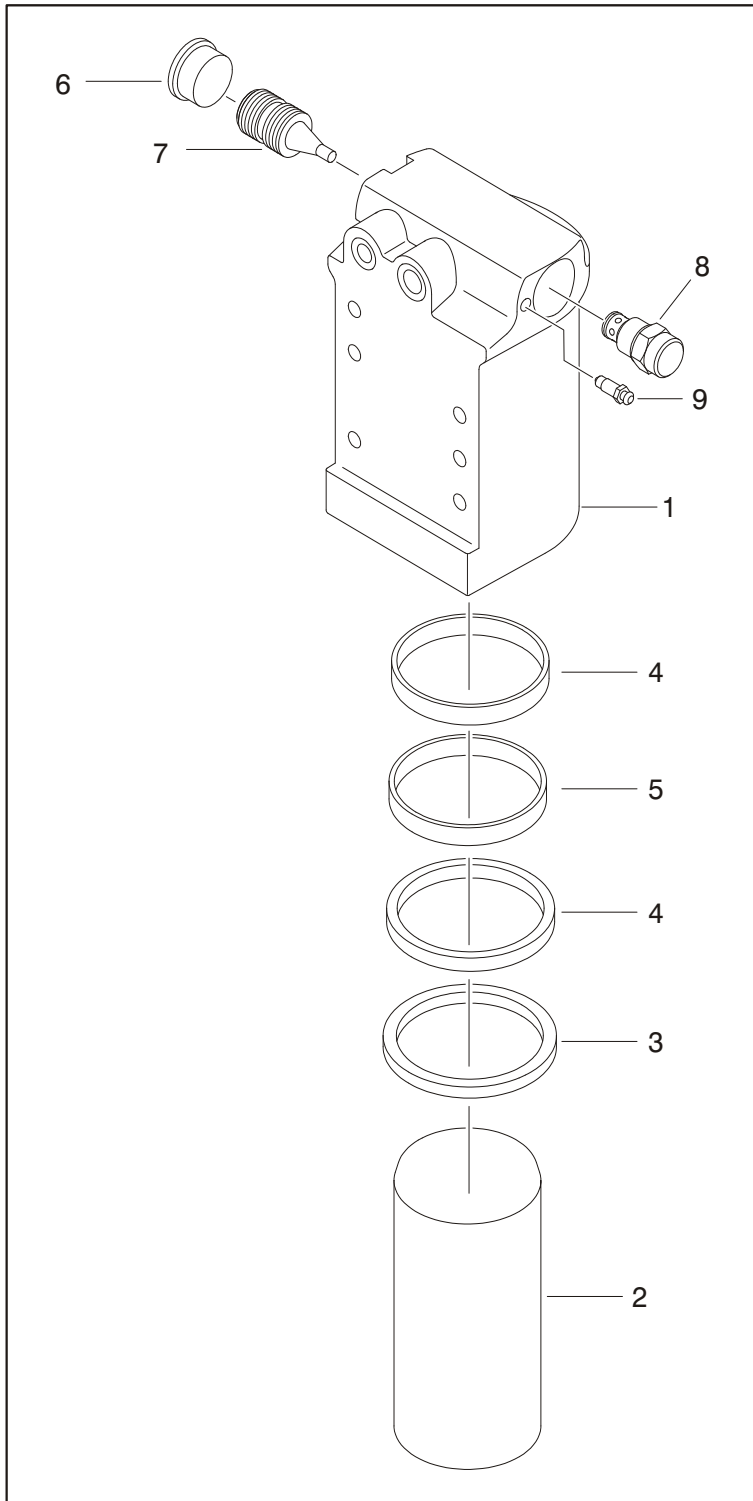

- 1. Barrel
- 2. Rod
- 3. Wiper
- 4. Wear Ring
- 5. Rod Seal
- 6. Plug
- 7. Piston Pilot
- 8. Check Valve
- 9. Bleeder Valve

NOTE: Torque item #8 to 25-27 lb-ft (34-37 Nm)

⚠ WARNING

THE CYLINDER ROD CAN SLIDE OUT OF THE CYLINDER IF THE BLEEDER VALVE IS LOOSE-NED.

Figure 4-31. Oscillating Axle Cylinder

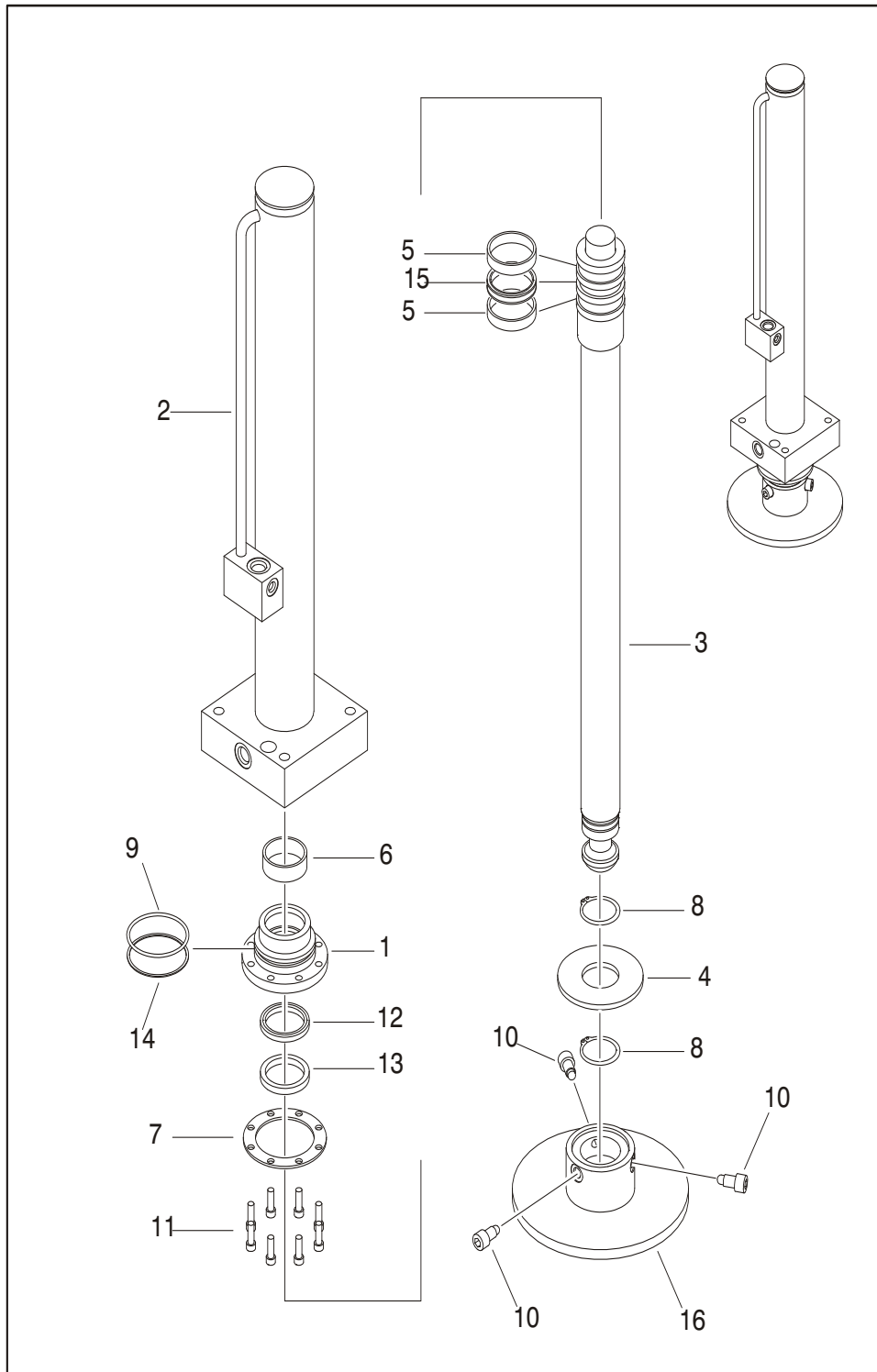

1. Head
2. Barrel
3. Rod
4. Jack Plate
5. Ring, Lock
6. Ring, Wear
7. Ring, Washer
8. Ring, Retaining
9. O-Ring
10. Screw
11. Capscrew
12. Seal
13. Wiper
14. Ring, Back-Up
15. T-Seal
16. Jack Pad

Figure 4-32. Leveling Jack Cylinder

NOTE: Apply a light coat of grease to the Cylinder Rod (3) before installing the Jack Pad (16).
Apply Loctite® #242 to Capscrews (11) and torque to 30 lb-ft (40.7 Nm).

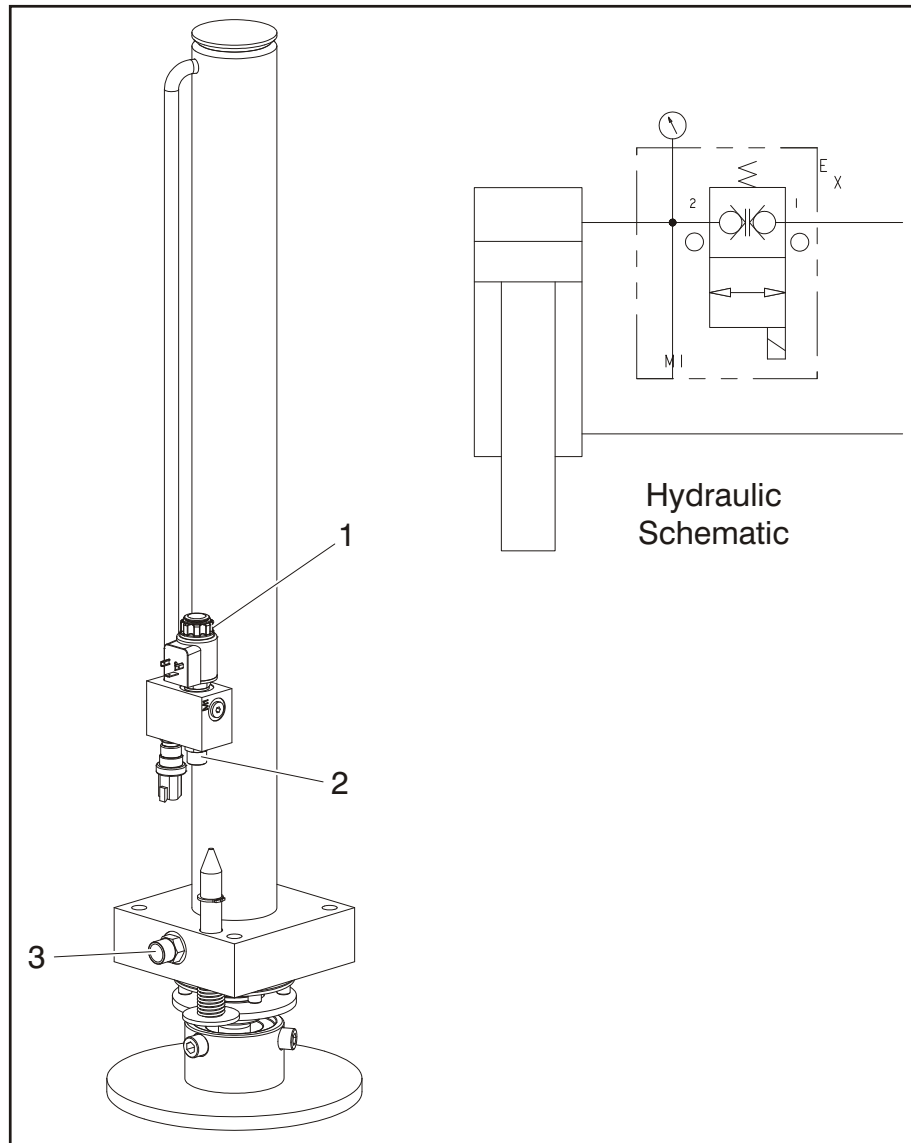

Item	Description	Torque
1	Solenoid Directional Valve	40 lb-ft (54.2 Nm)
2	Straight Fitting	32 lb-ft (43.4 Nm)
3	Straight Fitting	40 lb-ft (54.2 Nm)

Figure 4-33. Leveling Jack Torques

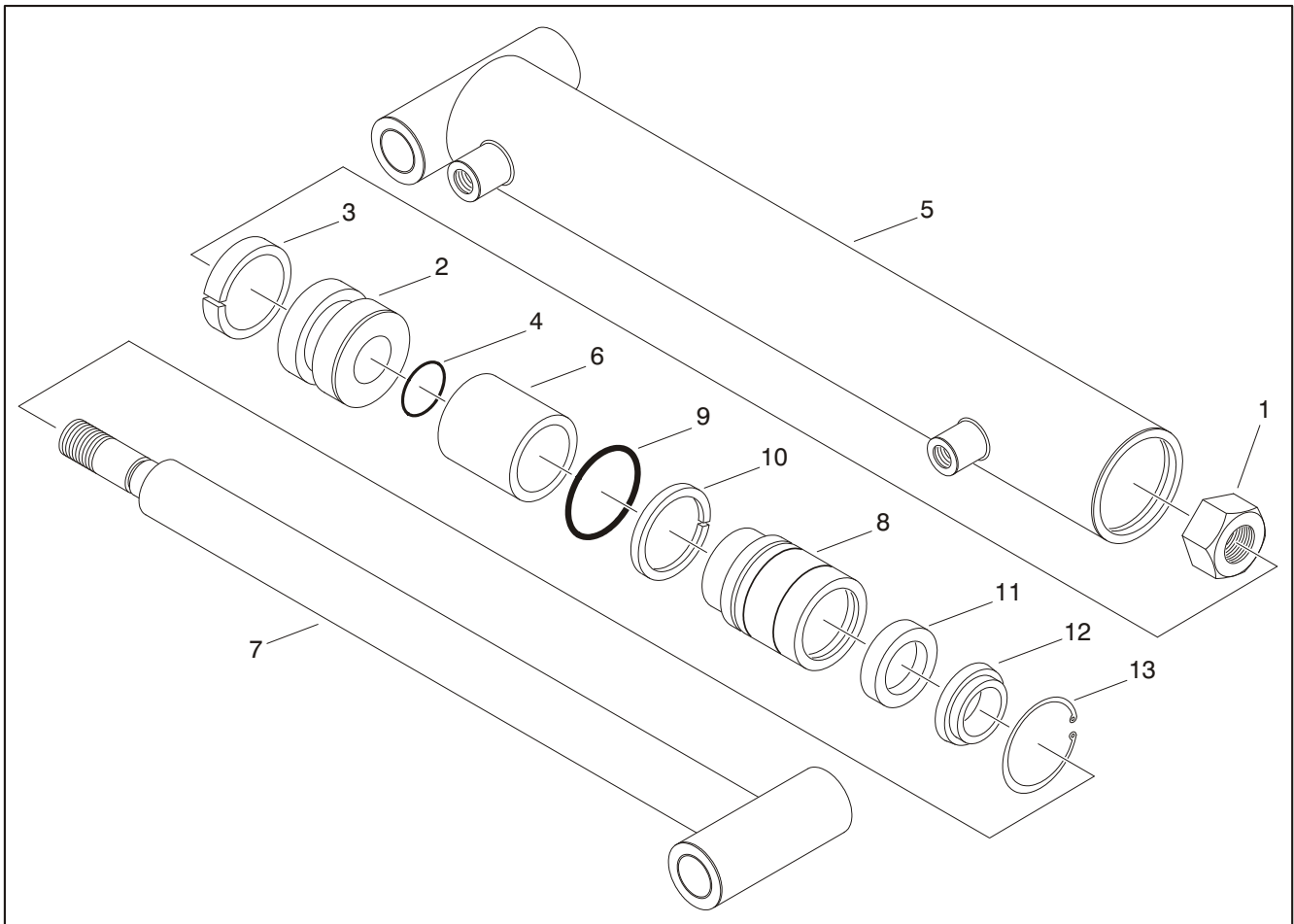

- | | | |
|------------|------------------|--------------------|
| 1. Locknut | 6. Spacer Tube | 11. Seal |
| 2. Piston | 7. Head | 12. Wiper Ring |
| 3. Seal | 8. Rod | 13. Retaining Ring |
| 4. O-Ring | 9. O-Ring | |
| 5. Barrel | 10. Back-up Ring | |

Figure 4-34. Deck Extension Cylinder

Oscillating Axle Cylinder Bleeding Procedure

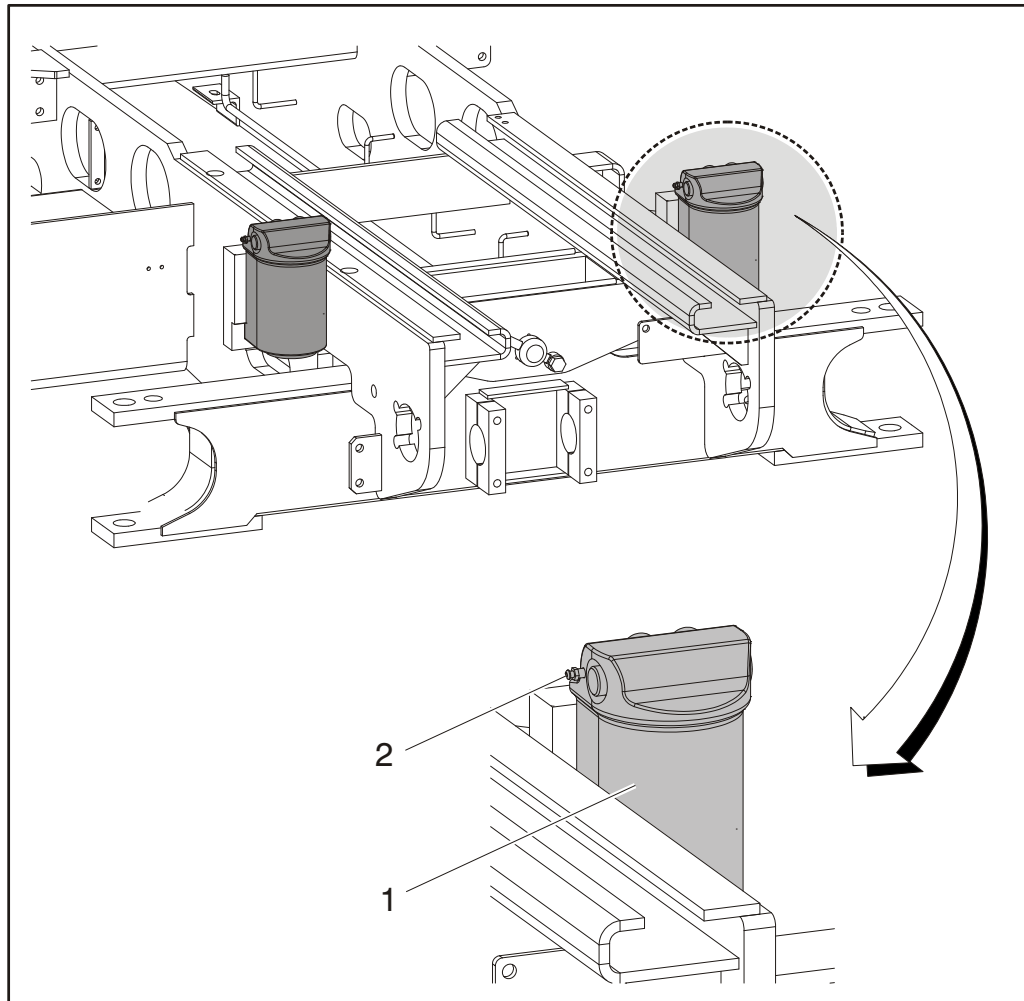

1. Oscillating Axle Cylinder

2. Bleeder Valve

Figure 4-35. Oscillating Axle Cylinder Bleeding

1. Start the engine.
2. Raise the arms high enough so that the left axle cylinder bleeder valve can be accessed.
3. Let engine run at idle.
4. Position a suitable container [approx 0.5 gal (1.9 ltr)] over the bleeder valve.
5. Using a 3/8" wrench, slowly open bleeder valve.
6. Keep the container close enough to the bleeder valve to catch the aerated oil.
7. Open the bleeder valve enough to get a fast stream of oil.

NOTE: A fast stream of oil will exhaust the air out of the hoses and cylinder better than a slow stream of oil.

8. Every 3-4 seconds, close the bleeder valve so that a slower stream of oil is being purged. When only oil and no air is being purged, close the bleeder valve.
9. A new system can take 10-15 seconds per cylinder to bleed.

NOTICE

ANYTIME EITHER OF THE HOSES PLUMBING TO THE CYLINDERS ARE BROKEN INTO, AIR HAS BEEN INTRODUCED INTO THE SYSTEM. THE CYLINDERS MUST BE BLED.

SECTION 5. JLG CONTROL SYSTEM

5.1 HAND HELD ANALYZER

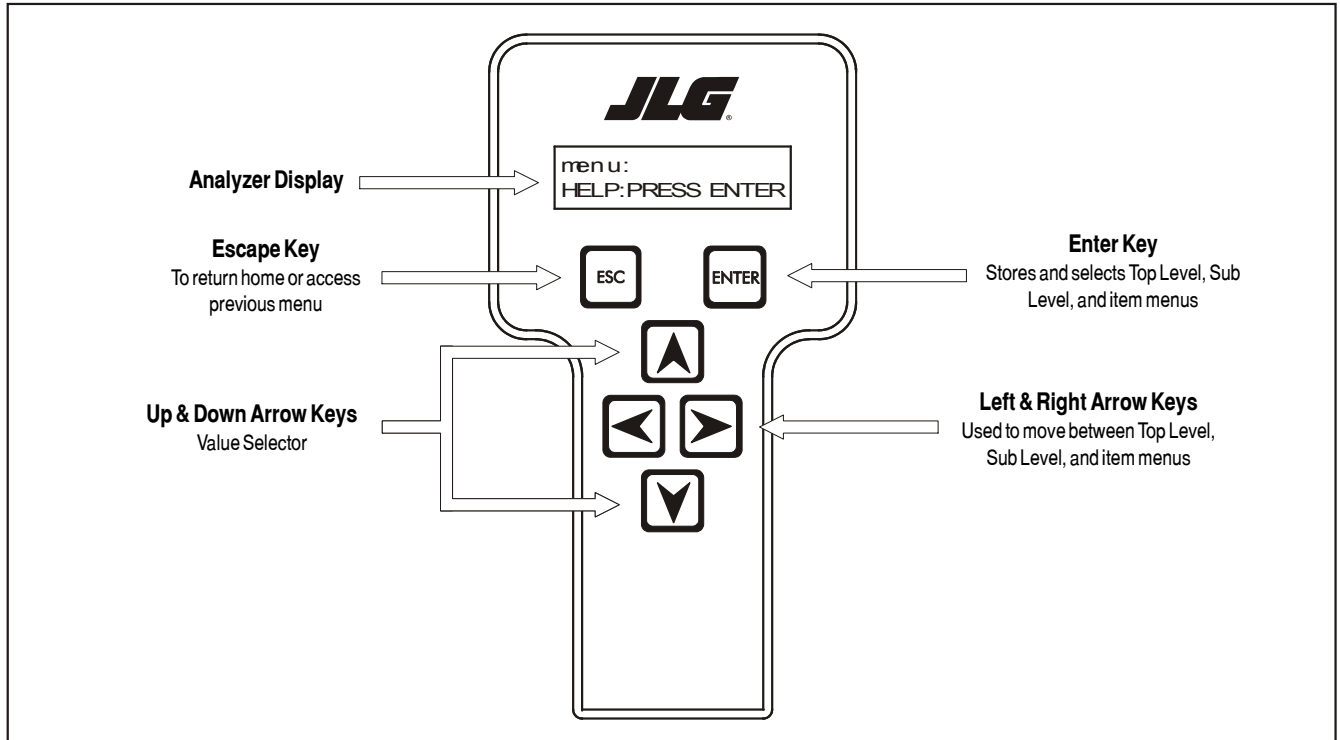

Figure 5-1. Hand Held Analyzer

To Connect the Hand Held Analyzer:

1. Connect the four pin end of the cable supplied with the analyzer, to the four position connector on the

PCB in the ground control station or at the platform control station as shown in. Connect the remaining end of the cable to the analyzer.

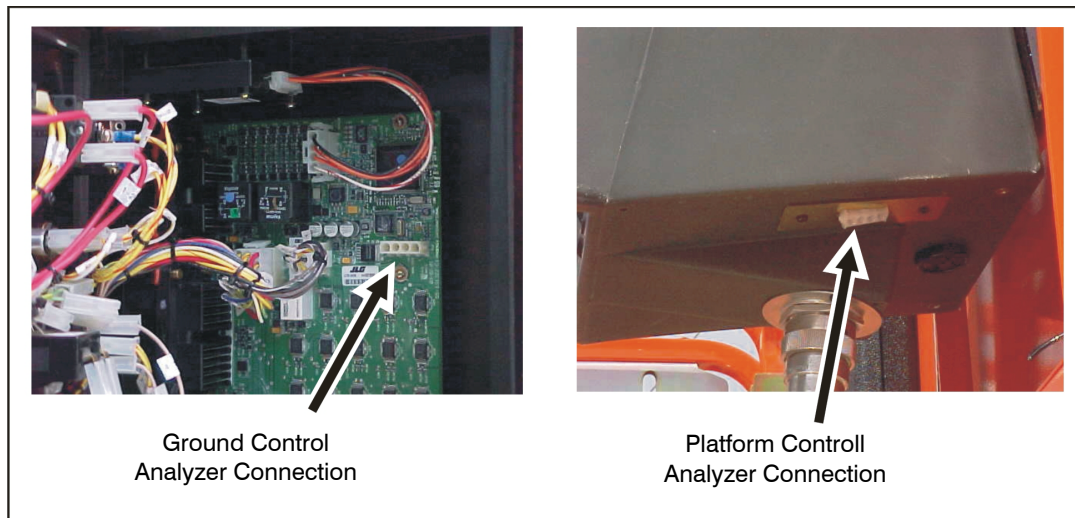

Figure 5-2. Analyzer Connection

SECTION 5 - JLG CONTROL SYSTEM

NOTE: The cable has a four pin connector at each end; the cable cannot be connected backwards.

2. Power up the Control System by turning the lower key to the platform position and pulling out both emergency stop buttons.

Using the Analyzer:

With the machine power on and the analyzer connected properly, the analyzer will display the following:

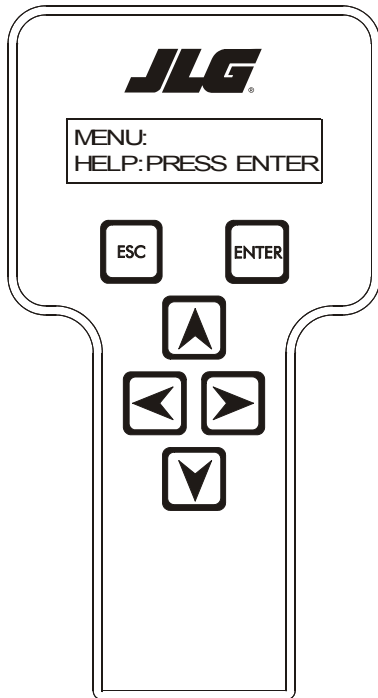

**HELP:
PRESS ENTER**

At this point, using the **RIGHT** and **LEFT** arrow keys, you can move between the top level menu items. To select a displayed menu item, press **ENTER**. To cancel a selected menu item, press **ESC**; then you will be able to scroll using the right and left arrow keys to select a different menu item.

The top level menus are as follows:

**HELP
DIAGNOSTICS
ACCESS LEVEL
PERSONALITIES
MACHINE SETUP
ACTIVATE TESTS
CALIBRATION**

If you press **ENTER**, at the HELP:PRESS ENTER display, and a fault is present during power up, the analyzer dis-

play will scroll the fault across the screen. If there was no fault detected during power up, the display will read: In platform mode, **HELP: EVERYTHING OK**, In ground mode, **GROUND MODE OK**

If **ENTER** is pressed again, the display moves to the following display:

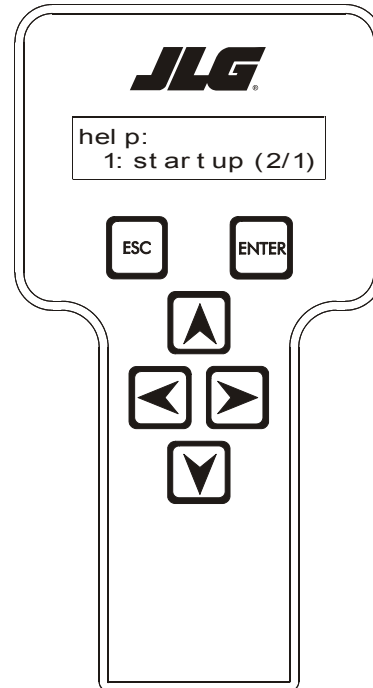

LOGGED HELP

1: STARTUP (2/1): (Or last recorded fault)

At this point, the analyzer will display the current fault, if any are present. You may scroll through the fault logs to view what the last fifteen faults were. Use the right and left arrow keys to scroll through the fault logs. To return to the beginning, press **ESC** two times.

When a top level menu is selected, a new set of menu items may be offered; If for example you choose Personalities:

**DRIVE
LIFT
STEER
GROUND**

Pressing **ENTER** with any of the above displayed menus will display additional sub-menus within the selected menu. In some cases the next level is the parameter or information to be changed. Refer to the flow chart for what menus are available within the top level menus. You may only view the personality settings for selected menus while in access level 2. Remember, you may always cancel a selected menu item by pressing the **ESC** key.

Changing the Access Level of the Hand Held Analyzer:

When the analyzer is first connected, you will be in access level 2 which enables you to only view most configuration settings which cannot be changed until you enter a password to advance to a lower level. This ensures that a setting cannot be accidentally altered. To change the access level, the correct password must be entered. To enter the password, scroll to the **ACCESS LEVEL** menu. For example:

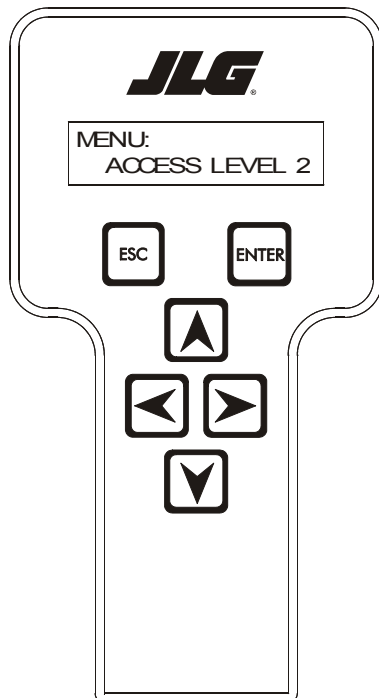

MENU:
ACCESS LEVEL 2

Press **ENTER** to select the **ACCESS LEVEL** menu.

Using the **UP** or **DOWN** arrow keys, enter the first digit of the password, 3.

Then using the **RIGHT** arrow key, position the cursor to the right one space to enter the second digit of the password.

Use the **UP** or **DOWN** arrow key to enter the second digit of the password which is 3.

Repeat this process until you have entered all five digits of the password which is **33271**.

Once the correct password is displayed, press **ENTER**. The access level should display the following, if the password was entered correctly:

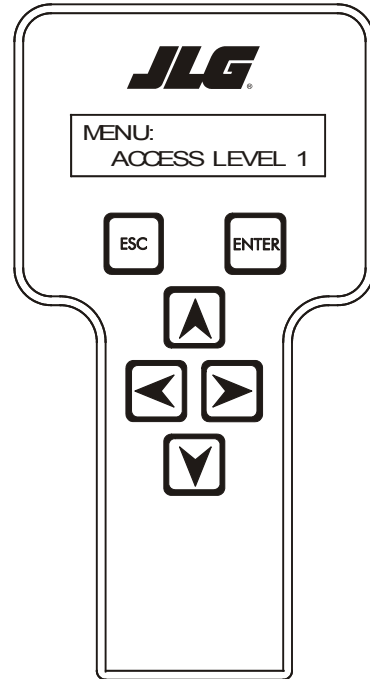

MENU:
ACCESS LEVEL 1

Repeat the above steps if the correct access level is not displayed or you can not adjust the personality settings.

Adjusting Parameters Using the Hand Held Analyzer

Once you have gained access to level 1, and a personality item is selected, press the UP or DOWN arrow keys to adjust its value, for example:

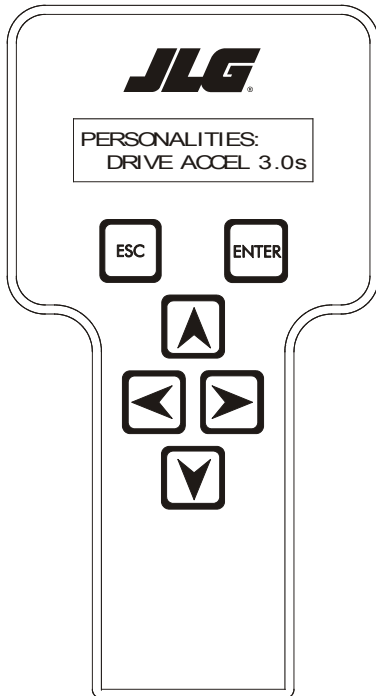

**PERSONALITIES:
DRIVE ACCEL 3.0s**

There will be a minimum and maximum for the value to ensure efficient operation. The value will not increase if the **UP** arrow is pressed when at the maximum value nor will the value decrease if the **DOWN** arrow is pressed and the value is at the minimum value for any particular personality. If the value does not change when pressing the up and down arrows, check the access level to ensure you are at access level 1.

Machine Setup

When a machine digit item is selected, press the **UP** or **DOWN** arrow keys to adjust its value, for example:

⚠ WARNING

FAILURE TO MAKE THE PROPER SETTINGS FOR THE PARTICULAR MACHINE CAN RESULT IN IMPROPER OPERATION.

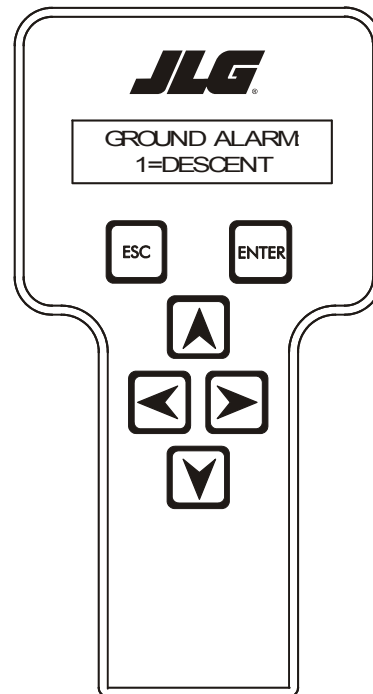

**GROUND ALARM:
1=DESCENT**

The effect of the machine digit value is displayed along with its value. The above display would be selected if the machine was equipped with a ground alarm and you wanted it to sound when driving. There are certain settings allowed to install optional features or select the machine model.

When selecting the machine model to match the size of the machine, the personality settings will return to default settings.

NOTE: Refer to Table 5-3, Machine Configuration Programming Information and Table 5-5, Machine Model Adjustment for default settings.

Password 33271 will give you access to level 1, which will permit you to change all machine personalities and/or machine setup settings.

⚠ WARNING

CHANGING THESE SETTINGS MAY ADVERSELY AFFECT THE PERFORMANCE OF YOUR MACHINE.

The flash code is indicated on the face of the platform control box as shown:

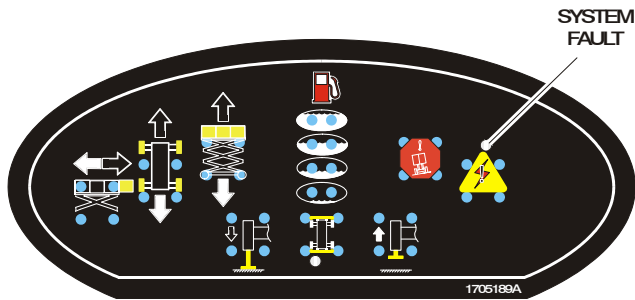

NOTE: Flash codes are also displayed on the handheld analyzer. For descriptions see Table 5-1, Fault Code Listing.

NOTICE

IT IS A GOOD PRACTICE TO AVOID PRESSURE-WASHING ELECTRICAL/ELECTRONIC COMPONENTS. SHOULD PRESSURE-WASHING BE UTILIZED TO WASH AREAS CONTAINING ELECTRICAL/ELECTRONIC COMPONENTS, JLG INDUSTRIES, INC. RECOMMENDS A MAXIMUM PRESSURE OF 750 PSI (52 BAR) AT A MINIMUM DISTANCE OF 12 INCHES (30.5 CM) AWAY FROM THESE COMPONENTS. IF ELECTRICAL/ELECTRONIC COMPONENTS ARE SPRAYED, SPRAYING MUST NOT BE DIRECT AND BE FOR BRIEF TIME PERIODS TO AVOID HEAVY SATURATION.

5.2 CALIBRATIONS

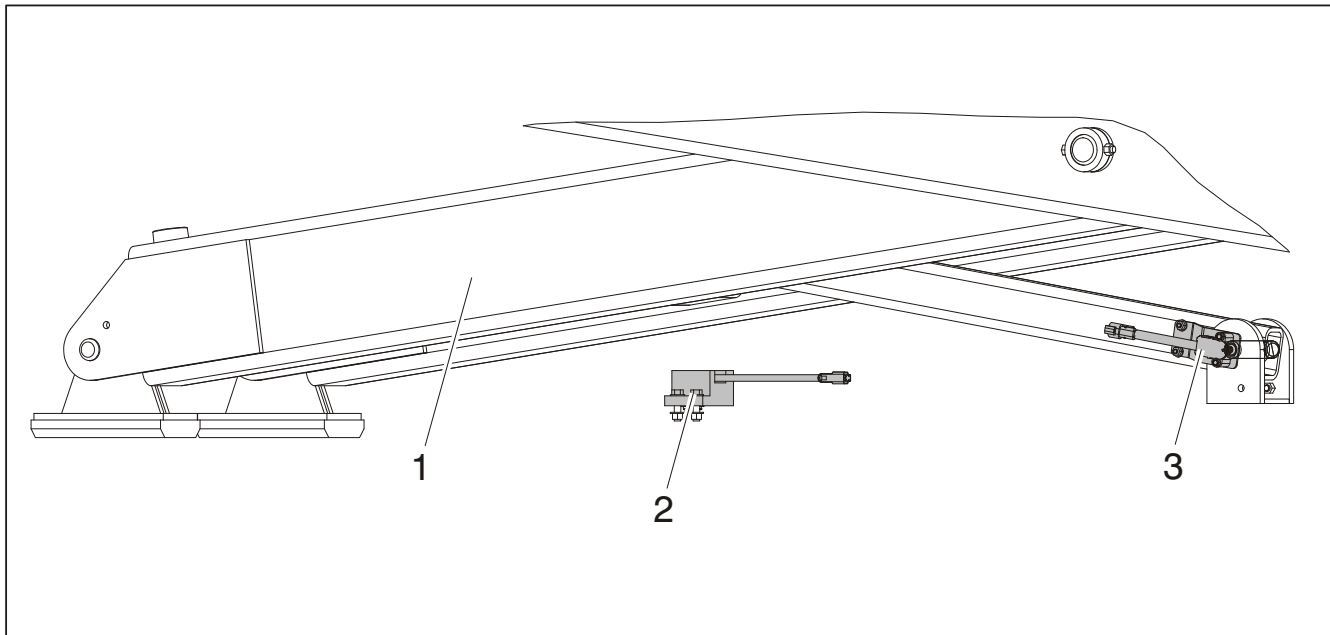

- 1. Scissor Arm Assembly
- 2. Proximity Sensor
(on frame inboard slide channel)
- 3. Rotary Angle Sensor

Figure 5-3. Limit Switch Location

Elevation Sensor Calibration

Using the Analyzer, in Access Level 1, go to MENU: CALIBRATION:

1. SET STOW ELEV;
 - a. Completely lower platform to stowed position.
 - b. Enter YES on the Analyzer.
 - c. COMPLETE will show on the analyzer when calibrated.
2. SET 26FT ELEV (3394RT) or SET 30FT ELEV (4394RT);
 - a. Raise platform to a height of 26 feet for the 3394RT or 30 feet for the 4394RT (measured deck to ground).
 - b. Enter YES on the Analyzer.
 - c. COMPLETE will show on the analyzer when calibrated.

3. SET 30FT ELEV (3394RT) or SET 36FT ELEV (4394RT);
 - a. Raise platform to a height of 30 feet on the 3394RT or 36 feet for the 4394RT (measured deck to ground).
 - b. Enter YES on the Analyzer.
 - c. COMPLETE will display on the analyzer when calibrated.

NOTE: Elevation Proximity Switch must be mounted and functioning properly to calibrate the Elevation Sensor.

NOTICE

FOR MACHINE TO OPERATE TO CAPACITY, BE SURE TO CALIBRATE ELEVATION SENSOR AT ALL THREE POSITIONS.

Joystick Calibration

Using the Analyzer, in Access Level 1, go to MENU: CALIBRATION: JOYSTICK and press ENTER.

1. Following the analyzer screen prompts:
 - a. Move the Joystick FORWARD and press ENTER.
 - b. Allow Joystick to be in CENTER position and press ENTER.
 - c. Move the Joystick REVERSE and press ENTER.
2. CAL COMPLETE or CAL FAILED will display on the analyzer.
3. Possible reasons if calibration failure:
 - a. The forward position must be a lower voltage than reverse position.
 - b. The difference between center and forward & center and reverse must be at least 1V.

Tilt Sensor Calibration:

1. Drive the machine onto a measured level surface ($\pm 0.5^\circ$ for both x and y axis).
2. Using the Analyzer, go to MENU: CALIBRATION; TILT SENSOR. Press Enter. LEVEL VEHICLE will display. Press Enter again to calibrate.
3. Both axis' raw angles need to be within $\pm 5.0^\circ$, otherwise the machine is too unlevel and the software will prohibit calibration. Should this occur, attempt to dissect the three areas of error to find the primary contributor:
 - a. Machine mounting and/or grade:

With a digital level, measure the top of the Ground Control box for levelness. If unable to get a good reading, check the box's mounting surface for levelness.

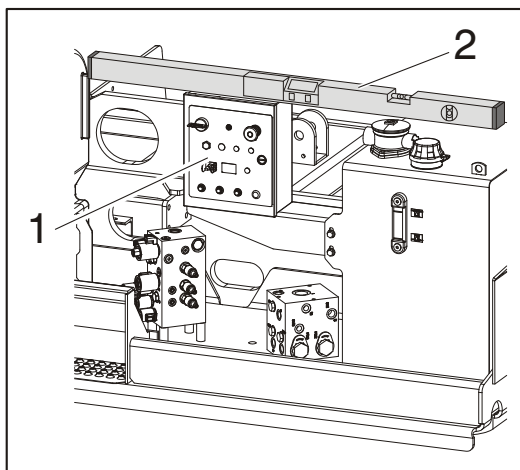

1. Ground Control Box 2. Digital Level

- b. Tilt sensor mounting on machine or wedged crooked in control box:

If the machine mounting/grade appears acceptable, open the Ground Control box carefully. Observe whether the tilt sensor is properly seated.

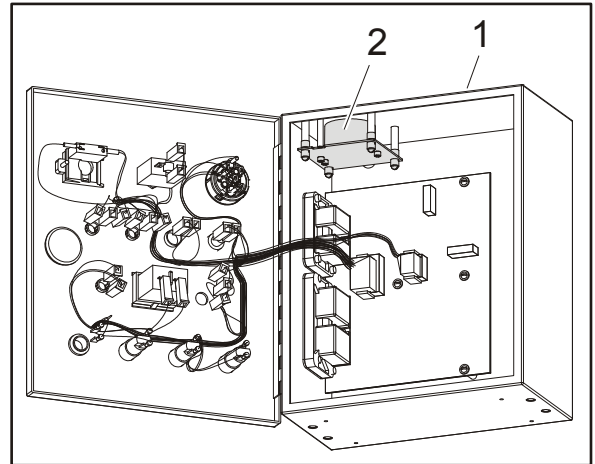

1. Ground Control Box 2. Tilt Sensor

- c. Tilt sensor has developed an offset shift:

Remove the tilt sensor from the Ground Control box, but keep both the tilt sensor and Ground Control box electrically connected. Level one axis of the tilt sensor and observe the raw reading (should be within $\pm 2.0^\circ$). Do the same for the other axis. If either axis is greater than $\pm 2.0^\circ$, replace the tilt sensor.

Some possible reasons that the tilt sensor will not calibrate are:

- a. The surface the machine is sitting on is off level by a few degrees (flat doesn't imply level; parking lots are often not level).
- b. The tilt sensor has failed one or both of the channels (X axis and Y axis).
- c. Tilt sensor has moisture intrusion that has shifted its output.
- d. Water and/or corrosion in the box has corrupted electrical connections or caused a tilt sensor or ground control board failure (observe any cracks in the box).
- e. The Ground Control Box, as mounted on the machine, does not allow the tilt sensor to be level.

For the following troubleshooting steps, a bubble level (smaller is better) will be needed and the machine must be on a level surface:

1. On the Analyzer, go to Diagnostics/System and read the tilt angle. If either angle reports $+20.0^\circ$, there is

SECTION 5 - JLG CONTROL SYSTEM

an electrical/electronic failure (tilt sensor, control board, electrical connections).

- a. Open the Ground Control Box.
 - b. Disconnect the sensor and clean any corrosion off of the tilt sensor and control board connections.
 - c. Reassemble and test. If fault persists, replace tilt sensor.
2. If the Analyzer displays angles other than +20.0°, attempt to calibrate. If machine will not calibrate, note the reason displayed on Analyzer:
 - a. SENSOR FAILURE – tilt sensor internal frequency is out of range (replace sensor).
 - b. NOT LEVEL - tilt sensor has either developed an offset or it is too unlevel as mounted on the machine.

Tilt Sensor

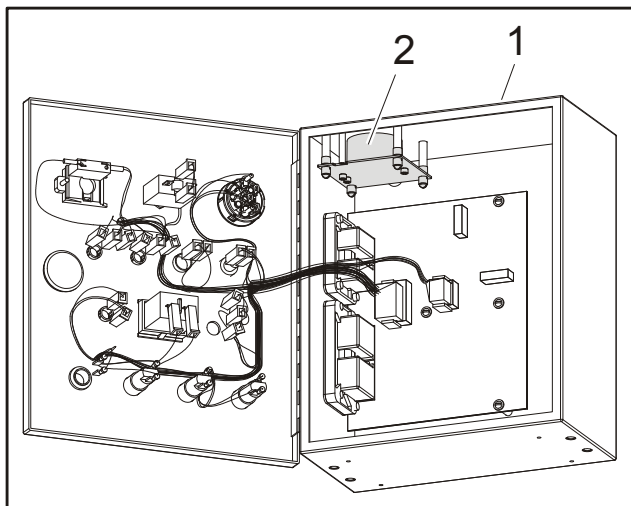

1. Ground Control Box
2. Tilt Sensor Assembly (JLG P/N 1810140)

Figure 5-4. Tilt Sensor Location

NOTE: Refer to Figure 5-5., Tilt Sensor Removal for numbers in parenthesis.

1. Disconnect the batteries.
2. Open the Ground Control Box to gain access to the Tilt Sensor Assembly.
3. Remove the four Screws (3), Lockwashers (4), Standoff Insulators (5), and Washers (6) to remove the Tilt Sensor (1) and Sensor Mount (2) from the Ground Control Box.

4. The Tilt Sensor (1) can be removed from the Sensor Mount (2) by removing the three Screws (7).

NOTE: Follow the above procedures in reverse order when installing the tilt sensor assembly. After installing, be sure to calibrate the tilt sensor (refer to Section 5.2, Calibrations).

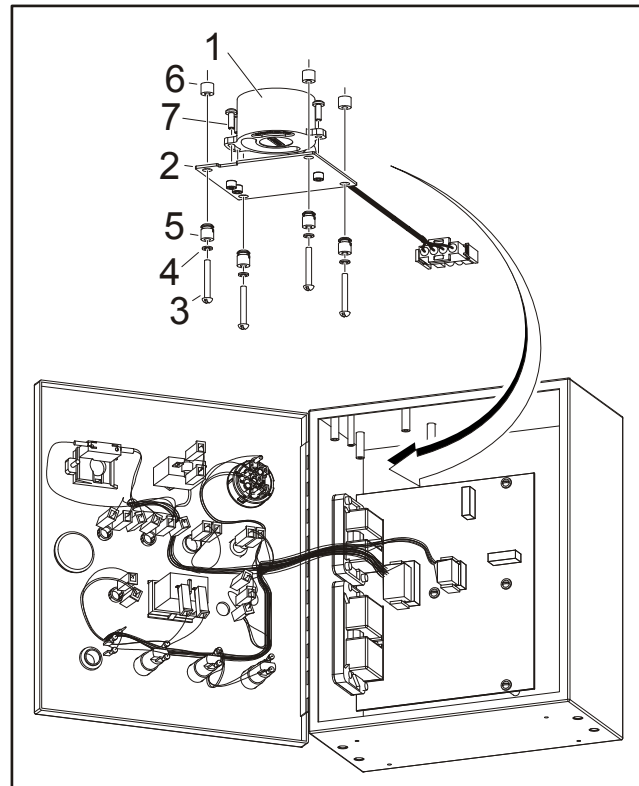

1. Tilt Sensor (JLG P/N 4000021)
2. Sensor Mount
3. Screw, 6-32 x 1
4. Lockwasher
5. Standoff Insulator
6. Washer, 0.313 x 0.250 Nylon
7. Screw, M3.5 x 0.6 x 10

Figure 5-5. Tilt Sensor Removal

Table 5-1. Tilt Sensor Harness

Wire Color	Function	Connector Pin
Red	VCC	1
Green	PWMX	2
White	PWMY	3
Black	Ground	4

5.3 FLASH CODES AND DESCRIPTIONS

Table 5-2. Fault Code Listing - Software P1.X

Fault Flash Code	Communicated (Displayed on Analyzer) Fault	Description	Priority
None		No flash code is indicated for the following help messages. They are intended to hint at a possible problem if the vehicle is not behaving as expected.	1
	FUNCTION SELECTED BUT TRIGGER SWITCH OPEN	Reported when the trigger is not closed with function selected and joystick out of center.	
	RUNNING AT CUTBACK – ABOVE ELEVATION	Reported any time the machine is considered to be above elevation.	
	ACCESSORY FAULT	Reports when CAN faults are reported by an accessory module.	
	FRONT LEFT LEVELING JACK AT END OF STROKE	Reported when the front left leveling jack is reported to be at the end of stroke pressure.	
	FRONT RIGHT LEVELING JACK AT END OF STROKE	Reported when the front right leveling jack is reported to be at the end of stroke pressure.	
	REAR LEFT LEVELING JACK AT END OF STROKE	Reported when the rear left leveling jack is reported to be at the end of stroke pressure.	
	REAR RIGHT LEVELING JACK AT END OF STROKE	Reported when the rear right leveling jack is reported to be at the end of stroke pressure.	
	LEVELING JACK SET PREVENTED - ECM LOST	Reported when autoleveling is not available when communication with the ECM times-out.	
	GENERATOR PREVENTED - ECM LOST	Reported when generator is not available when communication with the ECM times-out.	
	DRIVE PREVENTED - ECM LOST	Reported when elevated drive is not available when communication with the ECM times-out.	
	ELEVATION SENSOR DISAGREEMENT	Reported when elevation prox switch is closed when the 26 ft (3394RT) or 30 ft (4394RT) voltage is reached on the elevation angle sensor. (prevents further lift up from platform controls)	
2/1		Flash code 2/1 indicates issues at power up.	2
	KEYSWITCH FAULTY – PLATFORM & GROUND ACTIVE TOGETHER	Reported when the ground module is reading both ground and platform modes are selected by the keyswitch. The control system defaults control to ground mode.	

SECTION 5 - JLG CONTROL SYSTEM

Table 5-2. Fault Code Listing - Software P1.X

Fault Flash Code	Communicated (Displayed on Analyzer) Fault	Description	Priority
		Flash code 2/2 indicates difficulty with the platform controls.	
	TRIGGER SWITCH WIRING SHORTED HIGH IN PLATFORM CABLE	Reports when the CAN message coming from the platform board and the DI on ground board conflict.	
	TRIGGER SWITCH WIRING SHORTED LOW IN PLATFORM CABLE	Reports when the CAN message coming from the platform board and the DI on ground board conflict.	
	FUNCTION LOCKED OUT – DRIVE SELECT PERMANENTLY CLOSED	Reported when drive select is closed during power up.	
	FUNCTION LOCKED OUT – LIFT SELECT PERMANENTLY CLOSED	Reported when lift select is closed during power up.	
	FUNCTION LOCKED OUT – FRONT DECK SELECT PERMANENTLY CLOSED	Reported when front deck select is closed during power up.	
	FUNCTION LOCKED OUT – REAR DECK SELECT PERMANENTLY CLOSED	Reported when rear deck select is closed during power up.	
	FUNCTION LOCKED OUT – START PERMANENTLY CLOSED	Reported when the start switch is closed during power up.	
	FUNCTION LOCKED OUT – STEER LEFT PERMANENTLY CLOSED	Reported when the left steer switch is closed during power up.	
2/2	FUNCTION LOCKED OUT – STEER RIGHT PERMANENTLY CLOSED	Reported when the right steer switch is closed during power up.	3
	FUNCTION LOCKED OUT – AUX POWER SWITCH PERMANENTLY CLOSED	Reported when the auxiliary switch is closed during power up.	
	FUNCTION LOCKED OUT – GENERATOR SWITCH PERMANENTLY CLOSED	Reported when the generator switch is closed during power up.	
	FUNCTION LOCKED OUT – AUTOLEVEL SWITCH PERMANENTLY CLOSED	Reported when the leveling jack select switch is closed during power up.	
	TRIGGER CLOSED TOO LONG WHILE IN NEUTRAL	Reported when trigger is closed for ten seconds and no function selected.	
	FUNCTION LOCKED OUT – JOYSTICK NOT CENTERED	Reported when joystick is not centered while selecting a function.	
	FUNCTION LOCKED OUT – TRIGGER SWITCH PERMANENTLY CLOSED	Reported when the trigger switch is closed during power up.	
	JOYSTICK FAULTY – STEER SWITCHES ACTIVE TOGETHER	Reported when both the left and right steer switches are closed at the same time.	
	FUNCTION LOCKED OUT – HORN SWITCH PERMANENTLY CLOSED	Reported when the horn switch is closed during power up.	
	JOYSTICK CALIBRATION FAULTY	Reported when joystick calibration is improper. (Platform P1.6 or later only)	

Table 5-2. Fault Code Listing - Software P1.X

Fault Flash Code	Communicated (Displayed on Analyzer) Fault	Description	Priority
2/3		Flash code 2/3 indicates difficulty with ground controls.	4
	FUNCTION LOCKED OUT – GROUND LIFT UP PERMANENTLY CLOSED	Reported when the ground lift up switch is closed during power up.	
	FUNCTION LOCKED OUT – GROUND LIFT DOWN PERMANENTLY CLOSED	Reported when the ground lift down switch is closed during power up.	
	FUNCTION LOCKED OUT – GROUND FRONT DECK EXT PERMANENTLY CLOSED	Reported when the ground front deck extend switch is closed during power up.	
	FUNCTION LOCKED OUT – GROUND FRONT DECK RET PERMANENTLY CLOSED	Reported when the ground front deck retract switch is closed during power up.	
	FUNCTION LOCKED OUT – GROUND REAR DECK EXT PERMANENTLY CLOSED	Reported when the ground rear deck extend switch is closed during power up.	
	FUNCTION LOCKED OUT – GROUND REAR DECK RET PERMANENTLY CLOSED	Reported when the ground rear deck retract switch is closed during power up.	
	GROUND LIFT UP/DOWN ACTIVE TOGETHER	Reported when the ground lift up and lift down switches are closed at the same time.	
	GROUND FRONT DECK EXTEND/RETRACT ACTIVE TOGETHER	Reported when the ground front deck extend and retract switches are closed at the same time.	
	GROUND REAR DECK EXTEND/RETRACT ACTIVE TOGETHER	Reported when the ground rear deck extend and retract switches are closed at the same time.	
	NO SIGNAL FROM TILT SENSOR X AXIS – CHECK WIRING	Reported when sensor X-axis value is not valid.	
	NO SIGNAL FROM TILT SENSOR Y AXIS – CHECK WIRING	Reported when sensor Y-axis value is not valid.	
	LEVEL SENSOR FAILURE	Reported when the tilt sensor frequency is outside the range of acceptable value.	
FUNCTION LOCKED OUT – GROUND AUX SWITCH PERMANENTLY CLOSED	Reported when the ground auxiliary power switch is closed during power up.		
FUNCTION LOCKED OUT – GROUND START SWITCH PERMANENTLY CLOSED	Reported when the ground start switch is closed during power up.		

SECTION 5 - JLG CONTROL SYSTEM

Table 5-2. Fault Code Listing - Software P1.X

Fault Flash Code	Communicated (Displayed on Analyzer) Fault	Description	Priority
		Flash code 2/5 indicates issues that may cutout functions.	
	ELEV ANGLE SENSOR FAULTY – NOT MOUNTED OR VOLTAGE OUT OF RANGE	Reported when the elevation rotary sensor voltage is outside the range of acceptable values.	
	ELEV ANGLE SENSOR HAS NOT BEEN CALIBRATED	Reported when the rotary calibration value does not exist.	
	ELEVATION PROX SWITCH PERMANENTLY CLOSED	Reported when the elevation rotary sensor is reporting above elevation and the elevation proximity switch is still closed.	
	ELEVATION PROX SWITCH PERMANENTLY OPEN	Reported when the elevation rotary sensor is reporting stowed and the elevation proximity switch is open.	
	FRONT LEFT LEVELING JACK PRESSURE TRANSDUCER FAILURE	Reported when the front left leveling jack pressure reading is well below OPSI.	
	FRONT RIGHT LEVELING JACK PRESSURE TRANSDUCER FAILURE	Reported when the front right leveling jack pressure reading is well below OPSI.	
	REAR LEFT LEVELING JACK PRESSURE TRANSDUCER FAILURE	Reported when the rear left leveling jack pressure reading is well below OPSI.	
	REAR RIGHT LEVELING JACK PRESSURE TRANSDUCER FAILURE	Reported when the rear right leveling jack pressure reading is well below OPSI.	
	PLATFORM OVERLOAD	Reported when the overload is setup and the LSS is reading the platform is overloaded.	
2/5	FRONT LEFT LEVELING JACK STOW SWITCH PERMANENTLY CLOSED	Reported when the FRONT LEFT Leveling Jack Stow Switch is closed and the FRONT LEFT pressure transducer reads "Set" pressure.	5
	FRONT RIGHT LEVELING JACK STOW SWITCH PERMANENTLY CLOSED	Reported when the FRONT RIGHT Leveling Jack Stow Switch is closed and FRONT RIGHT pressure transducer reads "Set" pressure.	
	REAR LEFT LEVELING JACK STOW SWITCH PERMANENTLY CLOSED	Reported when the REAR LEFT Leveling Jack Stow Switch is closed and the REAR LEFT pressure transducer reads "Set" pressure.	
	REAR RIGHT LEVELING JACK STOW SWITCH PERMANENTLY CLOSED	Reported when the REAR RIGHT Leveling Jack Stow Switch is closed and the REAR RIGHT pressure transducer reads "Set" pressure.	
	ELEV ANGLE SENSOR HAS NOT BEEN CALIBRATED	Reported when elevation height calibration has not been performed or is not logical (increasing voltages from stowed). Vehicle assumed to be at full height.	
	ELEV ANGLE SENSOR FAULTY - NOT MOUNTED OR VOLTAGE OUT OF RANGE	Reported when elevation angle sensor is outside the 0.30V to 4.85V range. Vehicle assumed to be at full height.	
	ELEV ANGLE SENSOR NOT DETECTING CHANGE	Reported when elevation angle sensor voltage does not change for 5 sec during lift up > 20%. Vehicle assumed to be at full height. Fault cleared only in valid stowed position.	

Table 5-2. Fault Code Listing - Software P1.X

Fault Flash Code	Communicated (Displayed on Analyzer) Fault	Description	Priority
2/6		Flash code 2/6 indicates leveling jack or power deck issues.	6
	FRONT LEFT LEVELING JACK OPEN CIRCUIT	Reported by the I/O module and during system test when the front left leveling jack is open circuit.	
	FRONT LEFT LEVELING JACK SHORT TO GROUND	Reported by the I/O module and during system test when the front left leveling jack is short to ground.	
	FRONT LEFT LEVELING JACK SHORT TO BATTERY	Reported by the I/O module and during system test when the front left leveling jack is short to battery.	
	FRONT RIGHT LEVELING JACK OPEN CIRCUIT	Reported by the I/O module and during system test when the front right leveling jack is open circuit.	
	FRONT RIGHT LEVELING JACK SHORT TO GROUND	Reported by the I/O module and during system test when the front right leveling jack is short to ground.	
	FRONT RIGHT LEVELING JACK SHORT TO BATTERY	Reported by the I/O module and during system test when the front right leveling jack is short to battery.	
	REAR LEFT LEVELING JACK OPEN CIRCUIT	Reported by the I/O module and during system test when the rear left leveling jack is open circuit.	
	REAR LEFT LEVELING JACK SHORT TO GROUND	Reported by the I/O module and during system test when the rear left leveling jack is short to ground.	
	REAR LEFT LEVELING JACK SHORT TO BATTERY	Reported by the I/O module and during system test when the rear left leveling jack is short to battery.	
	REAR RIGHT LEVELING JACK OPEN CIRCUIT	Reported by the I/O module and during system test when the rear right leveling jack is open circuit.	
	REAR RIGHT LEVELING JACK SHORT TO GROUND	Reported by the I/O module and during system test when the rear right leveling jack is short to ground.	
	REAR RIGHT LEVELING JACK SHORT TO BATTERY	Reported by the I/O module and during system test when the rear right leveling jack is short to battery.	
	LEVELING JACK EXTEND VALVE OPEN CIRCUIT	Reported by the I/O module and during system test when the leveling jack extend valve is open circuit.	
	LEVELING JACK EXTEND VALVE SHORT TO GROUND	Reported by the I/O module and during system test when the leveling jack extend valve is short to ground.	
	LEVELING JACK EXTEND VALVE SHORT TO BATTERY	Reported by the I/O module and during system test when the leveling jack extend valve is short to battery.	
	LEVELING JACK RETRACT VALVE OPEN CIRCUIT	Reported by the I/O module and during system test when the leveling jack retract valve is open circuit.	
	LEVELING JACK RETRACT VALVE SHORT TO GROUND	Reported by the I/O module and during system test when the leveling jack retract valve is short to ground.	
	LEVELING JACK RETRACT VALVE SHORT TO BATTERY	Reported by the I/O module and during system test when the leveling jack retract valve is short to battery.	
	FRONT DECK EXTEND VALVE OPEN CIRCUIT	Reported by the I/O module and during system test when the front deck extend valve is open circuit.	
FRONT DECK EXTEND VALVE SHORT TO GROUND	Reported by the I/O module and during system test when the front deck extend valve is short to ground.		
FRONT DECK EXTEND VALVE SHORT TO BATTERY	Reported by the I/O module and during system test when the front deck extend valve is short to battery.		
FRONT DECK RETRACT VALVE OPEN CIRCUIT	Reported by the I/O module and during system test when the front deck retract valve is open circuit.		

SECTION 5 - JLG CONTROL SYSTEM

Table 5-2. Fault Code Listing - Software P1.X

Fault Flash Code	Communicated (Displayed on Analyzer) Fault	Description	Priority
2/6	FRONT DECK RETRACT VALVE SHORT TO GROUND	Reported by the I/O module and during system test when the front deck retract valve is short to ground.	6
	FRONT DECK RETRACT VALVE SHORT TO BATTERY	Reported by the I/O module and during system test when the front deck retract valve is short to battery.	
	REAR DECK EXTEND VALVE OPEN CIRCUIT	Reported by the I/O module and during system test when the rear deck extend valve is open circuit.	
	REAR DECK EXTEND VALVE SHORT TO GROUND	Reported by the I/O module and during system test when the rear deck extend valve is short to ground.	
	REAR DECK EXTEND VALVE SHORT TO BATTERY	Reported by the I/O module and during system test when the rear deck extend valve is short to battery.	
	REAR DECK RETRACT VALVE OPEN CIRCUIT	Reported by the I/O module and during system test when the rear deck retract valve is open circuit.	
	REAR DECK RETRACT VALVE SHORT TO GROUND	Reported by the I/O module and during system test when the rear deck retract valve is short to ground.	
	REAR DECK RETRACT VALVE SHORT TO BATTERY	Reported by the I/O module and during system test when the rear deck retract valve is short to battery.	
4/3		Flash code 4/3 indicates engine issues.	7
	FUEL SENSOR SHORT TO BATTERY	Reported when the fuel sensor is reading a value that is much too high.	
	FUEL SENSOR SHORT TO GROUND	Reported when the fuel sensor is reading ground.	
	FUEL SENSOR DISCONNECTED	Reported when the fuel sensor is reading a value that is too high.	
	OIL PRESSURE SHORT TO BATTERY	Reported when the oil pressure sensor is reading a value that is too high.	
	OIL PRESSURE SHORT TO GROUND	Reported when the oil pressure sensor is reading a value that is too low.	
	COOLANT TEMPERATURE SHORT TO GROUND	Reported when the coolant temperature sensor is reading a value that is too low.	
	ENGINE TEMPERATURE HIGH	This fault is not reported at this time.	
	AIR FILTER BYPASSED	This fault is not reported at this time.	
	NO ALTERNATOR OUTPUT	Reported when the engine is running for at least a few seconds and the alternator input is on the ground board is high.	
	OIL PRESSURE LOW	Reported when the oil pressure is below eight PSI and the engine is running for at least a few seconds.	
	ENGINE SHUTDOWN COMMANDED – CHECK ENGINE SENSORS	Reported when the engine is commanded to shutdown by the control system.	
	WRONG ENGINE SELECTED	Reported when CAN ECM is detected and not configured.	
DEUTZ ECM FAULT CODE	Reported when the Deutz Engine Controller is giving a fault. See engine manual for more information.		
4/4		Flash code 4/4 indicates a battery supply issue.	8
	BATTERY LOW	Reported when the voltage on the system is below 11 volts.	
	BATTERY TOO HIGH – SYSTEM SHUTDOWN	Reported when the voltage on the system is above 16 volts.	
	BATTERY TOO LOW – SYSTEM SHUTDOWN	Reported when the voltage on the system is below 9 volts.	
	LSS BATTERY VOLTAGE HIGH	Reported when the voltage on the LSS is above 34 volts.	
	LSS BATTERY VOLTAGE LOW	Reported when the voltage on the LSS is below 9 volts.	

Table 5-2. Fault Code Listing - Software P1.X

Fault Flash Code	Communicated (Displayed on Analyzer) Fault	Description	Priority
5/5		Flash code 5/5 indicates a speed sensor issue.	9
	SPEED SENSOR READING INVALID SPEED	Reported when the speed sensor is reading a value over 4000 RPM.	
	SPEED INPUT LOST	Reported when the speed sensor is reading zero RPM and the oil pressure is over eight PSI.	
6/6		Flash code 6/6 indicates CANbus issues.	10
	CAN BUS FAILURE	Reported when there is a problem with the CANbus.	
	LSS NOT SENDING CAN MESSAGES	Reported when the LSS is configured and not seen on the CANbus.	
	ENGINE CONTROLLER CAN COMMUNICATION LOST	Reported when the engine is configured to be CAN controlled and the system is not communicating with it.	
	TWO PLATFORM MODULES DETECTED	Reported when there are two platform modules connected to the control system.	
8/*		Flash codes 8/* indicate load cells issues.	11
8/1	LSS CELL #1 ERROR	Reported when there is a problem with cell #1 on the LSS.	
8/2	LSS CELL #2 ERROR	Reported when there is a problem with cell #2 on the LSS.	
8/3	LSS CELL #3 ERROR	Reported when there is a problem with cell #3 on the LSS.	
8/4	LSS CELL #4 ERROR	Reported when there is a problem with cell #4 on the LSS.	
9/*		Flash codes 9/* indicate LSS or memory issues.	12
9/1	LSS WATCHDOG RESET	Reported when the LSS's microprocessor watchdog has been triggered.	
9/2	LSS EEPROM ERROR	Reported when there is a problem with the stored memory in the LSS.	
9/3	LSS HAS NOT BEEN CALIBRATED	Reported when the LSS is configured but not calibrated.	
9/9	LSS NEEDS TO BE RE-CALIBRATED	Reported when the LSS is configured and reporting a value that is less than half of the offset value; this will be reported as a negative value.	
	LSS INTERNAL ERROR – PIN EXCITATION	Reported when a pin in the LSS is reporting a voltage below 4.25 volts.	
	LSS INTERNAL ERROR – DRIVER FAULT	Reported when the LSS detects this internal error.	
	LSS INTERNAL ERROR – DRDY MISSING FROM A/D	Reported when the LSS detects this internal error.	
	EEPROM FAILURE – CHECK ALL SETTINGS	Reported when the memory in the ground or platform module has become corrupt.	

4150588 D

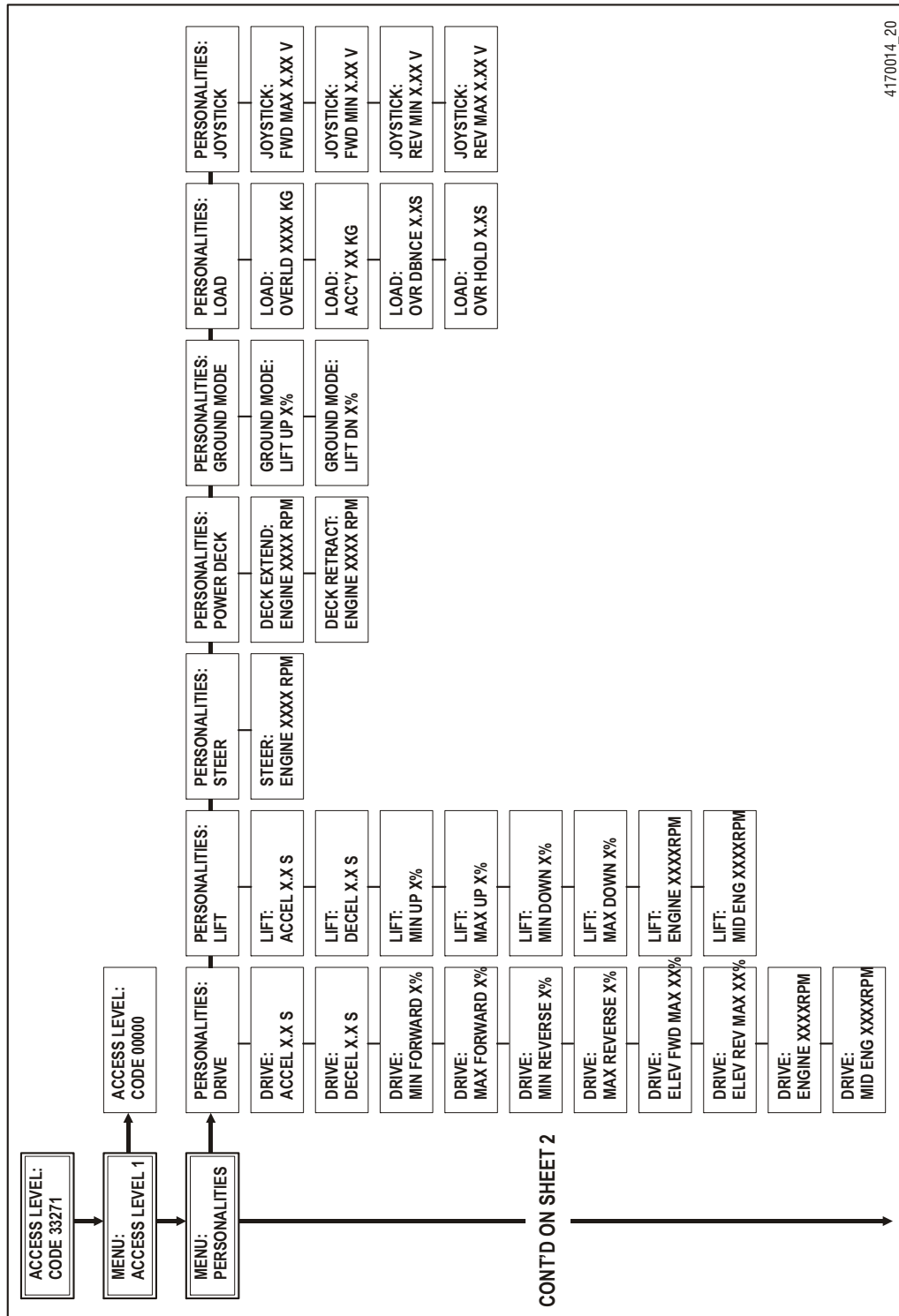

4170014_20

Figure 5-6. Analyzer Flow Chart - SW P1.X - Sheet 1 of 3

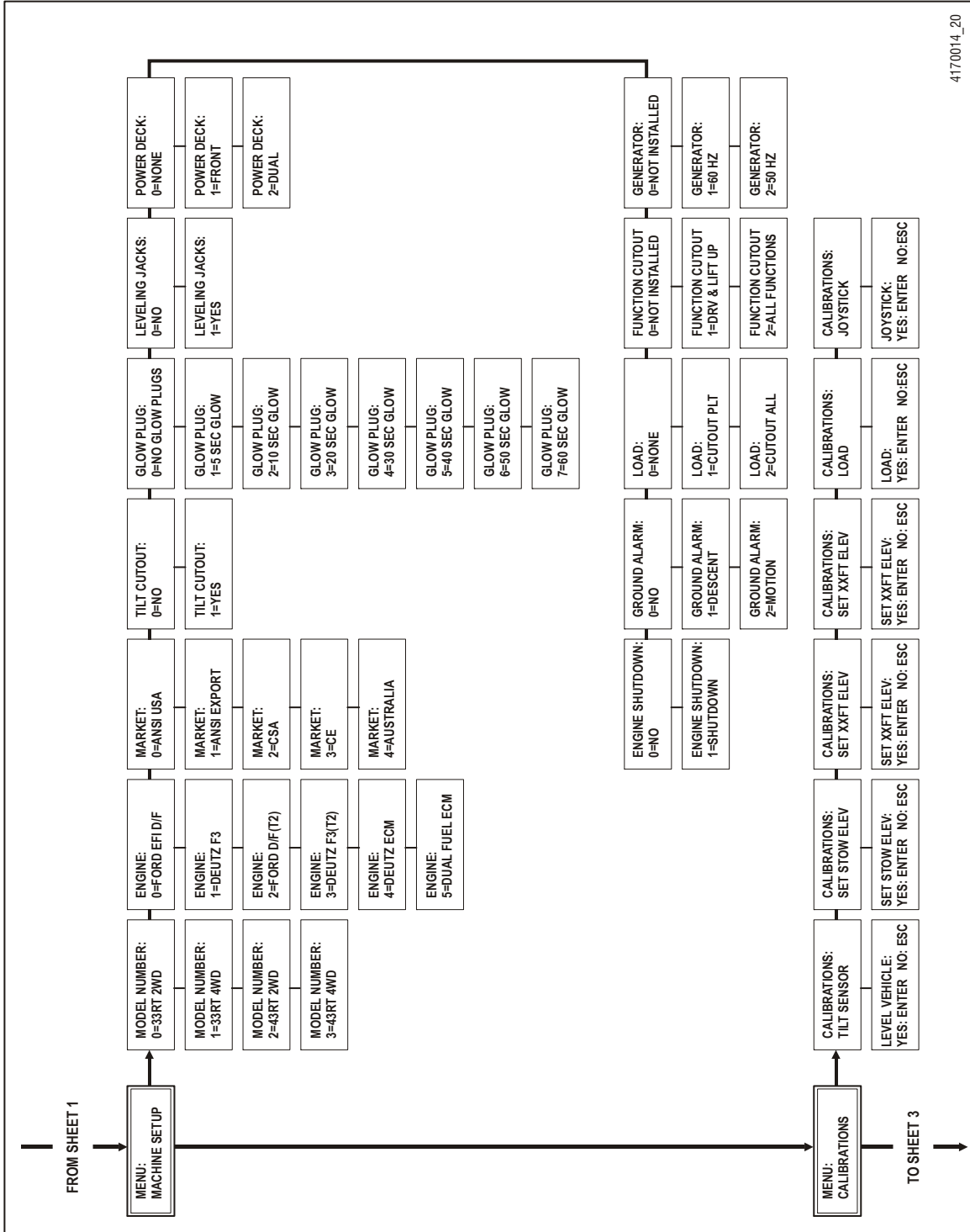

4170014_20

Figure 5-7. Analyzer Flow Chart - SW P1.X - Sheet 2 of 3

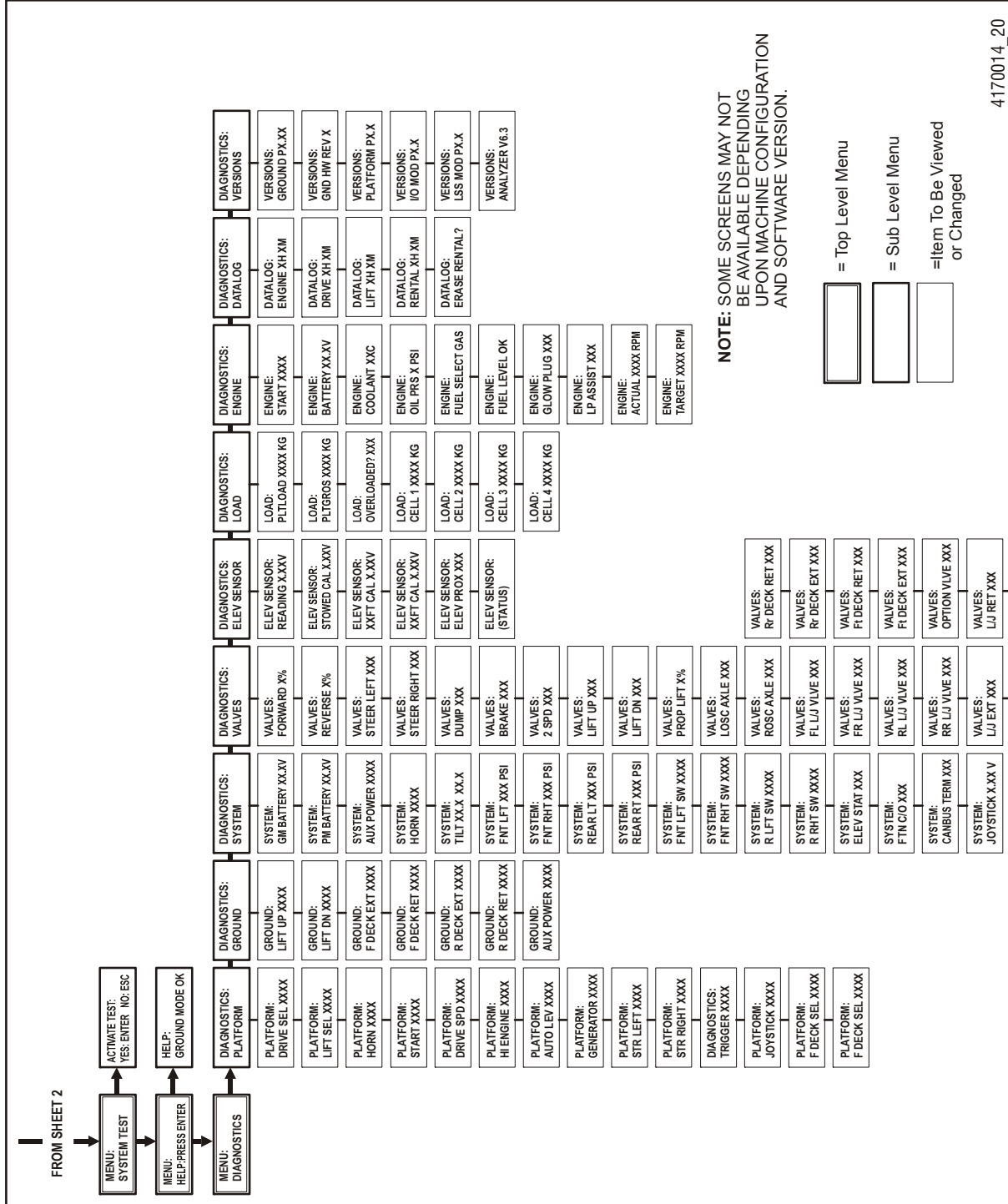

Figure 5-8. Analyzer Flow Chart - SW P1.X - Sheet 3 of 3

NOTE: When configuring an RT, the Machine Configuration must be completed before any Personality settings can be changed. Changing the Personality settings first and then changing the Model of the Machine Configuration will cause the Personality settings to return to default values.

Table 5-3. Machine Configuration Programming Information

Configuration Digit	Setting	Description	Default Number
1 (MODEL)	0	33RT 2WD	1
	1	33RT 4WD	
	2	43RT 2WD	
	3	43RT 4WD	
2 (ENGINE)	0	FORD EF1 D/F	4
	1	DEUTZ F3	
	2	FORD D/F (T2)	
	3	DEUTZ F3 (T2)	
	4	DEUTZ ECM	
3 (MARKET)	0	ANSI USA	0
	1	ANSI EXPORT	
	2	CSA	
	3	CE	
	4	AUSTRALIA	
4 (TILT CUTOUT)	0	NO - Tilt Cutout is not active	1
	1	Yes - Tilt Cutout is active (Screen only visible to CE Market)	
5 (GLOW PLUGS)	0	NO GLOW PLUGS	5
	1	5 SEC GLOW	
	2	10 SEC GLOW	
	3	20 SEC GLOW	
	4	30 SEC GLOW	
	5	40 SEC GLOW	
	6	50 SEC GLOW	
7	60 SEC GLOW		
6 (LEVELING JACKS)	0	No - Leveling Jacks not installed on vehicle.	0
	1	YES - Leveling Jacks are installed on vehicle.	
7 (POWER DECK)	0	NONE - Power Deck Extensions not installed on vehicle.	0
	1	FRONT - Power Deck Extension is installed on the Front of the vehicle.	
	2	DUAL - Power Deck Extensions are installed on the Front and Rear of the vehicle.	
8 (GENERATOR)	0	NOT INSTALLED - Generator is not installed on the vehicle.	0
	1	60HZ - Generator is installed and engine speed set for 2000RPM when enabled.	
	2	50HZ - Generator is installed and engine speed set for 1700RPM when enabled.	
9 (FUNCTION CUTOUT)	0	NOT INSTALLED - Vehicle is not equipped with a Function Cutout device.	0
	1	DRV & LIFT UP - Vehicle is equipped with a Function Cutout device. Drive and Lift Up will be prevented when active.	
	2	ALL FUNCTIONS - Vehicle is equipped with a Function Cutout device. All Functions will be prevented when active.	

SECTION 5 - JLG CONTROL SYSTEM

Table 5-3. Machine Configuration Programming Information

Configuration Digit	Setting	Description	Default Number
10 (LOAD)	0	NOT INSTALLED – Load Sensing System (LSS) is not fitted to the vehicle.	0
	1	CUTOFF PLT – Load Sensing System (LSS) is fitted, and Platform Controls are prevented in the event of an Overload. Ground Controls remain functional. This is the default setting for CE machines.	
	2	CUTOFF ALL – Load Sensing System (LSS) is fitted. Platform and Ground Controls are prevented in the event of an Overload. NOTE: <i>Certain market selections will alter default setting.</i>	
11 (GROUND ALARM)	0	NOT INSTALLED – Vehicle alarm will function for Overload (if LOAD enabled).	2
	1	DESCENT – Vehicle alarm will function for Overload (if LOAD enabled) and during Lift Down motion.	
	2	MOTION – Vehicle alarm will function for Overload (if LOAD enabled), during Drive motion, and during Lift motion. NOTE: <i>Certain market selections will alter default setting.</i>	
12 (ENGINE SHUTDOWN)	0	NO - The engine will not be automatically shutdown.	1
	1	SHUTDOWN - The engine will automatically shutdown in the event of high engine coolant temperature, low oil pressure, or a temperature sensor or oil pressure sensor fault.	

4150390 J

Table 5-4. Machine Tilt Configuration

Model	Market	Limits
33RT 2WD, 33RT 4WD	ANSI USA	Lift Up and Drive prevented when Elevated and Tilted beyond the following limits: Front to Back: $\pm 5^\circ$ to Full Height Side to Side: $\pm 5^\circ$ to 26 Feet; $\pm 4^\circ$ to 30 Feet; $\pm 3^\circ$ to Full Height
	ANSI EXPORT	Same as ANSI USA
	CSA	Lift Up and Drive prevented when Elevated and Tilted beyond the following limits: Front to Back: $\pm 3^\circ$ to Full Height Side to Side: $\pm 3^\circ$ to Full Height
	CE	Tilt Lamp energized when Tilted beyond the following limits: Front to Back: $\pm 5^\circ$ to Full Height Side to Side: $\pm 3^\circ$ to Full Height
	AUSTRALIA	Same as ANSI USA
43RT 2WD 43RT 4WD	ANSI USA	Lift Up and Drive prevented when Elevated and Tilted beyond the following limits: Front to Back: $\pm 5^\circ$ to Full Height Side to Side: $\pm 5^\circ$ to 30 Feet; $\pm 4^\circ$ to 36 Feet; $\pm 3^\circ$ to Full Height
	ANSI EXPORT	Same as ANSI USA
	CSA	Lift Up and Drive prevented when Elevated and Tilted beyond the following limits: Front to Back: $\pm 3^\circ$ to Full Height Side to Side: $\pm 3^\circ$ to Full Height
	CE	Tilt Lamp energized when Tilted beyond the following limits: Front to Back: $\pm 5^\circ$ to Full Height Side to Side: $\pm 3^\circ$ to Full Height
	AUSTRALIA	Same as ANSI USA

4150390 J

NOTE: *Vehicle Tilt Configuration based on Model and Market Settings*

SECTION 5 - JLG CONTROL SYSTEM

NOTE: *Bold Italic Numbers indicate the default setting. Plain text indicates another available selection. Bold, Italic underlined numbers indicate the default when the option is factory installed.*

3394RT 2WD																		
	MODEL NUMBER	ENGINE	MARKET	TILT CUTOUT		GLOW PLUG							LEVELING JACKS		POWER DECK			
ANSI USA	0	4	0	X	1	0	1	2	3	4	5	6	7	0	1	0	1	2
ANSI EXPORT	0	4	1	X	1	0	1	2	3	4	5	6	7	0	1	0	1	2
CSA	0	4	2	X	1	0	1	2	3	4	5	6	7	0	1	0	1	2
CE	0	4	3	0	1	0	1	2	3	4	5	6	7	0	1	0	1	2
AUSTRALIA	0	4	4	X	1	0	1	2	3	4	5	6	7	0	1	0	1	2

3394RT 2WD														
	GENERATOR			FUNCTION CUTOUT			LOAD			GROUND ALARM			ENGINE SHUTDOWN	
ANSI USA	0	1	2	0	1	2	0	X	X	0	1	2	0	1
ANSI EXPORT	0	1	2	0	1	2	0	1	2	0	1	2	0	1
CSA	0	1	2	0	1	2	0	X	X	0	1	2	0	1
CE	0	1	2	0	1	2	0	1	2	0	1	2	0	1
AUSTRALIA	0	1	2	0	1	2	0	1	X	X	X	2	0	1

4150390 K

SECTION 5 - JLG CONTROL SYSTEM

NOTE: .Bold Italic Numbers indicate the default setting. Plain text indicates another available selection. Bold, Italic underlined numbers indicate the default when the option is factory installed.

3394RT 4WD																		
	MODEL NUMBER	ENGINE	MARKET	TILT CUTOUT		GLOW PLUG							LEVELING JACKS		POWER DECK			
ANSI USA	1	4	0	X	1	0	1	2	3	4	5	6	7	0	1	0	1	2
ANSI EXPORT	1	4	1	X	1	0	1	2	3	4	5	6	7	0	1	0	1	2
CSA	1	4	2	X	1	0	1	2	3	4	5	6	7	0	1	0	1	2
CE	1	4	3	0	1	0	1	2	3	4	5	6	7	0	1	0	1	2
AUSTRALIA	1	4	4	X	1	0	1	2	3	4	5	6	7	0	1	0	1	2

3394RT 4WD														
	GENERATOR			FUNCTION CUTOUT			LOAD			GROUND ALARM			ENGINE SHUTDOWN	
ANSI USA	0	1	2	0	1	2	0	X	X	0	1	2	0	1
ANSI EXPORT	0	1	2	0	1	2	0	1	2	0	1	2	0	1
CSA	0	1	2	0	1	2	0	X	X	0	1	2	0	1
CE	0	1	2	0	1	2	0	1	2	0	1	2	0	1
AUSTRALIA	0	1	2	0	1	2	0	1	X	X	X	2	0	1

4150390 K

SECTION 5 - JLG CONTROL SYSTEM

NOTE: *Bold Italic Numbers indicate the default setting. Plain text indicates another available selection. Bold, Italic underlined numbers indicate the default when the option is factory installed.*

4394RT 2WD																		
	MODEL NUMBER	ENGINE	MARKET	TILT CUTOUT		GLOW PLUG							LEVELING JACKS		POWER DECK			
ANSI USA	2	4	0	X	1	0	1	2	3	4	5	6	7	0	1	0	1	2
ANSI EXPORT	2	4	1	X	1	0	1	2	3	4	5	6	7	0	1	0	1	2
CSA	2	4	2	X	1	0	1	2	3	4	5	6	7	0	1	0	1	2
CE	2	4	3	0	1	0	1	2	3	4	5	6	7	0	1	0	1	2
AUSTRALIA	2	4	4	X	1	0	1	2	3	4	5	6	7	0	1	0	1	2

4394RT 2WD														
	GENERATOR			FUNCTION CUTOUT			LOAD			GROUND ALARM			ENGINE SHUTDOWN	
ANSI USA	0	1	2	0	1	2	0	X	X	0	1	2	0	1
ANSI EXPORT	0	1	2	0	1	2	0	1	2	0	1	2	0	1
CSA	0	1	2	0	1	2	0	X	X	0	1	2	0	1
CE	0	1	2	0	1	2	0	1	2	0	1	2	0	1
AUSTRALIA	0	1	2	0	1	2	0	1	X	X	X	2	0	1

4150390 K

SECTION 5 - JLG CONTROL SYSTEM

NOTE: *Bold Italic Numbers indicate the default setting. Plain text indicates another available selection. Bold, Italic underlined numbers indicate the default when the option is factory installed.*

4394RT 4WD																		
	MODEL NUMBER	ENGINE	MARKET	TILT CUTOUT		GLOW PLUG							LEVELING JACKS		POWER DECK			
ANSI USA	3	4	0	X	1	0	1	2	3	4	5	6	7	0	1	0	1	2
ANSI EXPORT	3	4	1	X	1	0	1	2	3	4	5	6	7	0	1	0	1	2
CSA	3	4	2	X	1	0	1	2	3	4	5	6	7	0	1	0	1	2
CE	3	4	3	0	1	0	1	2	3	4	5	6	7	0	1	0	1	2
AUSTRALIA	3	4	4	X	1	0	1	2	3	4	5	6	7	0	1	0	1	2

4394RT 4WD														
	GENERATOR			FUNCTION CUTOUT			LOAD			GROUND ALARM			ENGINE SHUTDOWN	
ANSI USA	0	1	2	0	1	2	0	X	X	0	1	2	0	1
ANSI EXPORT	0	1	2	0	1	2	0	1	2	0	1	2	0	1
CSA	0	1	2	0	1	2	0	X	X	0	1	2	0	1
CE	0	1	2	0	1	2	0	1	2	0	1	2	0	1
AUSTRALIA	0	1	2	0	1	2	0	1	X	X	X	2	0	1

4150390 K

Table 5-5. Machine Model Adjustment

Adjustment	Adjustment Range	Model Default Values			
		3394RT 2WD	3394RT 4WD	4394RT 2WD	4394RT 4WD
DRIVE					
Accel	0.1 - 5.0 (sec)	3	3	3	3
Decel	0.1 - 3.0 (sec)	1.2	1.2	1.2	1.2
Min Forward	0 - 35%	24	24	24	24
Max Forward	0 - 100%	56	56	56	56
Min Reverse	0 - 35%	24	24	24	24
Max Reverse	0 - 100%	55	55	55	55
Elev Fwd Max	20 - 50%	41	41	41	41
Elev Rev Max	21 - 50%	41	41	41	41
Engine	800 - 2900RPM	2800	2800	2800	2800
Mid Engine	800 - 2700RPM	2000	2000	2000	2000
LIFT					
Accel	0.1 - 5.0 (sec)	2	2	2	2
Decel	0.8 - 1.5 (sec)	1	1	1	1
Min Up	0 - 35%	12	12	12	12
Max Up	0 - 65%	55	55	45	45
Min Down	0 - 35%	12	12	12	12
Max Down	0 - 65%	55	55	40	40
Engine	800 - 2900RPM	2800	2800	2800	2800
Mid Engine	800 - 2700RPM	2000	2000	2000	2000
STEER					
Engine	800 - 2900RPM	2800	2800	2800	2800
POWER DECK					
Deck Extend	800 - 2900RPM	1200	1200	1200	1200
Deck Retract	800 - 2900RPM	1200	1200	1200	1200
GROUND					
Lift Up	0 - 65%	55	55	45	45
Lift Down	0 - 65%	55	55	40	40
LOAD					
Overload	1000 - 2700 lbs (454 - 1225 kg)	2475 (1123 kg)	2475 (1123 kg)	1650 (748 kg)	1650 (748 kg)
Acc'y	0 - 500 lbs (0 - 227 kg)	0	0	0	0
Overload Dbnce	0 - 10 (sec)	3	3	3	3
Overload Hold	1 - 10 (sec)	5	5	5	5
JOYSTICK					
Forward Max	0.00 - 5.00V	0.75	0.75	0.75	0.75
Forward Min	0.00 - 5.00V	2.24	2.24	2.24	2.24
Reverse Min	0.00 - 5.00V	2.82	2.82	2.82	2.82
Reverse Max	0.00 - 5.00V	4.32	4.32	4.32	4.32

4150389 D

NOTE: These settings may be changed in order to achieve optimal performance.

SECTION 6. GENERAL ELECTRICAL INFORMATION & SCHEMATICS

6.1 GENERAL

This section contains schematics to be used for locating and correcting most of the operating problems which may develop. If a problem should develop which is not presented in this section or which is not corrected by listed corrective actions, technically qualified guidance should be obtained before proceeding with any maintenance.

NOTICE

IT IS A GOOD PRACTICE TO AVOID PRESSURE-WASHING ELECTRICAL/ELECTRONIC COMPONENTS. SHOULD PRESSURE-WASHING BE UTILIZED TO WASH AREAS CONTAINING ELECTRICAL/ELECTRONIC COMPONENTS, JLG INDUSTRIES, INC. RECOMMENDS A MAXIMUM PRESSURE OF 750 PSI (52 BAR) AT A MINIMUM DISTANCE OF 12 INCHES (30.5 CM) AWAY FROM THESE COMPONENTS. IF ELECTRICAL/ELECTRONIC COMPONENTS ARE SPRAYED, SPRAYING MUST NOT BE DIRECT AND BE FOR BRIEF TIME PERIODS TO AVOID HEAVY SATURATION.

6.2 MULTIMETER BASICS

A wide variety of multimeters or Volt Ohm Meters (VOM) can be used for troubleshooting your equipment. A digital meter with reasonable accuracy (within 7%) is recommended for the measurements in these procedures. This section shows diagrams of a common, digital VOM configured for several different circuit measurements. Instructions for your VOM may vary. Please consult the meter operator's manual for more information.

Grounding

"Grounding the meter" means to take the black lead (which is connected to the COM (common) or negative port) and touch it to a good path to the negative side of the voltage source.

Backprobing

To "backprobe" means to take the measurement by accessing a connector's contact on the same side as the wires, the back of the connector. Readings can be done while maintaining circuit continuity this way. If the connector is the sealed type, great care must be taken to avoid damaging the seal around the wire. It is best to use probes or probe tips specifically designed for this technique, especially on sealed connectors. Whenever possible insert probes into the side of the connector such that the test also checks both terminals of the connection. It is possible to inspect a connection within a closed connector by backprobing both sides of a connector terminal and measuring resistance. Do this after giving each wire a gentle pull to ensure the wires are still attached to the contact and contacts are seated in the connector.

Min/Max

Use of the "Min/Max" recording feature of some meters can help when taking measurements of intermittent conditions while alone. For example, you can read the voltage applied to a solenoid when it is only operational while a switch, far from the solenoid and meter, is held down.

Polarity

Finding a negative voltage or current reading when expecting a positive reading frequently means the leads are reversed. Check what reading is expected, the location of the signal and that the leads are connected to the device under test correctly. Also check that the lead on the "COM" port goes to the ground or negative side of the signal and the lead on the other port goes to the positive side of the signal.

Scale

M = Mega = 1,000,000 * (Displayed Number)

k = kilo = 1,000 * (Displayed Number)

m = milli = (Displayed Number) / 1,000

μ = micro = (Displayed Number) / 1,000,000

Example: 1.2 k Ω = 1200 Ω

Example: 50 mA = 0.05 A

Voltage Measurement

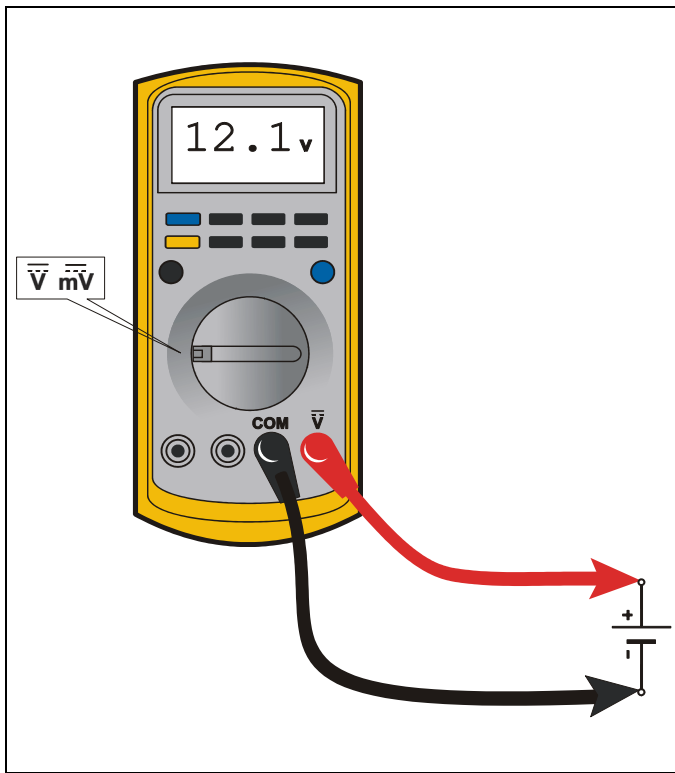

Figure 6-1. Voltage Measurement (DC)

- If meter is not auto ranging, set it to the correct range (See multimeter's operation manual)
- Use firm contact with meter leads

Resistance Measurement

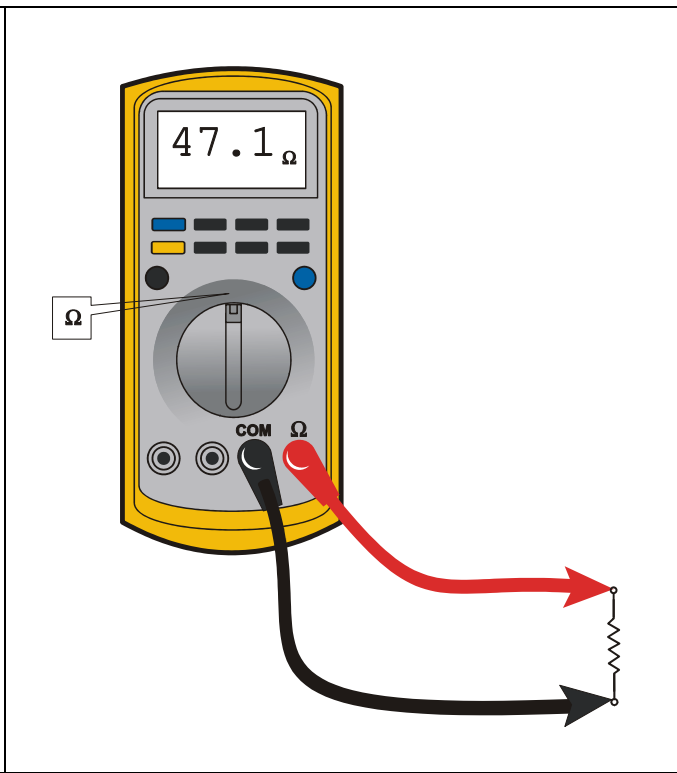

Figure 6-2. Resistance Measurement

- First test meter and leads by touching leads together. Resistance should read a short circuit (very low resistance)
- Circuit power must be turned OFF before testing resistance
- Disconnect component from circuit before testing
- If meter is not auto ranging, set it to the correct range (See multimeter's operation manual)
- Use firm contact with meter leads

Continuity Measurement

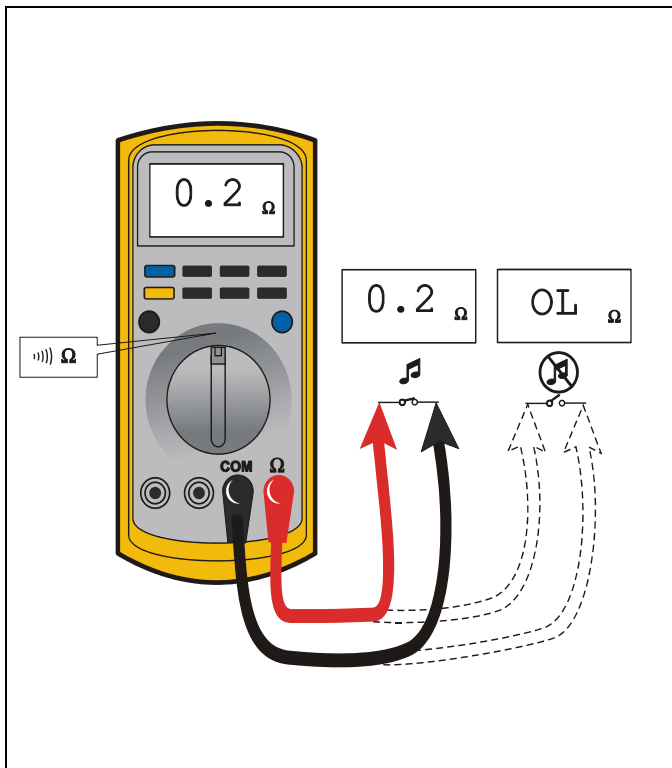

Figure 6-3. Continuity Measurement

- Some meters require a separate button press to enable audible continuity testing
- Circuit power must be turned OFF before testing continuity
- Disconnect component from circuit before testing
- Use firm contact with meter leads
- First test meter and leads by touching leads together. Meter should produce an audible alarm, indicating continuity

Current Measurement

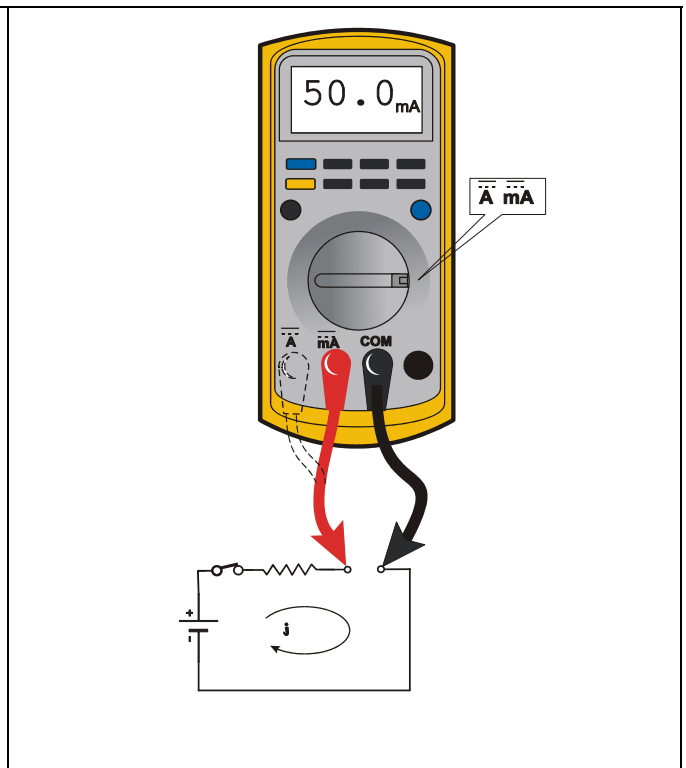

Figure 6-4. Current Measurement (DC)

- Set up the meter for the expected current range
- Be sure to connect the meter leads to the correct jacks for the current range you have selected
- If meter is not auto ranging, set it to the correct range (See multi meter's operation manual)
- Use firm contact with meter leads

Continuity Measurement Over Long Distances

When trying to determine continuity of a harness or wire, longer than the reach of standard instrument leads, is possible to perform the check without excessively long leads. Using the other wires in the harness one can determine the condition of a particular wire in the harness.

Requirements:

- Harness with at least three separate wires including the wire under test.
- These wires must be able to be isolated from other wires, etc.
- Jumper or method to connect contacts on one side of harness.
- Meter that can measure resistance or continuity.

Procedure

Test multimeter leads resistance. Subtract this value from the measured resistance of the wires to get a more accurate measurement.

Consult the circuit schematic to determine which wires to use in addition to wire under test, here called wire #1 and wire #2, and how to isolate these wires. These wires should appear in the same connectors as the wire under test or are within reach of the jumper.

1. Disconnect all connections associated with the wire under test and the two additional wires. If harness is not completely isolated disconnect battery terminals also, as a precaution.
2. Measure continuity between all three wires, the wire under test, wire #1 and wire #2. These should be open. If not, repair the shorted wires or replace the harness.
3. On one side, jumper from contact of wire #1 and wire #2.
4. Measure continuity between wire #1 and wire #2. If there is continuity, both wires are good and can be used for this test. If there is not continuity, either wire could be bad. Check connections and measurement setup. Redo measurement. If still no continuity, repair wires or consult schematic for other wires to use for test.
5. Jumper from wire under test to wire #1.
6. Measure continuity. If there is continuity, the wire under test is good. Resistance of a wire increases as the length increases and as the diameter decreases.

One can find the continuity of two wires, here #1 and #2, at once by following steps 1 through 4. If there is a problem the third wire is used to troubleshoot the other wires. To find the problem, start at step 1 and use the entire procedure.

6.3 APPLYING SILICONE DIELECTRIC COMPOUND TO AMP CONNECTORS

Silicone Dielectric Compound must be used on the AMP connections for the following reasons:

- To prevent oxidation at the mechanical joint between male and female pins.
- To prevent electrical malfunction caused by low level conductivity between pins when wet.

Use the following procedure to apply Silicone Dielectric Compound to the electrical connectors.

1. To prevent oxidation and low level conductivity, silicone dielectric grease must be packed completely around male and female pins on the inside of the connector after the mating of the housing to the header. This is easily achieved by using a syringe to fill the header with silicone dielectric compound, to a point just above the top of the male pins inside the header. When assembling the housing to the header, it is possible that the housing will become air locked, thus preventing the housing latch from engaging.
2. Pierce one of the unused wire seals to allow the trapped air inside the housing to escape.
3. Install a hole plug into this and/or any unused wire seal that has silicone dielectric compound escaping from it.

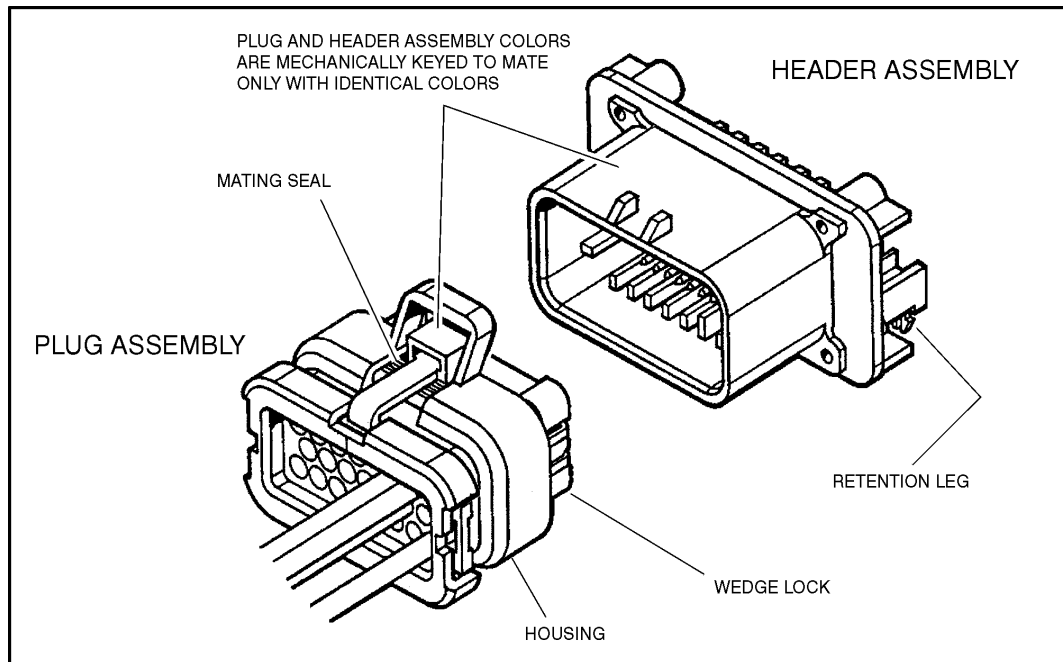

Figure 6-5. AMP Connector

Assembly

Check to be sure the wedge lock is in the open, or as-shipped, position (See Figure 6-6. Connector Assembly (1 of 4)). Proceed as follows:

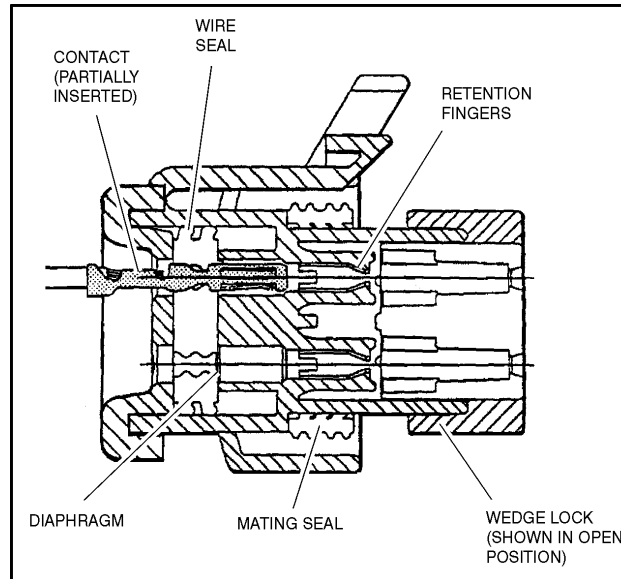

Figure 6-6. Connector Assembly (1 of 4)

1. To insert a contact, push it straight into the appropriate circuit cavity as far as it will go (See Figure 6-7. Connector Assembly (2 of 4)).
2. Pull back on the contact wire with a force of 1 or 2 lbs. to be sure the retention fingers are holding the contact (See Figure 6-7. Connector Assembly (2 of 4)).
3. After all required contacts have been inserted, the wedge lock must be closed to its locked position. Release the locking latches by squeezing them inward (See Figure 6-8. Connector Assembly (3 of 4)).
4. Slide the wedge lock into the housing until it is flush with the housing (See Figure 6-9. Connector Assembly (4 of 4)).

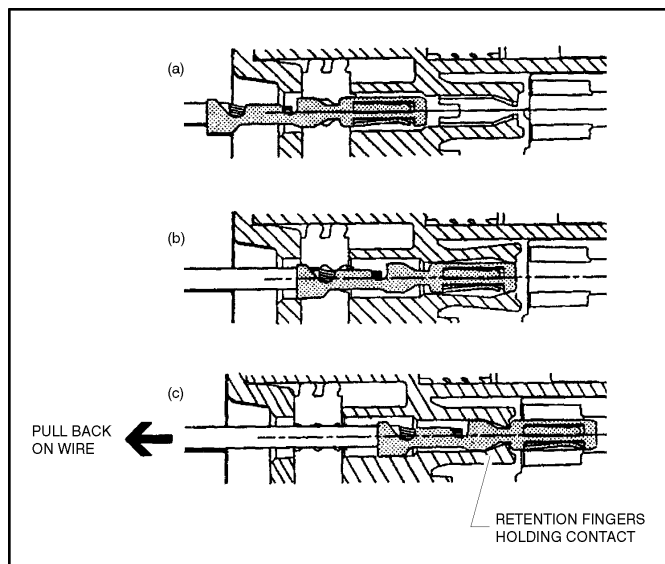

Figure 6-7. Connector Assembly (2 of 4)

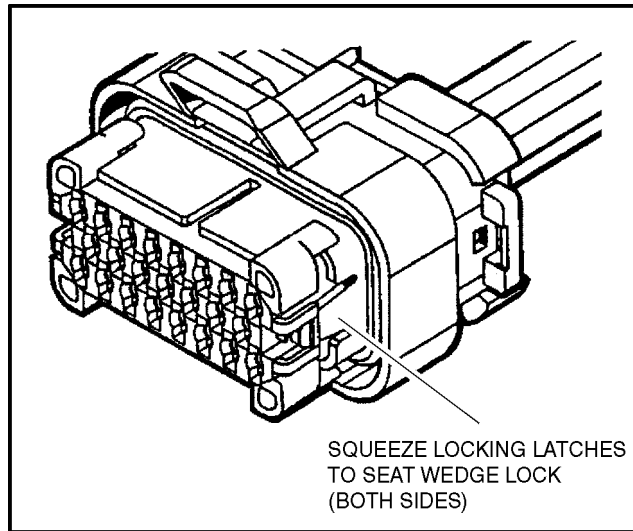

Figure 6-8. Connector Assembly (3 of 4)

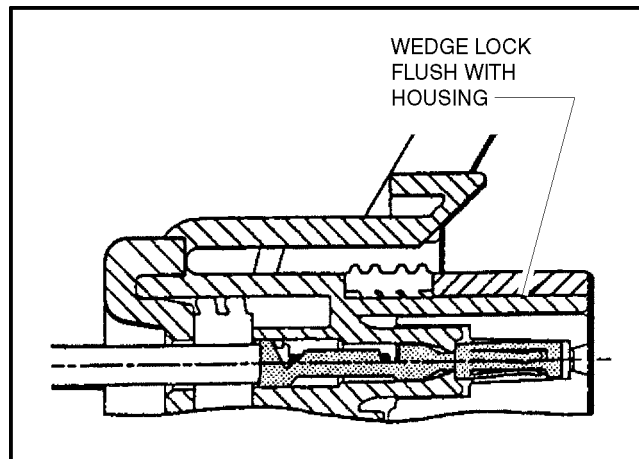

Figure 6-9. Connector Assembly (4 of 4)

Disassembly

5. Insert a 4.8 mm (3/16") wide screwdriver blade between the mating seal and one of the red wedge lock tabs.
6. Pry open the wedge lock to the open position.
7. While rotating the wire back and forth over a half turn (1/4 turn in each direction), gently pull the wire until the contact is removed.

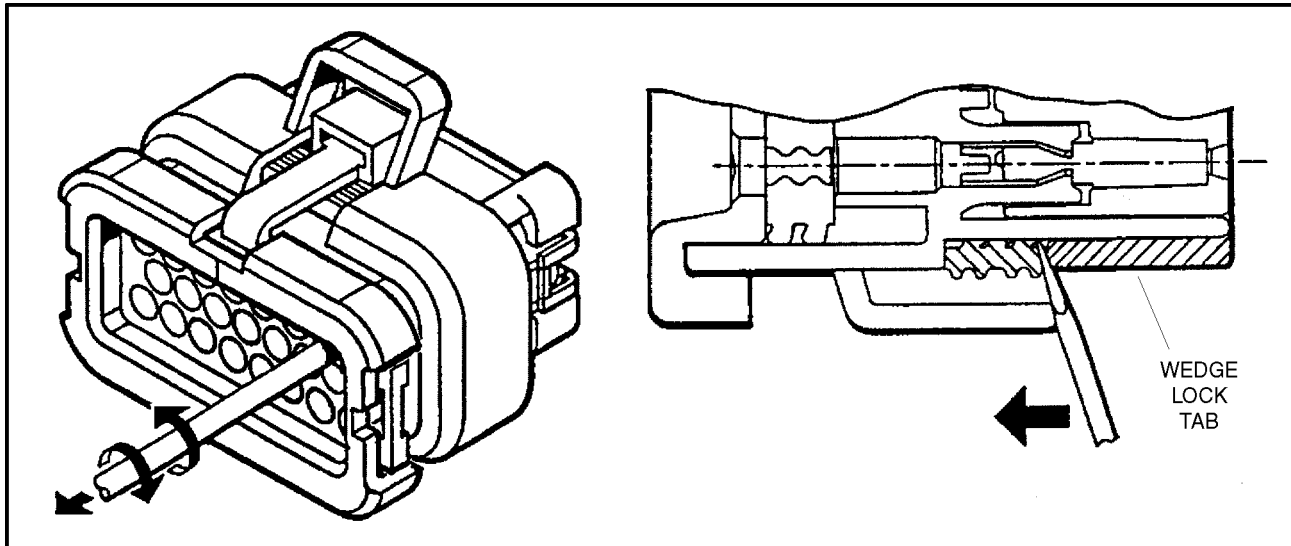

Figure 6-10. Connector Disassembly

NOTE: The wedge lock should never be removed from the housing for insertion or removal of the contacts.

Wedge Lock

The wedge lock has slotted openings in the forward, or mating end. These slots accommodate circuit testing in the field, by using a flat probe such as a pocket knife. DO NOT use a sharp point such as an ice pick.

Service - Voltage Reading

⚠ CAUTION

DO NOT PIERCE WIRE INSULATION TO TAKE VOLTAGE READINGS.

It has been common practice in electrical troubleshooting to probe wires by piercing the insulation with a sharp point. This practice should be discouraged when dealing with the AMPSEAL plug assembly, or any other sealed connector system. The resulting pinholes in the insulation will allow moisture to invade the system by traveling along the wire strands. This nullifies the effectiveness of the connector seals and could result in system failure.

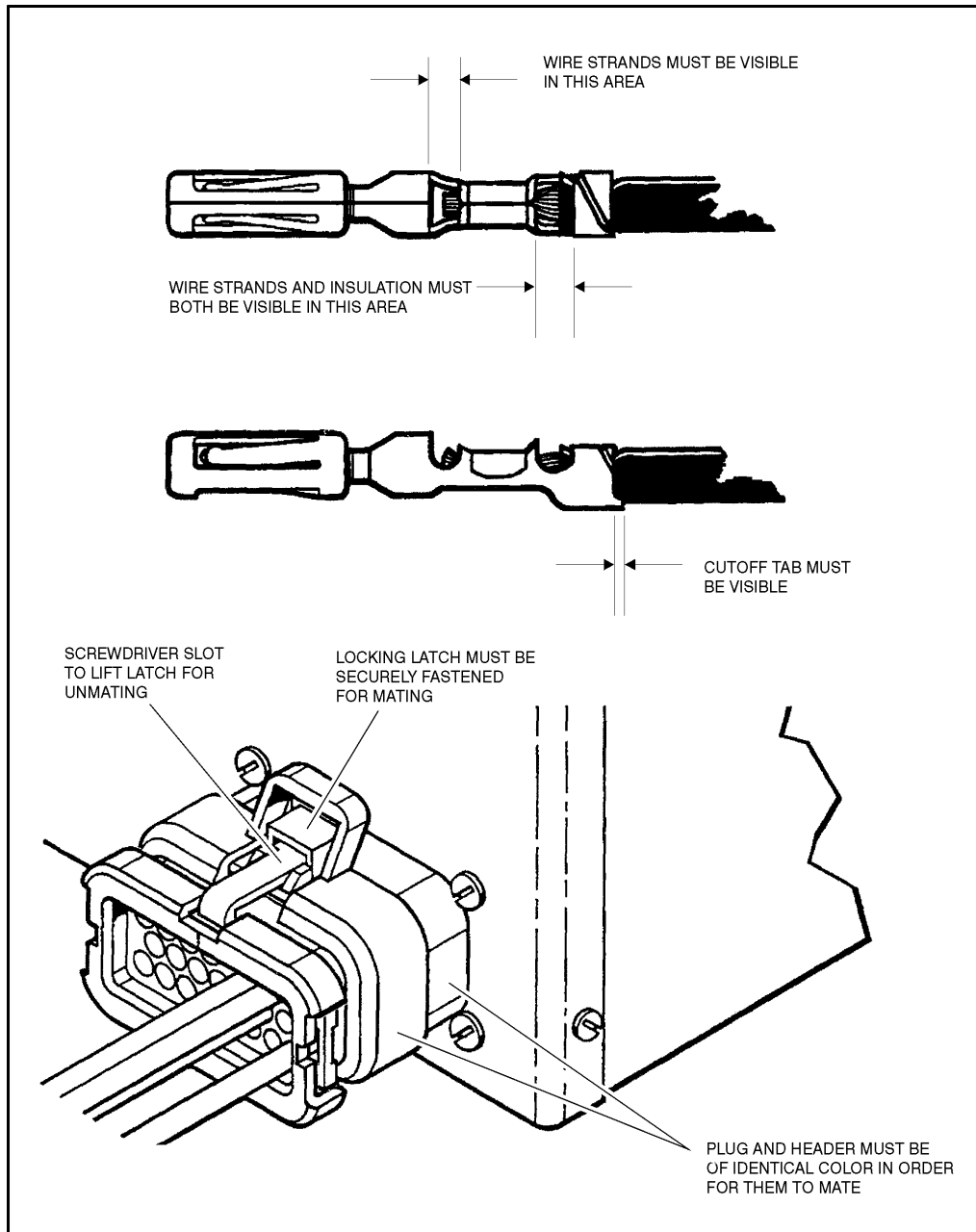

Figure 6-11. Connector Installation

6.4 WORKING WITH DEUTSCH CONNECTORS

DT/DTP Series Assembly

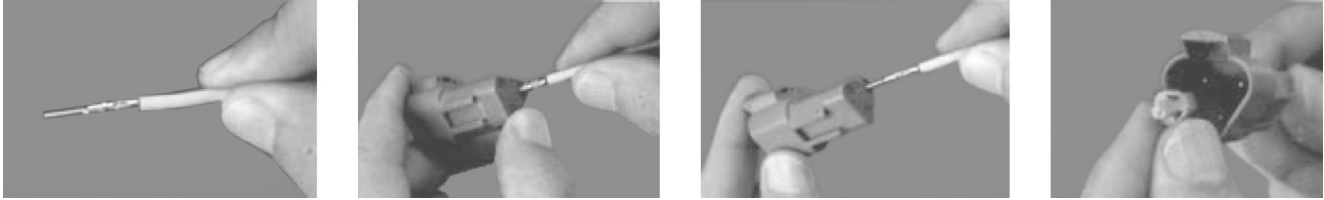

Figure 6-12. DT/DTP Contact Installation

1. Grasp crimped contact about 25mm behind the contact barrel.
2. Hold connector with rear grommet facing you.
3. Push contact straight into connector grommet until a click is felt. A slight tug will confirm that it is properly locked in place.
4. Once all contacts are in place, insert wedgelock with arrow pointing toward exterior locking mechanism. The wedgelock will snap into place. Rectangular wedges are not oriented. They may go in either way.

NOTE: The receptacle is shown - use the same procedure for plug.

DT/DTP Series Disassembly

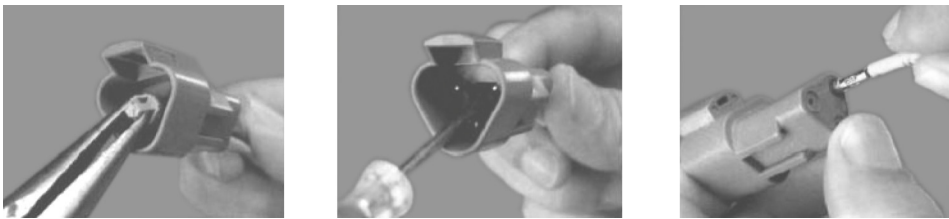

Figure 6-13. DT/DTP Contact Removal

5. Remove wedgelock using needlenose pliers or a hook shaped wire to pull wedge straight out.
6. To remove the contacts, gently pull wire backwards, while at the same time releasing the locking finger by moving it away from the contact with a screwdriver.
7. Hold the rear seal in place, as removing the contact may displace the seal.

HD30/HDP20 Series Assembly



Figure 6-14. HD/HDP Contact Installation

8. Grasp contact about 25mm behind the contact crimp barrel.
9. Hold connector with rear grommet facing you.

10. Push contact straight into connector grommet until a positive stop is felt. A slight tug will confirm that it is properly locked in place.

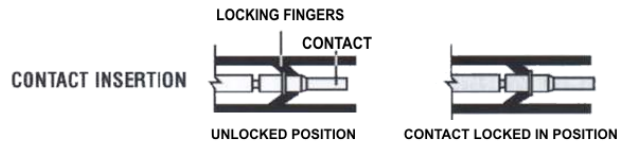

Figure 6-15. HD/HDP Locking Contacts Into Position

NOTE: For unused wire cavities, insert sealing plugs for full environmental sealing

HD30/HDP20 Series Disassembly

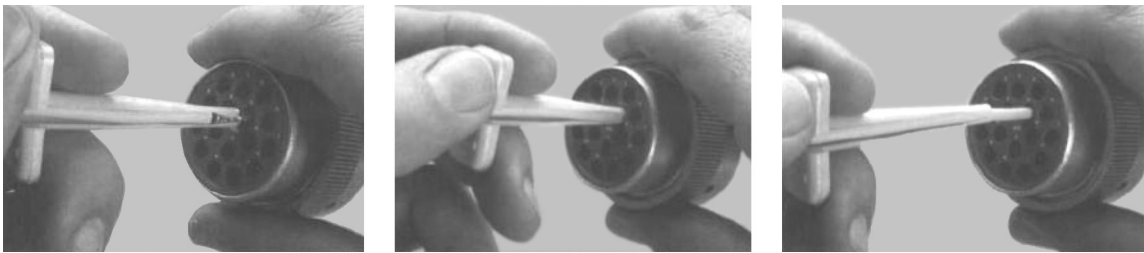

Figure 6-16. HD/HDP Contact Removal

11. With rear insert toward you, snap appropriate size extractor tool over the wire of contact to be removed.
12. Slide tool along into the insert cavity until it engages contact and resistance is felt.
13. Pull contact-wire assembly out of connector.

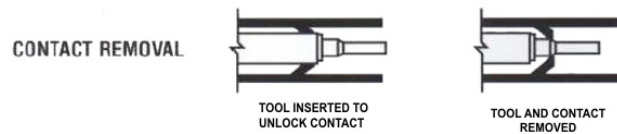

Figure 6-17. HD/HDP Unlocking Contacts

NOTE: Do Not twist or insert tool at an angle.

6.5 SWITCHES

Basic check

The following check determines if the switch is functioning properly, not the circuit in which the switch is placed. A switch is functioning properly when there is continuity between the correct terminals or contacts only when selected.

1. De-energize the circuit.
2. Isolate the switch from the rest of the circuit if possible. If not possible, keep in mind it may affect readings.
3. Access the terminals to the switch.
4. If the switch has two terminals:
 - a. Measure resistance across the terminals.
 - b. Change the switch position.
 - c. Measure resistance again with the leads in the same positions. If the meter was reading short, it should read an open. If the meter was reading open it should read short.
5. If the switch has more than two terminals, consult the schematic or switch diagram to determine what terminals will be connected. The test is similar to testing a switch with two terminals.
 - a. Place one meter lead on the common contact and the other on a different contact in the same circuit.
 - b. Cycle through all positions of the switch. The meter should read short only when the switch connects the two terminals and open otherwise.
 - c. If the switch has more than one common contact repeat the process for that circuit.

Limit Switches

Limit switches are used to control movement or indicate position. Mechanical limit switches are just like manually operated switches except that the moving object operates the switch. These switches can be tested the same way as a standard switch by manually operating the sensing arm.

Another type of limit switch used by JLG is the inductive proximity switch, also referred to as a "prox switch". Inductive proximity switches are actuated only by ferrous metal (metal that contains Iron, such as steel) near the switch. They do not require contact, and must be energized to actuate. These types of switches can be used to detect boom or platform position, for example. These switches have a sensing face where the switch can detect ferrous metal close to it. To find the sensing face, take note how the switch is mounted and how the mechanisms meet the switch. Test this type of switch as follows:

1. Remove prox switch from its mount.
2. Reconnect harness if it was disconnected for step a, and turn on machine.
3. Hold switch away from metal and observe switch state in the control system diagnostics using the Analyzer. See vehicle or control system documentation on how to do this.
4. Place sensing face of switch on the object to be sensed by the switch. If that is not available, use a piece of ferrous metal physically similar to it. The switch state in the control system diagnostics should change.
5. When reinstalling or replacing switch be sure to follow mounting instructions and properly set the gap between the switch and object sensed.

Automatic Switches

If the switch is actuated automatically, by temperature or pressure for example, find a way to manually actuate the switch to test it. Do this either by applying heat or pressure, for example, to the switch. These switches may need to be energized to actuate.

1. Connect instrumentation to monitor and/or control the parameter the switch is measuring.
2. Observe switch state in control system with the Analyzer. See vehicle or control system documentation on how to do this.
3. Operate system such that the switch actuates. This could be going over a certain pressure or temperature, for example. The state indicated in the control system should change.

Switch Wiring - Low Side, High Side

When controlling a load, a switch can be wired between the positive side of the power source and the load. This switch is called a "high side" switch. The switch supplies the power to the load. When a switch is wired between the negative side of the power source and the load, it is a "low side" switch. The switch provides the ground to the load.

A low side switch will allow voltage to be present on the load. No power is applied because the switch is stopping current flow. This voltage can be seen if the measurement is taken with one test lead on the load and the other on the battery negative side or grounded to the vehicle. What is actually being measured is the voltage drop across the switch. This could mislead a technician into thinking the load is receiving power but not operating. To produce an accurate picture of power or voltage applied to the load, measure voltage across the load's power terminals. Also, the technician can measure the voltage at both power terminals with respect to battery ground. The difference between those two measurements is the voltage applied to the load.

6.6 SCHEMATICS

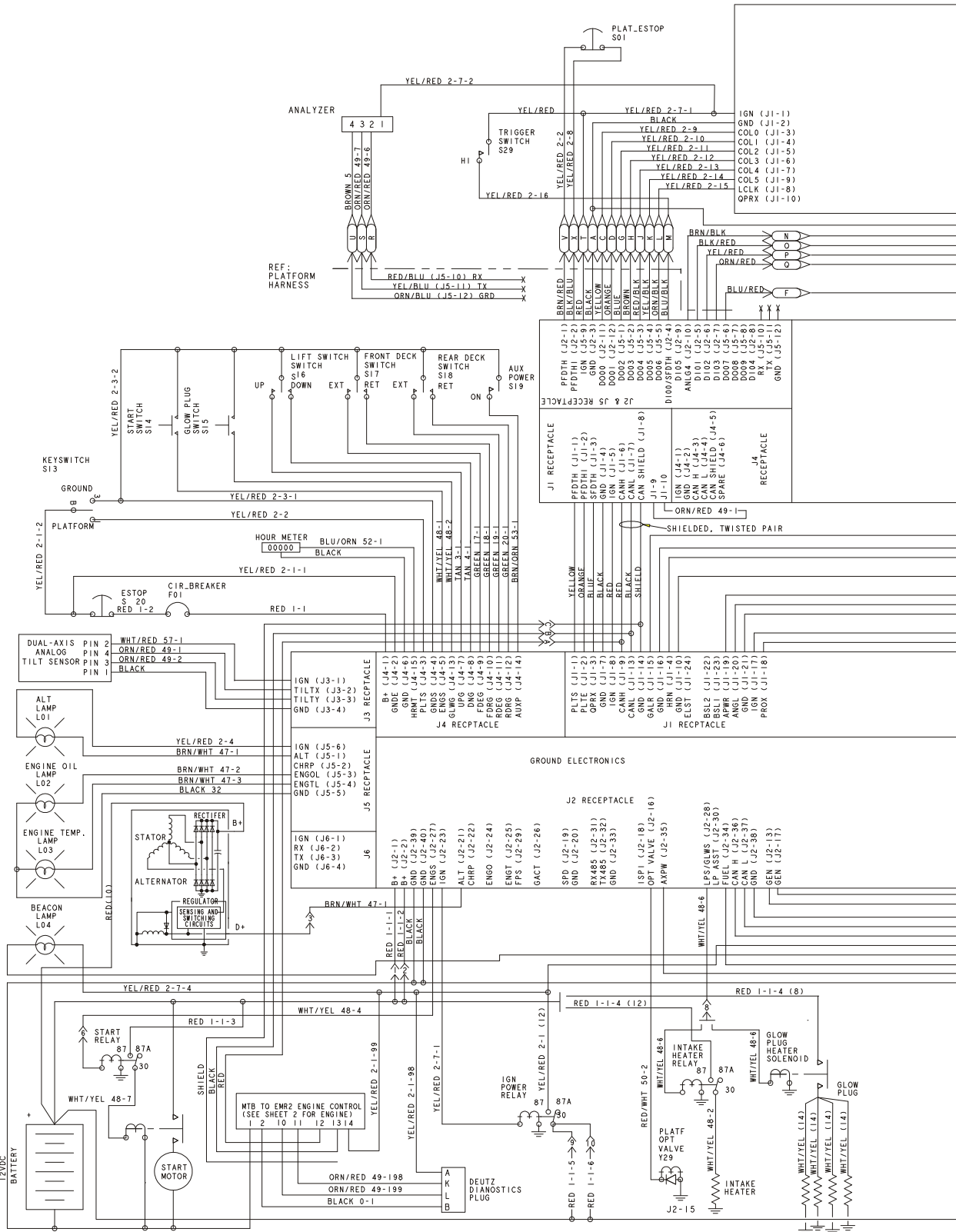

Figure 6-18. Electrical Schematic - Deutz - Sheet 1 of 2

SECTION 6 - GENERAL ELECTRICAL INFORMATION & SCHEMATICS

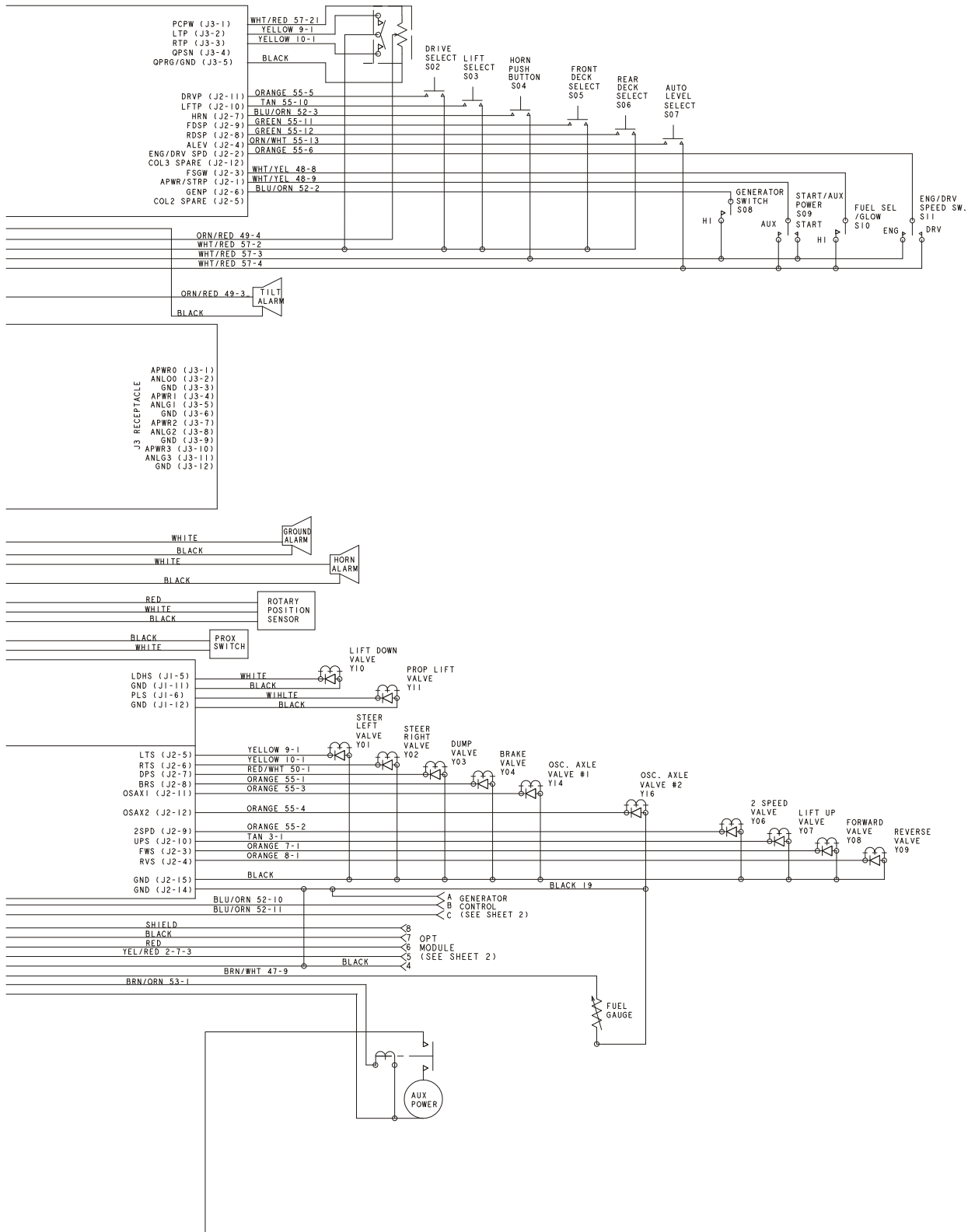

Figure 6-18., Electrical Schematic - Deutz - Sheet 1 of 2

SECTION 6 - GENERAL ELECTRICAL INFORMATION & SCHEMATICS

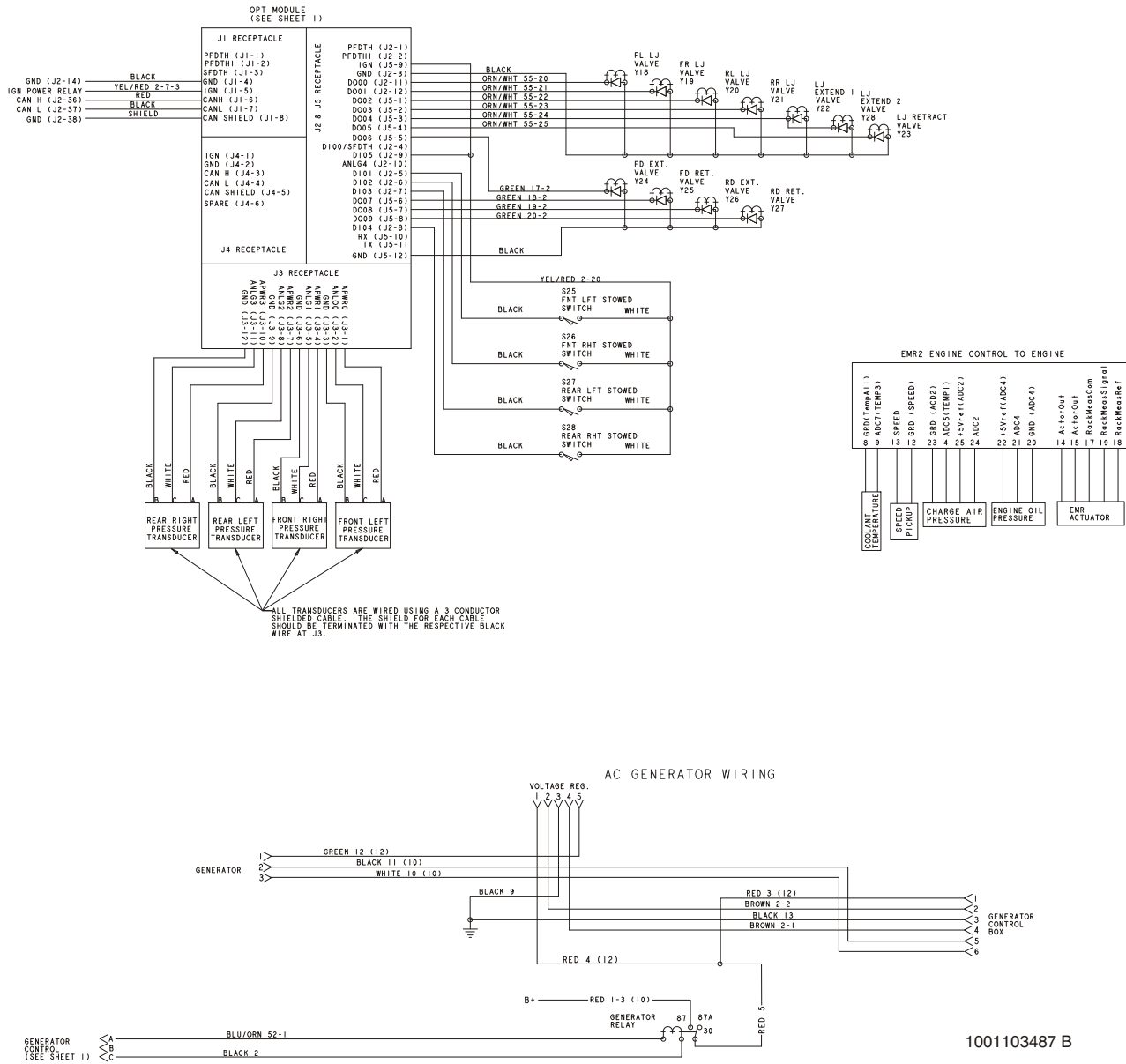

Figure 6-19. Electrical Schematic - Deutz - Sheet 2 of 2

SECTION 6 - GENERAL ELECTRICAL INFORMATION & SCHEMATICS

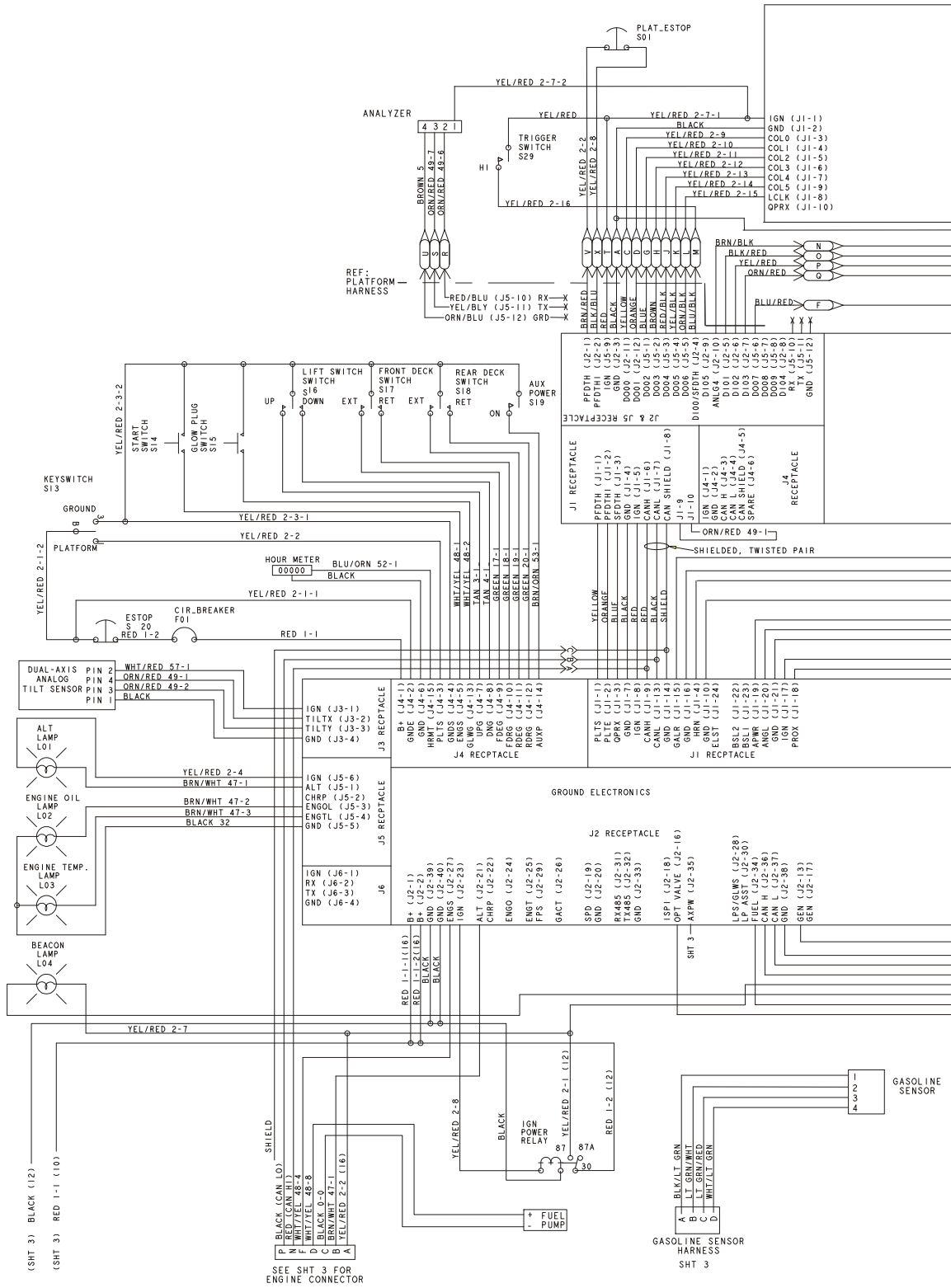

Figure 6-20. Electrical Schematic - GM - Sheet 1 of 3

SECTION 6 - GENERAL ELECTRICAL INFORMATION & SCHEMATICS

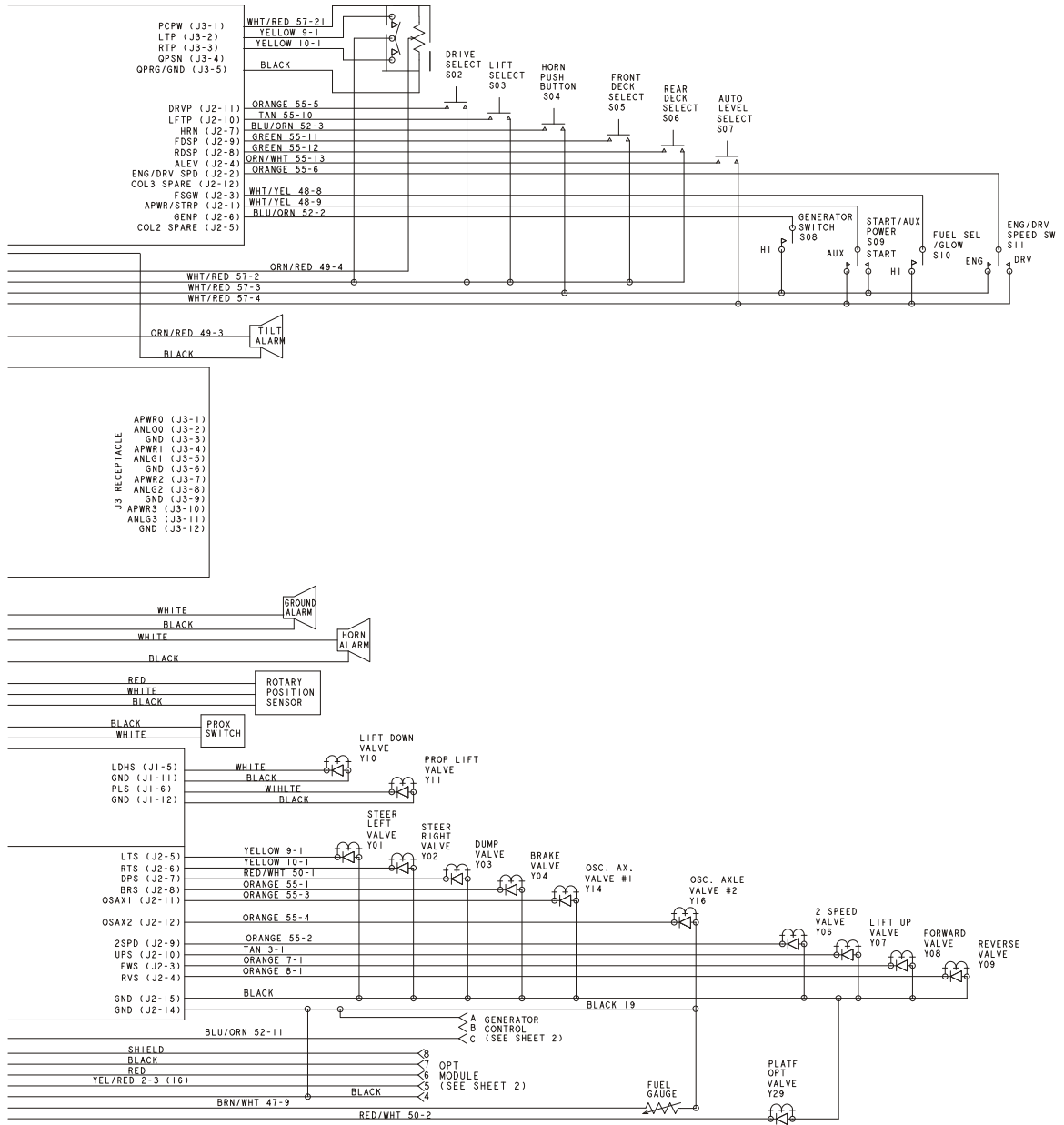
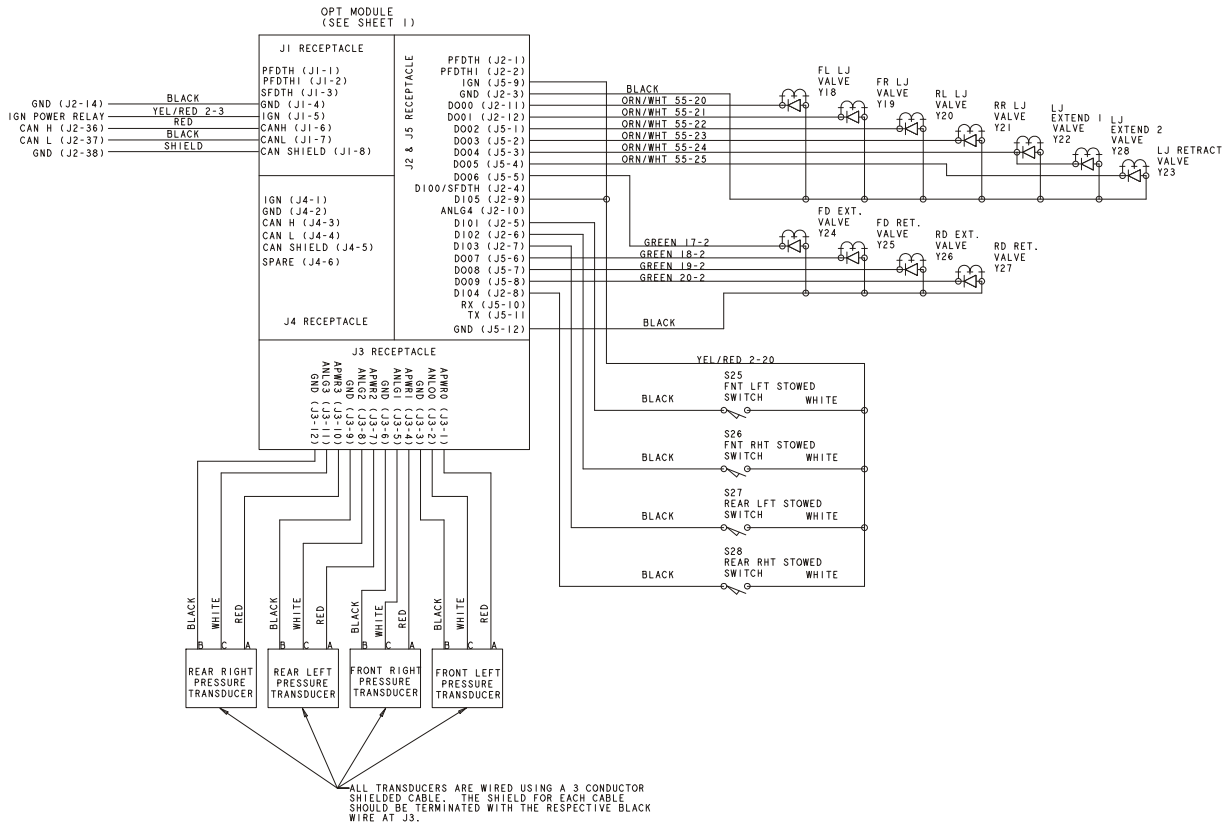

Figure 6-20., Electrical Schematic - GM - Sheet 1 of 3

SECTION 6 - GENERAL ELECTRICAL INFORMATION & SCHEMATICS



AC GENERATOR WIRING

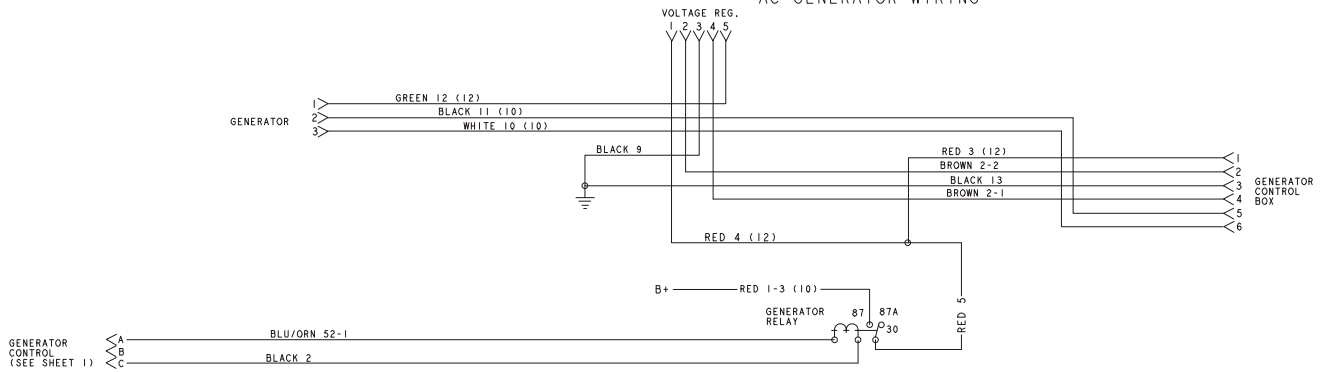

Figure 6-21. Electrical Schematic - GM - Sheet 2 of 3

SECTION 6 - GENERAL ELECTRICAL INFORMATION & SCHEMATICS

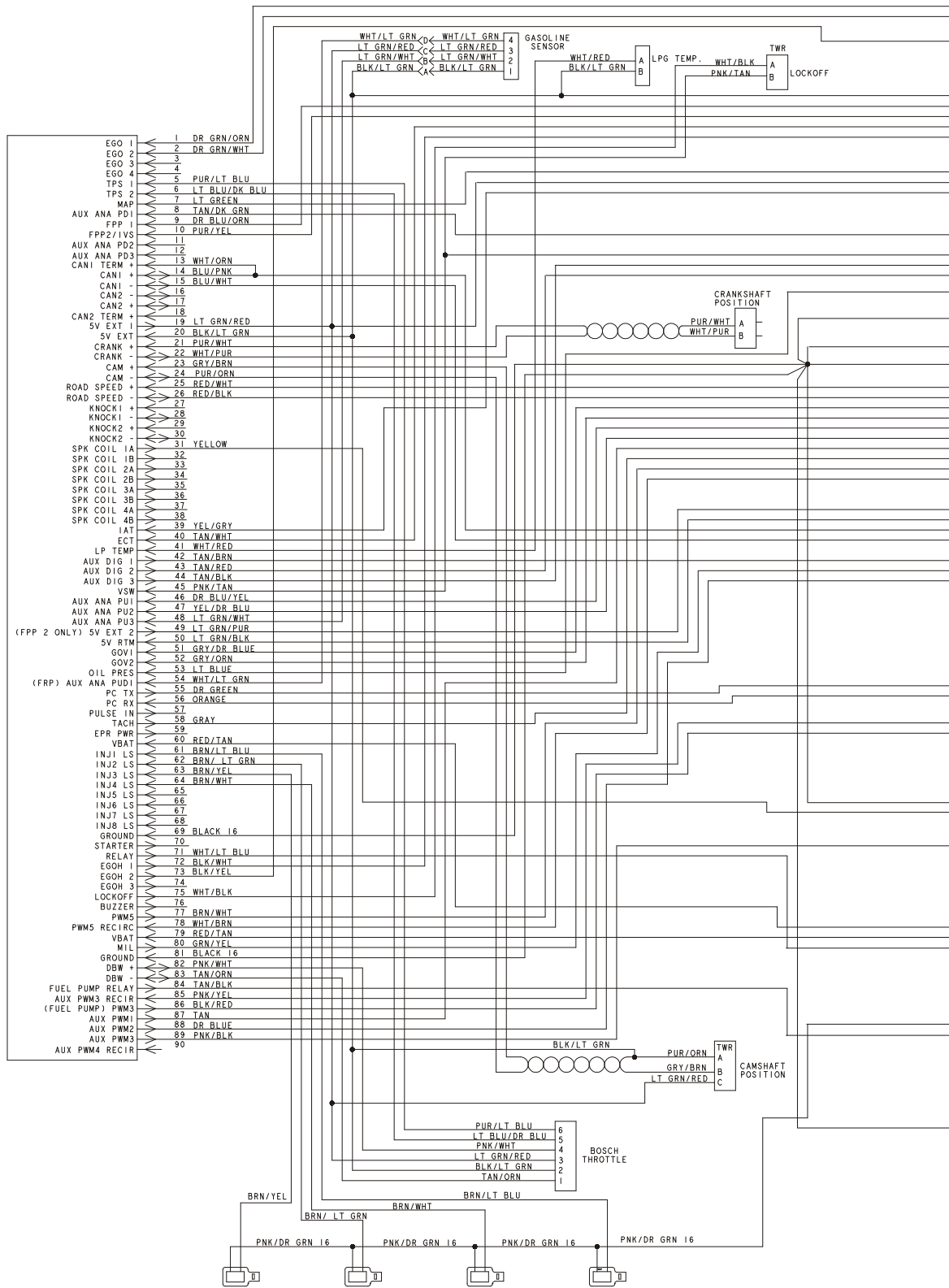
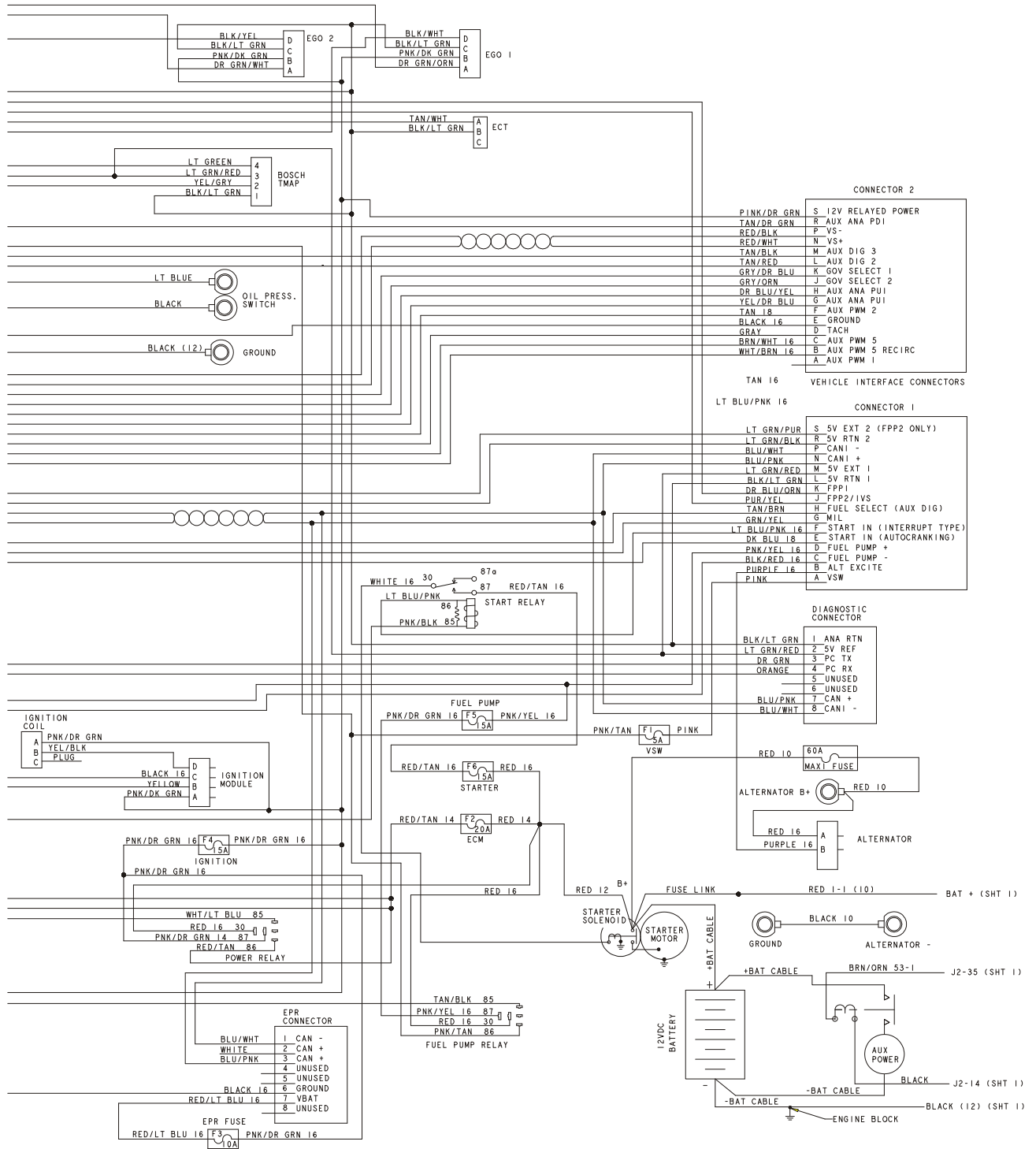

Figure 6-22. Electrical Schematic - GM - Sheet 3 of 3

SECTION 6 - GENERAL ELECTRICAL INFORMATION & SCHEMATICS



1001103488 B

Figure 6-22., Electrical Schematic - GM - Sheet 3 of 3

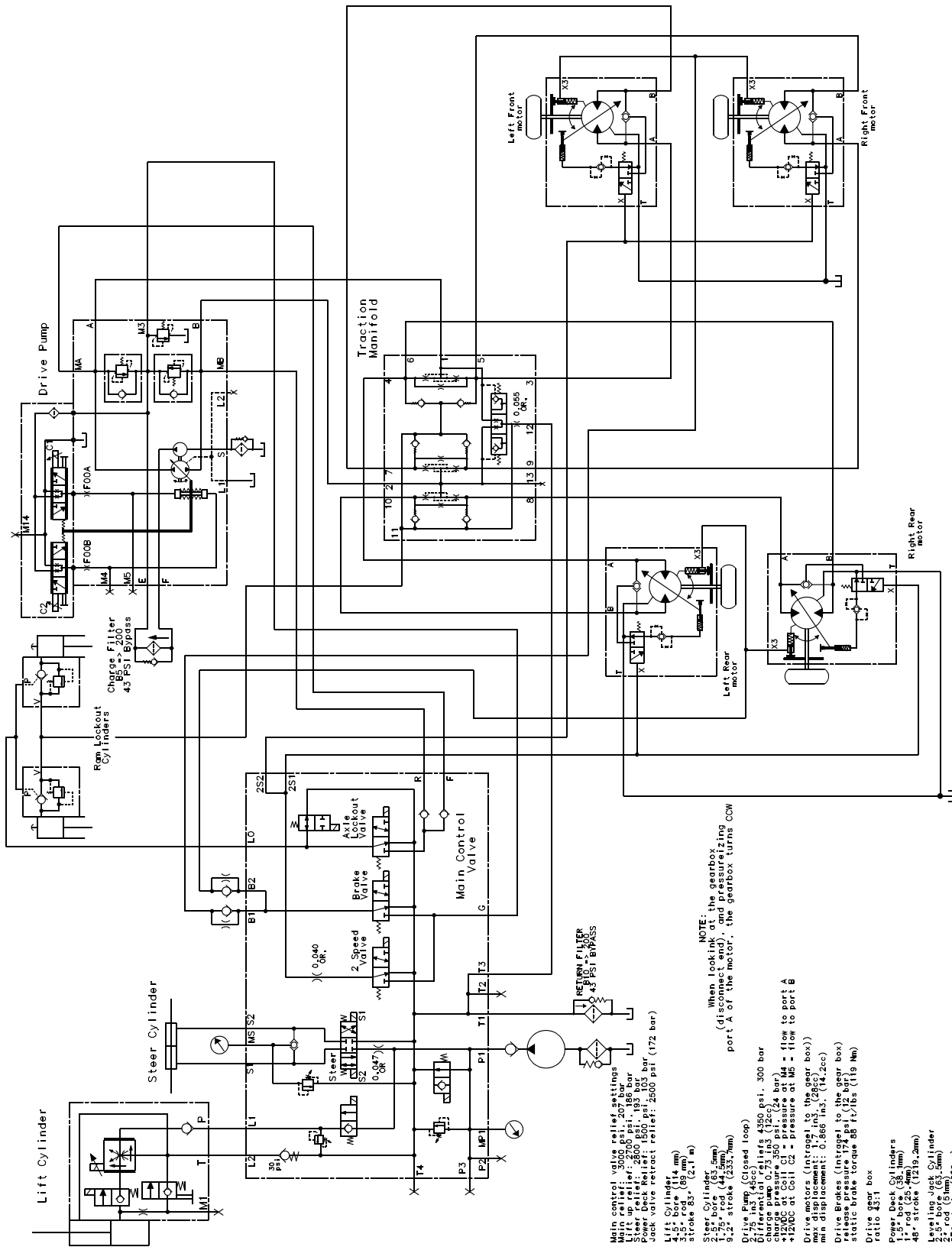

Figure 6-23. Hydraulic Schematic - Sheet 1 of 2

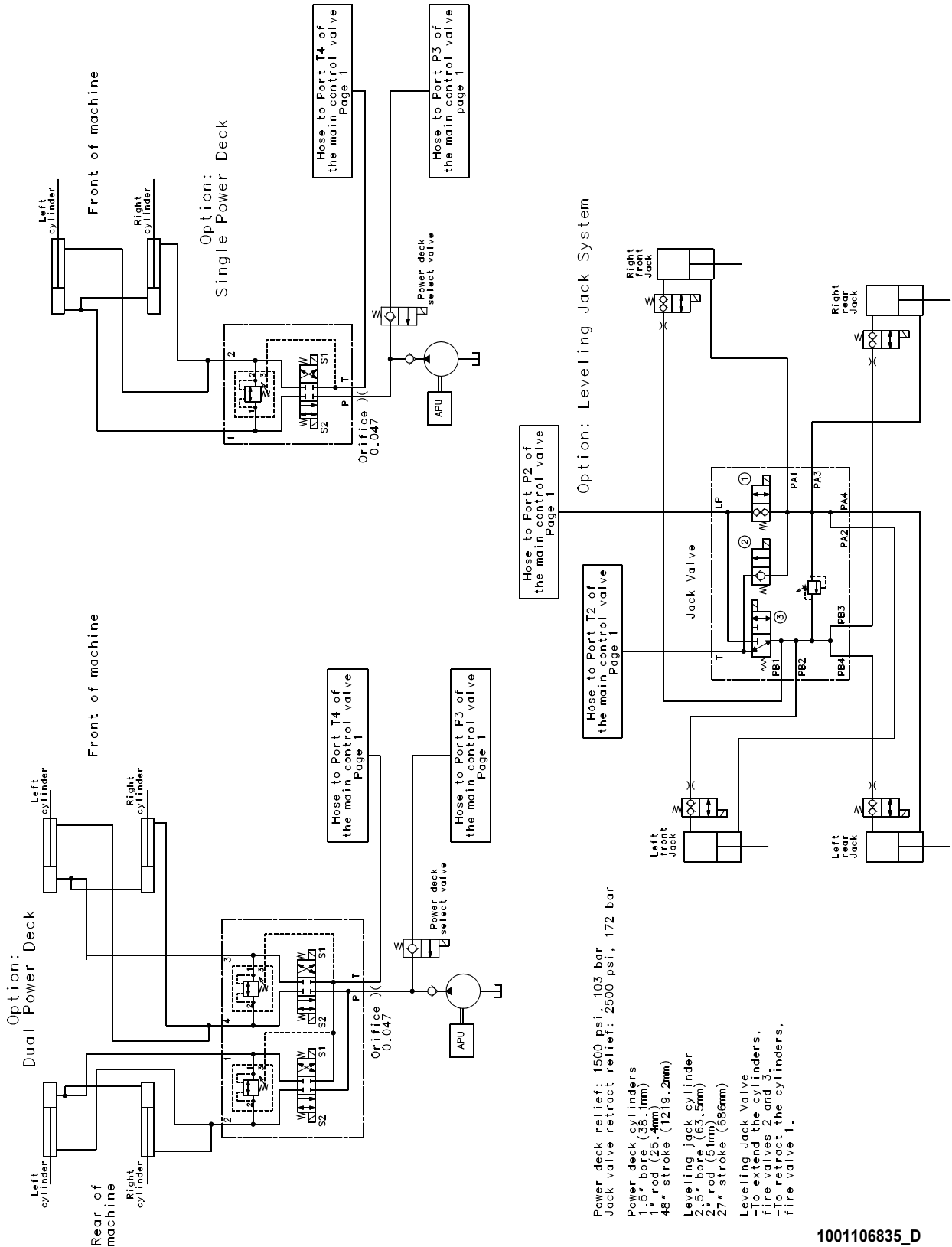

Figure 6-24. Hydraulic Schematic - Sheet 2 of 2

1001106835_D

1001106834_F

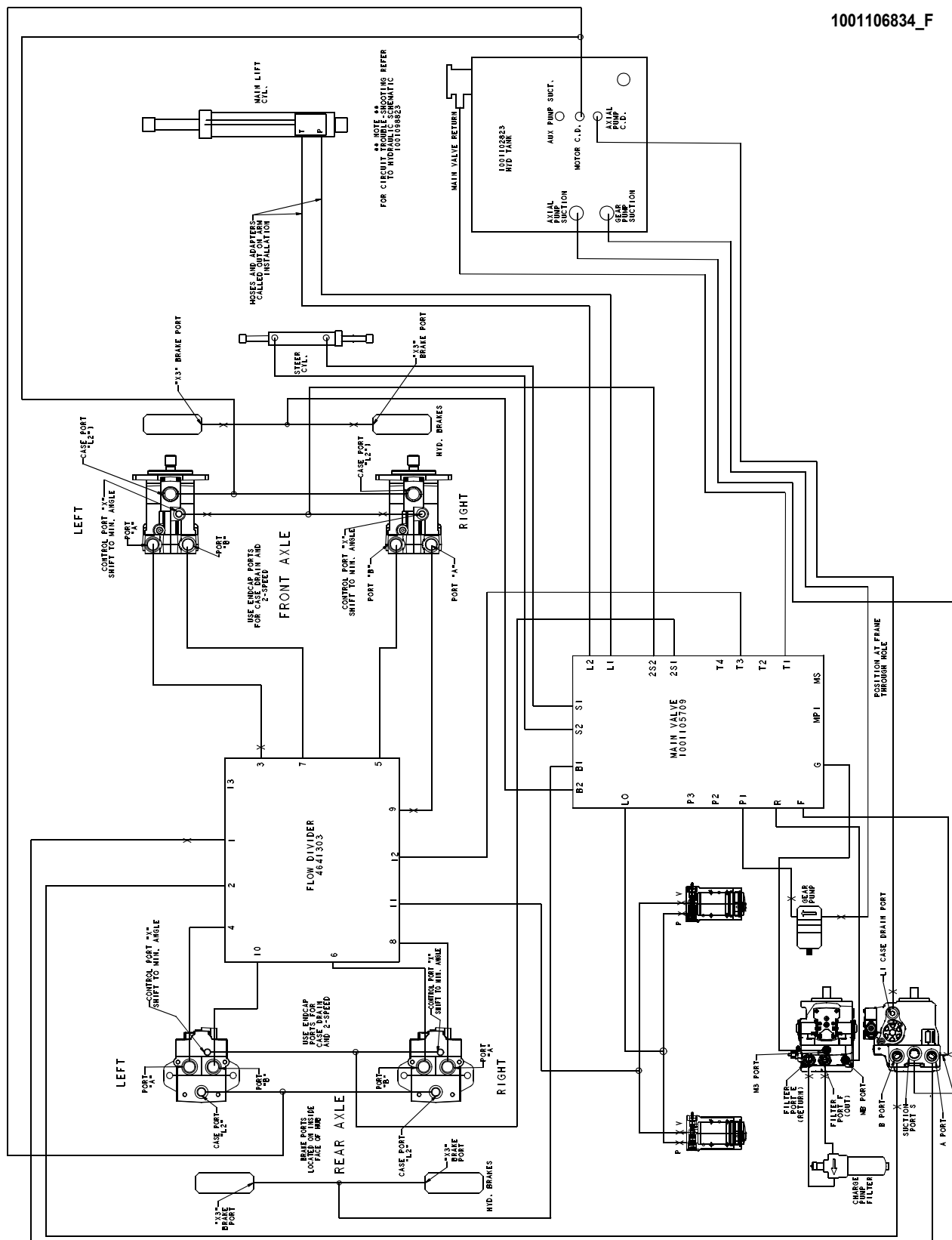

Figure 6-25. Hydraulic Diagram

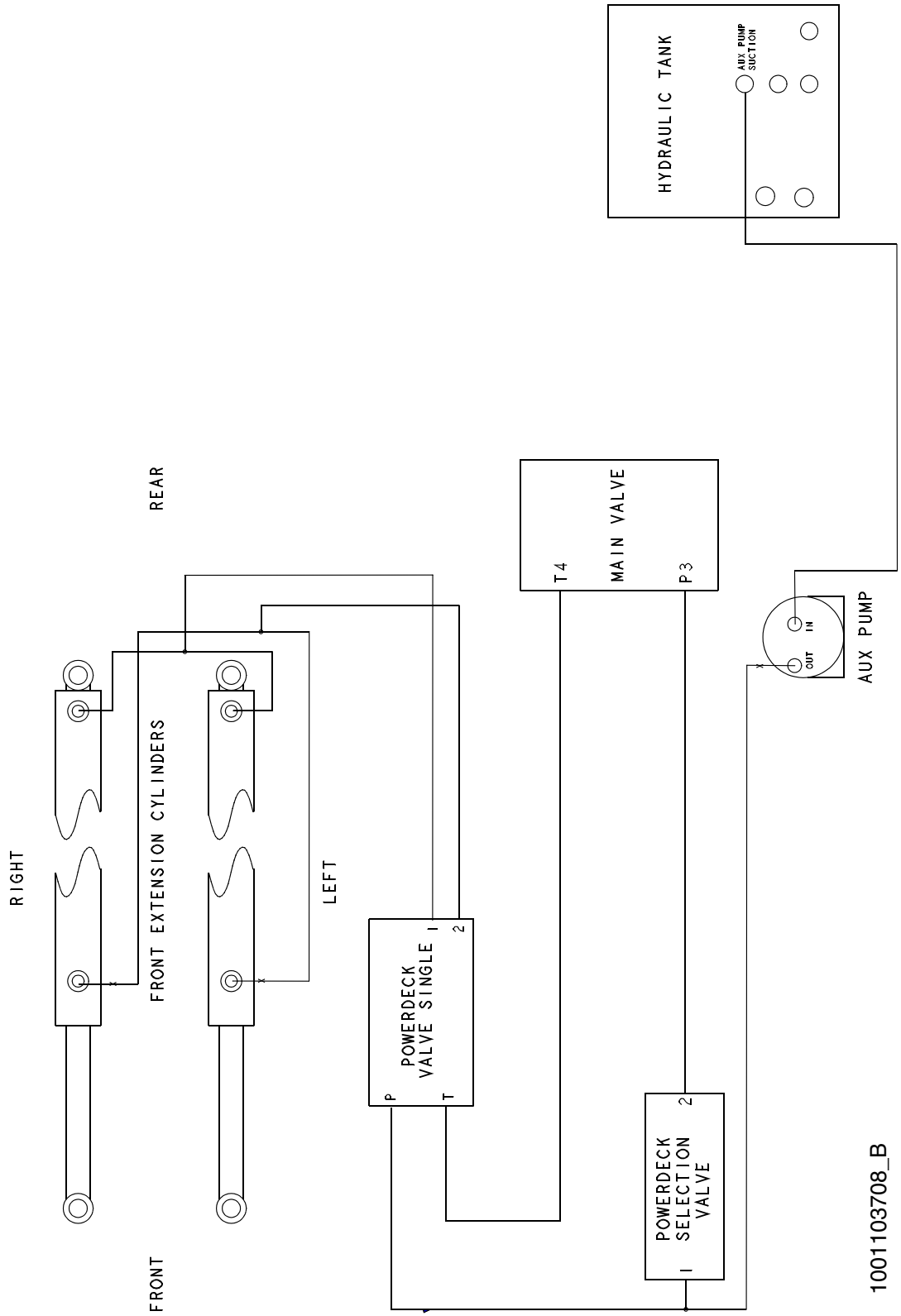
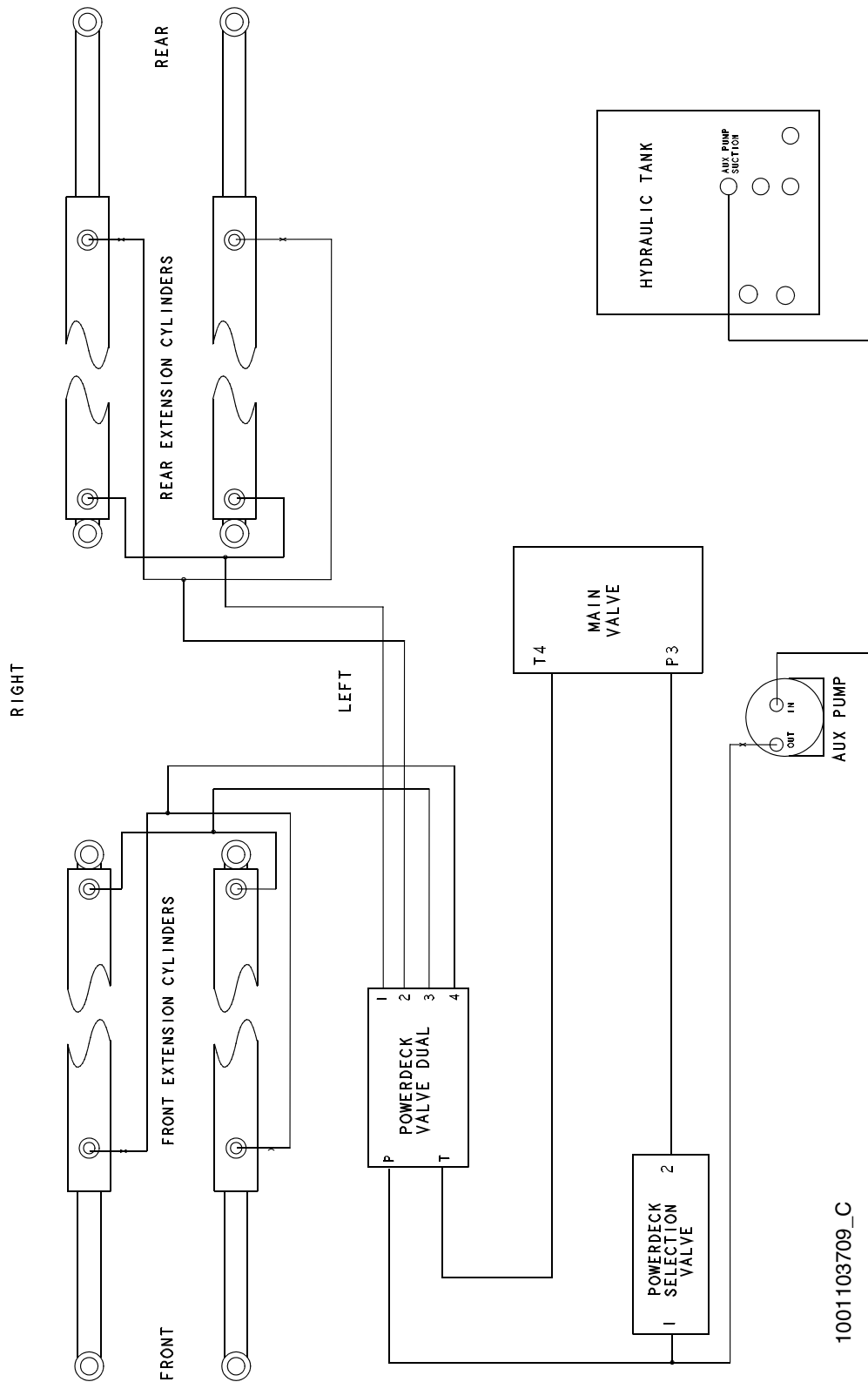
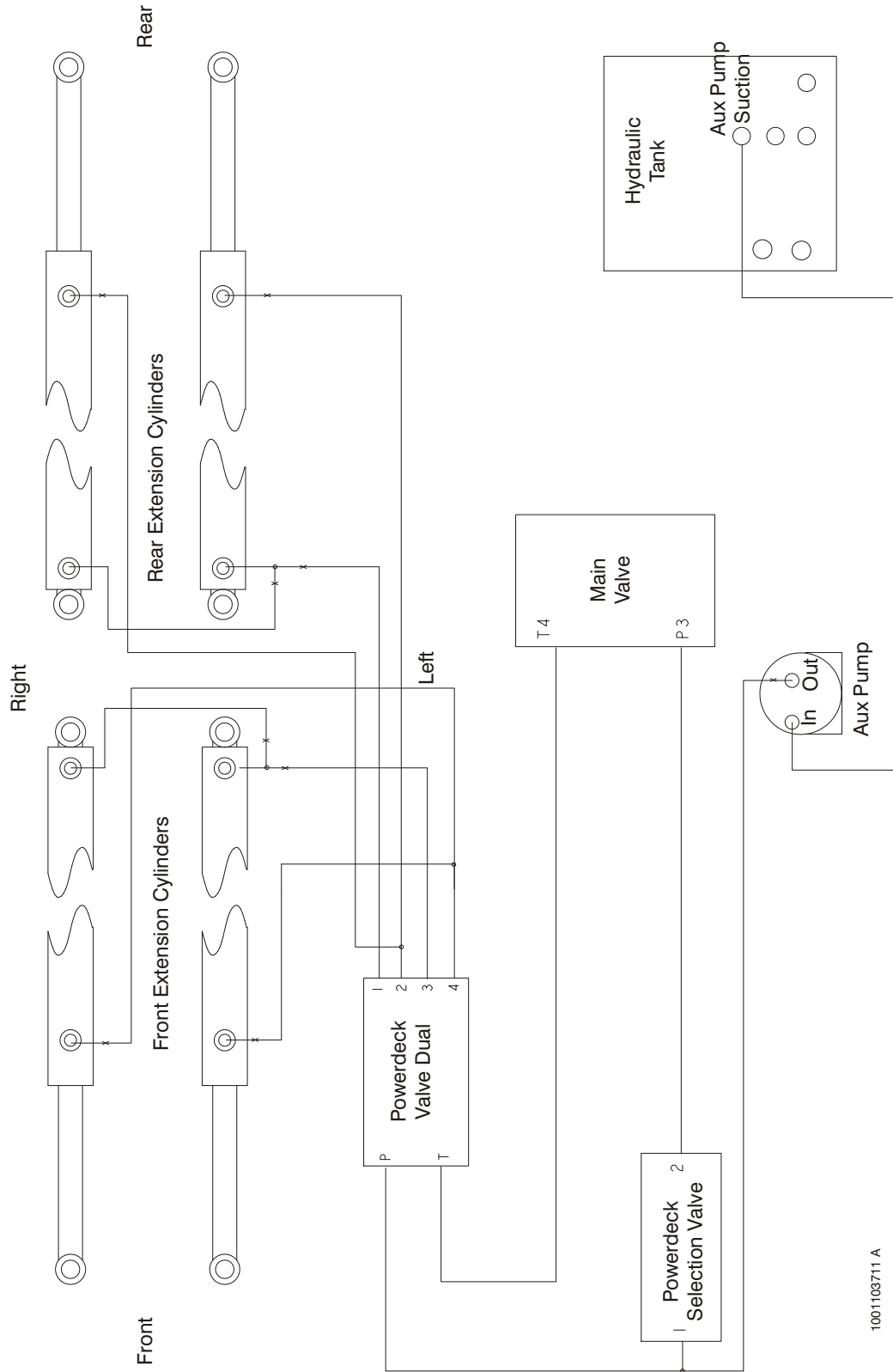

Figure 6-26. Hydraulic Diagram (Powerdeck - Single)



1001103709_C

Figure 6-27. Hydraulic Diagram (Powerdeck - Dual)



1001103711 A

Figure 6-28. Hydraulic Diagram (Powerdeck - Mega)

SECTION 6 - GENERAL ELECTRICAL INFORMATION & SCHEMATICS

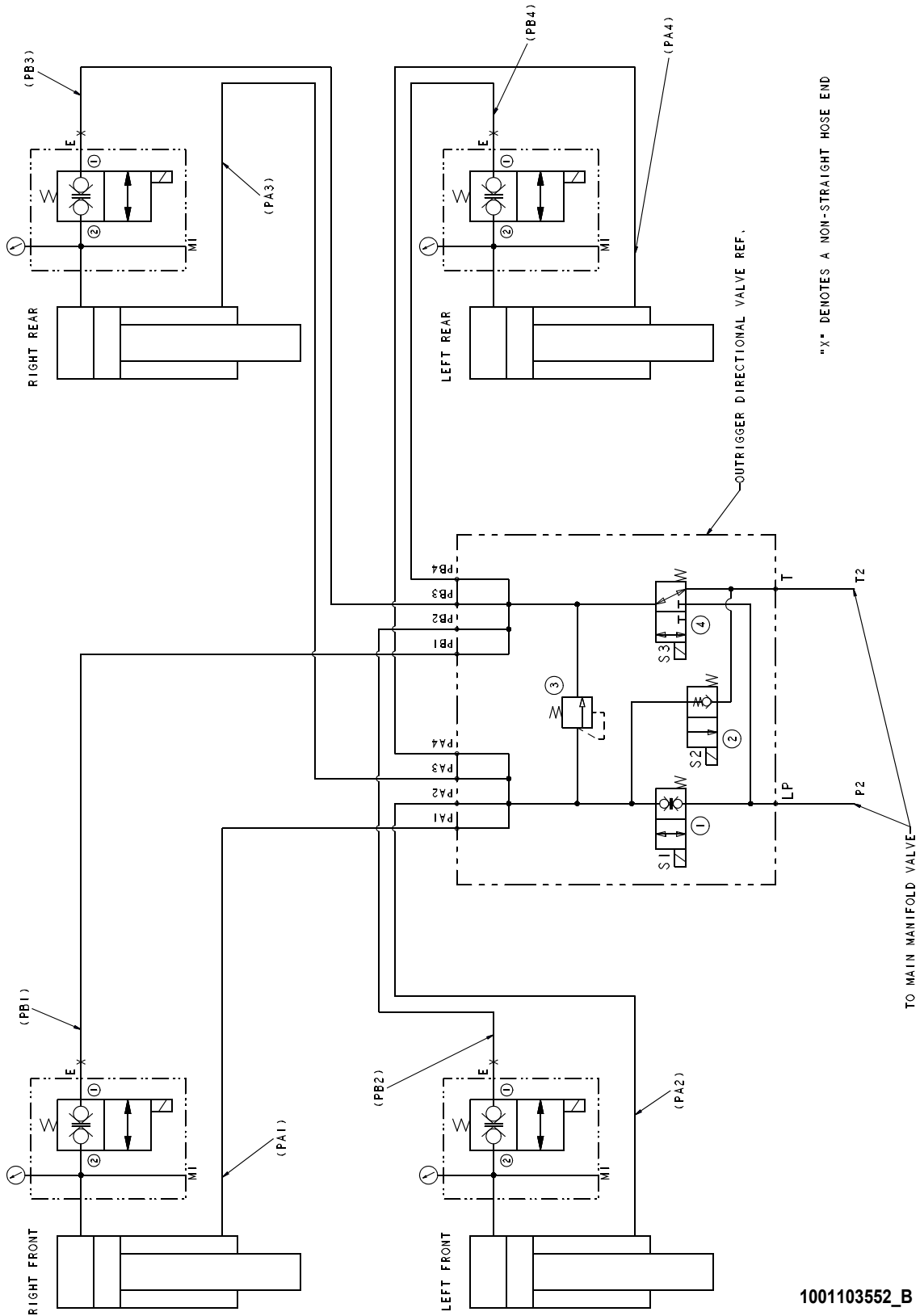

Figure 6-29. Hydraulic Diagram (Leveling Jacks)

1001103552_B



NOTES:

A large area of the page containing two columns of horizontal lines, intended for handwritten notes. Each column contains 20 lines.

SECTION 6 - GENERAL ELECTRICAL INFORMATION & SCHEMATICS

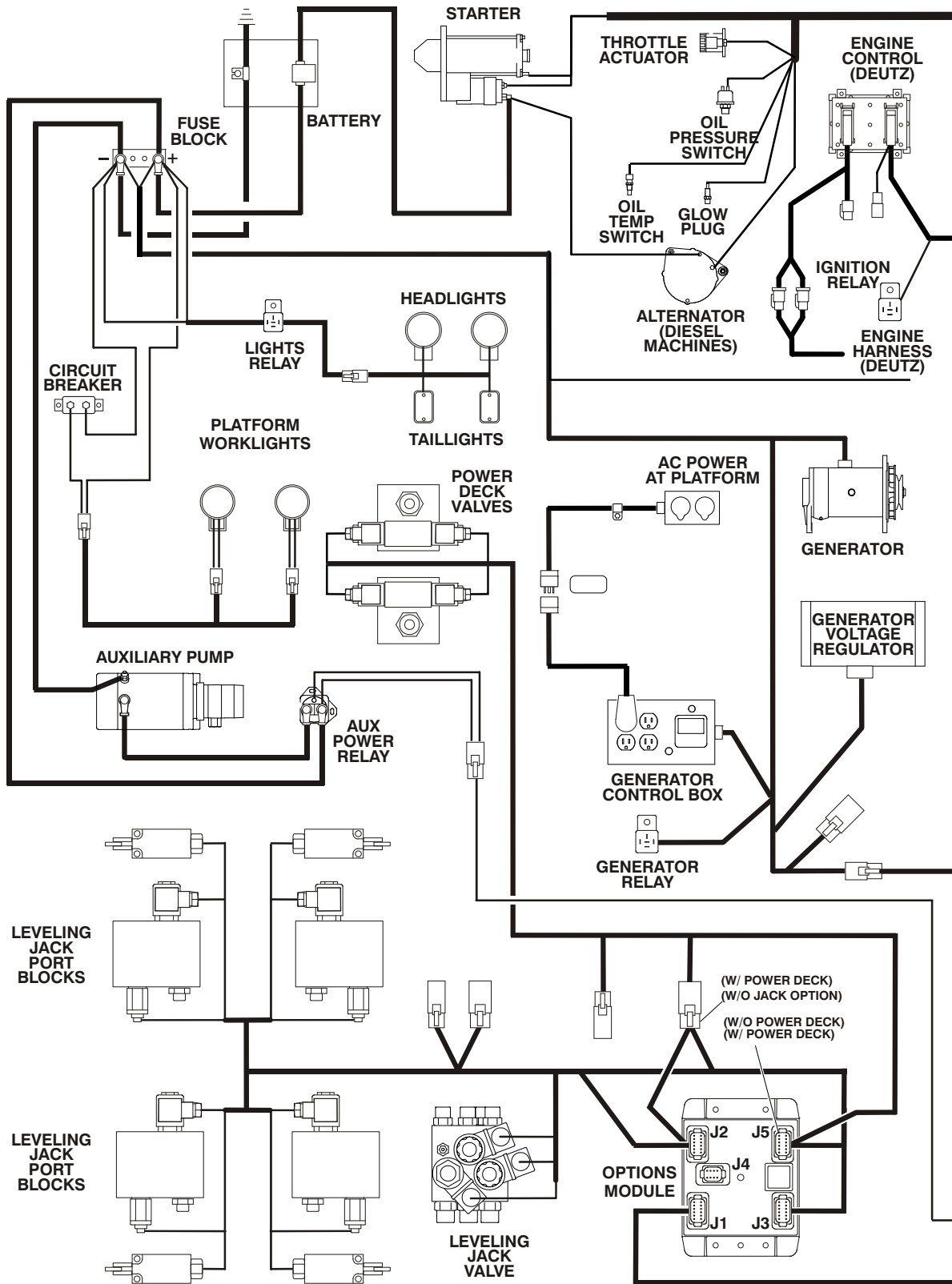

Figure 6-30. Electrical Components Installation - Sheet 1 of 2

SECTION 6 - GENERAL ELECTRICAL INFORMATION & SCHEMATICS

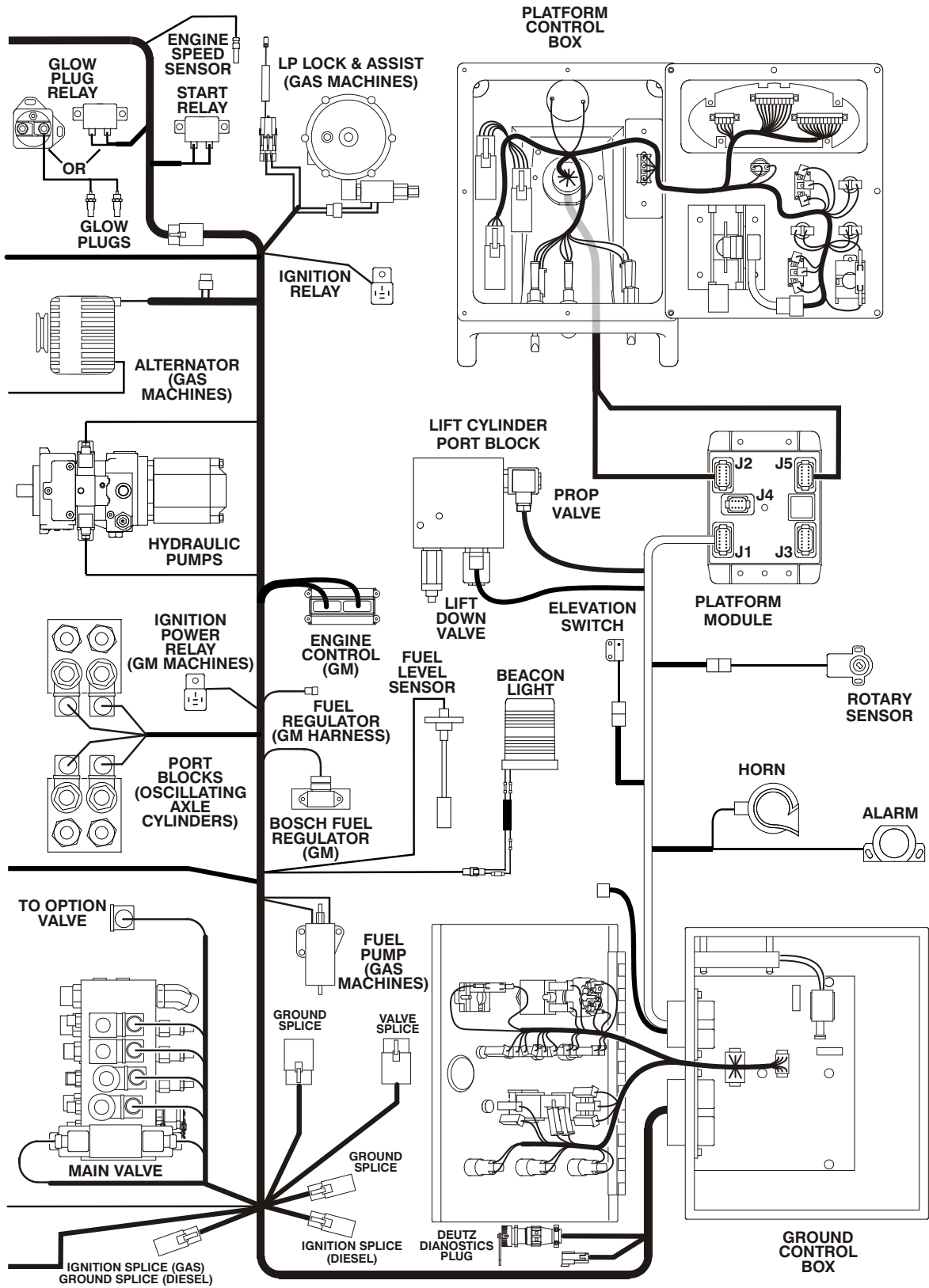

Figure 6-31. Electrical Components Installation - Sheet 2 of 2



3121249



An Oshkosh Corporation Company

Corporate Office
JLG Industries, Inc.
1 JLG Drive
McConnellsburg PA. 17233-9533
USA

☎ (717) 485-5161

☎ (717) 485-6417

JLG Worldwide Locations

JLG Industries (Australia)
P.O. Box 5119
11 Bolwarra Road
Port Macquarie
N.S.W. 2444
Australia
☎ +61 2 65 811111
☎ +61 2 65 810122

JLG Latino Americana Ltda.
Rua Eng. Carlos Stevenson,
80-Suite 71
13092-310 Campinas-SP
Brazil
☎ +55 19 3295 0407
☎ +55 19 3295 1025

JLG Industries (UK) Ltd
Bentley House
Bentley Avenue
Middleton
Greater Manchester
M24 2GP - England
☎ +44 (0)161 654 1000
☎ +44 (0)161 654 1001

JLG France SAS
Z.I. de Baulieu
47400 Fauillet
France
☎ +33 (0)5 53 88 31 70
☎ +33 (0)5 53 88 31 79

JLG Deutschland GmbH
Max-Planck-Str. 21
D - 27721 Ritterhude - Ihlpohl
Germany
☎ +49 (0)421 69 350 20
☎ +49 (0)421 69 350 45

JLG Equipment Services Ltd.
Rm 1107 Landmark North
39 Lung Sum Avenue
Sheung Shui N. T.
Hong Kong
☎ (852) 2639 5783
☎ (852) 2639 5797

JLG Industries (Italia) s.r.l.
Via Po. 22
20010 Pregnana Milanese - MI
Italy
☎ +39 029 359 5210
☎ +39 029 359 5845

Oshkosh-JLG Singapore
Technology Equipment Pte Ltd.
29 Tuas Ave 4
Jurong Industrial Estate
639379 - Singapore
☎ +65-6591-9030
☎ +65-6591-9031

Plataformas Elevadoras
JLG Iberica, S.L.
Trapadella, 2
P.I. Castellbisbal Sur
08755 Castellbisbal,
Barcelona
Spain
☎ +34 93 772 4700
☎ +34 93 771 1762

JLG Sverige AB
Enkopingsvagen 150
Box 704
SE - 176 27 Jarfalla
Sweden
☎ +46 (0)850 659 500
☎ +46 (0)850 659 534