



Service and Maintenance Illustrated Parts Manual

Models
6308AN

1730961

September 09, 2020



Quality
Endorsed
Company

ISO 9001 Lic 6080



CONTENTS

Section One	Service and Maintenance
Section Two	Illustrated Parts
Section Three	Recommended Spares Quick Reference

Customer Support

JLG Industries (Port Macquarie)
11 Bolwarra Road
PORT MACQUARIE NSW 2444
Phone: (02) 6581 1111

JLG Industries (Victoria)
30-32 Cyber Loop
Dandenong VIC 3175
Phone: (03) 9554 4333

JLG Industries (Queensland)
223 Fison Avenue West
Eagle Farm QLD 4009
Phone: (07) 3309 9111

JLG Industries (Western Australia)
39 Kewdale Road
Kewdale, PERTH WA 6105
Phone: (08) 9356 9811

JLG Industries (NSW)
358 Park Road
REGENTS PARK NSW 2143
Phone: (02) 8718 6300

JLG Industries (SA)
8 Nucera Court
Greenfields SA 5107
Phone: (08) 82598777

JLG Industries (New Zealand)
2b Fisher Crescent
Mt Wellington, Auckland
New Zealand
Phone: + 64 9276 1728

SECTION TWO

SERVICE AND MAINTENANCE

CONTENTS:

	Page
• SAFETY PRECAUTIONS	2-2
• SPECIFICATIONS	2-4
• PRODUCT DESCRIPTION	2-5
• MAINTENANCE PROCEDURES	2-8
➤ Changing engine oil	2-10
➤ Floodlight lamp change	2-10
➤ Removing floodlight assembly	2-11
➤ Removing mast assembly	2-12
➤ Replacement of AC circuit breakers	2-12
➤ Remove/replace lamp ballasts.	2-13
➤ Setting hydraulic pressure	2-14
• FAULT DIAGNOSIS CHART	2-15
➤ Lights generator circuit	2-15
➤ Engine	2-16
➤ Electrical Safety Tests	2-17
• MAINTENANCE SCHEDULE	2-19
• HYDRAULIC SCHEMATIC DIAGRAM	2-20
• ELECTRICAL SCHEMATIC DIAGRAM	
➤ AC System	2-21
➤ DC System	2-22

SAFETY ALERT SYMBOLS AND SAFETY SIGNAL WORDS



This is the Safety Alert Symbol. It is used to alert you to the potential personal injury hazards. Obey all safety messages that follow this symbol to avoid possible injury or death.

! DANGER

INDICATES AN IMMINENTLY HAZARDOUS SITUATION. IF NOT AVOIDED, WILL RESULT IN SERIOUS INJURY OR DEATH. THIS DECAL WILL HAVE A RED BACKGROUND.

! WARNING

INDICATES A POTENTIALLY HAZARDOUS SITUATION. IF NOT AVOIDED, COULD RESULT IN SERIOUS INJURY OR DEATH. THIS DECAL WILL HAVE AN ORANGE BACKGROUND.

! CAUTION

INDICATES A POTENTIALLY HAZARDOUS SITUATION. IF NOT AVOIDED, MAY RESULT IN MINOR OR MODERATE INJURY. IT MAY ALSO ALERT AGAINST UNSAFE PRACTICES. THIS DECAL WILL HAVE A YELLOW BACKGROUND.

IMPORTANT

INDICATES PROCEDURES ESSENTIAL FOR SAFE OPERATION. THIS DECAL WILL HAVE A GREEN BACKGROUND.

SAFETY PRECAUTIONS

Throughout the service and maintenance section of this manual cautions and warnings are shown in **BOLD TYPE**. These outline where special care is required when undertaking the various procedures outlined.

⚠ CAUTION

WHEN AN ABNORMAL CONDITION IS NOTED WITH THE MACHINE AND THE PROCEDURES WITHIN THIS MANUAL DO NOT COVER THE CONDITION, WORK SHOULD BE STOPPED UNTIL TECHNICALLY QUALIFIED GUIDANCE CAN BE CONSULTED.

- Modifications or alterations to the lighting tower are not permitted without the prior written permission of the manufacturer.
- Failure to comply with the safety precautions listed here and elsewhere in the manual may result in severe injury or death.
- When handling the lighting tower other than towing for the purposes of lifting or manoeuvring, there are forklift pockets provided at the rear of the machine and 4 lifting points provided on the main frame for lifting by a crane. Ensure that the forklift or crane is of suitable capacity prior to attempting the lift. Refer to the diagrams shown elsewhere in this manual for correct handling procedures using a crane and forklift.

HYDRAULIC SYSTEM

The lighting tower incorporates a hydraulic system for the purpose of operating the mast functions. Dangerous hydraulic pressures are created by this system. All applicable safety precautions should be taken when working on the hydraulic system.

⚠ WARNING

SHUTDOWN THE MACHINE PRIOR TO DISCONNECTING HYDRAULIC LINES. ENSURE THE MACHINE IS SAFELY SUPPORTED PRIOR TO REMOVAL OF HYDRAULIC LINES, CYLINDERS ETC.

ELECTRICAL SYSTEM

⚠ WARNING

THE LIGHTING TOWER INCORPORATES AN ELECTRICAL SYSTEM WHICH GENERATES VOLTAGES IN EXCESS OF 500 VOLTS AC.

SEVERE INJURY OR DEATH MAY RESULT IF WORK IS UNDERTAKEN BY UNTRAINED AND UNQUALIFIED PERSONNEL.

ALL SAFETY PRECAUTIONS SHOULD BE UNDERTAKEN WHEN WORKING ON THE MACHINE.

SHUTDOWN THE MACHINE PRIOR TO DISCONNECTING ELECTRICAL WIRING.

⚠ DANGER

DANGEROUS VOLTAGES MAY BE PRESENT EVEN WHEN POWER IS OFF.

SAFETY PRECAUTIONS**SHUTDOWN ENGINE**

Shutdown engine, switch off all circuit breakers and allow 10-minutes for ballast capacitors to discharge before replacing lamps. Check capacitors are below 10VDC before service to lamp sockets or ballast circuits by trained service personnel only.

SPECIFICATIONS**1.1 CAPACITIES**

	D1403	403D-11
Hydraulic Oil Tank	5.6L	5.6L
Fuel Tank	167L	167L
Engine Crank Case	7.0L	4.9L
Radiator	4.2L	4.2L

1.2 COMPONENT DATA**Engine****Kubota D1403BG**

3 Cylinder, water-cooled
 Rated Power 14.3 h.p.
 SAE nett @1500 rpm (10.7 kW)

Perkins 403D-11

3 cylinder, water-cooled
 Rated Power 11.5 h.p @1500 rpm
 (8.6 kW)

Alternator**Syncro**

Model HB45AR
 Rated Power 14 kVA (opt 16kVA)
 Configuration 3-phase.

Leroy Somer

Model LSA 37M7J ¼
 Rated Power 13 kVA.
 Configuration 3-phase

Hydraulics – Fenner Fluid Power

Motor 12 Volt D.C.
 Operating Pressure 2500 psi
 17.23 MPa
 Pump Volume 0.8 cubic cm

Flood-Lights (Sylvania)

Metal Halide HID 1500 W
 or
 HP Sodium Vapour 1000 W

Electrical Controls

R.C.D. trip rating 30 mA
 Lamp Switches/
 Circuit breakers 10 A

Axle

Single Axle (IRS) Independent Rubber Suspension.

Brakes

Hydraulic overriding. Drum.

Tyres

Dimensions 205/80 x 16"

Wheels

Dimensions 16" x 6J
 wheel nuts ½"UNF
 nut tightening torque 125 Nm

Battery

Model N70ZZ Marine
 Voltage 12 V D.C.
 C.C.A. 600 A
 Reserve Current 130 A

1.3 DIMENSIONS

Length (Drawbar Stowed) 2.5 m
 Width 1.74 m
 Height Stowed 2.4 m
 Height Erected 8 m

1.4 WEIGHT

aggregate trailer mass 1700 kg
 towball weight 80 kg

1.5 PERFORMANCE

Mast lift time 110 s
 Mast Lower time 90 s
 Rated Towing Speed 80 km/hr
 Fuel Consumption
 Perkins & Kubota engine 2.6 L/hr

1.6 PRESSURE SETTINGS

System Pressure 2500 psi 172.3 bar

PRODUCT DESCRIPTION

PRODUCT DESCRIPTION

The model 6308AN Lighting Tower is an ultra compact unit designed for maximum performance incorporating all the features of an advanced design while maintaining a compact overall size.

Its unique mast design allows for maximum height while still maintaining a compact stowed profile. The Tower's short length allows for "across the tray" stowing on trucks which allows for a greater number of units to be carried on an 8 foot wide truck tray.

The unit is powered by a Kubota 3 cylinder water cooled diesel engine coupled to a three phase star configured self regulating alternator.

Four 1500 watt metal halide or high-pressure sodium vapour flood-lights provide a wide light dispersion while maintaining a compact overall size for minimum sail area and maximum stability in high winds.

Mast Operation

The unique mast design allows for a working height of 8m. It is actuated by a single lift cylinder for the raise lower function. In addition, the upper section has a double acting cylinder for the telescope function. The four lamps are mounted on a light bar assembly which has a single double acting cylinder for tilting the complete assembly. This function aids in the directional control of the light array together with providing adjustment when the mast is lowered for compact storage.

Three lever type hydraulic valve controls are provided for the operation

of the three mast functions of lift up, telescope, tilt.

A manual mast rotation system is employed with locking mechanism to allow for easy light positioning through 350 degrees of operation.

Frame

The light tower unit is constructed on a fully welded robust steel chassis.

Two large gas strut assisted doors swing up to provide access to all internal components for service and maintenance.

An additional small door is provided on the left side of the machine to access both the electrical and hydraulic function controls.

An Independent Rubber Suspension (IRS) axle is fitted to the machine providing a smoother ride with minimal maintenance and optimum towing stability. Hydraulic override brakes are fitted for good stopping performance and a park brake is fitted for secure stowage of the machine.

Stability of the machine is provided by four outrigger legs stowed integrally on the machine.

Three pull out legs are provided at the rear, each with a wind down jack mechanism.

A single support leg is provided as an integral part of the retractable tow bar mechanism at the front of the machine. Together the four outrigger legs provide a wide footprint to maintain machine stability in wind-speeds up to 118 km/hr.

PRODUCT DESCRIPTION

Transport

In addition, a transport leg is provided on the draw bar near the base of the mast. This leg may be pinned in the lowered position to support the front of the machine for transport or storage in a yard without the need to extend the draw bar.

CAUTION

ENSURE THE TRANSPORT LEG IS RAISED AND PINNED PRIOR TO TOWING THE LIGHTING TOWER.

WARNING

DO NOT CHAIN THE MACHINE DOWN USING THE DRAWBAR IN THE EXTENDED POSITION AND THE FRONT JACK OR JOCKEY-WHEEL DOWN. DAMAGE TO THE DRAWBAR, JACK OR JOCKEY-WHEEL MAY RESULT FROM EXCESSIVE FORCES. ALWAYS USE THE TRANSPORT LEG.

Electrical

Power for the four flood-lights is drawn from a 13 kVA three-phase alternator. The output of the alternator connects directly to a main Residual Current Device (RCD) located in the light's electrical control box. The RCD has a rated trip current of 30 milliamps providing protection to operators against hazards of electrocution. Four separate circuit breakers each rated at 10 amps provide protection to each of the Four light circuits. They also act as the main light circuit isolation switches. An optional single phase 10 amp General Purpose Outlet (GPO) is also provided. This circuit has a separate 10 Amp breaker for protection. On machines without a GPO, a separate RCD test point is fitted.

Engine Control Panel

A compact engine control panel provides a key operated ignition switch with a glow and start position. Warning lamps are also provided on this panel for alternator charge, low engine oil pressure, and glow plugs. Also included is a master ignition toggle switch with emergency quick shut off mechanism. An hour meter and two D.C. push to reset type circuit breakers rated at 20 amps for main D.C. circuit protection and 15 amps for control circuit protection.

Located within the engine control panel enclosure is a timer module which forms part of the glow plug circuit. It provides a preset preheat time for the glow plugs ensuring reliable performance.

Hydraulic System

A 12 V DC motor driving a hydraulic pump provides the fluid-power source for mast assembly movements.

Three lever actuated directional control valves combined with hydraulic-controls enable switch, allow for proportional directional control of mast lift, telescope, and tilt functions.

A main pressure relief valve protects the hydraulic system from over pressure and mast assembly from structural overloading. System relief pressure is set at 2500 psi .

The pump motor draws power from the engine starting battery. This battery is "deep-cycle" and thus allows the mast to be raised and lowered without the main engine running.

PRODUCT DESCRIPTION

Engine Shutdown Timer

An optional Engine shutdown timer may also be fitted. This allows a pre-selectable engine run time of 8, 10, 12 or 14 hours. The timer will commence when the timer switch is turned on and will continue to run for the approximate time selected. At completion of the timed period, the engine will shutdown until the ignition is turned off which resets the system.

Engine Distress Shutdown System

An optional Engine Distress Shutdown System may also be fitted to the Light Tower.

This unit is housed in a small black box (early machines) or a grey box (later machines) within the control panel box. The unit monitors high engine temperature, low engine oil pressure, and low coolant level. It will shutdown the Engine if any of the above conditions occur.

The unit is connected to the oil pressure switch in the engine block; a normally open temperature switch in the head which closes above 115°C; and a coolant sensor probe (early machines) or Float level switch (later machines) located in the radiator overflow bottle.

NOTE: On early machines fitted with sensor probe. As Glycol is highly resistant, the system is sensitive to a high level of Glycol in the water. Do not exceed 50 percent Glycol to 50 percent water as false triggering may occur.

A mark on the overflow bottle indicates minimum fluid level required in the system.

On later machines that are fitted with a float level switch, a new engine shutdown module coloured light grey is fitted. This provides improved performance.

MAINTENANCE PROCEDURES

MAINTENANCE PROCEDURES

Refer to the supplement manual for all service procedures in relation to the Kubota D1403 Diesel Engine.

IMPORTANT

WHEN UNDERTAKING ANY MAINTENANCE OR REPAIR PROCEDURES ON THE LIGHTING TOWER, PARTICULAR ATTENTION SHOULD BE TAKEN ON ALL PROCEDURES INVOLVING WORKING IN, UNDER OR OVER THE MACHINE.

THE FOLLOWING GENERAL GUIDELINES SHOULD BE READ AND UNDERSTOOD PRIOR TO CARRYING OUT ANY MAINTENANCE OR REPAIR WORK.

General

The following information is provided to assist you in the use of maintenance procedures contained in this section.

Safety and workmanship

Your safety, and that of others, is the first consideration when engaging in the maintenance of equipment. Always be conscious of weight. Never attempt to move heavy parts without the aid of a mechanical device. Do not allow heavy objects to rest in an unstable position. When raising a portion of the equipment, ensure that adequate support is provided.

Cleanliness

- (1) The most important single item in preserving the long service life of a machine is to keep dirt and foreign materials out of the vital components. Precautions have been taken to safeguard against this. Shields, covers, seals, and filters are provided to keep air, fuel, and oil supplies clean; however, these items must be maintained on a scheduled basis in order to function properly.
- (2) At any time when air, fuel, or oil lines are disconnected, clean adjacent areas as well as the openings of fittings themselves. As soon as a line or component is disconnected, cap or cover all openings to prevent entry of foreign matter.
- (3) Clean and inspect all parts during servicing or maintenance, and ensure that all passages and openings are unobstructed. Cover all parts to keep them clean. Be sure all parts are clean before they are installed. New parts should remain in their containers until they are ready to be used.

MAINTENANCE PROCEDURES

Components Removal and Installation

- (1) Use adjustable lifting devices, whenever possible, if mechanical assistance is required. All slings (chains, cables, etc.) should be parallel to each other and as near perpendicular as possible to top of part being lifted.
- (2) If a part resists removal, check to see whether all nuts, bolts, cables, brackets, wiring etc., have been removed and that no adjacent parts are interfering.

Hydraulic Lines and Electrical Wiring

Clearly mark or tag hydraulic lines and electrical wiring, as well as their receptacles when disconnecting or removing them from the unit. This will ensure that they are correctly reinstalled. Refer to electrical schematics when re-assembling to ensure correct wiring and connections are achieved.

Hydraulic System

- (1) Keep the system clean. If evidence of metal or rubber particles are found in the hydraulic system, drain and flush the entire system.
- (2) Disassemble and reassemble parts on a clean work surface. Clean all metal parts with a non-flammable cleaning solvent. Lubricate components as required to aid assembly.

Lubrication & Servicing

Components and assemblies requiring lubrication and servicing are listed in the machine's regular maintenance schedule.

Service applicable components with the amount, type and grade of lubricant recommended in this manual, at the specified intervals. When not available, consult your local supplier for an equivalent that meets or exceeds the specifications listed.

Battery

Clean battery, using a non-metallic brush and a solution of baking soda and water. Rinse with clean water. After cleaning, thoroughly dry battery and coat terminals with an anti-corrosion compound.

Engine Distress Coolant Level Probe (Early Machines)

The engine distress coolant level probe located in the radiator overflow bottle may need periodic cleaning to maintain its effectiveness in sensing coolant level. If false triggering occurs, which will cause the engine to shut down or fail to start, then slide the probe out of the bottle and clean the metal surfaces with a very light abrasive such as a scourers and then reinsert the probe into the bottle.

MAINTENANCE PROCEDURES**CHANGING ENGINE OIL**

Refer to supplement manual on Kubota Diesel Engine for procedures relating to engine oil/filter changes.

CHANGING FLOODLIGHT LAMPS**⚠ DANGER**

PRIOR TO ATTEMPTING TO REMOVE OR REPLACE THE LAMPS IN THE LAMP FITTINGS, ENSURE THAT THE ENGINE IS SHUT OFF AND THE GENERATOR IS NOT RUNNING.

⚠ DANGER

DO NOT TOUCH LAMP TERMINALS OR SOCKETS. DANGEROUS VOLTAGES MAY BE PRESENT EVEN WHEN POWER IS OFF. IT IS VERY IMPORTANT TO SWITCH OFF ALL CIRCUIT BREAKERS, EVEN THOUGH THE ENGINE HAS BEEN SHUTDOWN. THIS ISOLATES THE BALLAST CIRCUITS FROM EARTH, PREVENTING A SHOCK HAZARD FROM EITHER LAMP TERMINAL TO EARTH. ALLOW 10 MINUTES FOR BALLAST CAPACITORS TO DISCHARGE BEFORE REPLACING LAMPS. CHECK CAPACITORS ARE BELOW 10VDC BEFORE SERVICE TO LAMP SOCKETS OR BALLAST CIRCUITS BY TRAINED SERVICE PERSONNEL ONLY. SERIES BALLAST CAPACITOR VOLTAGE CAN BE MEASURED ACROSS THE LAMP ASSOCIATED WITH THAT BALLAST USING A 1000 VDC RATED MULTIMETER WITH 1000 VDC RATED SHARP TIP PROBES.

⚠ WARNING

THE LAMPS AND LAMP FITTINGS BECOME VERY HOT AFTER THEY HAVE BEEN RUNNING. PLEASE ALLOW FOR THE LAMP ASSEMBLY TO COOL TO AN ACCEPTABLE TEMPERATURE PRIOR TO ATTEMPTING ANY SERVICE WORK.

Access to the metal halide lamp is through the front glass shield. Open the glass shield by unlatching the clip on either side of the glass and swinging the shield open on its hinges.

IMPORTANT

APPLICABLE EYE PROTECTION AND GLOVES SHOULD BE WORN TO AVOID INJURY FROM BREAKING GLASS.

Disconnect the lamp away from the spring-loaded contacts and remove the lamp from the fitting.

A new lamp is installed in the reverse order with particular attention paid to NOT touching or contaminating the surface of the lamp tube during the installation process.

Ensure the tube is correctly seated on the spring contacts at each end.

Close the glass shield and latch on each side.

Start the engine, switch on the lamp and run the unit for 15 minutes to ensure lamp ignites and runs correctly.

MAINTENANCE PROCEDURES**REMOVING FLOODLIGHT
ASSEMBLY****! DANGER****ENSURE ENGINE IS SHUT DOWN
PRIOR TO REMOVING FLOOD
LIGHTS.**

Prior to removing any of the 4 floodlight assemblies from the light bar, first remove the electrical lead connections at the light bar assembly junction box.

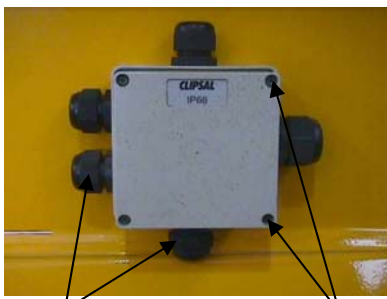

Cable Glands

Remove Screws

Open the lid of the junction box by removing the 4 screws. Locate the relevant B.P. connectors and loosen the wires.

Loosen the plastic cable gland clamp or steel conduit terminator as applicable and withdraw the wire from the gland.

Loosen and remove the nut on the lamp assembly attachment bolt and lower the lamp assembly away from the light bar.

Reinstallation is a reversal of the removal procedure.

NOTE: Ensure that the electrical wires are in good condition and reconnected correctly. Pay particular attention to the connection colours. Refer to the electrical schematic for guidance.

MAINTENANCE PROCEDURES

REMOVING MAST ASSEMBLY

⚠ WARNING

THE MAST ASSEMBLY ON THE LIGHTING TOWER HAS CONSIDERABLE WEIGHT. USE SUITABLE LIFTING DEVICES WHEN LIFTING HEAVY COMPONENTS. THE USE OF A CRANE AND SUITABLE SLING IS HIGHLY RECOMMENDED.

Prior to removal of the mast assembly, the following steps should be taken.



1. Remove the 4 flood lamp assemblies from the light bar as described earlier.
2. Disconnect and cap the hydraulic hoses at the base of the machine.
3. Disconnect the electrical cabling at the ballast compartment.
4. Loosen and remove the one inch UNC nyloc nut at the base of the mast assembly. Access to this nut is through the gap just above the draw bar at the mast pivot weldment. Take note not to lose the thrust washers as the mast is raised up.

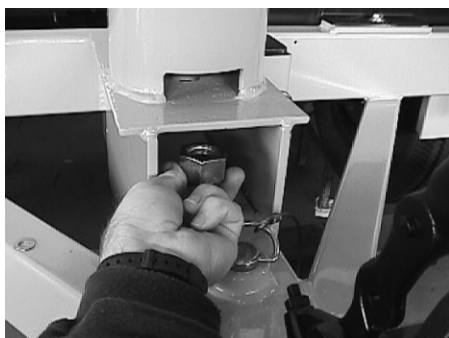

NOTE: It is possible to remove the mast assembly with all light assemblies attached, however, the risk of damage to the front glass of the light is possible.

REPLACEMENT OF AC CIRCUIT BREAKERS

⚠ DANGER

LETHAL VOLTAGES ARE PRESENT WITHIN THE LIGHT CONTROL BOX ENSURE ENGINE/GENERATOR IS SHUTDOWN PRIOR TO CARRYING OUT ANY ELECTRICAL WORK OR REMOVING ANY PROTECTIVE COVERS.

Remove the cover to the light control box which houses the main circuit breaker R.C.D. and light circuit breakers by loosening the 4 cover mounting screws.

On the breaker to be removed, loosen the screw clamp terminals and remove the wires from the terminals.

With the aid of a flat bladed screw driver, dislodge the clip holding the circuit breaker onto the din rail and remove the breaker from the box.

Replacement of the circuit breaker involves clipping the new breaker into place on the din rail and reconnecting the wires.

NOTE: To avoid confusion when reconnecting the wires to a circuit breaker it is advisable that only one circuit breaker at a time be removed and that the wires are suitably labelled prior to removal.

MAINTENANCE PROCEDURES

REMOVE/REPLACEMENT OF LAMP BALLASTS

The flood-light lamp ballasts are located behind the front cover of the lighting tower frame.

! DANGER

BEFORE REMOVING THE FLOOD-LIGHT LAMP BALLASTS, ENSURE THE ENGINE/GENERATOR SET IS SHUT-DOWN AND ISOLATED.

! DANGER

DO NOT TOUCH LAMP TERMINALS, BALLAST TERMINALS OR SOCKETS. DANGEROUS VOLTAGE MAY BE PRESENT EVEN WHEN POWER IS OFF. IT IS VERY IMPORTANT TO SWITCH OFF ALL CIRCUIT BREAKERS, AFTER ENGINE SHUT-DOWN. THIS ISOLATES THE BALLAST CIRCUITS FROM EARTH, PREVENTING A SHOCK HAZARD FROM EITHER LAMP TERMINAL TO EARTH. ALLOW 10 MINUTES FOR BALLAST CAPACITORS TO DISCHARGE BEFORE REPLACING LAMPS. ONLY TRAINED SERVICE PERSONNEL SHOULD CHECK THAT CAPACITORS ARE BELOW 10 VDC BEFORE SERVICING LAMP SOCKETS OR BALLAST CIRCUITS BY TRAINED SERVICE PERSONNEL ONLY. SERIES BALLAST CAPACITOR VOLTAGE CAN BE MEASURED ACROSS THE LAMP ASSOCIATED WITH THAT BALLAST USING A 1000 V D.C. RATED MULTIMETER WITH 1000 V D.C. RATED SHARP TIP PROBES.

! WARNING

THE LAMPS AND LAMP FITTINGS BECOME VERY HOT AFTER THEY HAVE BEEN RUNNING. PLEASE ALLOW FOR THE LAMP ASSEMBLY TO COOL TO AN ACCEPTABLE TEMPERATURE PRIOR TO ATTEMPTING ANY SERVICE WORK. ACCESS TO EITHER METAL HALIDE OR HPS LAMP TYPES IS THROUGH THE FRONT GLASS SHIELD BY UNLATCHING THE CLIP ON EITHER SIDE OF THE GLASS AND SWINGING THE SHIELD OPEN ON ITS HINGES.

- First remove the cover by removing the TEK screws holding the cover in place. This will expose the Ballast assemblies.

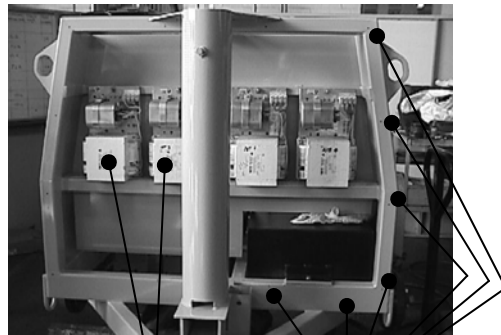

Ballast
Assembly x 4

TEK
Screws

- Take a note of the wire connections to the ballast to be removed and loosen the screw terminals and remove the wires.
- Loosen and remove the 5/16" nyloc nut holding the top of the ballast in place. Remove the washer and tilt the top of the ballast forward.

FAULT DIAGNOSIS CHART
Lights and Generator Circuit

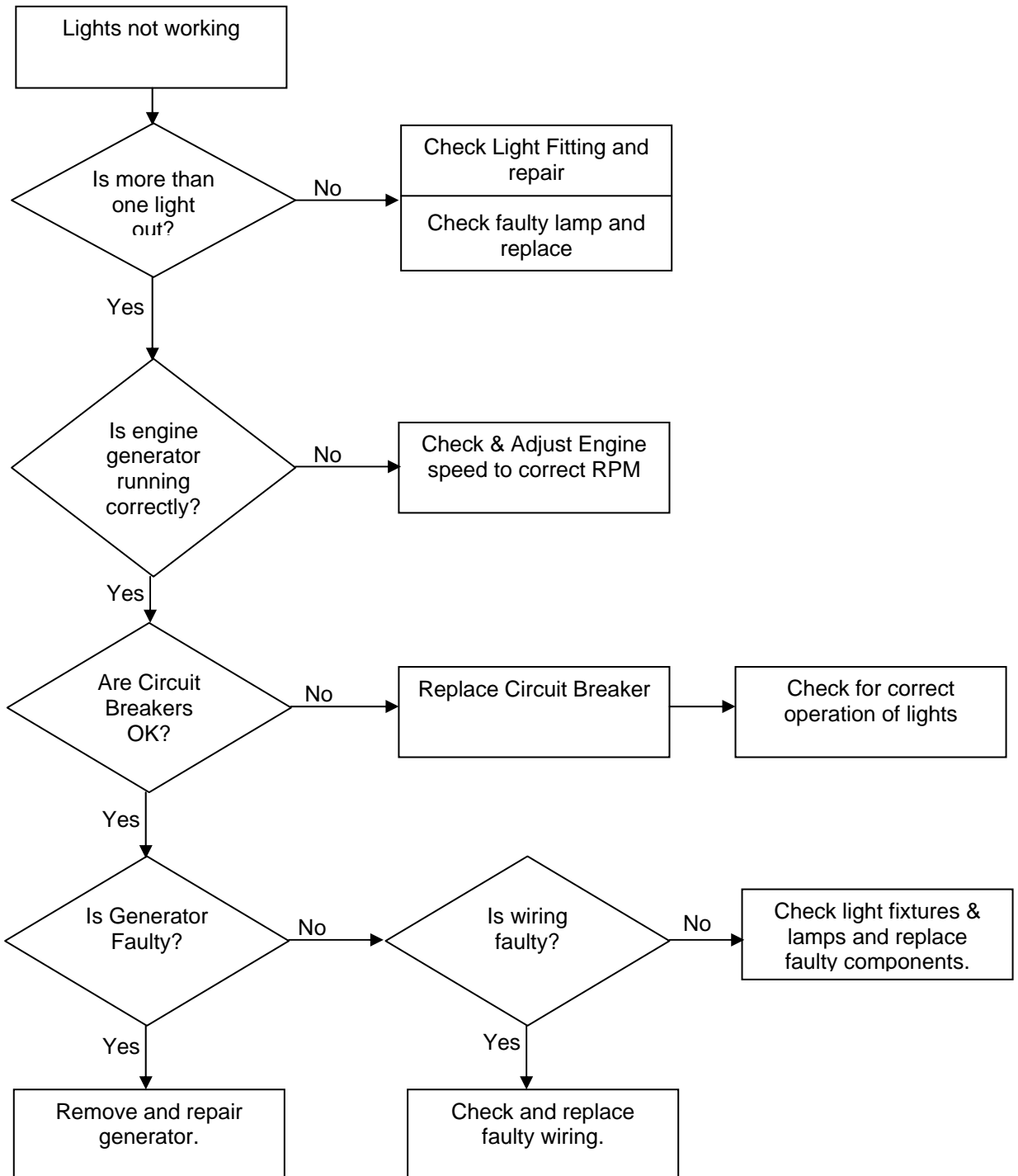

FAULT DIAGNOSIS CHART
Engine

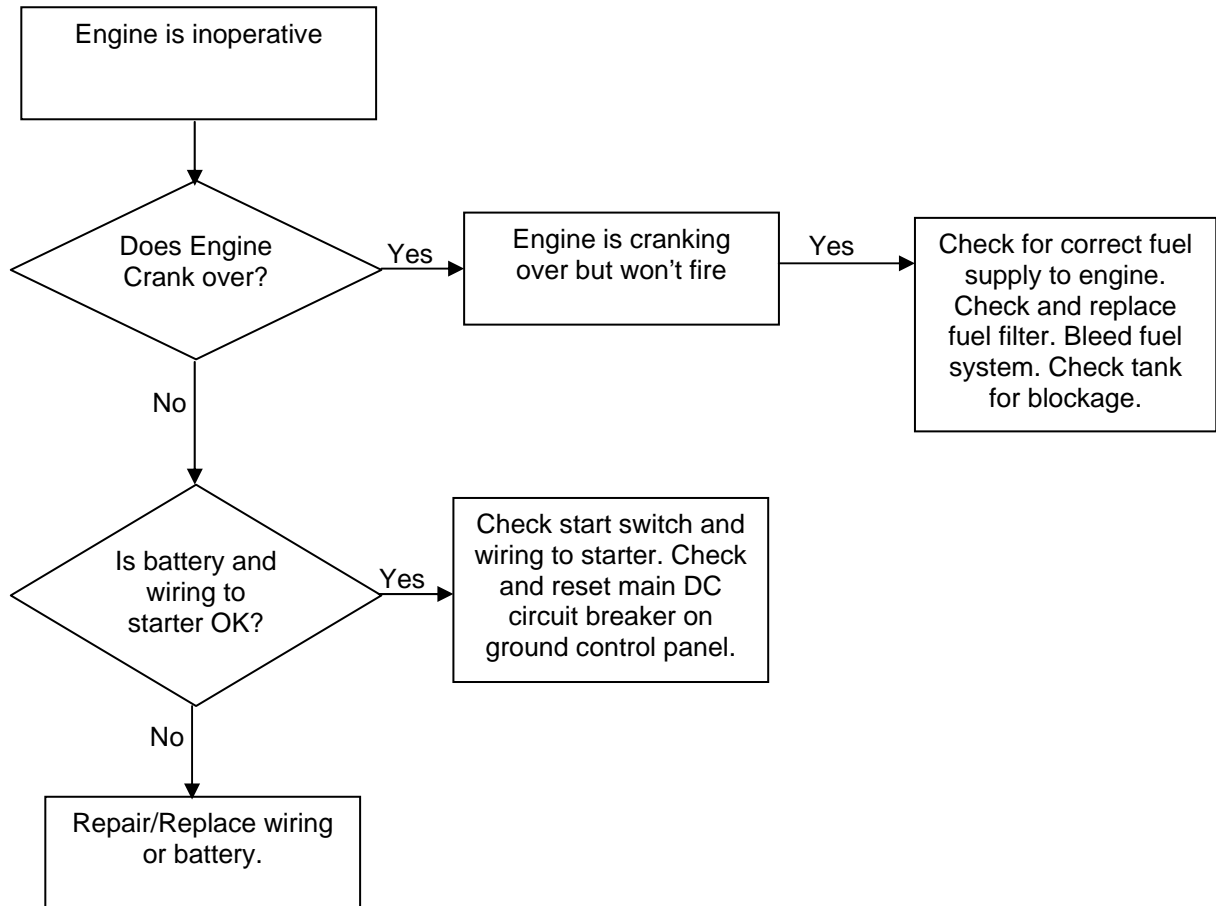

ELECTRICAL SAFETY TESTS

AS3760 tests

The machine needs to have a GPO (or a dedicated RCD test connector) wired to the load side of the 3-phase MCB/RCD to perform the tests required by AS3760 (earthing continuity, insulation, and RCD tests).

Machines fitted with a GPO prior to serial # 6308AN222 had the 240 V feed for the GPO taken from the alternator side of the MCB/RCD with its own RCD. These machines can easily be modified for AS3760 testing by qualified electrical personnel by wiring the 240 V GPO feed on the load side of the MCB/RCD, and replacing the single phase GPO RCD with a 10 A one-pole circuit breaker and one-module width blank plate.

DANGER!

DO NOT TOUCH LAMP TERMINALS OR SOCKETS.

Dangerous voltages may be present even when power is off. Shutdown engine, **SWITCH OFF ALL CIRCUIT BREAKERS**, and allow 10 minutes for ballast capacitors to discharge before replacing lamps. Check capacitors are below 10 V DC before service to lamp sockets or ballast circuits by trained service personnel only.

Ballast safety tests

Ballast safety tests should be carried out by trained personnel, using suitable test equipment, at 6 monthly intervals. Before testing, turn off all circuit breakers, shutdown engine, and allow lamps to cool. Wait at least 10 minutes after switch off to allow capacitor discharge before testing ballast circuits –

1. Ballast circuits insulation test – Switch the 3-phase RCD/MCB on and the GPO switch on. To test the GPO neutral is connected correctly, check the resistance between earth and neutral at the GPO (with a multimeter) is less than 1 ohm (Ω). Switch the 3 phase MCB/RCD off, and with the GPO switch still on, measure insulation resistance at 500 V DC between neutral and earth at the GPO (or dedicated test connector). This should be greater than 1 M Ω (typically >100 M Ω). If the GPO is not wired on the load side of the 3-phase MCB/RCD, neutral is best accessed by removing the front panel of the electrical switchboard.
2. Ballast capacitor discharge resistor test –
 - a) Residual voltage across ballast capacitors - Open the glass cover on one of the lamp housings. Using a digital multimeter with 1000 V DC rated sharp tip test probes, measure the voltage across the lamp globe on the 200 V DC range. The reading should be less than 0.5 V DC (typically zero). If the voltage measured is greater than this, one or both of the capacitor discharge resistors on the associated ballast is faulty and that capacitor should be replaced. Remove the ballast compartment cover, and on the associated ballast, discharge each capacitor individually using a 1000 V rated test lead with sharp tipped probes. Confirm with a voltmeter that the voltage across each capacitor is below 0.5vdc before proceeding to step b.
 - b) Discharge resistor resistance measurement – If the voltage across the lamp measured in step a) was below 0.5 V DC, measure the resistance across the lamp with a multimeter set to the 2Mohm range. Each capacitor has a 470 k Ω discharge resistor, so the series resistance measured across the lamp should be 940 k Ω \pm 10% - ie between 846 k Ω (0.846 M Ω) and 1,034 k Ω (1.034 M Ω). Allow a minute or two for the resistance reading to stabilize as the meter current charges the capacitors. Replace any capacitors with faulty discharge resistors.
 - c) Repeat the test for each lamp circuit.

ELECTRICAL SAFETY TESTS

Alternator voltage tests

AC voltage tests should be done every 1000 hours or 12 months by trained personnel with suitable test equipment. Voltage tests should not be done with any faulty lamp circuits switched on. Abnormal loading by a faulty ballast or lamp can cause variations in engine speed and voltage. Before starting the tests, remove the front panel from the switchboard. Check the bottom engine pulley and make sure it has a timing mark suitable for optical tachometer registration. Check that the tacho is functioning correctly by starting the engine and measuring RPM. Double check the tachometer accuracy with a frequency meter plugged into the GPO before any adjustments are made during the test procedures below. Multiply the A.C. frequency x 30 to calculate engine RPM. 50 Hz AC corresponds to 1500 rpm.

1. Switch all lamps on. Allow the engine and lamps to reach operating temperature (1/4 hr).
2. Loaded engine speed - Engine revs under full load should be between 1500 and 1550 rpm.
3. Loaded voltage – Using a digital multimeter with 1000 V AC rated probes on the 600 V AC or 1000 V AC range, measure between active and neutral for each phase on the MCB/RCD. The loaded voltage on each phase should be between 230 V AC and 250 V AC.
4. Unloaded engine speed – Switch all 4 lamp circuit breakers off, but leave the engine running. Engine speed should be between 1530 and 1600 rpm.
5. Unloaded voltage measurement – With the engine still running from step 3, the unloaded voltage should be between 230 V AC and 250 V AC. The alternator does not reach its true unloaded voltage after each start up until it has first been run under load.
 - a) If both engine speeds are high, and both voltages are high, adjust the engine speed down to the correct setting ie 1550 rpm unloaded. Go back to step 5 and recheck that the unloaded voltage is within the acceptable range. If it isn't, go to step 5 d). If it is, allow time for the lamps to cool (20 minutes after switch off) and go back to step 1 to repeat the voltage test.
 - b) If the engine speeds are low, and the voltages are low, adjust the engine speed up to the correct setting i.e. 1550 rpm unloaded. Go back to step 5 and recheck that the unloaded voltage is within the acceptable range. If it isn't, go to step 5 d). If it is, allow time for the lamps to cool (20 minutes after switch off) and go back to step 1 to repeat the voltage test.
 - c) If the loaded and unloaded engine revs are more than 50 rpm different, there is abnormal loading (AC current to each ballast should be approximately x 6.9 A), or the governor on the diesel engine is not functioning correctly.
 - d) If the engine speeds are good, but both voltages are too high or too low, the open circuit voltage on the alternator needs to be reset. Consult the alternator manual and Meccalte in SA or JLG Industries (Australia) in Port Macquarie NSW for the correct procedure. Do not operate the lamps until the open circuit voltage is correctly set. Use a 2400 W test load plugged into the GPO to load the alternator for a few seconds before measuring the unloaded voltage out of the alternator during the adjustment procedure. Repeat the voltage tests after the alternator adjustment.
 - e) If the engine speeds are good, but the difference between unloaded and loaded voltages is too great, the alternator load compensation setting and the open circuit voltage setting may need to be adjusted. Consult the alternator manual and Meccalte in SA or JLG Industries (Australia) in Port Macquarie NSW for the correct procedure. Do not operate the lamps until the open circuit voltage is correctly set. Use a 2400 W test load plugged into the GPO to load the alternator for a few seconds before measuring the unloaded voltage out of the alternator during the adjustment procedure. Repeat the voltage tests after the alternator adjustments.

REGULAR MAINTENANCE SCHEDULE

Item	Daily	50hrs	100hrs	200hrs	400hrs	500hrs	Yearly	1500hrs	3000hrs
Check Engine Oil Level	•								
Check Radiator Coolant Level	•								
Check Machine for damage/leaks	•								
Check Decals Legible	•								
Check all controls function as per manual	•								
Check RCD operation			•						
Change Engine oil		*		•					
Check tyre pressure		•							
Clean Air Cleaner element			•						
Check battery water level			•						
Check fan belt tightness			•						
Check radiator hoses clamps				•					
Replace oil filter cartridge					•				
Replace fuel filter cartridge					•				
Drain clean fuel tank. Clean & flush radiator cooling system. Replace fan belt						• • •			
Replace Air cleaner element. Check valve clearance. Check fuel injection for correct operation. Check fuel injection pump. Bleed brake hydraulic system.							• •	• • •	
Mast rotate mechanism lift/tilt cylinder bushes grease.					•				
Outrigger legs locking pins – check free operation, lubricate with WD40 or equivalent.				•					
Check mast pins bushings for wear.						•			
Check fuel injection timer									•
Check tow hitch and safety chains for secure operation				•					
Check chassis frame for cracks and damage.						•			
Check alternator, bearings, mounts.							•		
Check tyres for wear, splits, damage.				•					
Visual check of all electrical wires and connections for damage.				•					
AS3760 Electrical safety Tests	SEE AS3760								
Ballast Safety Tests	6-monthly								
Voltage Tests							•		

* 1st oil change after 50hrs, subsequent oil changes at every 200hrs.

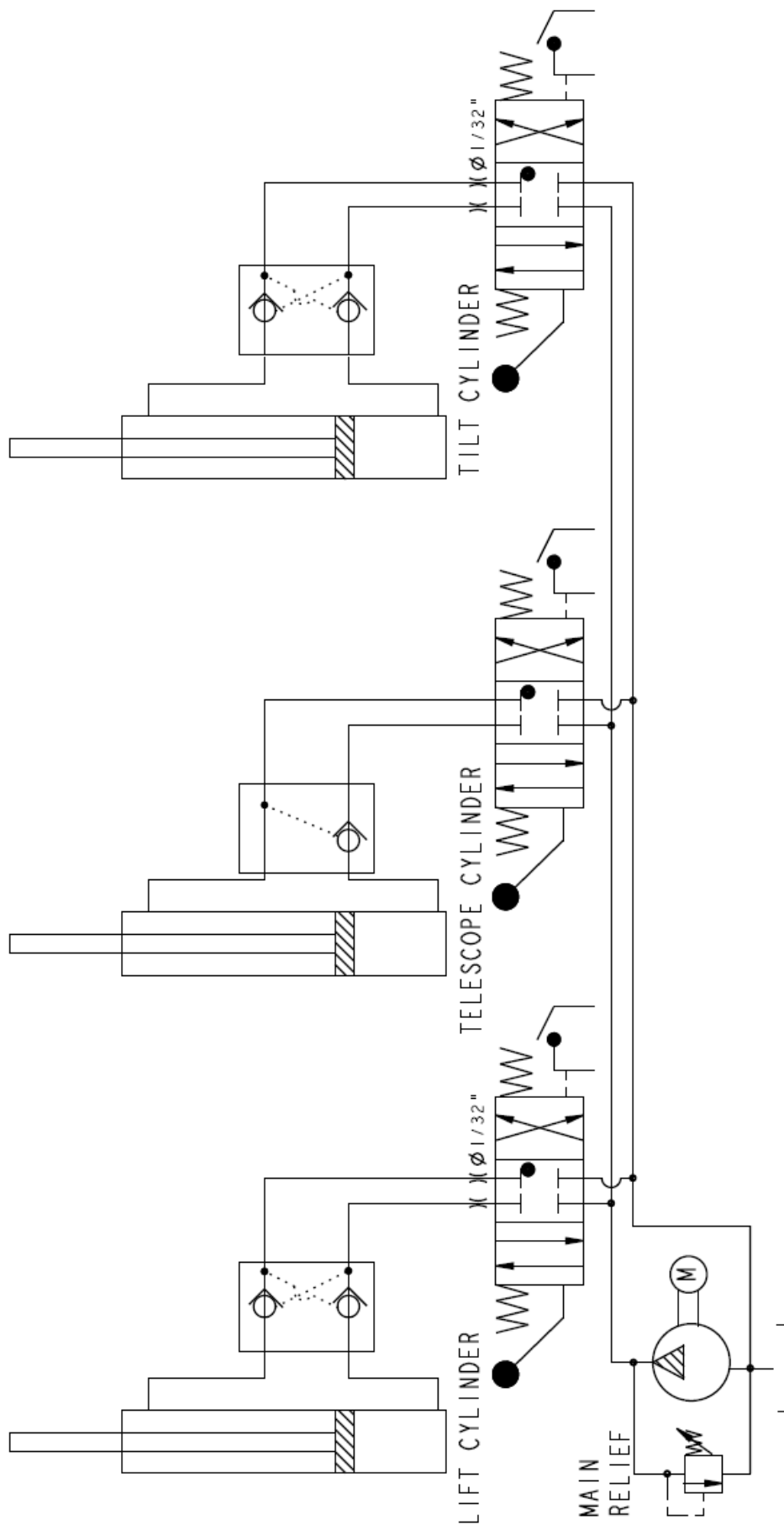
HYDRAULIC SCHEMATIC

ELECTRICAL SCHEMATIC - AC

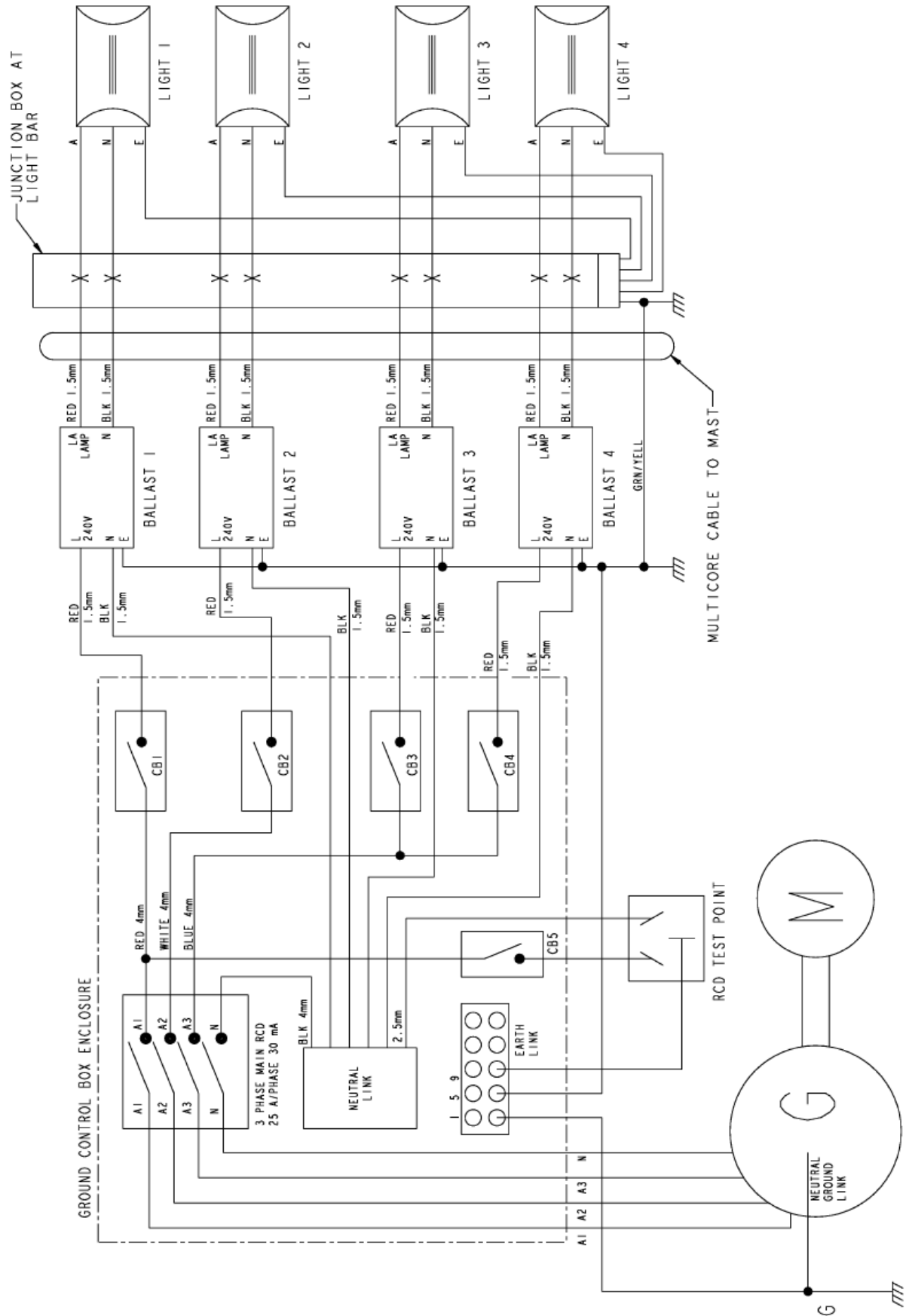

ELECTRICAL SCHEMATIC - DC

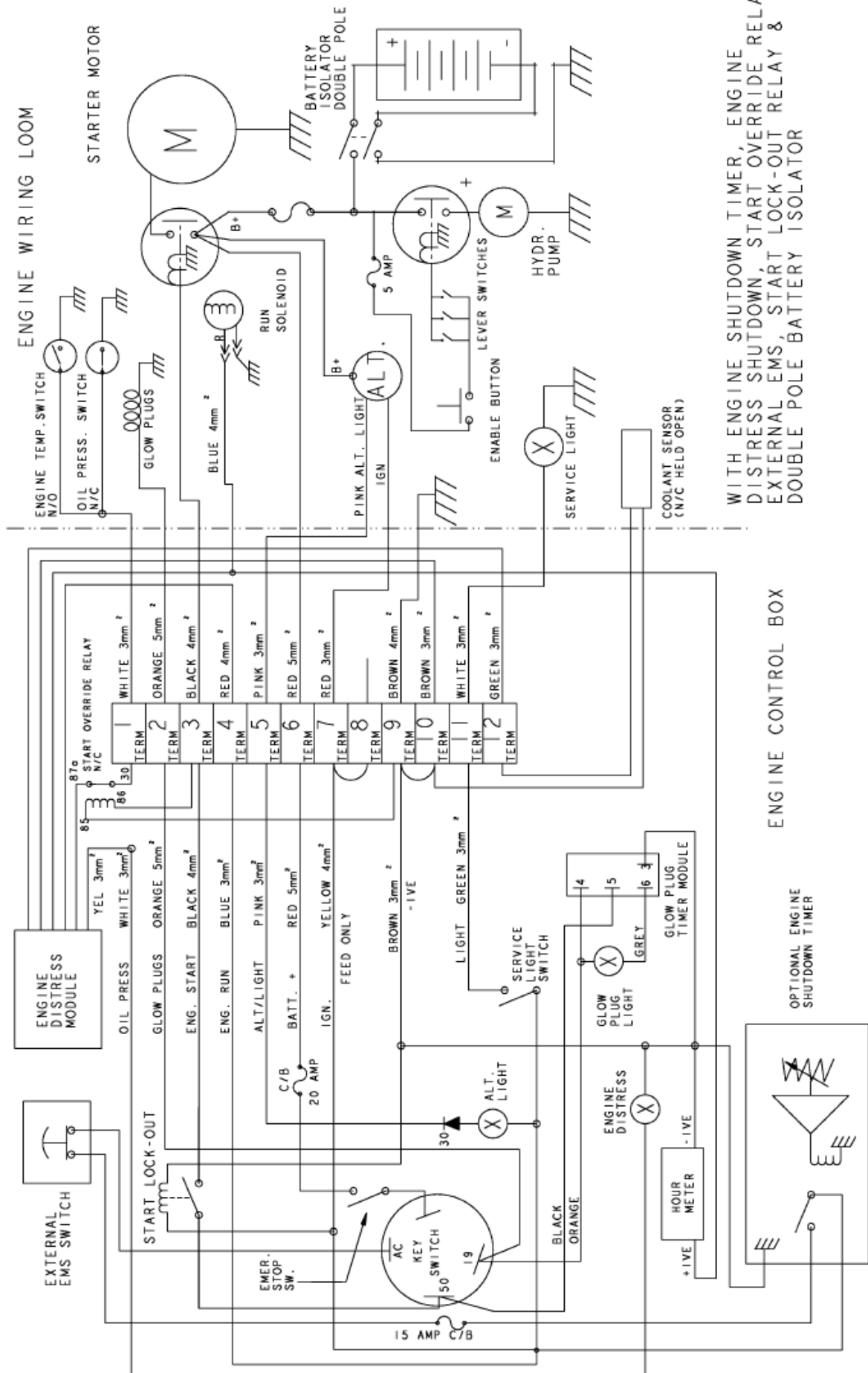

WITH ENGINE SHUTDOWN TIMER, ENGINE DISTRESS SHUTDOWN, START OVERRIDE RELAY, EXTERNAL EMS, START LOCK-OUT RELAY & DOUBLE POLE BATTERY ISOLATOR

SECTION THREE

ILLUSTRATED PARTS MANUAL

CONTENTS:

- MACHINE LEFT SIDE VIEW 3-1
- MACHINE RIGHT SIDE VIEW 3-2
- MACHINE FRONT VIEW 3-3
- MACHINE REAR VIEW 3-6
- HYDRAULIC CONTROLS AND PUMP 3-7
- LIGHTS CONTROL BOX 3-9
- ENGINE CONTROL BOX 3-11
- KUBOTA ENGINE – LEFT SIDE 3-13
- KUBOTA ENGINE – RIGHT SIDE 3-16
- PERKINS ENGINE – LEFT SIDE 3-17
- PERKINS ENGINE – RIGHT SIDE 3-20
- ALTERNATOR, BATTERY & BATTERY ISOLATOR SWITCH 3-21
- MAST ASSEMBLY 3-23
- CYLINDERS 3-25
- LIGHT BAR ASSEMBLY 3-28
- FLOODLIGHT ASSEMBLY 3-29
- OTHER CHASSIS COMPONENTS 3-31
- RADIATOR OVERFLOW BOTTLE 3-33

MACHINE LEFT SIDE VIEW

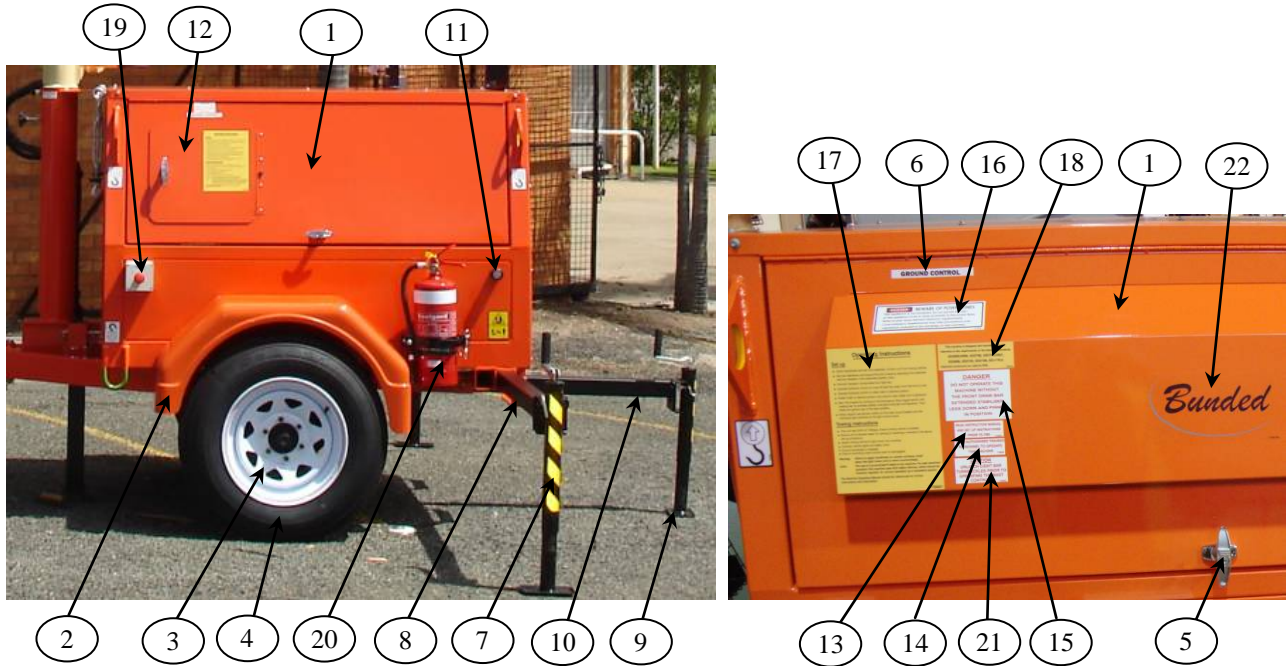

Item	Part Number	Qty	Description of Part
1	1730705	1	Door LH Side Assembly (Series I only)
	1733280	1	Door with Vent Assembly LH
2	1730829	1	Guard LH Side Fibreglass (Prior to S/N 6308AN1840)
	1734233	1	Mudguard Shield Finished LH (S/N 6308AN1840 to Present)
3	1730603	1	16" x 6J Wheel Rim
4	1730618	1	205/80 x 16" Tyre
5	1730529	2	Handle Lock Door (3 for Series I Machines)
	1730790	2	Handle Locking Tab (3 for Series I Machines)
	1730916	2	Coates Door Lock (Coates Spec) (3 for Series I Machines)
	1730033	2	Padlock Handle & S Bracket (Coates Spec)
6	1700037	1	Decal 'Ground Control'
7	A330010	2	Outrigger Side Jack Assembly
8	1730533	2	Outrigger Side Extension Arm
9	1730777	1	Outrigger Rear Jack Assembly (Series I only)
10	1730749	1	Outrigger Rear Extension Arm (Series I only)
11	1730750	2	Block Stop Stabilizer Storage
12	1730820	1	Access Door (Series I only)
13	1730596	1	Decal 'Only Authorised Trained Personnel'
14	1730597	1	Decal 'Read Instruction Manual'
15	1730598	1	Decal 'Do Not Operate Unless Outrigger Legs Down'
16	1736529	1	Decal 'Danger Beware of Power Lines'
17	1730831	1	Decal 'Operating Instruction'
18	1730734	1	Decal 'Standards compliance'
19	4360475	1	Emergency Stop Switch
	1733231	1	Single Gang Junction Box Base (GWR)
	1733047	1	Single Gang Junction Box Cover (GWR)
	1730574	1	Single Gang Enclosure (Clipsal)
20	1730853	1	Fire Extinguisher 9kg (Option)
	1734123	1	Fire Extinguisher 4.5kg
	1733802	1	Fire Extinguisher 1kg
21	1730535	1	Decal 'Unlatch Light Bar'
22	1734174	2	Decal 'Bunded' (Series II)

MACHINE RIGHT SIDE VIEW



Item	Part Number	Qty	Description of Part
1	1730611	1	Door RH Side Assembly (Series I only)
	1733764	1	Door with Vent Assembly RH
2	1730830	1	Guard RH Side Fibreglass (Prior to S/N 6308AN1840)
	1734232	1	Mudguard Shield Finished LH (S/N 6308AN1840 to Present)
3	1701500	6	Decal Tie Down/Lift
4	1701785	2	Crushing Hazard
5	1734185	1	Decal 'Engine Oil and Bunding Drain' (Series II)
6	1734046	1	Tap, BSP 1/4" (Series II)
7	1733735	2	Urethane Wheel Chock (Option)
8	1733736	2	Wheel Chock Mount Bracket (Option)

MACHINE FRONT VIEW

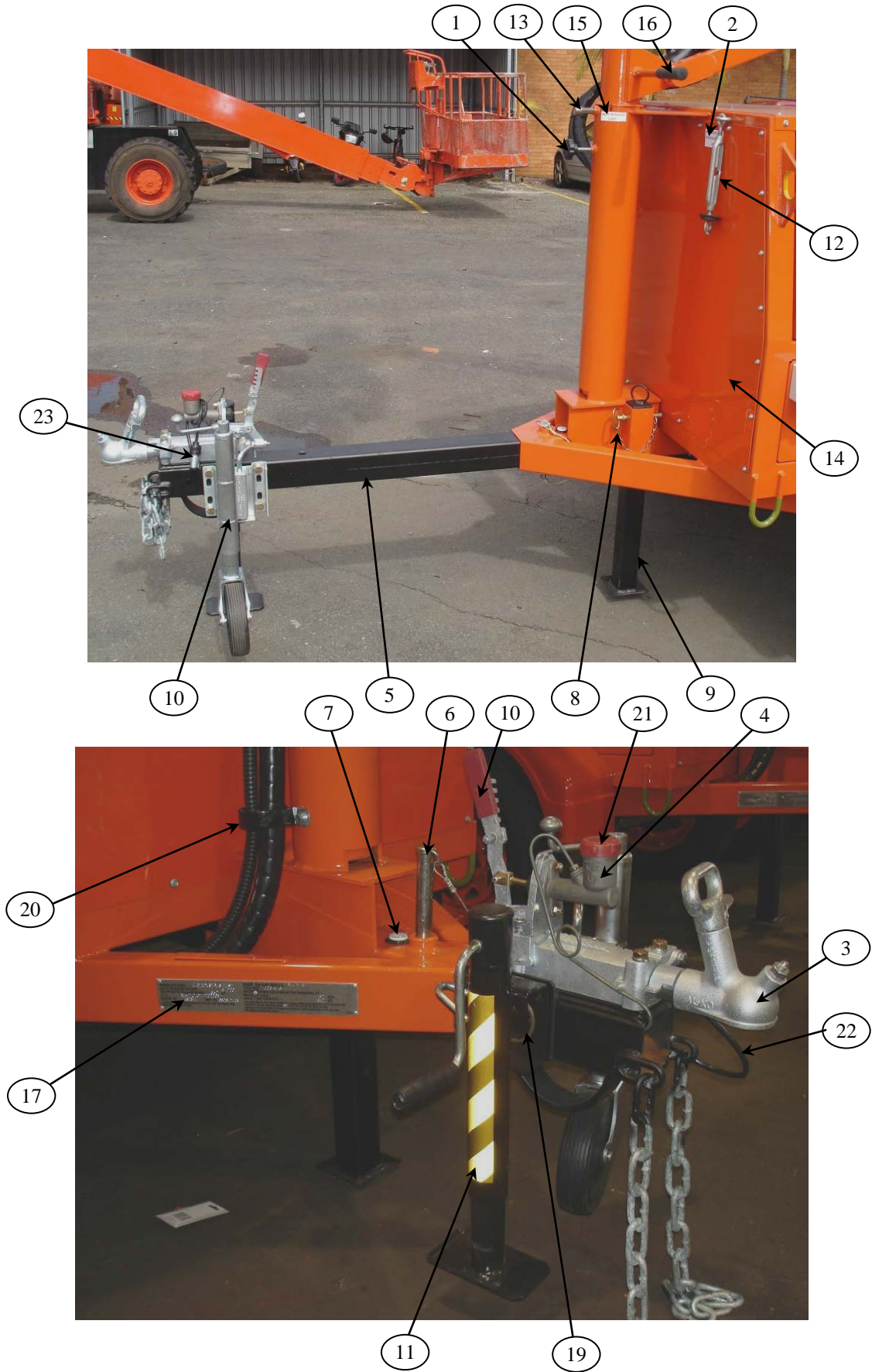

Item	Part Number	Qty	Description of Part
1	A620550	1	Mast Rotate Locking Knob (Prior to S/N 6308AN1464)
	1734165	1	Mast Rotate Locking Knob (S/N 6308AN1464 to Present)
2	1730599	1	Decal – Maximum Voltage Within Enclosure
3	1735456	1	Tow Coupling – Override Tow Ball Type
4	1737060	1	Cylinder Hydraulic Brake
5	1730901	1	Weldment Front Drawbar Extension
6	1733267	1	Drawbar Pin Assembly
7	1733106	1	Bubble Level
8	1733192	1	Transport Leg Hitch Pin
	1733193	1	Transport Leg Pin Chain
9	1730580	1	Transport Leg Weldment
10	1730952	1	Jockey Wheel
11	A650235	1	Front Outrigger Jack
12	1730759	2	Eye Bolt
	1730760	2	Turn Buckle
	1730773	2	Rubber Bumper Turnbuckle
13	3422744	1	Pin Plunger
14	1730607	1	Front Panel
15	1730747	1	Decal Mast Rotation Lock
16	1730797	1	Mast Rotate Handle Grip
17	1737103	1	Decal ‘Vin Plate Identification’
18	1730578	1	Brake Handle Park Brake
19	A330014	4	Outrigger Circlip
20	1320219	3	Hose Clamp 2½” Steel P Clip
21	1734707	1	Cap Hyd Brake Reservoir
22	1730520	6m	5 Core Trailer Cable
23	1737066	1	7 Pin Small Round Metal Trailer Plug
	1730881	1	7 Pin Large Round Metal Trailer Plug (Coates Vic Spec)
	1730863	1	7 Pin Flat ‘Quickfit’ Trailer Plug (Coates NSW Spec)
	1730894	1	7 Pin Large Round Metal Trailer Socket (Coates Qld Spec)

This page left blank intentionally

6308AN

MACHINE REAR VIEW



6308AN Series I

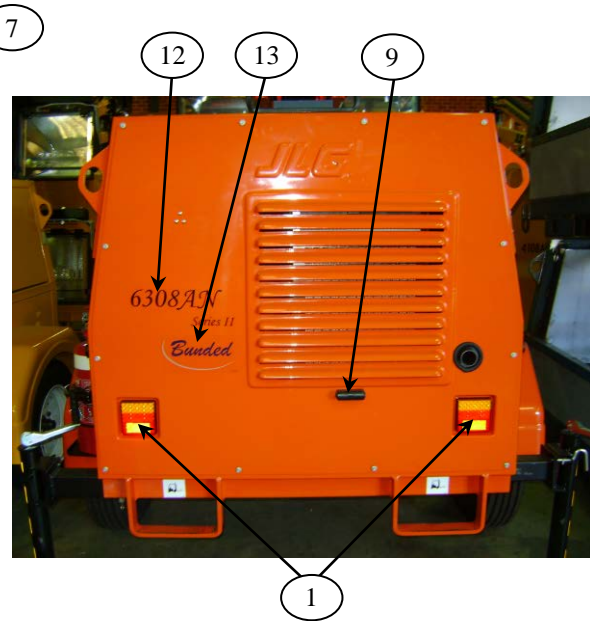

6308AN Series II

Item	Part Number	Qty	Description of Part
1	1733618	2	Tail Light Assembly
	1733980	1	Lamp Bulb 12V 21/5W (Brake)
	1730951	1	Lamp Bulb 12V 21W (Blinker)
	1734145	2	Tail Light Assembly L.E.D.
2	1730819	1	Decal Rear Outrigger (Prior S/N 6308AN268) (Not Shown)
3	1703073	2	Decal 'Forklift Pocket'
4	1730534	1	Mast Support Cradle
5	1730617	1	Decal '6308AN' (Series I only)
6	1732597	1	Wear Pad, Main Boom
7	1001144507	1	Rear Panel
	1001144809	1	Rear Panel (Series II Kubota D1403 Engine)
	1001144810	1	Rear Panel (Series II Perkins 403D-11 Engine)
8	1730606	1	Roof Panel (Series I Kubota D1403 Engine)
	1730949	1	Roof Panel (Series I Kubota D1703 Engine)
	1734541	1	Roof Panel (Series I Perkins 403D-11 Engine)
	1734092	1	Roof Panel (Series II)
9	1730914	1	Licence Plate Lamp (S/N 6308AN269 to Present)
	1730593	1	Number Plate Light Narva (Prior S/N 6308AN268)
10	3422369	2	Outrigger Extension Arm Lock Pin
11	1730735	1	Muffler Guard (Series I)
12	1734186	1	Decal '6308AN Series II' (Series II)
13	1734174	2	Decal 'Bunded' (Series II)

MAST HYDRAULIC CONTROLS AND PUMP

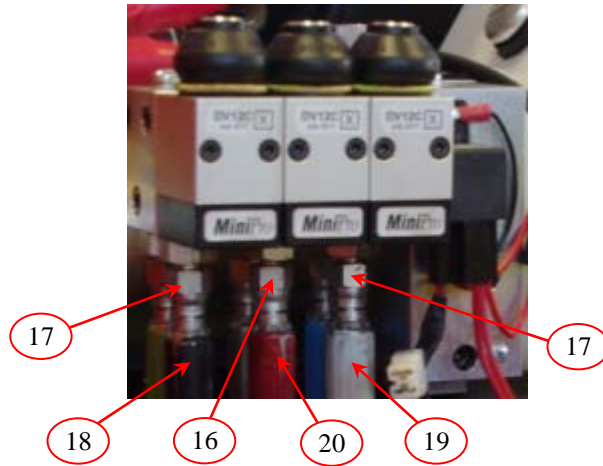
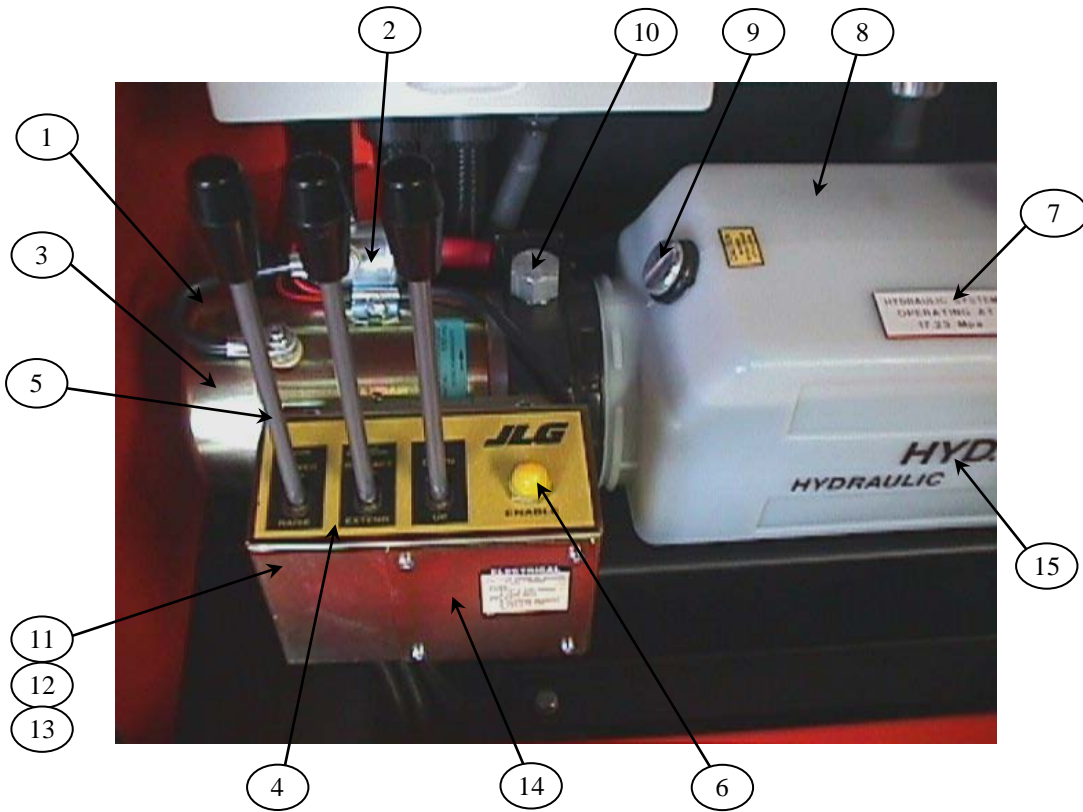

Item	Part Number	Qty	Description Of Part
1	1730543	1	Power Pack Assembly Complete Fenner
2	1730549	1	Solenoid Motor Run 12V
3	1730583	1	Electric Motor
4	1730726	1	Decal 'Lift, Tele, Tilt'
5	1730548	3	Control Lever with Knob
6	4360387	1	Switch Pushbutton. Hydraulic Enable
7	1730547	1	Decal 'Hydraulic System Operating at 17.23MPa'
8	1730854	1	Oil Reservoir
9	1730855	1	Filler/Breather Cap
10	1730856	1	Relief Valve Kit (with Relief Valve, Load Check and Plug)
11	1730857	3	Complete Actuator Assembly (with Handle Actuator Block, Boot, Spring Mechanism, Switch and Spool)

12	1730858	3	Boot Kit (with Boot, Boot Gland and Boot Spring)
13	1730859	3	Handle Actuator Switch Kit (with Switch, Mounting Plate and Screws)
14	1730860	1	Metal Valve Cover
15	1700419	1	Decal 'Hydraulic Oil'
16	1734248	2	Nipple M/M with Encapsulated Seal ¼ x 7/16
17	1734249	4	Nipple M/M with Encapsulated Seal and Orifice ¼ x 7/16
18	1733346	2	Lift Cylinder Hose Assembly
19	1733347	2	Tilt Cylinder Hose Assembly
20	1733348	2	Tele Cylinder Hose Assembly

MAST HYDRAULIC CONTROLS AND PUMP

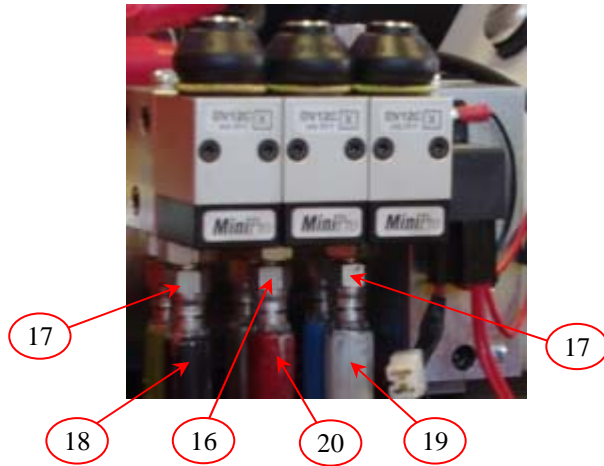
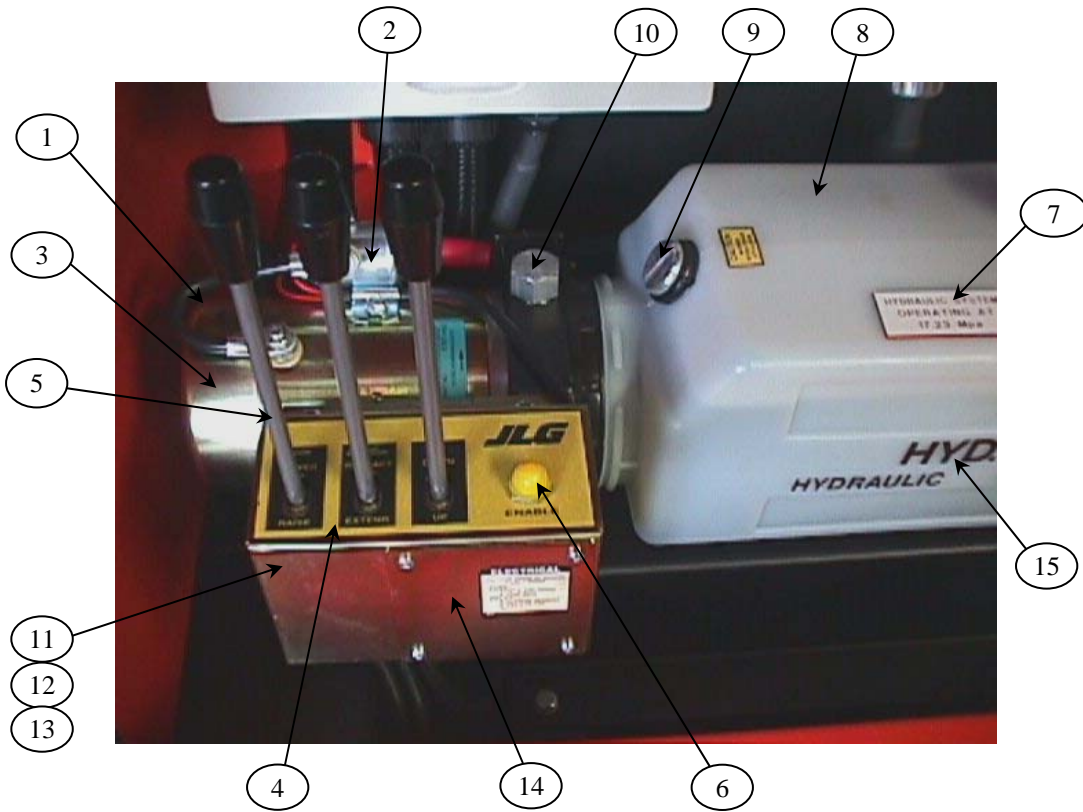

Item	Part Number	Qty	Description Of Part
1	1730543	1	Power Pack Assembly Complete Fenner
2	1730549	1	Solenoid Motor Run 12V
3	1730583	1	Electric Motor
4	1730726	1	Decal 'Lift, Tele, Tilt'
5	1730548	3	Control Lever with Knob
6	4360387	1	Switch Pushbutton. Hydraulic Enable
7	1730547	1	Decal 'Hydraulic System Operating at 17.23MPa'
8	1730854	1	Oil Reservoir
9	1730855	1	Filler/Breather Cap
10	1730856	1	Relief Valve Kit (with Relief Valve, Load Check and Plug)
11	1730857	3	Complete Actuator Assembly (with Handle Actuator Block, Boot, Spring Mechanism, Switch and Spool)

12	1730858	3	Boot Kit (with Boot, Boot Gland and Boot Spring)
13	1730859	3	Handle Actuator Switch Kit (with Switch, Mounting Plate and Screws)
14	1730860	1	Metal Valve Cover
15	1700419	1	Decal 'Hydraulic Oil'
16	1734248	2	Nipple M/M with Encapsulated Seal ¼ x 7/16
17	1734249	4	Nipple M/M with Encapsulated Seal and Orifice ¼ x 7/16
18	1733346	2	Lift Cylinder Hose Assembly
19	1733347	2	Tilt Cylinder Hose Assembly
20	1733348	2	Tele Cylinder Hose Assembly

LIGHT CONTROL BOX

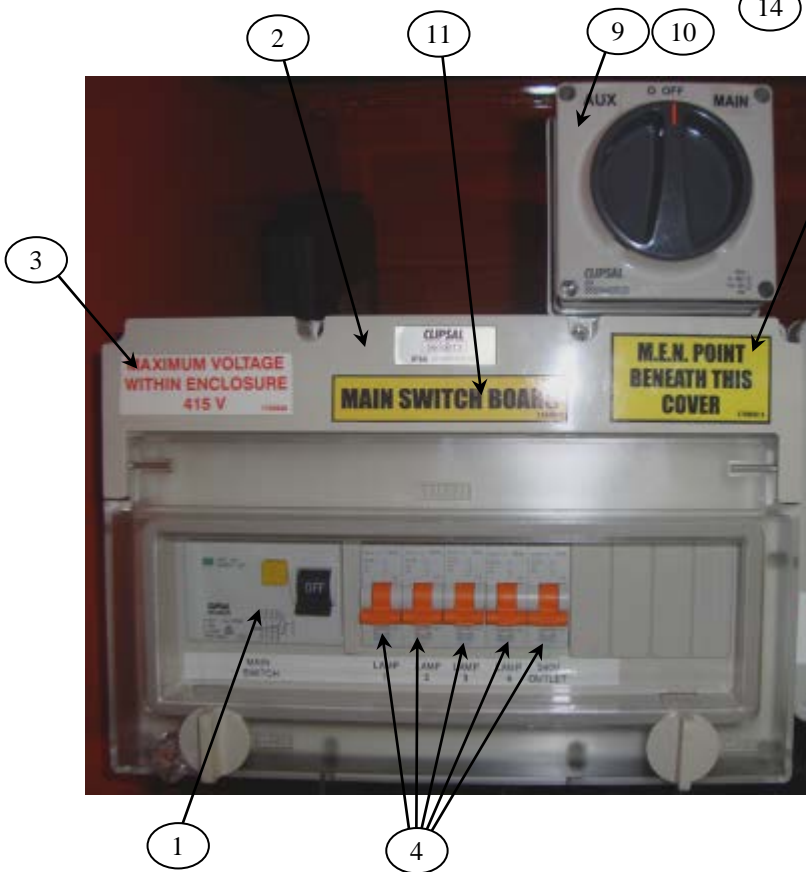

Item	Part Number	Qty	Description of Part
1	1730621	1	Main RCD Clipsal 4RC425/30
2	1730624	1	Clipsal Enclosure 56SB13
3	1730536	1	Decal 'Maximum voltage 415V'
4	1730622	5	Single Pole Circuit Breaker
	1730197	5	Double Pole Circuit Breaker (Clipsal)
	1733227	5	Double Pole Circuit Breaker (Pulset)
5	1730836	1	Auto Switched Outlet (Clipsal)
	1733228	1	Auto Switched Outlet (GWR)

6	1733231	1	Single Gang Enclosure Base
7	1750106	1	Neon Cover (Clipsal)
	1733230	1	Neon Cover (GWR)
8	1750104	1	3 Gang Enclosure Base (Clipsal)
	1733229	1	3 Gang Enclosure Base (GWR)
9	1730998	1	Triple Pole Switch (Option)
10	1735107	1	Single Gang Enclosure Base (Clipsal) (Option)
11	1734017	1	Decal 'Main Switch Board'
12	1730832	1	Decal 'M.E.N Point Beneath this Cover'
13	1730925	1	Decal 'RCD Test Point Only'
14	1730623	1	RCD Circuit Breaker G.P.O. Wilco RCBM210/30 (Option)
15	1733216	3	M20 to M16 Nylon Gland
Other 240V Components Not Shown			
	1735066	1	25-20 Reducer
	1733215	3m	25mm Nylon Conduit
	1733214	1m	16mm Nylon Conduit
	1733217	2	M25 to M25 Nylon Gland
	1320224	1	Cable Clamp
	1737284	1	GPO Clipsal 56C310D (Option)
	1730862	6	Earth Tag for Steel Conduit Swivel Fitting (Option)

ENGINE CONTROL BOX

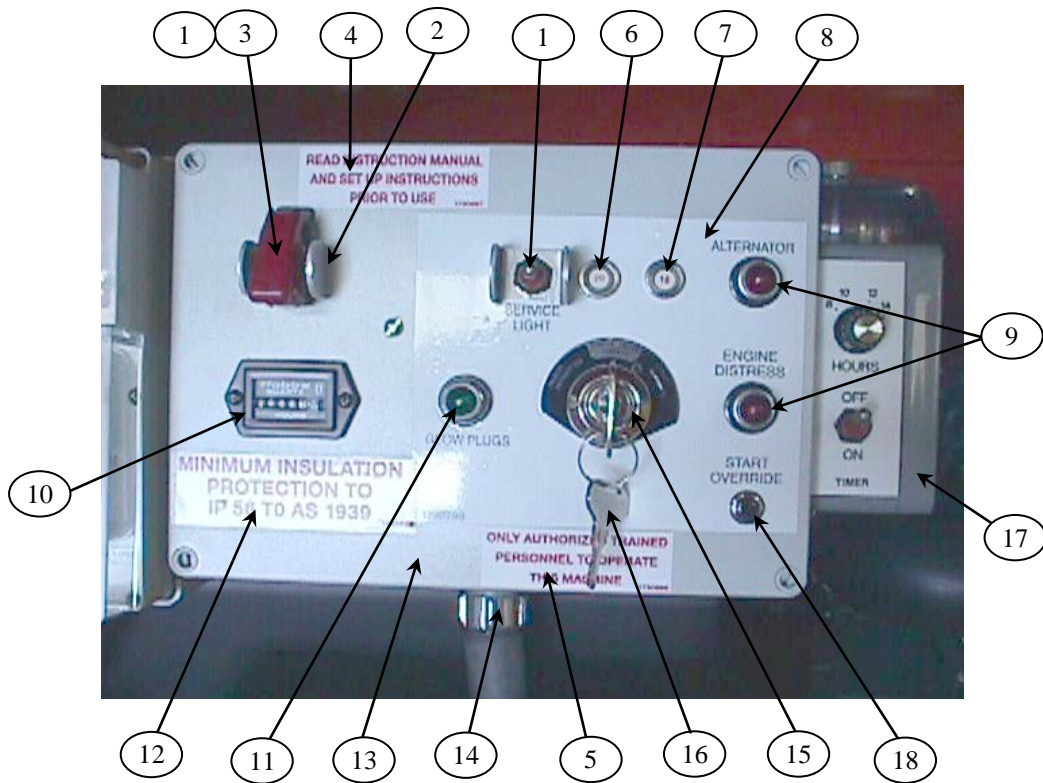

Item	Part Number	Qty	Description of Part
1	4360199	2	Toggle Switch SPST
2	4060229	1	Shield Toggle Switch
3	4360141	1	Emergency Stop Switch Guard
4	1730597	1	Decal 'Read Instruction Manual'
5	1730596	1	Decal 'Authorised Trained Personnel'
6	4360070	1	Circuit Breaker 15 Amp Push to Reset
7	4360161	1	Circuit Breaker 20 Amp Push to Reset
8	1730537	1	Decal Control Panel (Prior to S/N 6308AN081)
	1730798	1	Decal Control Panel (S/N 6308AN081 to Present)
9	2920026	2	Lamp Red
	2920029	2	Lamp Bulb
10	2420165	1	Hourmeter Gauge (Prior to S/N 6308AN1734)
	2420172	1	Hourmeter Gauge (S/N 6308AN1734 to present)
11	2920027	1	Lamp Green
	2920029	1	Lamp Bulb
12	1730538	1	Decal 'Minimum Insulation Protection'
13	1001146366	1	Enclosure Engine Control
14	4460051	1	Terminal Gland Connector
15	1730540	1	Ignition KeySwitch+Keys Control Box Kubota (option)
	1732656	1	Ignition KeySwitch+Keys Control Box Lucas (option)
	1734435	1	Ignition KeySwitch+Keys Control Box Perkins (option)
16	1730541	1	Ignition Key - Control Box Kubota Engine (option)
	1730550	1	Ignition Key - Control Box Perkins Engine (option)

17	1730700	1	Engine Shutdown Timer 14 HR (Option)
	1730674	1	Decal, Shutdown Timer 14 HR
	1734141	1	Engine Shutdown Timer 16 HR (Option)
	1734142	1	Decal, Shutdown Timer 16 HR
18	1730800	1	Override Switch (Prior to S/N 6308AN081)
Other 12V DC Components (Not Shown)			
	1730787	1	Engine Distress Shutdown Module (Inside Box) (Prior to S/N 6308AN303)
	1730924	1	Engine Distress Shutdown Module (Grey Box) (S/N 6308AN303 to Present)
	1735347	1	Terminal strip located inside box
	1730542	1	Glow Plug Timer Module
	3740086	1	Start Lockout Relay
	3740085	1	Start Lockout Relay Base
	1734099	1	Start Override Relay Kit (Later machines without start override switch.)
	1737268	1	Interior Service Light
	1733979	1	Interior Service Light Bulb

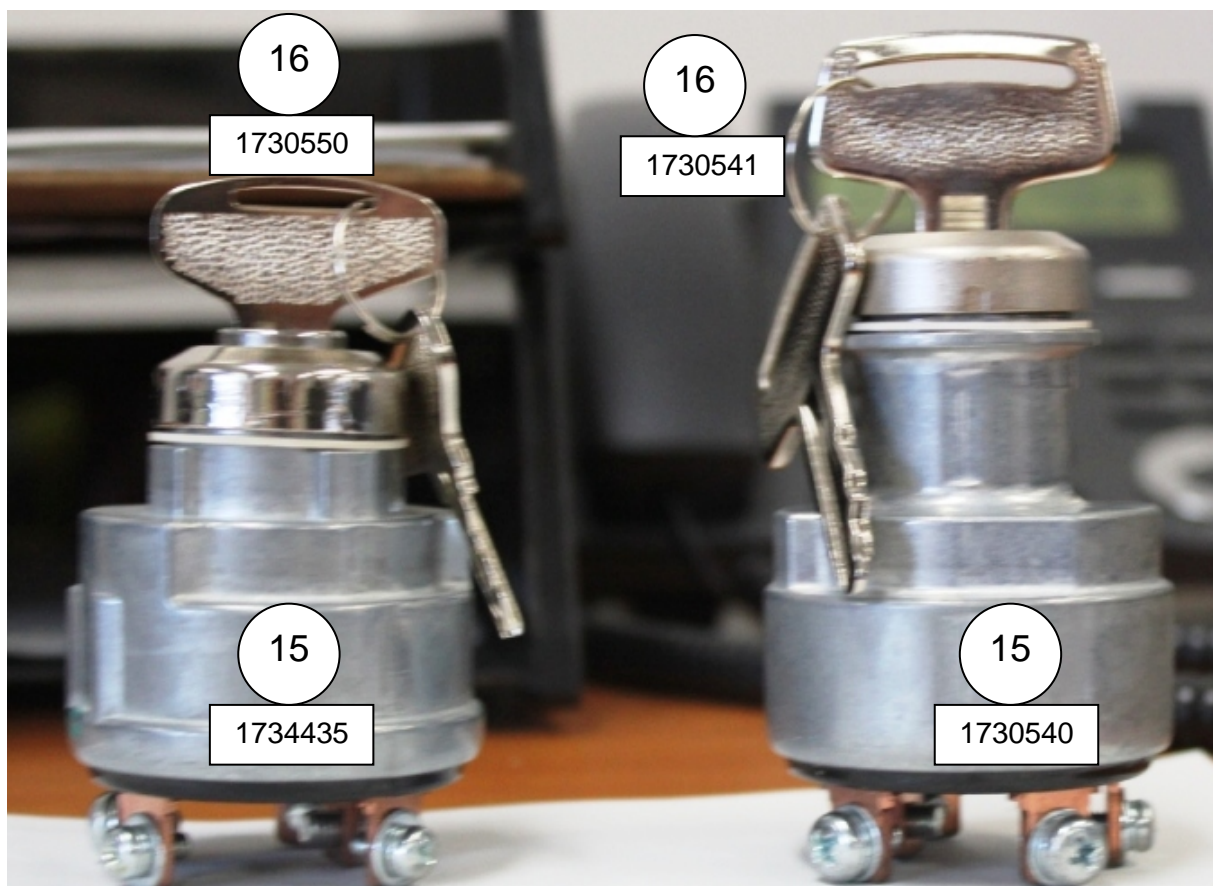

Engine Ignition Switch and Key- Identification

KUBOTA ENGINE - LEFT SIDE

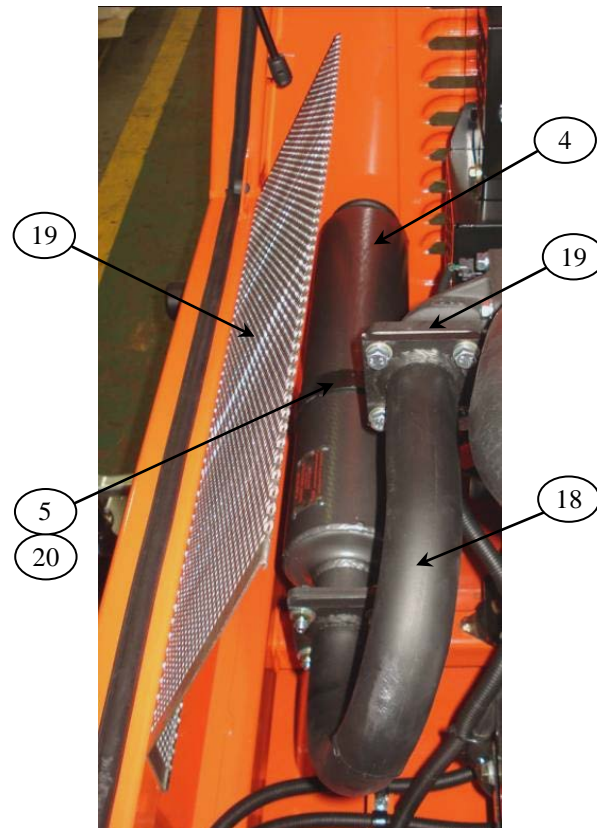
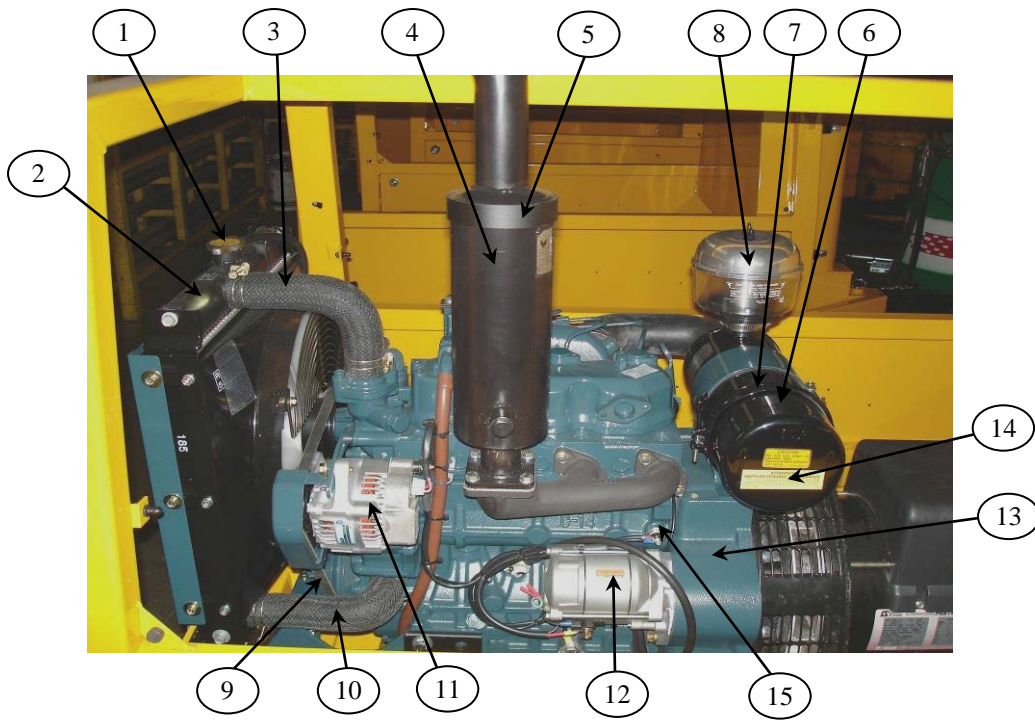

Series II

Item	Part Number	Qty	Description of Part
1	1730562	1	Radiator Cap Overflow. Carparts N1000
2	1730865	1	Radiator D1403
3	1730867	1	Radiator Hose Top D1403
4	1730765	1	Muffler Spark Arrestor
5	1730817	1	Muffler Support Clamp Stainless
	1734334	1	Muffler Clamp
6	1730869	1	Air Filter Assembly D1403
7	1730565	1	Air Filter Element D1403
8	1730768	1	Pre-cleaner Fleetguard (Donaldson)
9	1730870	1	Fan Belt D1403
	1734836	1	Fan Belt Guard Upper (Option)
	1734835	1	Fan Belt Guard Lower (Option)
10	1730868	1	Radiator Hose Lower D1403
11	1730558	1	Alternator 12V Denso
12	1730871	1	Starter Motor D1403
13	1730725	1	Engine Kubota D1403
14	1730947	1	Decal Muffler Periodic Maintenance
15	1730874	1	Oil Pressure Sender D1403
16	1730724	1	Rain Cap, Standard Muffler (Not Shown)
17	1733520	1	Exhaust Gasket
18	1733290	1	Rear Exhaust Pipe Kubota (Series II only)
19	1734178	1	Exhaust Deflector Shield Plate (Series II only)
20	1733329	1	Muffler Bracket Kubota Rear Exhaust (Series II only)

This page left blank intentionally

KUBOTA ENGINE – RIGHT SIDE

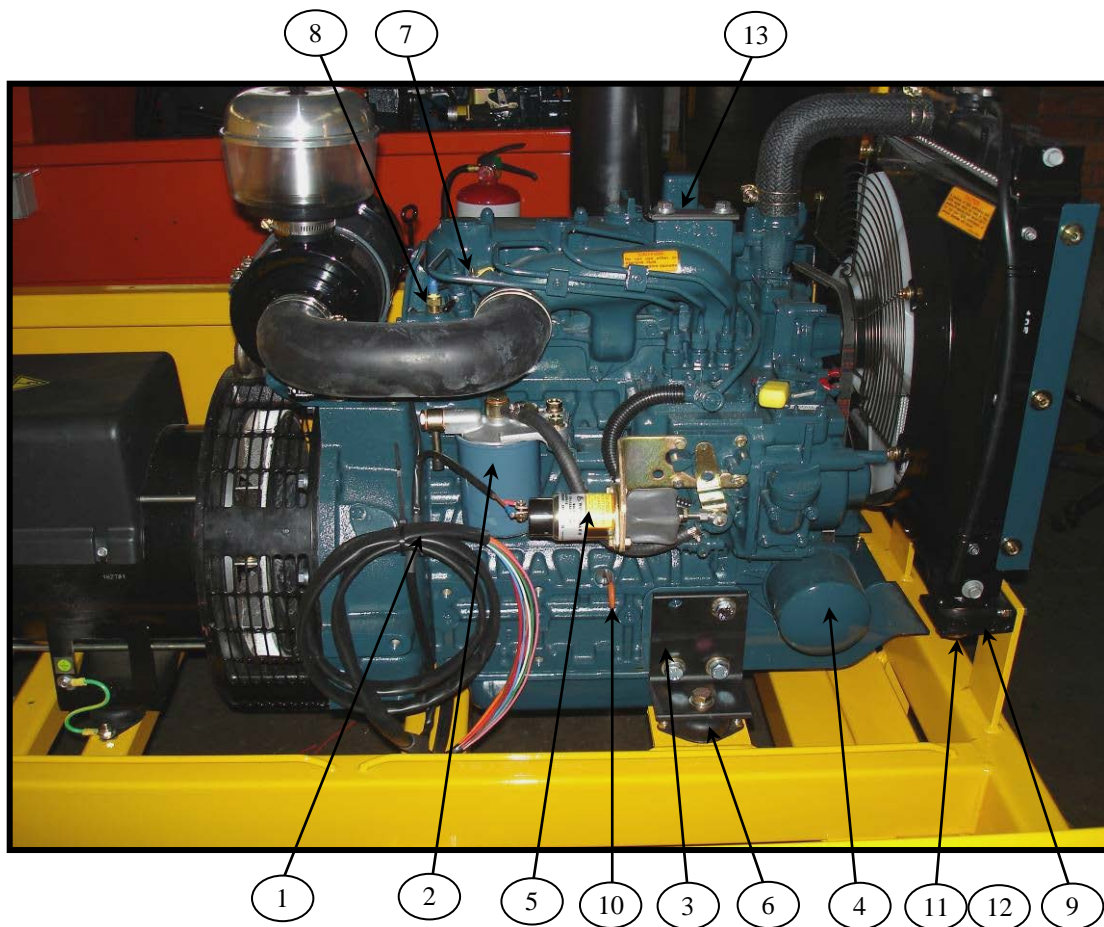

Item	Part Number	Qty	Description of Part
1	1730567	1	Engine Loom Kubota
2	1730873	1	Filter Fuel D1403
3	1730742	2	Engine Mount Left & Right suit D1403
4	1730569	1	Filter Oil
5	3740074	1	Solenoid Engine Run
6	1730211	4	Rubber Mount, Engine & Generator
	1730595	6	Rubber Mount, Engine & Generator (MeccAlte only)
7	1730875	3	Glow Plugs D1403
8	1730796	1	Engine Temperature Sender D1403
9	1734130	2	Bracket Radiator Mount
10	1730907	1	Engine Dipstick
11	1734127	2	Radiator Mount Top
12	1734126	2	Radiator Mount Bottom
13	1734335	1	Muffler Bracket Upright Kubota (Series I only)

PERKINS ENGINE - LEFT SIDE

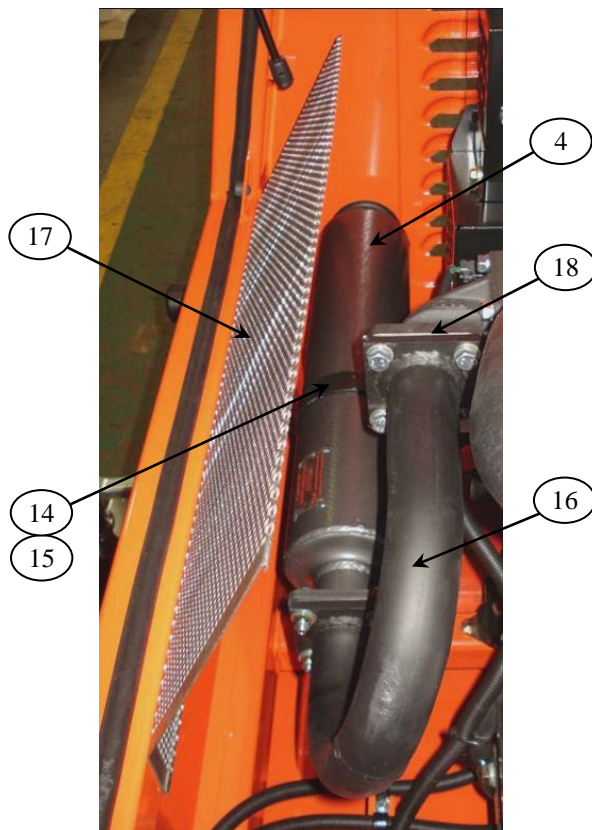
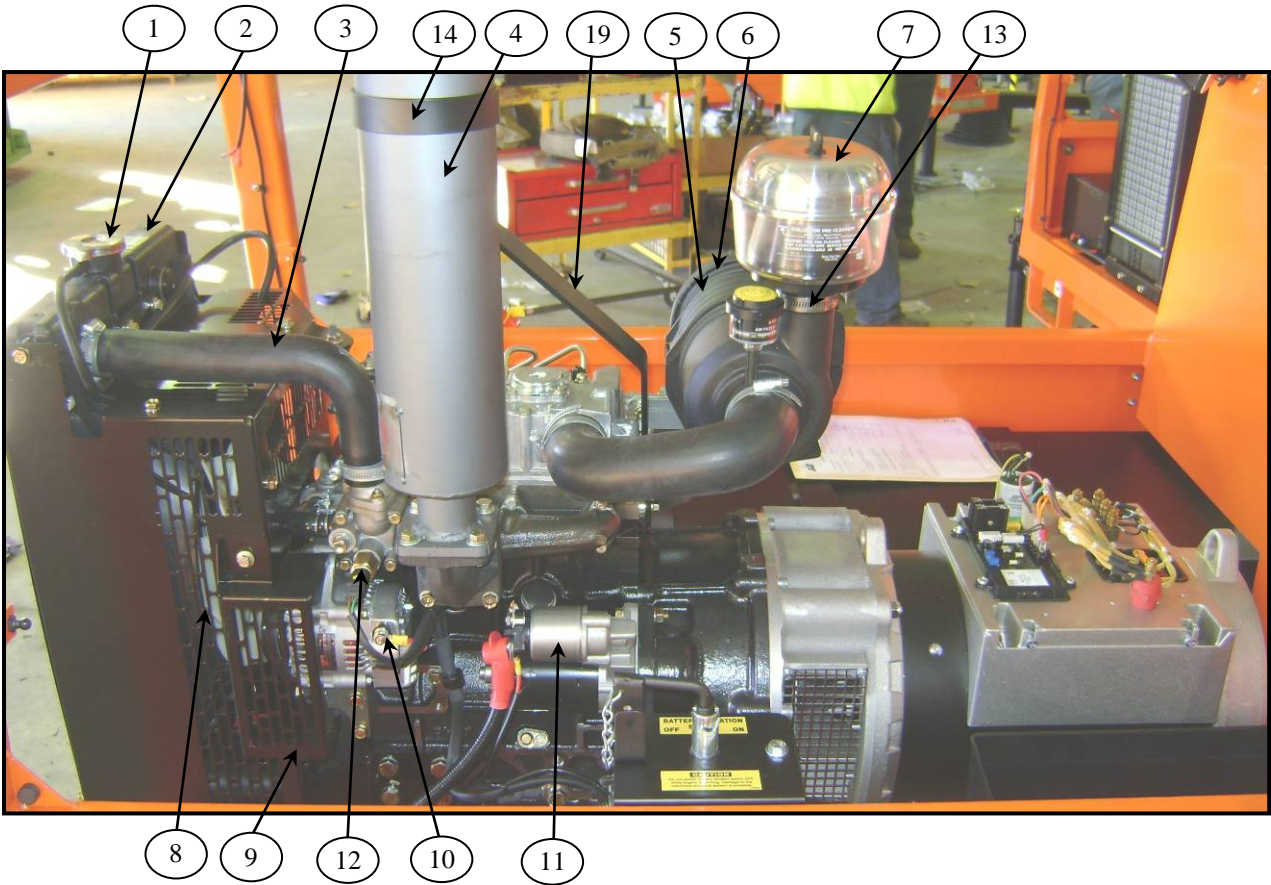

Series II

Item	Part Number	Qty	Description of Part
1	1731748	1	Radiator Cap Overflow
2	1734421	1	Radiator
3	1734422	1	Radiator Hose Top
4	1730765	1	Muffler Spark Arrestor
5	1734436	1	Air Filter Assembly
6	1734415	1	Air Filter Element
7	1730768	1	Pre-cleaner
8	1734153	1	Fan Belt
9	1734423	1	Radiator Hose Lower
10	1734385	1	Alternator
11	1734382	1	Starter Motor
12	1734381	1	Water Temperature Sender
13	1731350	1	Joiner Rubber Coupling
14	1734334	1	Muffler Clamp
15	1734177	1	Muffler Bracket Perkins Rear Exhaust (Series II only)
16	1734176	1	Rear Exhaust Pipe Perkins (Series II only)
17	1734178	1	Exhaust Deflector Shield Plate (Series II only)
18	1733520	2	Exhaust Gasket (1 for Series I machines)
19	1734336	1	Perkins Muffler Bracket Upright (Series I only)

This page left blank intentionally

PERKINS ENGINE – RIGHT SIDE

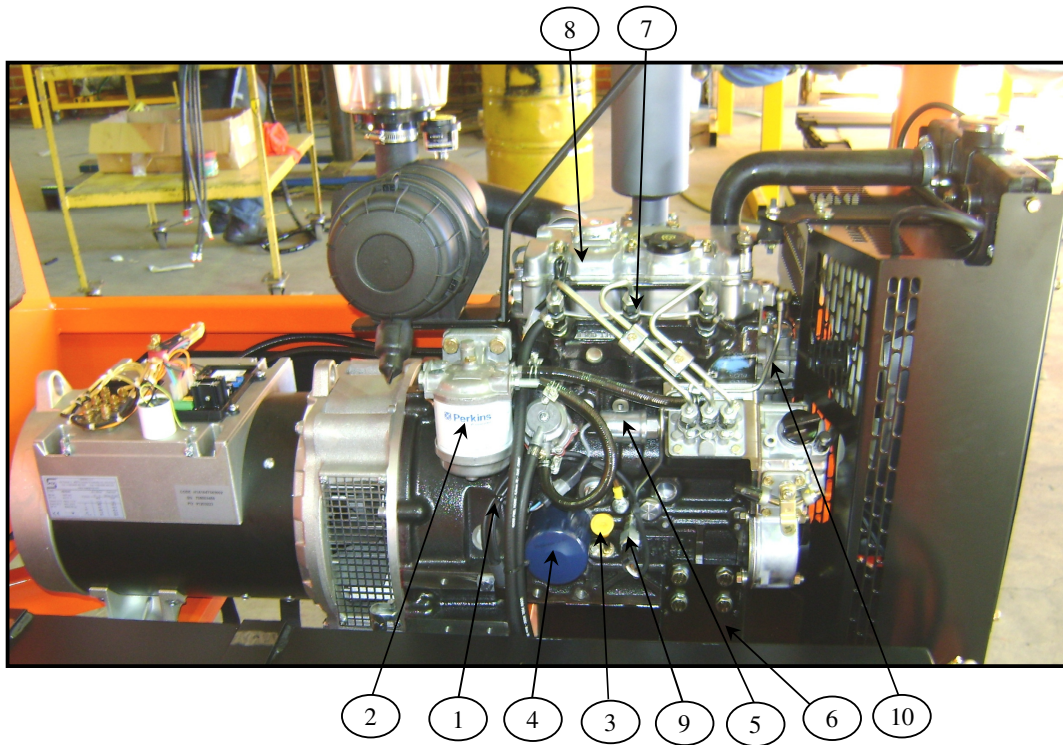

Item	Part Number	Qty	Description of Part
1	1734386	1	Engine Loom
2	1733164	1	Filter Fuel
3	1734383	1	Engine Dipstick
4	1733165	1	Filter Oil
5	1734424	1	Solenoid Engine Run
6	1730211	4	Rubber Mounts
7	1734384	3	Glow Plugs
8	1731747	1	Perkins Engine 403D11
9	1734420	1	Oil Pressure Sender
10	1734425	1	Water Pump
11	1001213257 1001213389	A/R	Kit, Perkins Radiator Mount MR40 Instructions, Retrofit Radiator Mounts (403D Engine)

ALTERNATOR, BATTERY & BATTERY ISOLATOR SWITCH



Item	Part Number	Qty	Description of Part
1	0400003	1	Battery 12 Volt N70ZZ
2	1730727	1	Battery Clamp
3	1731207	1	Battery Tray Standard
4	1730861	1	Battery Box
5	1738283	1	Terminal Battery Lug Positive
6	1734112	1	Battery Terminal Boot Red
7	1738284	1	Terminal Battery Lug Negative
8	1734113	1	Battery Terminal Boot Black
9	1730572	1	Alternator, MeccAlte. Model CT03-2L/4
	1730213	1	Alternator, Sincro 14kVA HB45AR (Kubota)

	1731750	1	Alternator, Sincro 14kVA HB45AR (Perkins)
	1730251	1	Alternator, Leroy Somer
	1730253	1	Alternator, Sincro 16.5kVA
10	1734125	1	AVR Card, Sincro
	1734080	1	AVR Card, Leroy Somer
11	1734109	1	Compound Regulator (MeccAlte)
12	4360155	1	Battery Isolator Switch, Single Pole
	1730847	1	Battery Isolator Switch, Double Pole
13	1730672	1	Bracket, Single Pole Battery Isolator Switch
	1730848	1	Bracket, Double Pole Battery Isolator Switch
14	1734117	1	Single Pole Isolator Lockable Head
15	1733272	1	Double Pole Isolator Handle Weldment
16	1733269	1	Double Pole Battery Isolator Bracket
17	1731126	1	Double Pole Isolator Locking Bracket (Locksafe) (Option)
18	1730772	1	Decal, Battery Isolator Switch
19	1730913	1	Decal, Caution Battery Isolator
20	2400044	1	200A Fuse Holder
21	2400041	1	200A Fuse, Motor Starter Supply
22	1733220	1	25mm to 25mm 90deg Adapter
23	1733733	1	Cole Hersee Heavy Duty Starter Assembly (Option)
24	4460618	1	Terminal Anderson 350Amp (Option)
25	1737908	1	EMC Filter (Capacitor)
Other Components Not Shown			
	1730832	1	Decal 'MEN Point' Alternator Cover (option)
	1730850	8	Red 8mm Terminal Boot
	1730851	4	Black 8mm Terminal Boot
	1730878	3	Red 6mm Terminal Boot
	1730879	1	Red 5mm Terminal Boot
	1730880	1	Black 5mm Terminal Boot

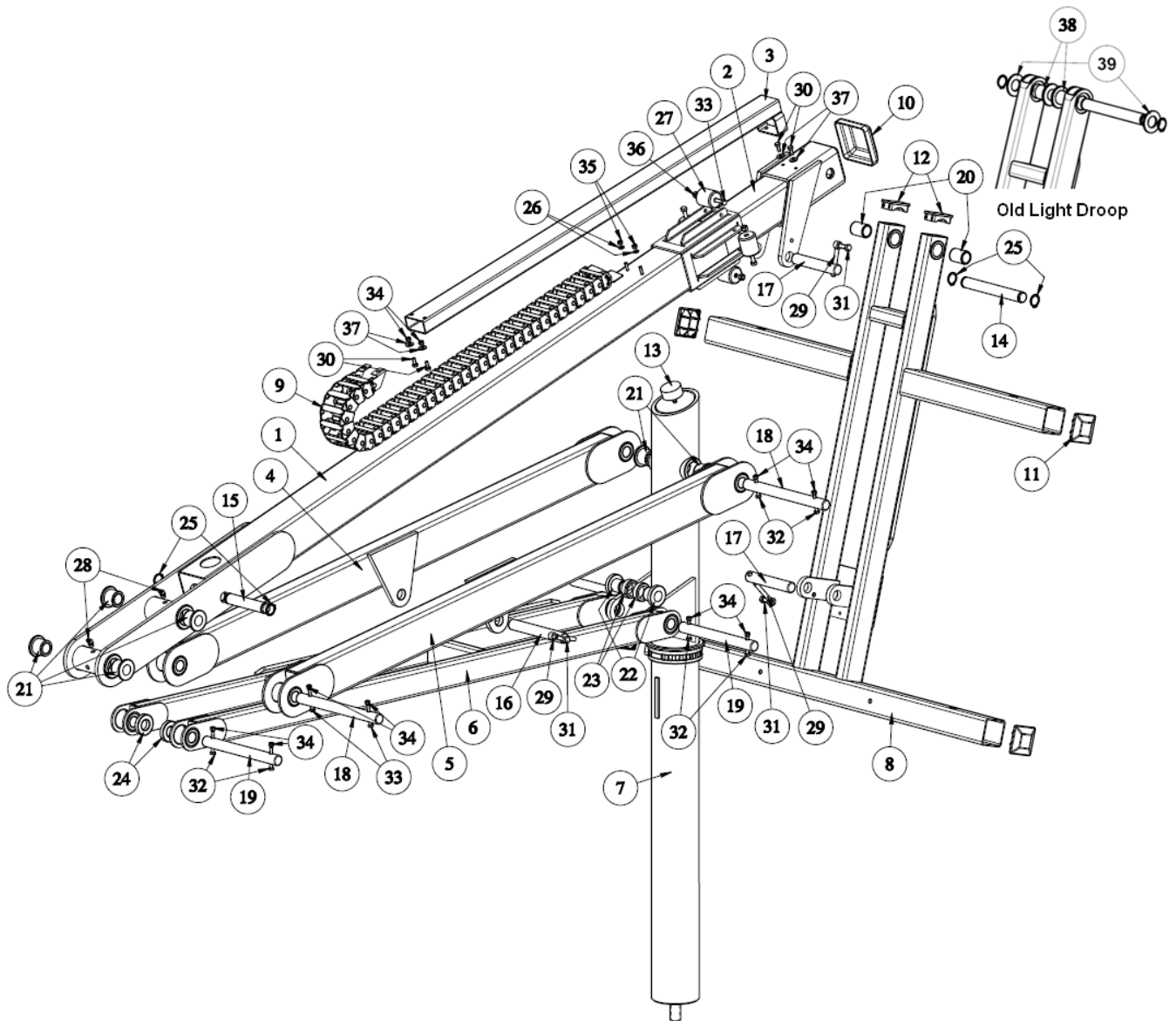
MAST ASSEMBLY

Item	Part Number	Qty	Description of Part
1	1730517	1	Weldment, Mast Upper External
	1734106	1	Weldment, Mast Upper External (Stauff Clamp Spec)
2	1730516	1	Assembly, Mast Upper Inner
3	1730589	1	Weldment, Cable Carrier Tube
4	1730514	1	Weldment, Inner Link Arm LH
5	1734352	1	Weldment, Inner Link Arm RH
6	1730515	1	Weldment, Outer Link Arms
	1734105	1	Weldment, Outer Link Arms (Stauff Clamp Spec)
7	1730661	1	Weldment, Lower Inner Mast
8	1734190	1	Weldment, Light Droop MKII
9	1734586	1	Assembly, Cat Track
10	1730814	1	Cap, Inner Mast Galvanize
11	1730812	4	End Cap, Light Bar 65x65
12	1731360	2	End Cap, Light Bar 65x35 (Scalloped)
13	1730778	1	Rubber Bumper, Mast Park
14	1001173862	1	Pin, Light Droop Pivot

15	1001173863	1	Pin,Tilt Cylinder Lower Pivot
16	1001173774	1	Pin, Lift Cylinder Pivot
17	1001173864	2	Pin, Tilt Cylinder Pivot
18	1001173773	2	Pin, Inner Link Arm Pivot
19	1001173772	2	Pin, Outer link Arm Pivot
20	1731306	2	Bush, Light Droop MKII
21	1730511	2	Bush, Mast Upper Brass
22	1730513	2	Boss, Cylinder to Lower Mast
23	1730614	1	Pin, SS 1" Dia. 185mm Long
24	1734299	2	Spacer, Double Pivot
25	7011716	4	Ring Snap, Pedal Retaining
26	4811700	2	Washer, 6mm
27	1730710	4	Roller, Mast Carrier
28	1731087	2	Fitting, Grease , 45 Deg. 1/8 NPT
29	3841143	3	Keeper, 3/8" Shaft
30	0641405	4	Hex Hd Cap Screw, 1/4-20 x 5/8 LG
31	0641608	3	Hex Hd Cap Screw, 3/8-16 x 1 LG
32	0641416	6	Hex Hd Cap Screw, 1/4-20 x 2 LG
33	0641522	4	Hex Hd Cap Screw, 5/16-18 x 2 3/4 LG
34	1734309	10	Nut, Nyloc 1/4
35	3290605	2	Nut, Nyloc M6 x 1 TPI ZP
36	1734471	4	Nut, Nyloc 5/16
37	4751400	4	Washer, 1/4 Dia. Plain Stl., Wide
38	1730615	2	Bush, Mast Upper Inner (Old Light Droop)
39	1734053	1	Washer, 1" Plain Stl., Narrow (Old Light Droop)
Other Mast Assembly Components (Not Shown)			
	1702009	3	Decal 'JLG' 3 1/2"
	1730521	24	Conduit Clamp, Plastic (option)
	1735514	14	Stauff Clamp, 2 x 12mm Plastic (option)
	1737913	5	Stauff Clamp, Steel Plate (option)
	1737914	5	Stauff Clamp, Base Plate (option)

CYLINDERS



2 Bale Cylinder (Pin Eye Welded to Rod) 3

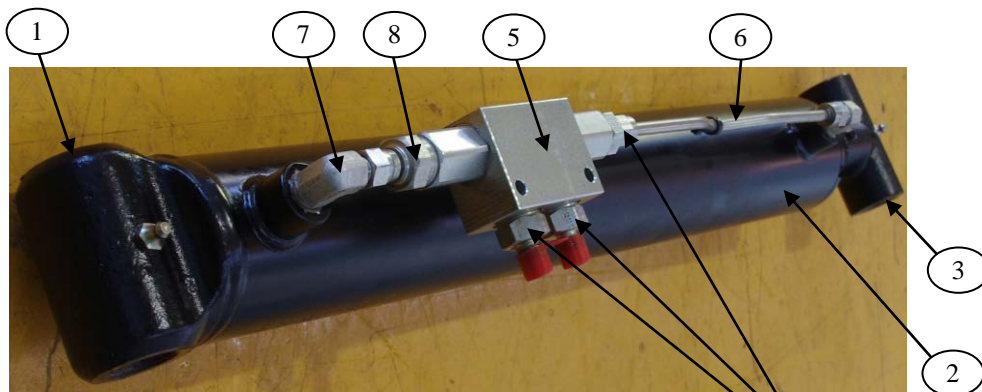

Nordon Cylinder (Cast Pin Eye)

Lift Cylinder

Item	Part Number	Qty	Description of Part
1	1733233	1	Complete Lift Cylinder (Nordon)
2	1730839	1	Barrel – Lift Cylinder (Bale)
	1734220	1	Barrel – Lift Cylinder (Nordon)
3	1730840	1	Rod – Lift Cylinder (Bale)
	1734221	1	Rod – Lift Cylinder (Nordon)
4	1730841	1	Seal Kit – Lift/Tilt Cylinder (Bale) (Not Shown)
	1731355	1	Seal Kit – Lift/Tilt Cylinder (Nordon) (Not Shown)
5	1730634	1	Double Pilot Check Valve
6	1734156	1	Tube Lift Cylinder
7	1733343	2	Elbow M/M ¼ x 7/16
8	1733344	1	Straight Union Adaptor M/F ¼ x 7/16
9	1734248	3	Nipple M/M with Encapsulated Seal ¼ x 7/16

Tilt Cylinder

Item	Part Number	Qty	Description of Part
1	1733234	1	Complete Tilt Cylinder (Nordon)
2	1730845	1	Barrel – Tilt Cylinder (Bale)
	1734222	1	Barrel – Tilt Cylinder (Nordon)
3	1730846	1	Rod – Tilt Cylinder (Bale)
	1734223	1	Rod – Tilt Cylinder (Nordon)
4	1730841	1	Seal Kit – Lift/Tilt Cylinder (Bale) (Not Shown)
	1731355	1	Seal Kit – Lift/Tilt Cylinder (Nordon) (Not Shown)

5	1730634	1	Double Pilot Check Valve
6	1734155	1	Tube Tilt Cylinder
7	1733343	2	Elbow M/M ¼ x 7/16
8	1733344	1	Straight Union Adaptor M/F ¼ x 7/16
9	1734248	3	Nipple M/M with Encapsulated Seal ¼ x 7/16



Bale Cylinder (Pin Eye Welded to Rod)

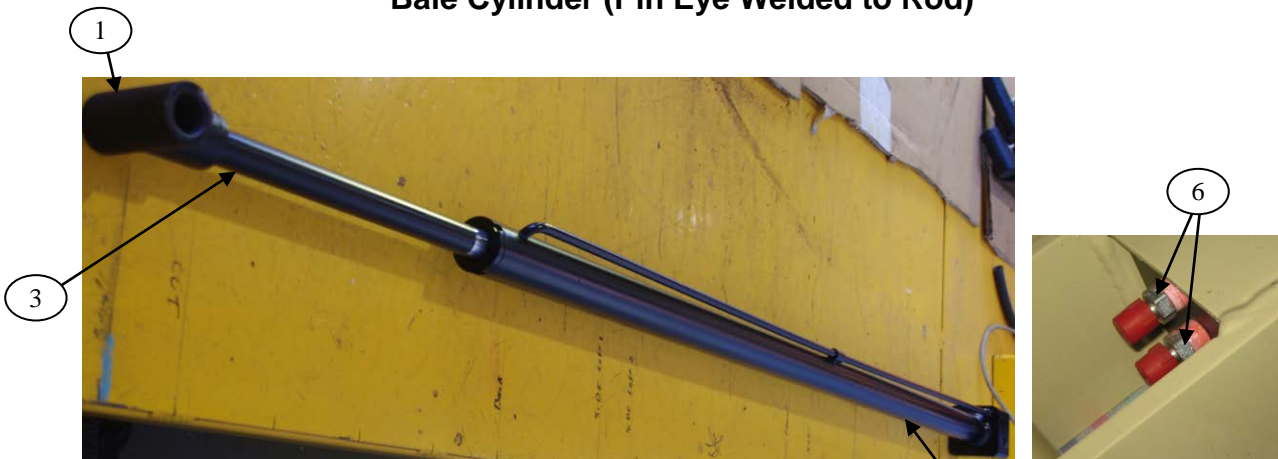

Nordon Cylinder (Cast Pin Eye)

Tele Cylinder

Item	Part Number	Qty	Description of Part
1	1733235	1	Complete Tele Cylinder (Nordon)
2	1730842	1	Barrel – Tele Cylinder (Bale)
	1734224	1	Barrel – Tele Cylinder (Nordon)
3	1730843	1	Rod – Tele Cylinder (Bale)
	1734225	1	Rod – Tele Cylinder (Nordon)
4	4640438	1	Check Valve
5	1730844	1	Seal Kit – Tele Cylinder (Bale)
	1731356	1	Seal Kit – Tele Cylinder (Nordon)
6	1733345	2	Nipple M/M ¼ x 7/16

This page left blank intentionally

LIGHT BAR ASSEMBLY



Item	Part Number	Qty	Description of Part
1	1730834	1	Clipsal Junction Box with Lid CL156JBIGY
	1733288	1	Metal Junction Box Finished
2	1730746	5	Adaptasteel Terminator Straight SP20-M20-M
	1730862	5	Earth Tag Ring for Steel Conduit Swivel Fitting (Option)
3	1733740	1	Neutral Link, 5 Holes (Inside Junction Box)
4	1730487	2	Long Conduit Assembly (Prior to S/N 6308AN1784)
5	1730486	2	Short Conduit Assembly (Prior to S/N 6308AN 1784)
6	1734219	4	Light Conduit Assembly (S/N 6308AN1784 to Present)
7	1730250	1	Mast AC Harness Assembly

FLOODLIGHT ASSEMBLY

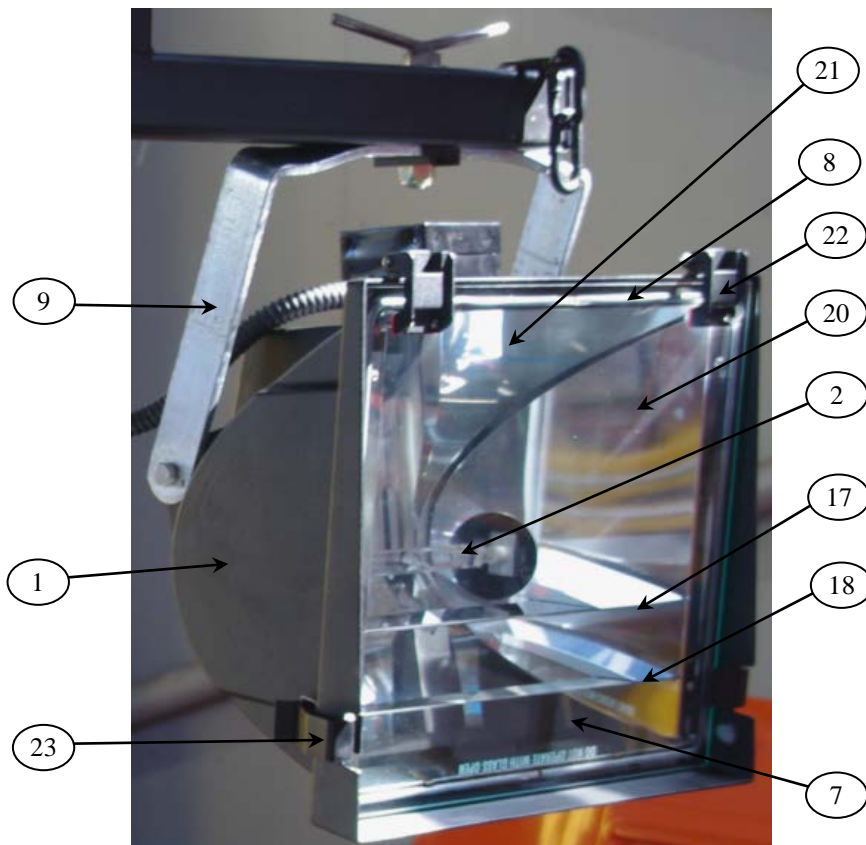

Item	Part Number	Qty	Description of Part
1	1730584	4	Sylvania Briteline Metal Halide Lamp Assembly
2	1730585	4	Metal Halide 1500 Watt Lamp Briteline MW1500T7
3	1730588	4	Ballast Transformer CWBL 1500-2-FL 240V 50HZ
		4	Ballast Transformer (New Style)
4	1730224	8	Capacitor. 20 Microfarad 525V AC
	1734021	8	Ballast Capacitor (New Style)
5	1730586	4	Ballast Assembly Complete (Control Gear)
6	1730587	4	Capacitor 250V AC 100 Nanofarad
7	1730921	4	Replacement Glass Lens
8	1734139	8	Light Assembly Gasket
9	1730362	4	Light Triunion
10	1734089	4	Light Mesh Guard (Option)
11	1730519	4	T-bar Bolt, Lamp Bracket Mount 3/4" x 4" UNC
12	1734230	4	Nut Retaining Bracket Finished
13	1732316	1	Nylatron Pad Strip 45mm Wide
14	1730759	4	Eye Bolt
15	1730758	4	Ring 75mm
16	1320224	5	Hose Clamp 5/8" Steel P Clip
17	1734030	4	Bottom Louvre
18	1734031	4	Top Louvre
19	1734032	4	L/H Reflector
20	1734033	4	R/H Reflector
21	1734034	4	Main Reflector
22	1734154	8	Hinge IP54
23	1734164	8	Latch Replacement Set IP54

OTHER CHASSIS COMPONENTS

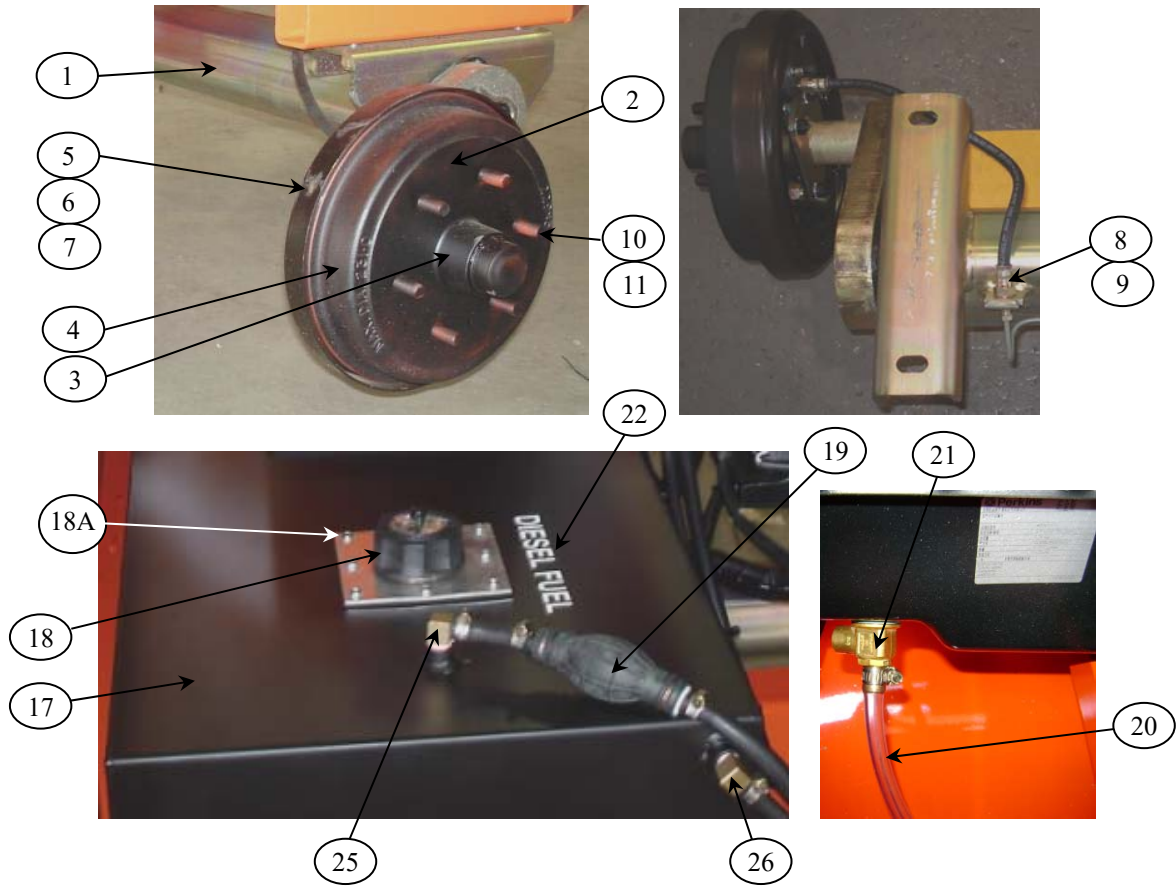

Item	Part Number	Qty	Description of Part
1	1730891	1	Axle Assembly 1650kg C/W Brakes (Alko)
	1730573	1	Axle Assembly 1900kg C/W Brakes (Vehicle Components)
2	1730825	2	Brake Drum Hub (superseded by 1001249150)
	1001249150		Brake, 9SL H/Drum (C/W hub bearings)
3	1730915	2	Wheel Bearing Set (Seal, Dust Cap and Split Pin)
4	1730577	2	Brake Shoe Set
5	1734097	2	Backing Plate RH (Vehicle Components)
6	1730883	2	Backing Plate LH (Vehicle Components)
7	1734486	2	Backing Plate Pair (Alko)
8	1730884	2	Bleed Nipple
9	1730882	2	Brake Wheel Cylinder (9" Drum)
10	1730885	12	Wheel Stud
11	1730886	12	Wheel Nut
12	1730887	2	Dust Cap
13	1730888	2	3/4" UNF Nut Bearing Retainer
14	1730889	2	3/4" Washer
15	1730890	2	3.2 x 32 Split Pin
16	1730920	2	Wheel Bearing Seal
17	1733282	1	Fuel Tank Finished
18	1730898	1	Fuel Gauge and Cap
18A	1733318	A/R	Filler Neck (for Fuel Tank 1730579)
	3911010	8	Round Head Screw 10-24 x 5/8"long
	1733510	A/R	Gasket, Filler Neck
19	1730815	1	Fuel Line Primer Bulb Pump

6308AN

20	1733314	1	Tube, Engine Oil Drain	
21	4641272	1	Valve, Oil Drain	
22	1700200	1	Decal 'Diesel Fuel'	
23	1320043	2	Hose Clamp 1/4" Steel P Clip	
24	1320061	5	Hose Clamp 3/4" Steel P Clip	
25	1730939	1	Brass Hosetail 1/4 BSPT x 1/4 Hose	
26	1730940	1	Brass Hosetail 1/4 BSPT x 3/8 Hose	
27	1730766	1	Brake-Line Kit (for Axle 1730891)	
	1733808	1	Long Tube Draw Bar	} Included in the brake-line kit
	1733809	1	Short Tube (Left)	
	1733810	1	Short Tube (Right)	
	1733811	1	Tee-Connector	
	1733812	1	Flexible Hose Drawbar	
	1733813	2	Flexible Hose Side (320 mm long)	
	1733814		C' Clips	
	1001244947	A/R	Flexible Hose Side (420 mm long) in lieu of Hose 1733813	
28	1001148979	1	Brake-Line Kit (for Axle 1730573)	
	1001148976	1	Tube, Brake Line LH, VC Bunded	} Included in the brake-line kit
	1001148977	1	Tube, Brake Line RH, VC Bunded	
	1001148978	2	Hose Assembly, Brake Line, VC Bunded	
	1733811	1	Tee-Connector (6308AN Brake Tube)	
	1733812	1	Hose Assembly, Drawbar (6308AN)	
	1733814	3	C-Clips (6308AN brake hose)	



AL-KO axle 1730891



Vehicle Components Axle 1730573

RADIATOR OVERFLOW BOTTLE AND MANUALS HOLDER

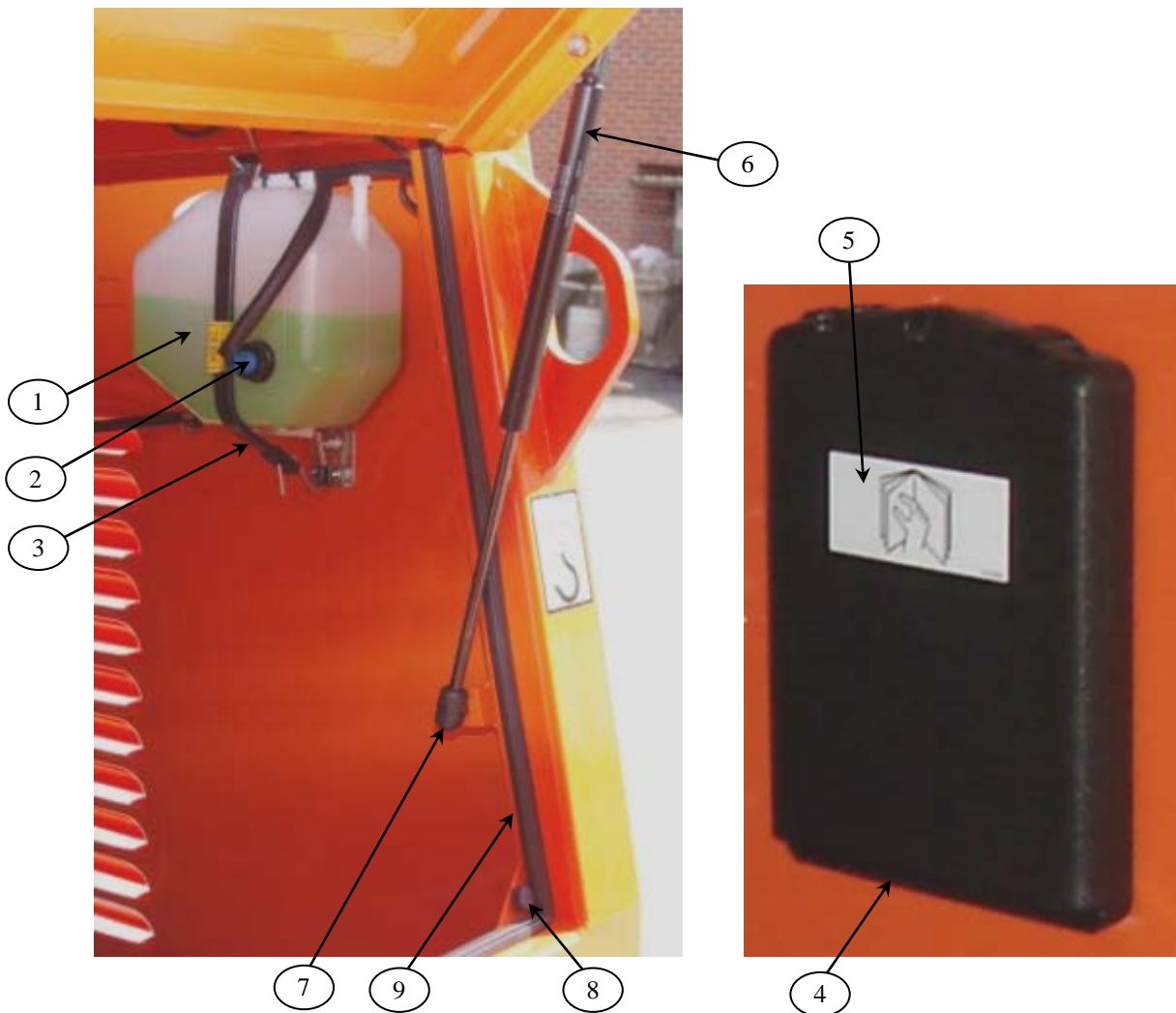

Item	Part Number	Qty	Description of Part
1	1730785	1	Overflow Bottle
2	1730918	1	Water Level Sensor
	1730919	1	Kit. Water Level Sensor Replacement (Converts Early Sensor Probe to Later Float Level Switch)
3	1730791	1	Rubber Strap
4	0860520	1	Box Manual Storage
5	1701509	1	Decal – Manual Storage Box
6	A330435	2	Gas Strut Door
7	A330437	2	Ball Stud for Gas Spring
8	0940036	5	Door Bumper Rubber
9	1734188	5	Door Rubber Seal

SECTION FOUR

RECOMMENDED SPARES

QUICK REFERENCE

ITEM DESCRIPTION	PART NO
Solenoid Pump Motor	1730549
Pushbutton Switch Pump	4360387
Main Breaker RCD	1730621
Switch Circuit breaker 10A Single Pole	1730622
Switch Circuit Breaker 10A Double Pole	1730197
Lamp Warning Green	2920027
Lamp Warning Red	2920026
Keyswitch Engine W/Key	1730540
Fan Belt (Kubota D1403)	1730870
Fan Belt (Perkins 403D-11)	1734153
Hose Radiator Top (Kubota D1403)	1730867
Hose Radiator Top (Perkins 403D-11)	1734422
Hose Radiator Lower (Kubota D1403)	1730868
Hose Radiator Lower (Perkins 403D-11)	1734423
Air Filter Element (Kubota D1403)	1730565
Air Filter Element (Perkins 403D-11)	1734415
Fuel Filter (Kubota D1403)	1730873
Fuel Filter (Perkins 403D-11)	1733164
Oil Filter (Kubota D1403)	1730569
Oil Filter (Perkins 403-11)	1733165
Bulb Metal Halide 1500 W	1730585
Bulb HPS 1000 W	1733266
Warning Lamp Bulb 12V	2920029
Switch Circuit Breaker 15ADC	4360070
Switch Circuit Breaker 20ADC	4360161

Note: Select the spare bulb (Metal Halide or HPS) to suit light-head type.

New Product Warranty

1. WARRANTY. JLG Industries (Australia), ("Manufacturer") warrants each new Lighting Tower product made by it to be free from defects in material or workmanship for TWELVE months from the date of initial sale of such product. Manufacturer agrees only to repair or replace at its own expense, F.O.B. the place or places of manufacture, any part or parts of the product found to be defective in material or workmanship, provided Manufacturer is notified of such defect or defects within the applicable warranty period and given a reasonable time to correct the defect. In no case shall any warranty extend to defects in materials, components, or services furnished by third parties. Defects caused by chemical action or the presence of abrasive materials and defects arising through the improper use or application of this Light Tower shall not be considered defects within the scope of the above mentioned warranty. If any repairs or alterations are made or any parts are replaced during the periods covered by any warranty above mentioned by other than an authorised Manufacturer's Distributor or authorised Service Agent in accordance with authorised Manufacturer's service manuals or with other than parts, accessories, or attachments authorised by Manufacturer for use in its products, customer shall pay for such repairs or parts without recourse against Manufacturer, and Manufacturer shall be relieved of responsibility for fulfilment of the above mentioned warranty with respect to parts or components for all repairs, alterations, or replacements so made. Manufacturer's obligations under this warranty shall at all times be subject to its then current warranty policies and procedures. The above mentioned warranty shall not apply to replacement or service parts made by and sold by the Manufacturer, with any obligation of the Manufacturer to such parts governed solely by Manufacturer's then current warranty policies and procedures.

2. DISCLAIMER AS TO CONSEQUENTIAL OR SPECIAL DAMAGES. Under no circumstances shall the Manufacturer be liable for any consequential or special damages which any person, firm, corporation, or other entity may suffer or claim to suffer or incur or claim to incur as a result of any defect in the product or in any correction or alteration thereof made or furnished by Manufacturer or others. "Consequential" or "special damages" as used herein includes but is not limited to costs of transportation, lost sales, lost orders, lost profits, lost income, loss of hire, increased overhead, labour and material costs, and costs of manufacturing variances and operational inefficiencies.

3. MAXIMUM LIABILITY. The maximum liability of Manufacturer under the exclusive warranty set forth herein shall be the amount paid to Manufacturer with respect to the product to which such warranty applies.

4. EXCLUSIVE AND ENTIRE WARRANTY. This warranty constitutes Manufacturer's entire warranty as to the product and it is agreed that the remedies of customer and those claiming under customer as stated in this warranty are exclusive. Manufacturer does not assume (and has not authorised any other person to assume on its behalf) any other warranty or liability in connection with any product covered by this warranty. MANUFACTURER EXPRESSLY DISCLAIMS ANY AND ALL OTHER WARRANTIES OF ANY KIND WHATSOEVER AS TO THE PRODUCT FURNISHED HEREUNDER, INCLUDING BUT NOT LIMITED TO EXPRESS OR IMPLIED WARRANTIES AS TO MERCHANTABILITY, FITNESS FOR PARTICULAR PURPOSES SOLD, DESCRIPTION OR QUALITY OF THE PRODUCT FURNISHED HEREUNDER.

5. NOTICE OF OCCURRENCE. This warranty shall be void if, upon the occurrence of any incident involving any product made by Manufacturer and resulting in any personal injury or property damage, customer shall fail to notify Manufacturer within 48 hours of such occurrence or permit Manufacturer and its representatives to have immediate access to such product and to all records of or within the control of customer relating to the product and occurrence.

6. LIMITATION OF LIABILITY. The limitation of liability provisions herein shall apply to any and all claims or suits brought against Manufacturer including any claim based upon negligence, breach of contract, breach of warranty, strict liability, or any other legal theories upon which liability may be asserted against Manufacturer.

Manufacturer may at any time amend the foregoing form of warranty without prior notice.