



An Oshkosh Corporation Company

---

# ***Operation and Safety Manual***

*Original Instructions - Keep this manual with the machine at all times.*

**Boom Lift Models**

**E300A**

**E300AJ**

**E300AJP**

**Prior to S/N 0300138358**



**3121214**  
*December 10, 2009*



## **FOREWORD**

This manual is a very important tool! Keep it with the machine at all times.

The purpose of this manual is to provide owners, users, operators, lessors, and lessees with the precautions and operating procedures essential for the safe and proper machine operation for its intended purpose.

Due to continuous product improvements, JLG Industries, Inc. reserves the right to make specification changes without prior notification. Contact JLG Industries, Inc. for updated information.

## SAFETY ALERT SYMBOLS AND SAFETY SIGNAL WORDS



This is the Safety Alert Symbol. It is used to alert you to the potential personal injury hazards. Obey all safety messages that follow this symbol to avoid possible injury or death

### **DANGER**

INDICATES AN IMMINENTLY HAZARDOUS SITUATION. IF NOT AVOIDED, WILL RESULT IN SERIOUS INJURY OR DEATH. THIS DECAL WILL HAVE A RED BACKGROUND.

### **WARNING**

INDICATES A POTENTIALLY HAZARDOUS SITUATION. IF NOT AVOIDED, COULD RESULT IN SERIOUS INJURY OR DEATH. THIS DECAL WILL HAVE AN ORANGE BACKGROUND.

### **CAUTION**

INDICATES A POTENTIALLY HAZARDOUS SITUATION. IF NOT AVOIDED, MAY RESULT IN MINOR OR MODERATE INJURY. IT MAY ALSO ALERT AGAINST UNSAFE PRACTICES. THIS DECAL WILL HAVE A YELLOW BACKGROUND.

**⚠ WARNING**

**THIS PRODUCT MUST COMPLY WITH ALL SAFETY RELATED BULLETINS. CONTACT JLG INDUSTRIES, INC. OR THE LOCAL AUTHORIZED JLG REPRESENTATIVE FOR INFORMATION REGARDING SAFETY-RELATED BULLETINS WHICH MAY HAVE BEEN ISSUED FOR THIS PRODUCT.**

**NOTICE**

**JLG INDUSTRIES, INC. SENDS SAFETY RELATED BULLETINS TO THE OWNER OF RECORD OF THIS MACHINE. CONTACT JLG INDUSTRIES, INC. TO ENSURE THAT THE CURRENT OWNER RECORDS ARE UPDATED AND ACCURATE.**

**NOTICE**

**JLG INDUSTRIES, INC. MUST BE NOTIFIED IMMEDIATELY IN ALL INSTANCES WHERE JLG PRODUCTS HAVE BEEN INVOLVED IN AN ACCIDENT INVOLVING BODILY INJURY OR DEATH OF PERSONNEL OR WHEN SUBSTANTIAL DAMAGE HAS OCCURRED TO PERSONAL PROPERTY OR THE JLG PRODUCT.**

**For:**

- Accident Reporting
- Product Safety Publications
- Current Owner Updates
- Questions Regarding Product Safety
- Standards and Regulations Compliance Information
- Questions Regarding Special Product Applications
- Questions Regarding Product Modifications

**Contact:**

Product Safety and Reliability Department  
JLG Industries, Inc.  
13224 Fountainhead Plaza  
Hagerstown, MD 21742

or Your Local JLG Office  
(See addresses on inside of manual cover)

**In USA:**

Toll Free: 877-JLG-SAFE (877-554-7233)

**Outside USA:**

Phone: 240-420-2661  
Fax: 301-745-3713  
E-mail: [ProductSafety@JLG.com](mailto:ProductSafety@JLG.com)

## **REVISION LOG**

Original Issue	- June 13, 2005
Revised	- July 12, 2006
Revised	- November 6, 2006
Revised	- May 7, 2007
Revised	- May 15, 2008
Revised	- December 10, 2009

<b>SECTION - PARAGRAPH, SUBJECT</b>	<b>PAGE</b>
<b>SECTION - 1 - SAFETY PRECAUTIONS</b>	
1.1 GENERAL . . . . .	1-1
1.2 PRE-OPERATION . . . . .	1-1
Operator Training and Knowledge . . . . .	1-1
Workplace Inspection . . . . .	1-2
Machine Inspection . . . . .	1-2
1.3 OPERATION . . . . .	1-3
General . . . . .	1-3
Trip and Fall Hazards . . . . .	1-3
Electrocution Hazards . . . . .	1-4
Tipping Hazards . . . . .	1-6
Crushing and Collision Hazards . . . . .	1-7
1.4 TOWING, LIFTING, AND HAULING . . . . .	1-8
1.5 ADDITIONAL HAZARDS / SAFETY . . . . .	1-9
<b>SECTION - 2 - USER RESPONSIBILITIES, MACHINE PREPARATION, AND INSPECTION</b>	
2.1 PERSONNEL TRAINING . . . . .	2-1
Operator Training . . . . .	2-1
Training Supervision . . . . .	2-1
Operator Responsibility . . . . .	2-1
2.2 PREPARATION, INSPECTION, AND MAINTENANCE . . . . .	2-2
Pre-Start Inspection . . . . .	2-4
Function Check . . . . .	2-5

<b>SECTION - PARAGRAPH, SUBJECT</b>	<b>PAGE</b>
GENERAL . . . . .	2-10
<b>SECTION - 3 - MACHINE CONTROLS AND INDICATORS</b>	
3.1 GENERAL . . . . .	3-1
3.2 CONTROLS AND INDICATORS . . . . .	3-1
Ground Control Station . . . . .	3-1
Platform Control Station . . . . .	3-7
Platform Control Indicator Panel . . . . .	3-11
<b>SECTION - 4 - MACHINE OPERATION</b>	
4.1 DESCRIPTION . . . . .	4-1
4.2 OPERATING CHARACTERISTICS AND LIMITATIONS . . . . .	4-1
Capacities . . . . .	4-1
Stability . . . . .	4-2
4.3 MOTOR OPERATION . . . . .	4-2
Power/Emergency Stop . . . . .	4-2
Platform/Ground Select Switch . . . . .	4-2
Motor Activation . . . . .	4-5
4.4 TRAVELING (DRIVING) . . . . .	4-5
Traveling Forward and Reverse . . . . .	4-6
4.5 STEERING . . . . .	4-6
4.6 PLATFORM . . . . .	4-6
Loading From Ground Level . . . . .	4-6
Loading From Positions Above Ground Level . . . . .	4-6

## TABLE OF CONTENTS

SECTION - PARAGRAPH, SUBJECT	PAGE	SECTION - PARAGRAPH, SUBJECT	PAGE
Platform Level Adjustment . . . . .	4-8	<b>MAINTENANCE</b>	
Platform Rotation . . . . .	4-8	6.1 INTRODUCTION . . . . .	6-1
4.7 BOOM . . . . .	4-8	6.2 OPERATING SPECIFICATIONS . . . . .	6-1
Swinging the Boom . . . . .	4-9	Capacities . . . . .	6-3
Raising and Lowering the Upper Boom . . . . .	4-9	Dimensional Data . . . . .	6-4
4.8 BOOM FUNCTION SPEEDS . . . . .	4-9	Hydraulic Oil . . . . .	6-4
4.9 SHUT DOWN AND PARK . . . . .	4-10	Critical Stability Weights . . . . .	6-6
4.10 LIFTING AND TIE DOWN . . . . .	4-10	Serial Number Locations . . . . .	6-6
Lifting . . . . .	4-10	6.3 OPERATOR MAINTENANCE . . . . .	6-8
Tie Down . . . . .	4-10	6.4 BATTERY MAINTENANCE AND CHARGING . . . . .	6-11
		Battery Maintenance, Quarterly . . . . .	6-11
<b>SECTION - 5 - EMERGENCY PROCEDURES</b>		Battery Charging, Daily . . . . .	6-12
5.1 GENERAL . . . . .	5-1	6.5 TIRES AND WHEELS . . . . .	6-13
5.2 INCIDENT NOTIFICATION . . . . .	5-1	Tire Wear and Damage . . . . .	6-13
5.3 EMERGENCY OPERATION . . . . .	5-2	Wheel and Tire Replacement . . . . .	6-13
Operator Unable to Control Machine . . . . .	5-2	Wheel Installation . . . . .	6-13
Platform or Boom Caught Overhead . . . . .	5-2	6.6 SUPPLEMENTAL INFORMATION . . . . .	6-14
5.4 EMERGENCY TOWING PROCEDURES . . . . .	5-2		
5.5 MANUAL DESCENT SYSTEM . . . . .	5-3	<b>SECTION - 7 - INSPECTION AND REPAIR LOG</b>	
Jib Manual Descent . . . . .	5-3		
Manual Swing Override . . . . .	5-3		
<b>SECTION - 6 - GENERAL SPECIFICATIONS &amp; OPERATOR</b>			



## TABLE OF CONTENTS

SECTION - PARAGRAPH, SUBJECT	PAGE	SECTION - PARAGRAPH, SUBJECT	PAGE
<b>LIST OF FIGURES</b>		<b>LIST OF TABLES</b>	
2-1. Boom Cutout Switches . . . . .	2-6	Minimum Approach Distances (M.A.D.) . . . . .	1-5
2-2. Basic Nomenclature - E300A . . . . .	2-7	Beaufort Scale . . . . .	1-9
2-3. Basic Nomenclature - E300AJ & E300AJP . . . . .	2-8	Inspection and Maintenance Table . . . . .	2-3
2-4. Daily Walk - Around Inspection (Sheet 1 of 3) . . . . .	2-9	Simultaneous Functions . . . . .	3-10
2-5. Daily Walk-Around Inspection - Sheet 2 of 3 . . . . .	2-10	E300A Decal Legend - Part 1 of 2 . . . . .	4-16
2-6. Daily Walk-Around Inspection - Sheet 3 of 3 . . . . .	2-11	E300A Decal Legend - Part 2 of 2 . . . . .	4-20
3-1. Ground Control Station - 300A . . . . .	3-2	E300AJ Decal Legend . . . . .	4-24
3-2. Ground Control Station - 300AJ . . . . .	3-3	E300AJP Decal Legend . . . . .	4-28
3-3. Ground Control Station - 300AJP . . . . .	3-4	Operating specifications - E300A . . . . .	6-1
3-4. Platform Control Console . . . . .	3-8	Operating specifications - E300AJ . . . . .	6-2
3-5. Platform Control Indicator Panel . . . . .	3-12	Operating specifications - E300AJP . . . . .	6-3
4-1. Position Of Least Forward Stability . . . . .	4-3	Capacities. . . . .	6-3
4-2. Position Of Least Backward Stability . . . . .	4-4	Dimensional Data . . . . .	6-4
4-3. Grade and Side Slopes . . . . .	4-7	Hydraulic Oil. . . . .	6-4
4-4. Lifting Chart . . . . .	4-11	Mobil DTE 11M Specs . . . . .	6-5
4-5. Machine Tie Down . . . . .	4-12	Mobilfluid 424 Specs . . . . .	6-5
4-6. Decal Installation - Sheet 1 of 3 . . . . .	4-13	Mobil EAL 224H Specs . . . . .	6-6
4-7. Decal Installation - Sheet 2 of 3 . . . . .	4-14	Critical Stability Weights . . . . .	6-6
4-8. Decal Installation - Sheet 3 of 3 . . . . .	4-15	Lubrication Specifications. . . . .	6-8
6-1. Operator Maintenance & Lubrication Diagram . . . . .	6-7	Wheel Torque Chart . . . . .	6-14
		Inspection and Repair Log . . . . .	7-1

## **TABLE OF CONTENTS**

---

**SECTION - PARAGRAPH, SUBJECT**

**PAGE**

**SECTION - PARAGRAPH, SUBJECT**

**PAGE**

**This page left blank intentionally.**

## SECTION 1. SAFETY PRECAUTIONS

### 1.1 GENERAL

This section outlines the necessary precautions for proper and safe machine operation and maintenance. For proper machine use, it is mandatory that a daily routine is established based on the content of this manual. A maintenance program, using the information provided in this manual and the Service and Maintenance Manual, must also be established by a qualified person and followed to ensure the machine is safe to operate.

The owner/user/operator/lessor/lessee of the machine should not operate the machine until this manual has been read, training is accomplished, and operation of the machine has been completed under the supervision of an experienced and qualified operator.

If there are any questions with regard to safety, training, inspection, maintenance, application, and operation, please contact JLG Industries, Inc. (“JLG”).

#### **WARNING**

**FAILURE TO COMPLY WITH THE SAFETY PRECAUTIONS LISTED IN THIS MANUAL COULD RESULT IN MACHINE DAMAGE, PROPERTY DAMAGE, PERSONAL INJURY OR DEATH.**

### 1.2 PRE-OPERATION

#### Operator Training and Knowledge

- Read and understand this manual before operating the machine.

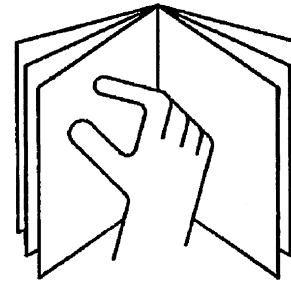

- Do not operate this machine until complete training is performed by authorized persons.
- Only authorized and qualified personnel can operate the machine.

## SECTION 1 - SAFETY PRECAUTIONS

---

- Read, understand, and obey all DANGERS, WARNINGS, CAUTIONS, and operating instructions on the machine and in this manual.
- Use the machine in a manner which is within the scope of its intended application set by JLG.
- All operating personnel must be familiar with the emergency controls and emergency operation of the machine as specified in this manual.
- Read, understand, and obey all applicable employer, local, and governmental regulations as they pertain to operation of the machine.

### Workplace Inspection

- The operator is to take safety measures to avoid all hazards in the work area prior to machine operation.
- Do not operate or raise the platform while on trucks, trailers, railway cars, floating vessels, scaffolds or other equipment unless approved in writing by JLG.
- Do not operate the machine in hazardous environments unless approved for that purpose by JLG.
- Be sure that the ground conditions are able to support the maximum load shown on the decals located on the machine.

- This machine can be operated in temperatures of 0° F to 104° F (-20° C to 40° C). Consult JLG for operation outside this range.

### Machine Inspection

- Before machine operation, perform inspections and functional checks. Refer to Section 2 of this manual for detailed instructions.
- Do not operate this machine until it has been serviced and maintained according to requirements specified in the Service and Maintenance Manual.
- Be sure the footswitch and all other safety devices are operating properly. Modification of these devices is a safety violation.

### WARNING

#### **MODIFICATION OR ALTERATION OF AN AERIAL WORK PLATFORM SHALL BE MADE ONLY WITH WRITTEN PERMISSION FROM THE MANUFACTURER**

- Do not operate any machine on which safety or instruction placards or decals are missing or illegible.
- Avoid any buildup of debris on the platform floor. Keep mud, oil, grease, and other slippery substances from footwear and platform floor.

### 1.3 OPERATION

#### General

- Do not use the machine for any purpose other than positioning personnel, their tools, and equipment.
  - Never operate a machine that is not working properly. If a malfunction occurs, shut down the machine.
  - Never slam a control switch or lever through neutral to an opposite direction. Always return switch to neutral and stop before moving the switch to the next function. Operate controls with slow and even pressure.
  - Do not allow personnel to tamper with or operate the machine from the ground with personnel in the platform, except in an emergency.
  - Do not carry materials directly on platform railing. Contact JLG for approved material handling accessories.
  - When two or more persons are in the platform, the operator shall be responsible for all machine operations.
  - Always ensure that power tools are properly stowed and never left hanging by their cord from the platform work area.
- Supplies or tools which extend outside the platform are prohibited unless approved by JLG.
  - When driving, always position boom over rear axle in line with the direction of travel. Remember, if boom is over the front axle, steer and drive functions will be reversed.
  - Do not assist a stuck or disabled machine by pushing, pulling, or by using boom functions. Only pull the unit from the tie-down lugs on the chassis.
  - Do not place boom or platform against any structure to steady the platform or to support the structure.
  - Stow boom and shut off all power before leaving machine.

#### Trip and Fall Hazards

During operation, occupants in the platform must wear a full body harness with a lanyard attached to an authorized lanyard anchorage point. Attach only one (1) lanyard per lanyard anchorage point.

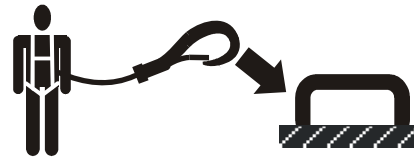

## SECTION 1 - SAFETY PRECAUTIONS

---

- Before operating the machine, make sure all gates are closed and fastened in their proper position.

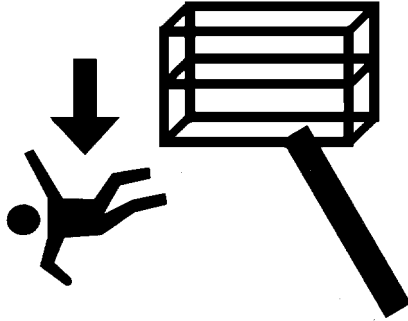

- Keep both feet firmly positioned on the platform floor at all times. Never use ladders, boxes, steps, planks, or similar items on platform to provide additional reach.
- Never use the boom assembly to enter or leave the platform.

- Use extreme caution when entering or leaving platform. Be sure that the boom is fully lowered. It may be necessary to telescope out to position the platform closer to the ground for entry/exit. Face the machine, maintain “three point contact” with the machine, using two hands and one foot or two feet and one hand during entry and exit.

### Electrocution Hazards

- This machine is not insulated and does not provide protection from contact or proximity to electrical current.

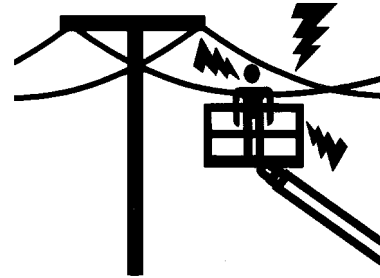

## SECTION 1 - SAFETY PRECAUTIONS

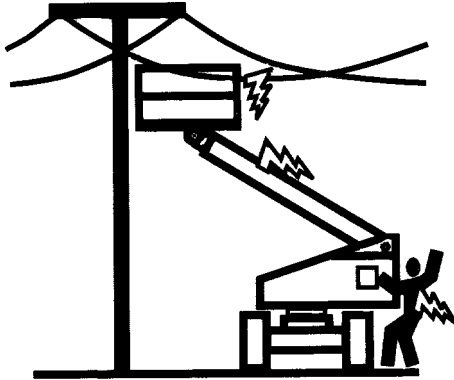

- Maintain distance from electrical lines, apparatus, or any energized (exposed or insulated) parts according to the Minimum Approach Distance (MAD) as shown in Table 1-1.
- Allow for machine movement and electrical line swaying.

Table 1-1. Minimum Approach Distances (M.A.D.)

Voltage Range (Phase to Phase)	MINIMUM APPROACH DISTANCE in Feet (Meters)
0 to 50 KV	10 (3)
Over 50KV to 200 KV	15 (5)
Over 200 KV to 350 KV	20 (6)
Over 350 KV to 500 KV	25 (8)
Over 500 KV to 750 KV	35 (11)
Over 750 KV to 1000 KV	45 (14)

**NOTE:** *This requirement shall apply except where employer, local or governmental regulations are more stringent.*

- Maintain a clearance of at least 10 ft. (3m) between any part of the machine and its occupants, their tools, and their equipment from any electrical line or apparatus carrying up to 50,000 volts. One foot additional clearance is required for every additional 30,000 volts or less.

## SECTION 1 - SAFETY PRECAUTIONS

---

- The minimum approach distance may be reduced if insulating barriers are installed to prevent contact, and the barriers are rated for the voltage of the line being guarded. These barriers shall not be part of (or attached to) the machine. The minimum approach distance shall be reduced to a distance within the designed working dimensions of the insulating barrier. This determination shall be made by a qualified person in accordance with the employer, local, or governmental requirements for work practices near energized equipment

### **⚠ DANGER**

**DO NOT MANEUVER MACHINE OR PERSONNEL INSIDE PROHIBITED ZONE (MAD). ASSUME ALL ELECTRICAL PARTS AND WIRING ARE ENERGIZED UNLESS KNOWN OTHERWISE.**

## Tipping Hazards

- The user must be familiar with the surface before driving. Do not exceed the allowable sideslope and grade while driving.

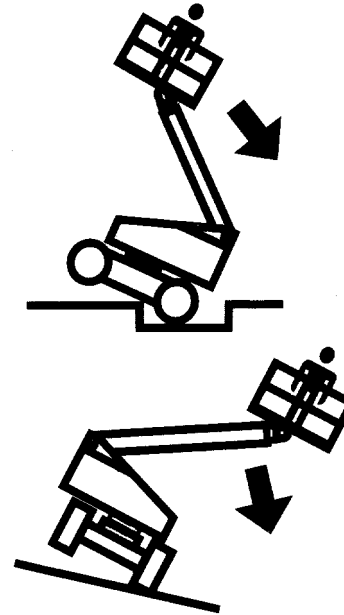



- Do not elevate platform or drive with platform elevated while on a sloping, uneven, or soft surface.
- Before driving on floors, bridges, trucks, and other surfaces, check allowable capacity of the surfaces.
- Never exceed the maximum platform capacity. Distribute loads evenly on platform floor.
- Do not raise the platform or drive from an elevated position unless the machine is on firm, level and smooth surfaces.
- Keep the chassis of the machine at least 2 ft. (0.6m) from holes, bumps, drop-offs, obstructions, debris, concealed holes, and other potential hazards on the floor/surface.
- Do not push or pull any object with the boom.
- Never attempt to use the machine as a crane. Do not tie-off machine to any adjacent structure.
- Do not operate the machine when wind conditions exceed 28 mph (12.5 m/s). Refer to Table 1-2, Beaufort Scale (For Reference Only).
- Do not increase the surface area of the platform or the load. Increase of the area exposed to the wind will decrease stability.
- Do not increase the platform size with unauthorized deck extensions or attachments.

- If boom assembly or platform is in a position that one or more wheels are off the ground, all persons must be removed before attempting to stabilize the machine. Use cranes, forklift trucks, or other appropriate equipment to stabilize machine.

### Crushing and Collision Hazards

- Approved head gear must be worn by all operating and ground personnel.
- Check work area for clearances overhead, on sides, and bottom of platform when lifting or lowering platform, and driving.

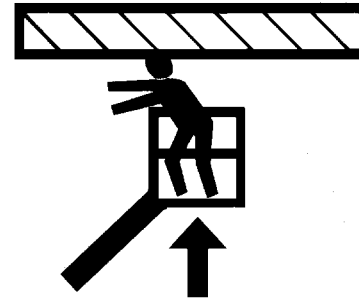

- During operation, keep all body parts inside platform railing.

## **SECTION 1 - SAFETY PRECAUTIONS**

---

- Use the boom functions, not the drive function, to position the platform close to obstacles.
- Always post a lookout when driving in areas where vision is obstructed.
- Keep non-operating personnel at least 6 ft. (1.8m) away from machine during all driving and swing operations.
- Limit travel speed according to conditions of ground surface, congestion, visibility, slope, location of personnel, and other factors which may cause collision or injury to personnel.
- Be aware of stopping distances in all drive speeds. When driving in high speed, switch to low speed before stopping. Travel grades in low speed only.
- Do not use high speed drive in restricted or close quarters or when driving in reverse.
- Exercise extreme caution at all times to prevent obstacles from striking or interfering with operating controls and persons in the platform.
- Be sure that operators of other overhead and floor level machines are aware of the aerial work platform's presence. Disconnect power to overhead cranes.
- Warn personnel not to work, stand, or walk under a raised boom or platform. Position barricades on floor if necessary.

### **1.4 TOWING, LIFTING, AND HAULING**

- Never allow personnel in platform while towing, lifting, or hauling.
- This machine should not be towed, except in the event of emergency, malfunction, power failure, or loading/unloading. Refer to the Emergency Procedures section of this manual for emergency towing procedures.
- Ensure boom is in the stowed position and the turntable locked prior to towing, lifting or hauling. The platform must be completely empty of tools.
- When lifting machine, lift only at designated areas of the machine. Lift the unit with equipment of adequate capacity.
- Refer to the Machine Operation section of this manual for lifting information.

### 1.5 ADDITIONAL HAZARDS / SAFETY

- Do not use machine as a ground for welding.
- When performing welding or metal cutting operations, precautions must be taken to protect the chassis from direct exposure to weld and metal cutting spatter.
- Do not refuel the machine with the engine running.
- Battery fluid is highly corrosive. Avoid contact with skin and clothing at all times.
- Charge batteries only in a well ventilated area.

## SECTION 1 - SAFETY PRECAUTIONS

---

### **NOTICE**

**DO NOT OPERATE THE MACHINE WHEN WIND CONDITIONS EXCEED 28 MPH (12.5 M/S).**

**Table 1-2. Beaufort Scale (For Reference Only)**

Beaufort Number	Wind Speed		Description	Land Conditions
	mph	m/s		
0	0	0-0.2	Calm	Calm. Smoke rises vertically
1	1-3	0.3-1.5	Light air	Wind motion visible in smoke
2	4-7	1.6-3.3	Light breeze	Wind felt on exposed skin. Leaves rustle
3	8-12	3.4-5.4	Gentle breeze	Leaves and smaller twigs in constant motion
4	13-18	5.5-7.9	Moderate breeze	Dust and loose paper raised. Small branches begin to move.
5	19-24	8.0-10.7	Fresh breeze	Smaller trees sway.
6	25-31	10.8-13.8	Strong breeze	Large branches in motion. Whistling heard in overhead wires. Umbrella use becomes difficult.
7	32-38	13.9-17.1	Near Gale/Moderate Gale	Whole trees in motion. Effort needed to walk against the wind.
8	39-46	17.2-20.7	Fresh Gale	Twigs broken from trees. Cars veer on road.
9	47-54	20.8-24.4	Strong Gale	Light structure damage.

## **SECTION 2. USER RESPONSIBILITIES, MACHINE PREPARATION, AND INSPECTION**

### **2.1 PERSONNEL TRAINING**

The aerial platform is a personnel handling device; so it is necessary that it be operated and maintained only by trained personnel.

Persons under the influence of drugs or alcohol or who are subject to seizures, dizziness or loss of physical control must not operate this machine.

#### **Operator Training**

Operator training must cover:

1. Use and limitations of the controls in the platform and at the ground, emergency controls and safety systems.
2. Control labels, instructions, and warnings on the machine.
3. Rules of the employer and government regulations.
4. Use of approved fall protection device.
5. Enough knowledge of the mechanical operation of the machine to recognize a malfunction or potential malfunction.

6. The safest means to operate the machine where overhead obstructions, other moving equipment, and obstacles, depressions, holes, dropoffs.
7. Means to avoid the hazards of unprotected electrical conductors.
8. Specific job requirements or machine application.

#### **Training Supervision**

Training must be done under the supervision of a qualified person in an open area free of obstructions until the trainee has developed the ability to safely control and operate the machine.

#### **Operator Responsibility**

The operator must be instructed that he/she has the responsibility and authority to shut down the machine in case of a malfunction or other unsafe condition of either the machine or the job site.

## **2.2 PREPARATION, INSPECTION, AND MAINTENANCE**

The following table covers the periodic machine inspections and maintenance recommended by JLG Industries, Inc. Consult local regulations for further requirements for aerial work platforms. The frequency of inspections and maintenance must be increased as necessary when the machine is used in a harsh or hostile environment, if the machine is used with increased frequency, or if the machine is used in a severe manner.

### **NOTICE**

**JLG INDUSTRIES, INC. RECOGNIZES A FACTORY-TRAINED SERVICE TECHNICIAN AS A PERSON WHO HAS SUCCESSFULLY COMPLETED THE JLG SERVICE TRAINING SCHOOL FOR THE SPECIFIC JLG PRODUCT MODEL.**

## SECTION 2 - USER RESPONSIBILITIES, MACHINE PREPARATION, AND INSPECTION

**Table 2-1. Inspection and Maintenance Table**

Type	Frequency	Primary Responsibility	Service Qualification	Reference
Pre-Start Inspection	Before using each day; or whenever there's an Operator change.	User or Operator	User or Operator	Operator and Safety Manual
Pre-Delivery Inspection (See Note)	Before each sale, lease, or rental delivery.	Owner, Dealer, or User	Qualified JLG Mechanic	Service and Maintenance Manual and applicable JLG inspection form
Frequent Inspection (See Note)	In service for 3 months or 150 hours, whichever comes first; or Out of service for a period of more than 3 months; or Purchased used.	Owner, Dealer, or User	Qualified JLG Mechanic	Service and Maintenance Manual and applicable JLG inspection form
Annual Machine Inspection (See Note)	Annually, no later than 13 months from the date of prior inspection.	Owner, Dealer, or User	Factory-Trained Service Technician (Recommended)	Service and Maintenance Manual and applicable JLG inspection form
Preventative Maintenance	At intervals as specified in the Service and Maintenance Manual.	Owner, Dealer, or User	Qualified JLG Mechanic	Service and Maintenance Manual
<b>NOTE:</b> Inspection forms are available from JLG. Use the Service and Maintenance Manual to perform inspections.				

## SECTION 2 - USER RESPONSIBILITIES, MACHINE PREPARATION, AND INSPECTION

### Pre-Start Inspection

The Pre-Start Inspection should include each of the following:

1. **Cleanliness** – Check all surfaces for leakage (oil, fuel, or battery fluid) or foreign objects. Report any leakage to the proper maintenance personnel.
2. **Structure** - Inspect the machine structure for dents, damage, weld or parent metal cracks or other discrepancies.

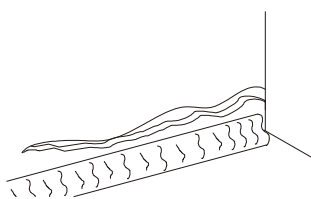

Parent Metal Crack

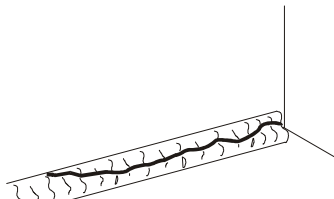

Weld Crack

3. **Decals and Placards** – Check all for cleanliness and legibility. Make sure none of the decals and placards are missing. Make sure all illegible decals and placards are cleaned or replaced.
4. **Operators and Safety Manuals** – Make sure a copy of the Operator and Safety Manual, EMI Safety Manual (Domestic only), and ANSI Manual of Responsibilities

(Domestic only) is enclosed in the weather resistant storage container.

5. **“Walk-Around” Inspection** – Refer to Figure 2-4. thru Figure 2-6.
6. **Battery** – Charge as required.
7. **Fuel** (Combustion Engine Powered Machines) – Add the proper fuel as necessary.
8. **Hydraulic Oil** – Check the hydraulic oil level. Ensure hydraulic oil is added as required.
9. **Function Check** – Once the “Walk-Around” Inspection is complete, perform a functional check of all systems in an area free of overhead and ground level obstructions. Refer to Section 4 for more specific instructions.

### **⚠ WARNING**

**IF THE MACHINE DOES NOT OPERATE PROPERLY, TURN OFF THE MACHINE IMMEDIATELY! REPORT THE PROBLEM TO THE PROPER MAINTENANCE PERSONNEL. DO NOT OPERATE THE MACHINE UNTIL IT IS DECLARED SAFE FOR OPERATION.**



## SECTION 2 - USER RESPONSIBILITIES, MACHINE PREPARATION, AND INSPECTION

### Function Check

Perform the Function Check as follows:

1. From the ground control panel with no load in the platform:
  - a. Check that all guards protecting the switches or locks are in place;
  - b. Operate all functions and check boom limit switches; drive speed should switch to creep mode if lower boom is elevated or main boom is above horizontal.
  - c. Check auxiliary power (or manual descent);
  - d. Ensure that all machine functions are disabled when the Emergency Stop Button is activated.
  
2. From the platform control console:
  - a. Ensure that the control console is firmly secured in the proper location;
  - b. Check that all guards protecting the switches or locks are in place;
  - c. Operate all functions and check all limiting and cut-out switches;

Cutout	Description	Market
Tilt & High Drive	5 degree-reduces the maximum speed of all boom functions to creep when tilted and above elevation. Reduces drive speed to creep when tilted. (See Figure 2-1.)	ANSI & Japan
	3 degree-reduces the maximum speed of all boom functions to creep when tilted and above elevation. Reduces drive speed to creep when tilted. (See Figure 2-1.)	CE & Australia
Drive	Battery Charger Cutout-cuts out drive when the battery charger is plugged in.	All
	Battery Charger Cutout and Simultaneous Drive and Boom Functions disabled above elevation. (See Figure 2-1.)	CE & Australia

- d. Ensure that all machine functions are disabled when the Emergency Stop Button is pushed in.
  
3. With the platform in the transport (stowed) position:
  - a. Drive the machine on a grade, not to exceed the rated gradeability, and stop to ensure the brakes hold;
  - b. Check the tilt indicator light to ensure proper operation.

## SECTION 2 - USER RESPONSIBILITIES, MACHINE PREPARATION, AND INSPECTION

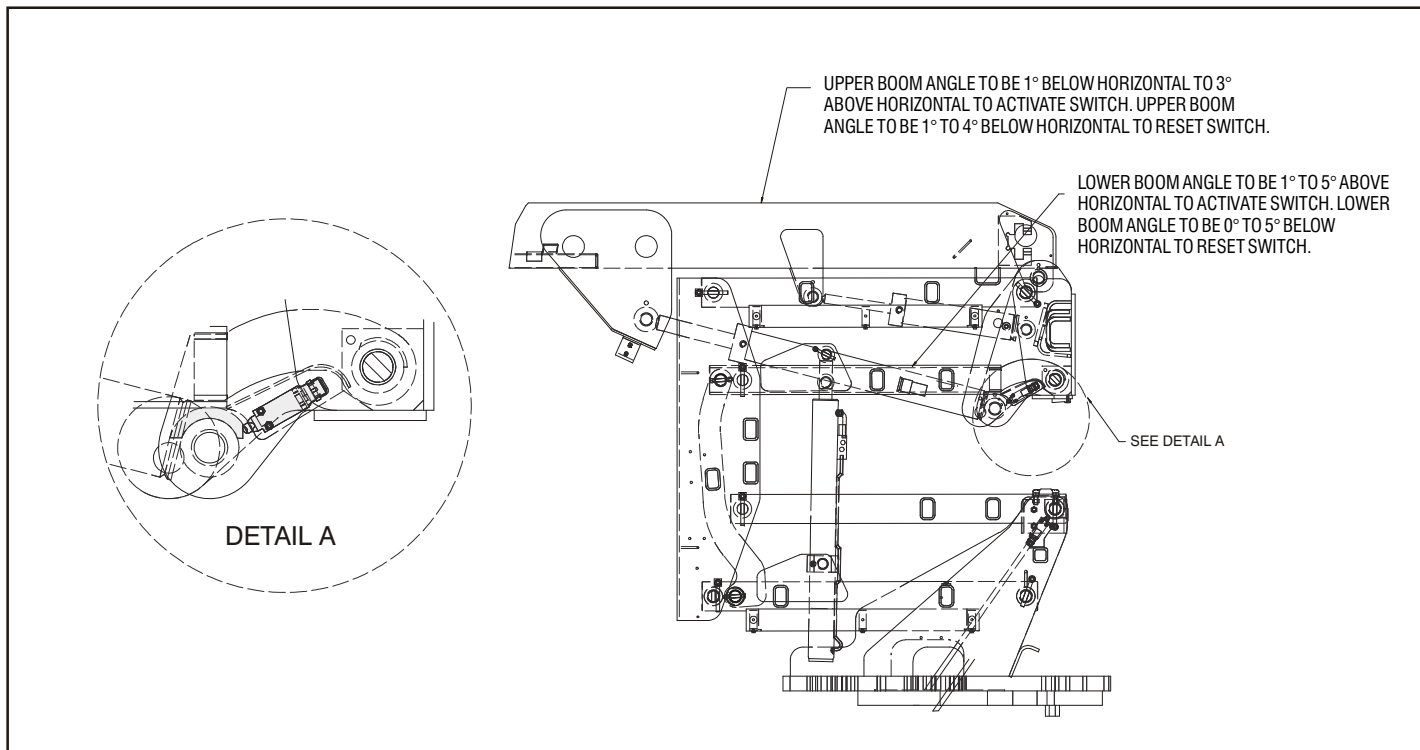
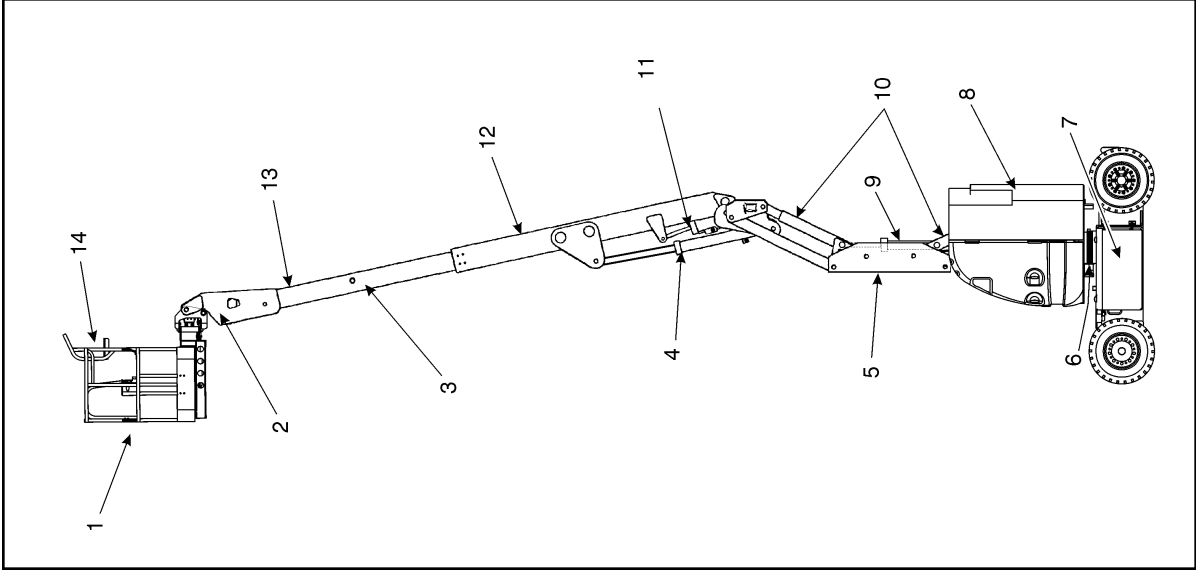

Figure 2-1. Boom Cutout Switches

**SECTION 2 - USER RESPONSIBILITIES, MACHINE PREPARATION, AND INSPECTION**



- 1. Platform
- 2. Slave Cylinder (Inside)
- 3. Telescope Cylinder (Inside)
- 4. Main Boom Lift Cylinder
- 5. Upright
- 6. Swing Bearing
- 7. Battery Box
- 8. Turntable
- 9. Lower Lift Cylinder
- 10. Lower Arms
- 11. Master Cylinder
- 12. Base Boom
- 13. Fly Boom
- 14. Platform Control Box

**Figure 2-2. Basic Nomenclature - E300A**

## SECTION 2 - USER RESPONSIBILITIES, MACHINE PREPARATION, AND INSPECTION

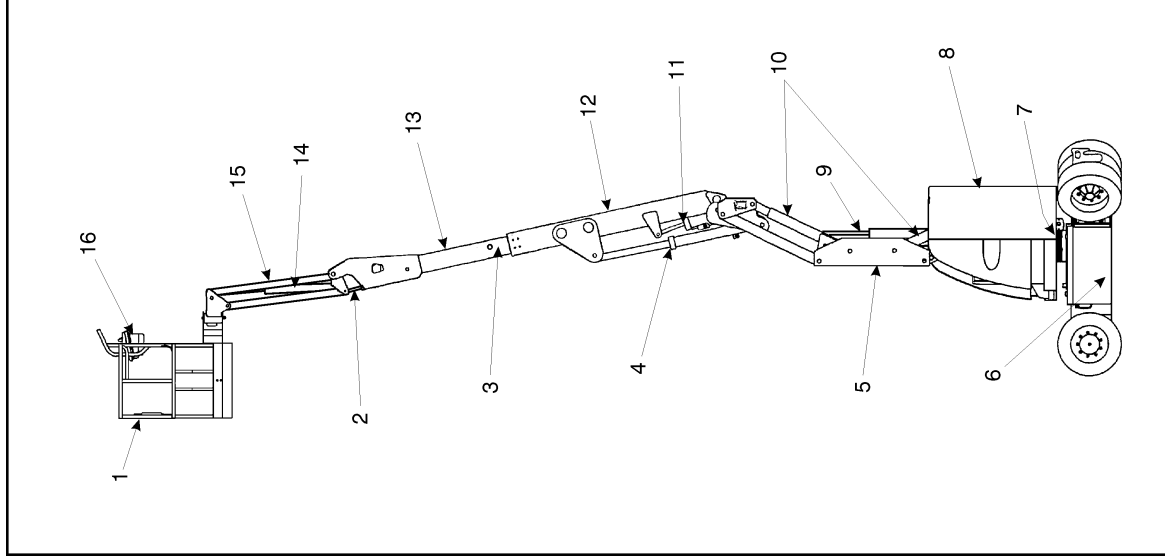

- |                                |                        |                          |
|--------------------------------|------------------------|--------------------------|
| 1. Platform                    | 7. Swing Bearing       | 12. Base Boom            |
| 2. Slave Cylinder (Inside)     | 8. Turntable           | 13. Fly Boom             |
| 3. Telescope Cylinder (Inside) | 9. Lower Lift Cylinder | 14. Jib Cylinder         |
| 4. Main Boom Lift Cylinder     | 10. Lower Arms         | 15. Jib                  |
| 5. Upright                     | 11. Master Cylinder    | 16. Platform Control Box |
| 6. Battery Box                 |                        |                          |

**Figure 2-3. Basic Nomenclature - E300AJ & E300AJP**

## SECTION 2 - USER RESPONSIBILITIES, MACHINE PREPARATION, AND INSPECTION

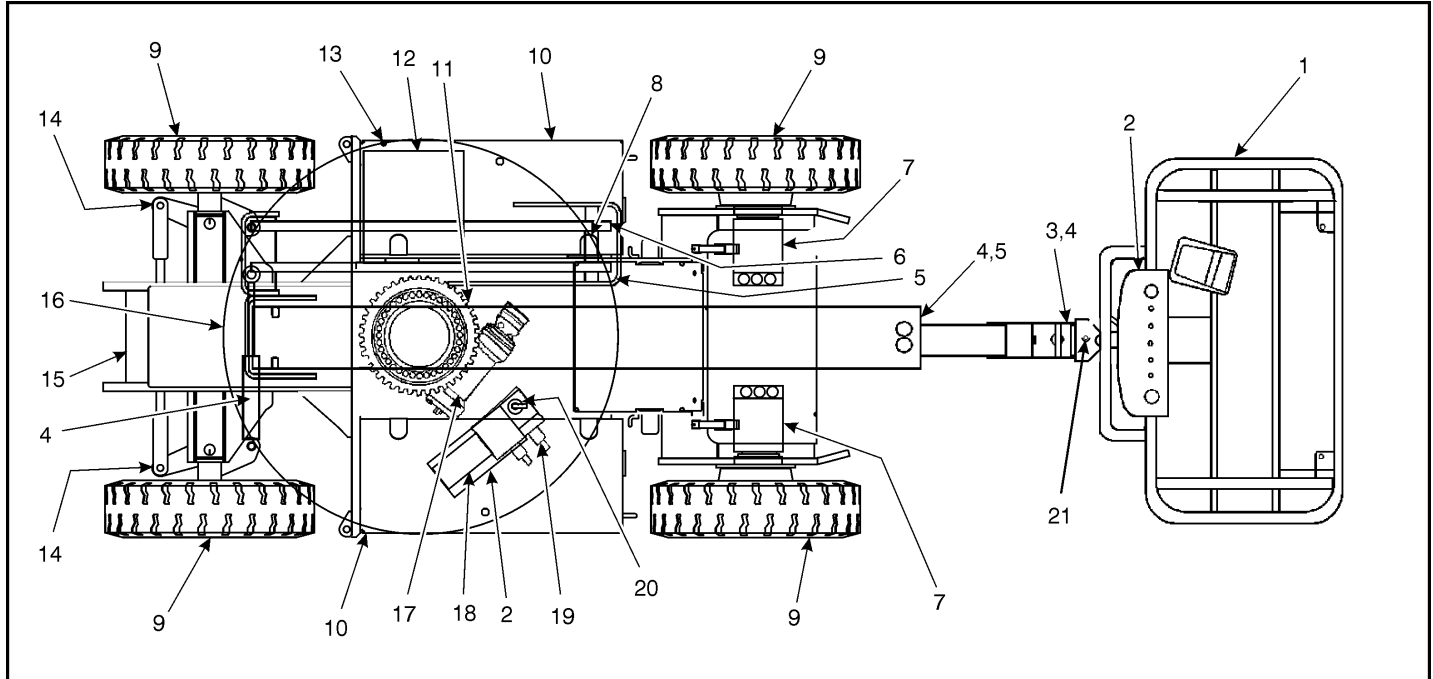

Figure 2-4. Daily Walk - Around Inspection (Sheet 1 of 3)

## SECTION 2 - USER RESPONSIBILITIES, MACHINE PREPARATION, AND INSPECTION

---

### GENERAL

Begin the "Walk-Around Inspection" at Item 1, as noted on the diagram. Continue to the right (counterclockwise viewed from top) checking each item in sequence for the conditions listed in the following checklist.

#### **WARNING**

**TO AVOID POSSIBLE INJURY, BE SURE MACHINE POWER IS OFF.**

**DO NOT OPERATE MACHINE UNTIL ALL MALFUNCTIONS HAVE BEEN CORRECTED.**

**INSPECTION NOTE:** *On all components, make sure there are no loose or missing parts, that they are securely fastened, and no visible damage, leaks or excessive wear exists in addition to any other criteria mentioned.*

- 1. Platform Assembly and Gate** - Lockbolts in place. Footswitch works properly, not modified, disabled or blocked. Latch, stop, and hinges in working condition.
- 2. Platform & Ground Control Consoles** - Switches and levers return to neutral, decals/placards secure and legible, control markings legible.
- 3. Fly Boom Nose and Platform Support** - Ensure fly boom nose and platform support are free of debris, obstructions, etc.
- 4. All Hydraulic Cylinders** - No visible damage; pivot pins and hydraulic hoses undamaged, not leaking.
- 5. Slave Cylinder** - No visible damage; pivot pins secure; hydraulic hoses undamaged, not leaking.
- 6. Boom Sections/Uprights/Turntable** - See Inspection Note.
- 7. Limit Switches** - Switches operable; See Inspection Note.
- 8. Drive Motor, Brake and Hub** - See Inspection Note.
- 9. Hydraulic Oil Filter Housing** - See Inspection Note.
- 10. Battery Compartment** - Batteries have proper electrolyte level; cables tight; See Inspection Note.
- 11. Turntable Bearing** - See Inspection Note; evidence of proper lubrication. No loose bolts or looseness between bearing and structure.

**Figure 2-5. Daily Walk-Around Inspection - Sheet 2 of 3**

## **SECTION 2 - USER RESPONSIBILITIES, MACHINE PREPARATION, AND INSPECTION**

---

12. **Hydraulic Pump and Reservoir** - See Inspection Note. Recommended hydraulic fluid level on sight gage (system shut down, boom in stowed position). Breather cap secure and working.
13. **Cowling and Latches** - All cowling, doors and latches in working condition; See Inspection Note.
14. **Tie Rod Ends and Steering Spindles** - See Inspection Note. Tie rod end stubs locked.
15. **Frame** - See Inspection Note. No evidence of cables dragging under the machine.
16. **Counterweight** - See Inspection Note.
17. **Swing Motor and Worm Gear** - See Inspection Note; evidence of proper lubrication.
18. **Battery Charger** - See Inspection Note.
19. **Control Valve** - See Inspection Note.
20. **Manual Descent Valve** - See Inspection Note.
21. **Jib (E300 AJ only)** - See Inspection Note.

**Figure 2-6. Daily Walk-Around Inspection - Sheet 3 of 3**

## SECTION 2 - USER RESPONSIBILITIES, MACHINE PREPARATION, AND INSPECTION

---



**NOTES:**

---

---

---

---

---

---

---

---

---

---

---

---

---

---

---

---

---

---

---

---

---

---

---

---

---

---

---

---

---

---

---

---

---

---

---

---

---

---

---

---

---

---

---

---

---

---

---

---

---

---



## SECTION 3. MACHINE CONTROLS AND INDICATORS

### 3.1 GENERAL

#### **NOTICE**

**THE MANUFACTURER HAS NO DIRECT CONTROL OVER MACHINE APPLICATION AND OPERATION. THE USER AND OPERATOR ARE RESPONSIBLE FOR CONFORMING WITH GOOD SAFETY PRACTICES.**

This section provides the necessary information needed to understand control functions.

### 3.2 CONTROLS AND INDICATORS

**NOTE:** *This machines is equipped with control panels that use symbols to indicate control functions. On ANSI machines, refer to decal located on the control box guard in front of the control box or by the ground controls for these symbols and the corresponding functions.*

### Ground Control Station

*See Figure 3-1., Figure 3-2., and Figure 3-3.*

**NOTE:** *When machine is shut down the Platform/Ground Select switch and Emergency Stop must be positioned to OFF.*

**NOTE:** *When Power/Emergency Stop Switch is in the on position and motor is not running, an alarm will sound, indicating power is on.*

**NOTE:** *If equipped, the Function Enable switch must be held down in order to operate Boom Telescope, Lower Lift, Swing, Main Lift, Jib Lift, Platform Level Override, and Platform Rotate functions.*

#### 1. Battery Status

Three LED lights indicate charge status of battery. **Green;** indicates 100% charged. **Yellow;** indicates charger on. **Red;** indicates abnormal battery condition.

#### 2. Jib Swing (E300 AJP only)

A jib swing joystick controls raising and lowering and swinging left and right of platform.

## SECTION 3 - MACHINE CONTROLS AND INDICATORS

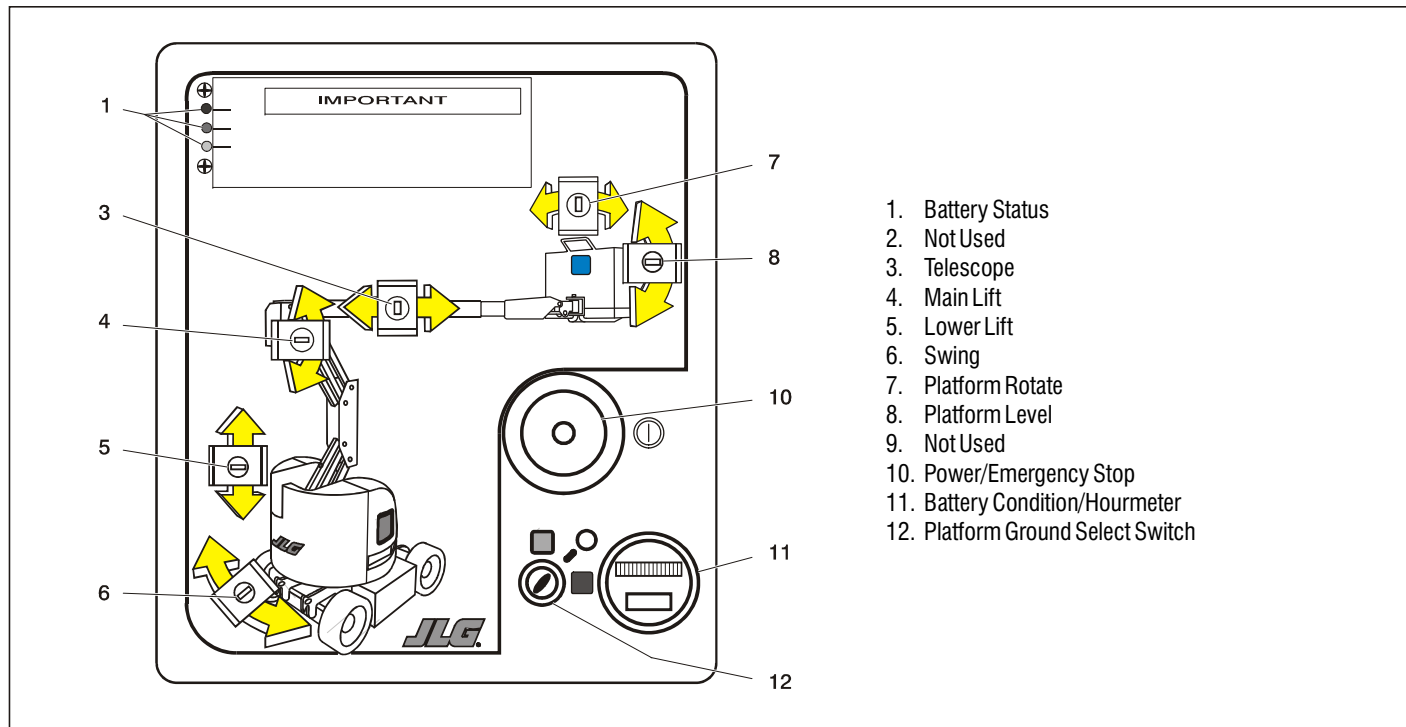
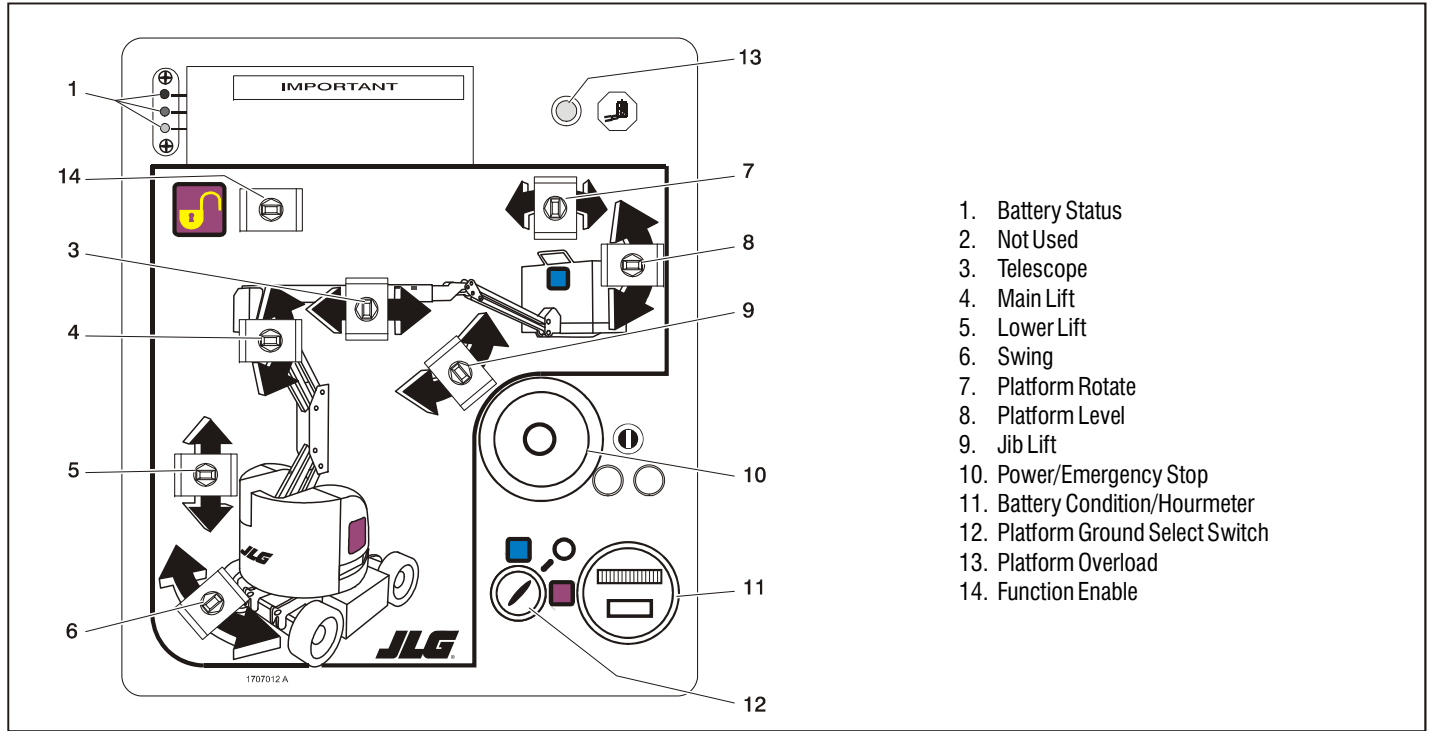

Figure 3-1. Ground Control Station - 300A



1. Battery Status
2. Not Used
3. Telescope
4. Main Lift
5. Lower Lift
6. Swing
7. Platform Rotate
8. Platform Level
9. Jib Lift
10. Power/Emergency Stop
11. Battery Condition/Hourmeter
12. Platform Ground Select Switch
13. Platform Overload
14. Function Enable

**Figure 3-2. Ground Control Station - 300AJ**

## SECTION 3 - MACHINE CONTROLS AND INDICATORS

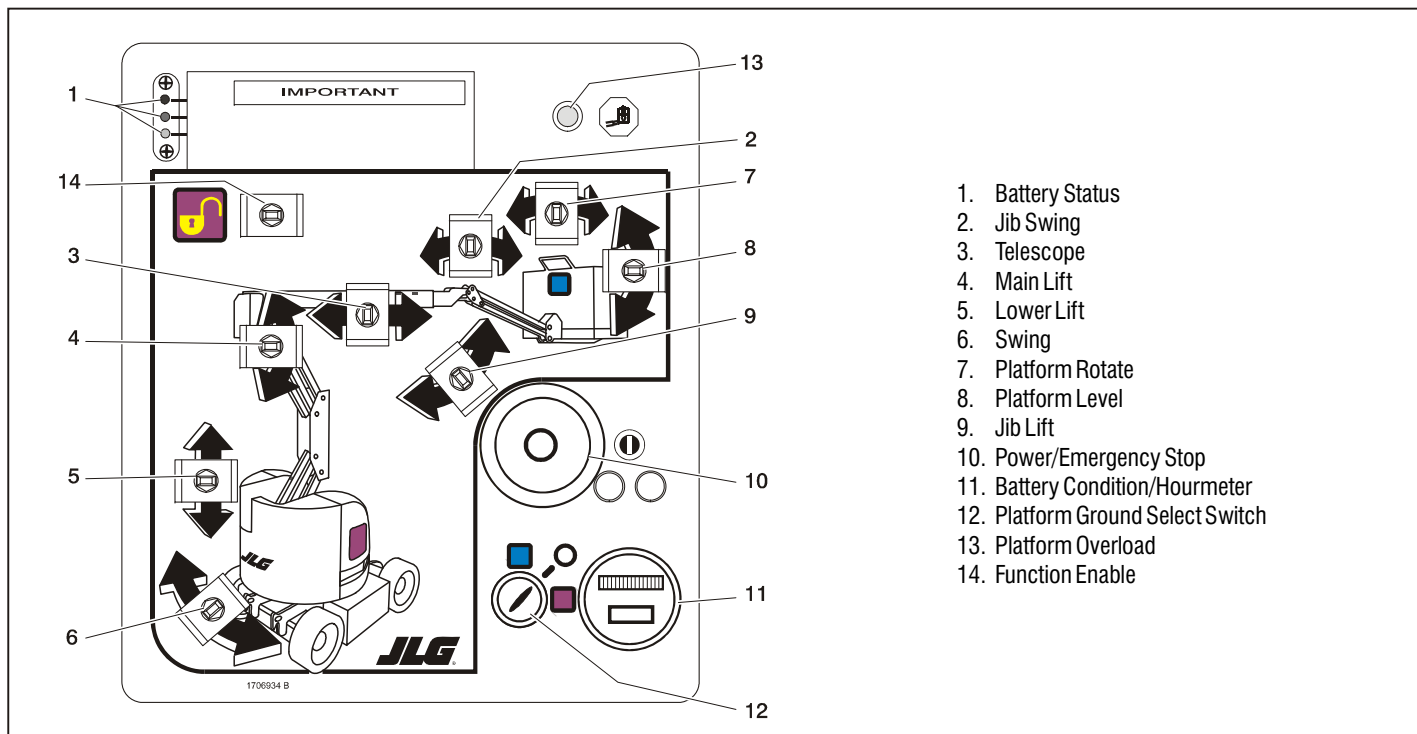

Figure 3-3. Ground Control Station - 300AJP

## SECTION 3 - MACHINE CONTROLS AND INDICATORS

---

### 3. Telescope

Provides extension and retraction of the main boom.

**NOTE:** *Main Lift, Swing, Platform Level, Main Telescope, Lower Lift and Platform Rotator control switches are spring-loaded and will automatically return to neutral (off) when released.*

### 4. Main Lift

Provides raising/lowering of the main boom when positioning up or down.

### 5. Lower Lift

Provides raising and lowering of the upright and lower arms.

### 6. Swing Control

Provides 360 degrees non-continuous turntable rotation. To activate SWING, position switch to LEFT or RIGHT.

### 7. Platform Rotate

Permits rotation of the platform when positioned to the right or left.



**ONLY USE THE PLATFORM LEVELING OVERRIDE FUNCTION FOR SLIGHT LEVELING OF THE PLATFORM. INCORRECT USE COULD CAUSE THE LOAD/OCCUPANTS TO SHIFT OR FALL. FAILURE TO DO SO COULD RESULT IN DEATH OR SERIOUS INJURY.**

### 8. Platform leveling Override

Allows the operator to compensate for any difference in the automatic self leveling system by positioning the control switch up or down. The switch is used to adjust the platform level in situations such as ascending/descending a grade.

### 9. Jib (if equipped)

Provides for raising or lowering of the jib by positioning up/down.

## SECTION 3 - MACHINE CONTROLS AND INDICATORS

---

### CAUTION

**WHEN THE MACHINE IS SHUT DOWN THE MASTER/EMERGENCY STOP SWITCH MUST BE POSITIONED TO THE OFF POSITION TO PREVENT DRAINING THE BATTERIES.**

#### 10. Power/Emergency Stop Switch.

A two-position red mushroom shaped switch furnishes power to PLATFORM/GROUND SELECT switch when pulled out (on). When pushed in (off), power is shut off to the PLATFORM/GROUND SELECT switch.

#### 11. Battery Indicator and Hourmeter

The battery indicator registers the present charge of the batteries. The hourmeter registers the amount of machine operating time, up to 9,999.9 hours, and cannot be reset.

#### 12. Control Station Selector

Supplies power to the platform control console when positioned to the PLATFORM. With the switch in GROUND position, power is shut off to the platform control console, and only the controls on the ground control panel are operable.

**NOTE:** *When the Platform/Ground Select Switch is in the center position, power is shut off to the controls at both operating stations. Remove the key to prevent the controls from being actuated. The key is removable in the platform position on CE machines. The key must be available to ground personnel in the event of an emergency.*

#### 13. Platform Overload (If equipped)

Indicates the platform has been overloaded.

#### 14. Function Enable

If equipped, the enable switch must be held "DOWN" to enable all boom controls when the engine is running.

### Platform Control Station

See Figure 3-4.

#### 1. Posi-Track

When one wheel is slipping and the machine is not descending a grade, automatic traction control will provide added torque to both wheels. While this function is automatic, it may also be manually engaged by moving the toggle switch to the forward position. Positrac will be engaged for approximately 20 seconds.

### **⚠ WARNING**

**ONLY USE THE PLATFORM LEVELING OVERRIDE FUNCTION FOR SLIGHT LEVELING OF THE PLATFORM. INCORRECT USE COULD CAUSE THE LOAD/OCCUPANTS TO SHIFT OR FALL. FAILURE TO DO SO COULD RESULT IN DEATH OR SERIOUS INJURY.**

#### 2. Platform Leveling Override

The PLATFORM LEVEL control switch allows the operator to adjust the level of the platform by positioning the switch to UP or DOWN. The switch is used to adjust the platform level in situations such as ascending/descending a grade.

#### 3. Horn

A push-type HORN switch supplies electrical power to an audible warning device when pressed.

#### 4. Power/Emergency Stop

A two-position red mushroom shaped switch furnishes power to PLATFORM Controls when pulled out (on). When pushed in (off), power is shut off to the platform functions.

#### 5. Lights (If Equipped)

This switch operates control console panel lights and head lights if the machine is so equipped.

## SECTION 3 - MACHINE CONTROLS AND INDICATORS

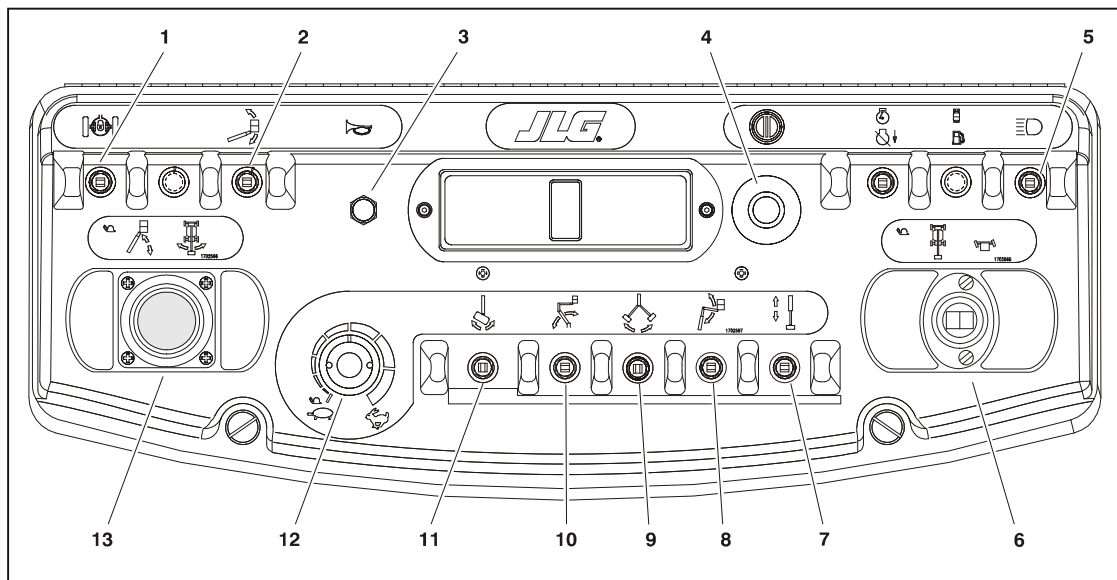

- |                               |                |                     |                     |
|-------------------------------|----------------|---------------------|---------------------|
| 1. Posi-Track                 | 5. Lights      | 8. Jib              | 11. Platform Rotate |
| 2. Platform Leveling Override | 6. Drive/Steer | 9. Jib Swing        | 12. Function Speed  |
| 3. Horn                       | 7. Telescope   | 10. Lower Boom Lift | 13. Main Lift/Swing |
| 4. Power/Emergency Stop       |                |                     |                     |

**Figure 3-4. Platform Control Console**



## SECTION 3 - MACHINE CONTROLS AND INDICATORS

---

**NOTE:** *Main Lift, Swing, and Drive control levers are spring loaded and will automatically return to neutral (off) position when released.*

### 6. Drive/Steer

Push forward to drive forward, pull back to drive in reverse. Steering is accomplished via a thumb-activated rocker switch on the end of the steer handle.

**NOTE:** *When boom is positioned above horizontal and Posi-Track or Function speed are positioned to high, high function speeds are automatically cut out and the machine continues to operate at a lower speed.*

### 7. Telescope

Provides extension and retraction of the main boom.

### 8. Jib (If equipped)

Provides for raising or lowering of the jib by positioning up/down.

### 9. Jib Swing (If equipped)

Provides jib swing right or left.

### 10. Lower Lift

Provides for raising and lowering of Upright when positioned to UP or DOWN.

### 11. Platform Rotate

Permits rotation of the platform when positioned to the right or left.

### 12. Function Speed Control

Adjusts speed of Boom and Swing Functions. Rotate CCW for slower speed and CW for faster speed. To adjust Drive, Swing, and Main Lift to creep, turn knob fully CCW until it clicks.

### 13. Main Lift/Swing Controller

Provides main lift and swing. Push forward to lift up, pull backward to boom down. Move right to swing right, move left to swing left. Moving the joystick activates switches to provide the functions selected. Proportional control of these functions can be attained by using the Function Speed knob.

## SECTION 3 - MACHINE CONTROLS AND INDICATORS

**Table 3-1.Simultaneous Functions**

If This Function is Selected:	These Functions Will Also Work at the Same Time:				
Drive and Steer		Swing*	Lower Lift**	Main Lift**	Telescope
Swing	Drive and Steer		Lower Lift**	Main Lift**	Telescope
Lower Lift	Drive and Steer	Swing*		No	Telescope
Main Lift	Drive and Steer	Swing*	No		Telescope
Telescope	Drive and Steer	Swing*	Lower Lift**	Main Lift**	
Jib Articulate	Drive and Steer	Swing*	Lower Lift**	Main Lift**	Telescope
Jib Swing	Drive and Steer	No	No	No	No
Platform Rotate	Drive and Steer	No	No	No	No

**NOTE:** Boom functions are slower when selected with another function than when operated individually, due to sharing oil.

\* The functions may move slow (or not at all) if the first function selected (Lower Lift or Swing) is being operated at full speed, due to sharing of oil.

\*\* Lower Lift and Upper Lift will not function simultaneously. Upper Lift will always prevail.

**Platform Control Indicator Panel**

**NOTE:** *The platform control indicator panel uses different shaped symbols to alert the operator to different types of operational situations that could arise. The meaning of those symbols are explained below.*



*Indicates a potentially hazardous situation, which if not corrected, could result in serious injury or death. This indicator will be red.*



*Indicates an abnormal operating condition, which if not corrected, may result in machine interruption or damage. This indicator will be yellow.*



*Indicates important information regarding the operating condition, i.e. procedures essential for safe operation. This indicator will be green with the exception of the capacity indicator which will be green or yellow depending upon platform position.*

**1. Tilt Alarm Warning Light and Alarm**

Tilt Angle	Market
3°	CE & Australia
5°	ANSI & Japan

This orange illuminator indicates that the chassis is on a slope. An alarm will also sound when the chassis is on a slope and the boom is above horizontal. If lit when boom is raised or extended, retract and lower to below horizontal then reposition machine so that it is level before continuing operation. If the boom is above horizontal and the machine is on a slope, the tilt alarm warning light will illuminate and an alarm will sound and CREEP is automatically activated.



**IF TILT WARNING LIGHT IS ILLUMINATED WHEN BOOM IS RAISED OR EXTENDED, RETRACT AND LOWER TO BELOW HORIZONTAL THEN REPOSITION MACHINE SO THAT IT IS LEVEL BEFORE EXTENDING BOOM OR RAISING BOOM ABOVE HORIZONTAL.**

## SECTION 3 - MACHINE CONTROLS AND INDICATORS

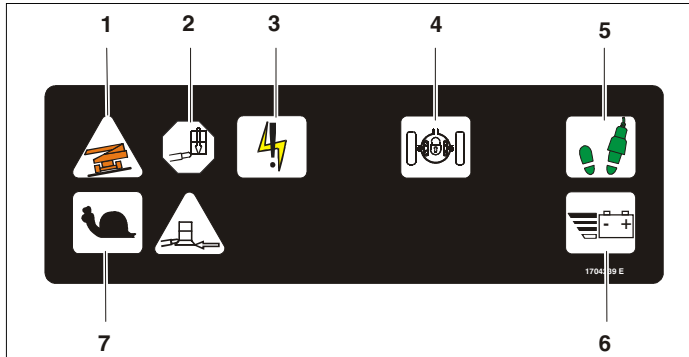

- |                      |                |
|----------------------|----------------|
| 1. Tilt              | 5. Enable      |
| 2. Platform Overload | 6. Low Battery |
| 3. System Distress   | 7. Creep       |
| 4. Posi-Track        |                |

**Figure 3-5. Platform Control Indicator Panel**

**2. Platform Overload (If equipped)**

Indicates the platform has been overloaded.

**3. System Distress Indicator**

The system distress indicator lights to signify an electrical system fault.

The four likely causes of a system fault are:

- The seven second enable time has been allowed to lapse or a function was selected before depressing the footswitch. The system reads this condition as a fault, just as it would if the footswitch were jammed in the depressed position or a function switch were stuck in the on position. Re-depress the footswitch to power the controls and extinguish the light.
- The maximum power limit has been reached and the machine is not moving. This could happen when the machine is stuck or when attempting to travel over rough terrain or on steep grades which exceed the rated gradeability of the machine. This condition is comparable to stalling the engine by asking it to provide more power than it was designed to do.
- The batteries are nearly depleted, and should be charged very soon to prevent having the machine stop at an inconvenient place.
- There is some other fault in one of the circuits. If so determine the cause by counting the flash code, a number of flashes followed by a pause followed by another number of flashes, and refer to the service manual.

### 4. Posi-Track Indicator

This indicator lights to show that posi-traction is operating.

### 5. Enable Indicator/Footswitch

To operate any function, the footswitch must be depressed and the function selected within seven seconds. The enable indicator shows that the controls are enabled. If a function is not selected within seven seconds, or if a seven second lapse between ending one function and beginning the next function, the enable light will go out and the footswitch must be released and depressed again to enable the controls.

Releasing the footswitch removes power from all controls and applies the drive brakes.

### **WARNING**

**TO AVOID SERIOUS INJURY, DO NOT REMOVE, MODIFY OR DISABLE THE FOOTSWITCH BY BLOCKING OR ANY OTHER MEANS.**

### **WARNING**

**FOOTSWITCH MUST BE ADJUSTED IF FUNCTIONS ACTIVATE WHEN SWITCH ONLY OPERATES WITHIN LAST 1/4" OF TRAVEL, TOP OR BOTTOM.**

### 6. Low Battery Indicator

Indicates the batteries are low and need to be charged.

### 7. Creep Speed Indicator

When the Function Speed Control is turned to the creep position, the indicator acts as a reminder that all functions are set to the slowest speed.

### SECTION 3 - MACHINE CONTROLS AND INDICATORS

---



**NOTES:**

## **SECTION 4. MACHINE OPERATION**

### **4.1 DESCRIPTION**

This machine is a self-propelled hydraulic lift equipped with a work platform on the end of an elevating, articulating and rotating boom.

The primary operator control station is in the platform. From this control station, the operator can drive and steer the machine in both forward and reverse directions. The operator can raise or lower the boom or swing the boom to the left or right. Standard boom swing is 360 degree non-continuous left and right of the stowed position. The machine has a Ground Control Station which will override the Platform Control Station. Ground Controls operate Boom Lift and Swing, and are to be used in an emergency to lower the platform to the ground should the operator in the platform be unable to do so. The Ground Control is also to be used in Pre-Start Inspection.

### **4.2 OPERATING CHARACTERISTICS AND LIMITATIONS**

#### **Capacities**

Raising boom above horizontal with or without any load in platform, is based on the following criteria:

1. Machine is positioned on a smooth, firm and level surface.
2. Load is within manufacturers rated design capacity.
3. All machine systems are functioning properly.
4. Machine is as originally equipped from JLG.

### Stability

Machine stability is based on two (2) conditions which are called FORWARD stability and BACKWARD stability. The machine's position of least FORWARD stability is shown in Figure 4-1. and its position of least BACKWARD stability is shown in Figure 4-2.

#### **WARNING**

**TO AVOID FORWARD OR BACKWARD UPSET, DO NOT OVERLOAD MACHINE, OR OPERATE ON OUT-OF-LEVEL SURFACE.**

### 4.3 MOTOR OPERATION

#### Power/Emergency Stop

This red, mushroom-shaped switch provides battery power to the Platform/Ground Select switch, when pulled out (on), for all machine functions. The switch should be pushed in (off) when recharging the batteries or parking the machine overnight.

#### Platform/Ground Select Switch

The Platform/Ground Select switch functions to direct battery power to the desired control station when the POWER/EMERGENCY STOP switch is pulled out (on). With the switch in the GROUND position, battery power is supplied to the ground control station. When the switch is in the PLATFORM position, battery power is supplied to the platform control station.

The key is removable in the platform position on CE machines. The key must be available to ground personnel in the event of an emergency.



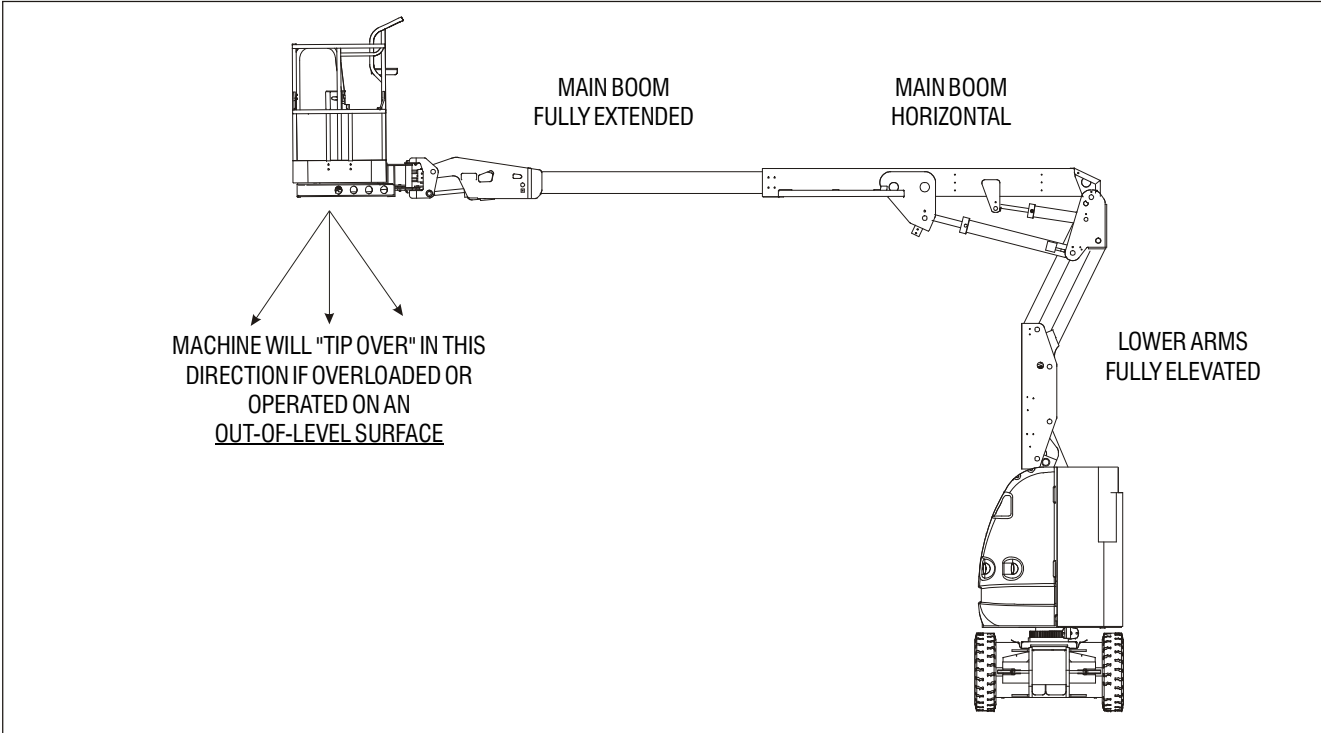

**Figure 4-1. Position Of Least Forward Stability**

## SECTION 4 - MACHINE OPERATION

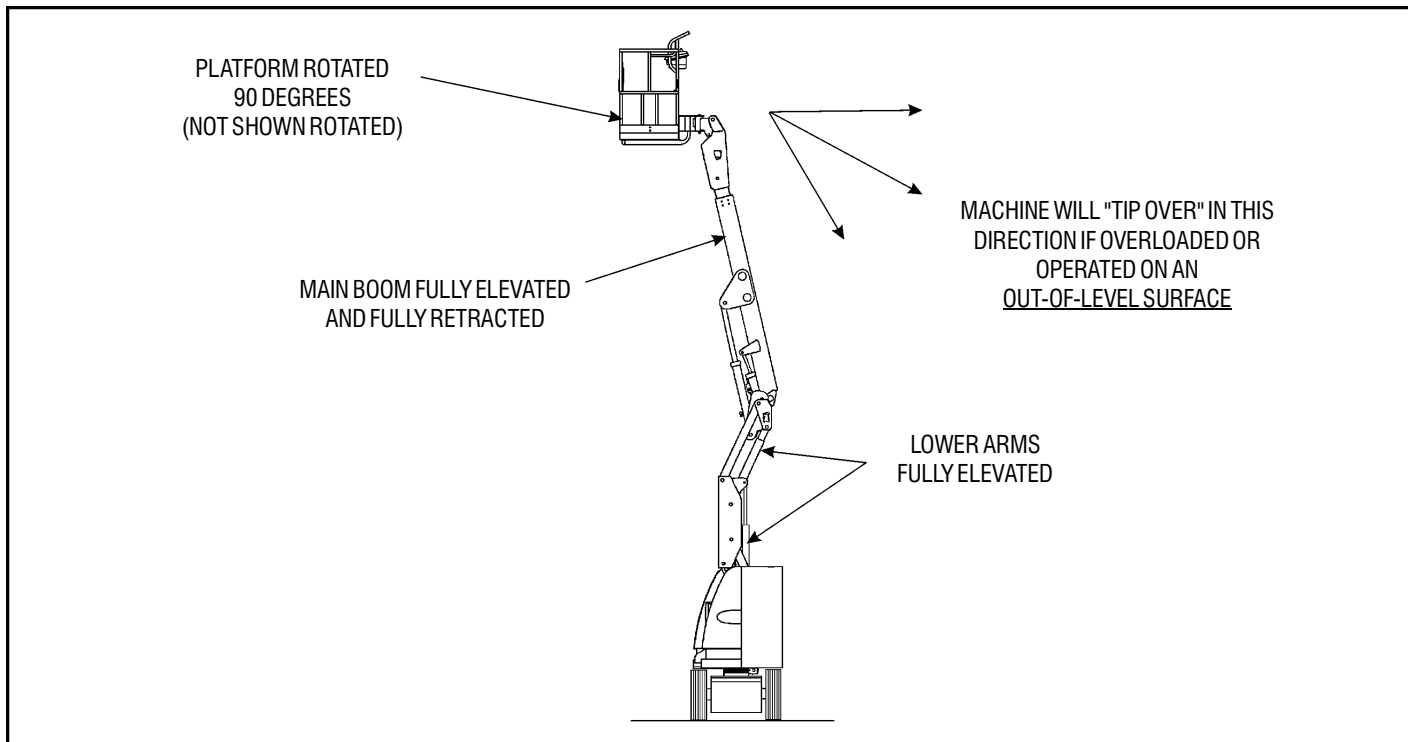

Figure 4-2. Position Of Least Backward Stability

## Motor Activation

### **NOTICE**

FOOTSWITCH MUST BE DEPRESSED PRIOR TO ACTIVATING ANY FUNCTION, OTHERWISE FUNCTION WILL NOT OPERATE.

The motor becomes activated and operates the desired function when the Emergency Stop switch is pulled out (on), the Platform/Ground select switch is in the appropriate position and the Footswitch is depressed.

### **⚠ CAUTION**

IF A MOTOR MALFUNCTION NECESSITATES UNSCHEDULED SHUT-DOWN, DETERMINE AND CORRECT CAUSE BEFORE RESUMING ANY OPERATION.

### **NOTICE**

ALWAYS POSITION EMERGENCY STOP SWITCH TO THE 'OFF' POSITION (PUSHED IN) WHEN MACHINE IS NOT IN USE.

## 4.4 TRAVELING (DRIVING)

### **NOTICE**

IF THE MACHINE IS OPERATED AT A VERY SLOW SPEED OR STALLED WHEN CLIMBING A GRADE OF 20% OR GREATER, DRIVE FUNCTION WILL STOP. REMOVE FOOT FROM FOOT-SWITCH, AND DEPRESS FOOT-SWITCH TO RESET.

### **⚠ WARNING**

DO NOT DRIVE WITH BOOM ABOVE HORIZONTAL EXCEPT ON A SMOOTH, FIRM AND LEVEL SURFACE.

DO NOT DRIVE ON SIDE SLOPES EXCEEDING 5 DEGREES

AVOID ANY TERRAIN FEATURES WHICH COULD CAUSE THE MACHINE TO TIPOVER.

USE EXTREME CAUTION WHEN DRIVING IN REVERSE AND AT ALL TIMES WHEN DRIVING WITH PLATFORM ELEVATED AND WHEN DRIVING WITH ANY PART OF MACHINE WITHIN 6 FEET OF ANY OBSTRUCTION. DO NOT USE DRIVE TO MANEUVER PLATFORM CLOSE TO AN OBSTRUCTION...USE ONE OF THE BOOM FUNCTIONS.

### **⚠ CAUTION**

BEFORE DRIVING, MAKE SURE BOOM IS POSITIONED OVER REAR DRIVE AXLE. IF BOOM IS OVER STEER WHEELS, STEER AND DRIVE CONTROLS WILL MOVE IN OPPOSITE DIRECTIONS TO MACHINE MOTION.

### **Traveling Forward and Reverse**

### **NOTICE**

FOOTSWITCH MUST BE DEPRESSED PRIOR TO ACTIVATING ANY FUNCTION, OTHERWISE FUNCTION WILL NOT OPERATE.

1. If machine is shut down, pull out Emergency Stop at Ground Controls and place Platform/Ground Select switch to PLATFORM.
2. At Platform Controls, pull out Emergency Stop switch and activate footswitch.
3. Position Drive controller to FORWARD or REVERSE as desired. Angle of controller will determine travel speed.

## 4.5 STEERING

Depress footswitch to steer machine, position thumb switch on Drive/Steer controller to RIGHT for steering right, or to LEFT for steering left.

## 4.6 PLATFORM

### **Loading From Ground Level**

1. Position chassis on a smooth, firm and level surface.
2. If total load (personnel, tools and supplies) is 500 LB. (227 kg) or less, distribute load uniformly on platform floor and proceed to work position.

### **Loading From Positions Above Ground Level**

Before loading weight to platform above ground level:

1. Determine what the total weight will be after additional weight is loaded (personnel, tools and supplies).
2. If total weight in platform will be 500 LBS. (227 kg) or less, proceed with adding weight.

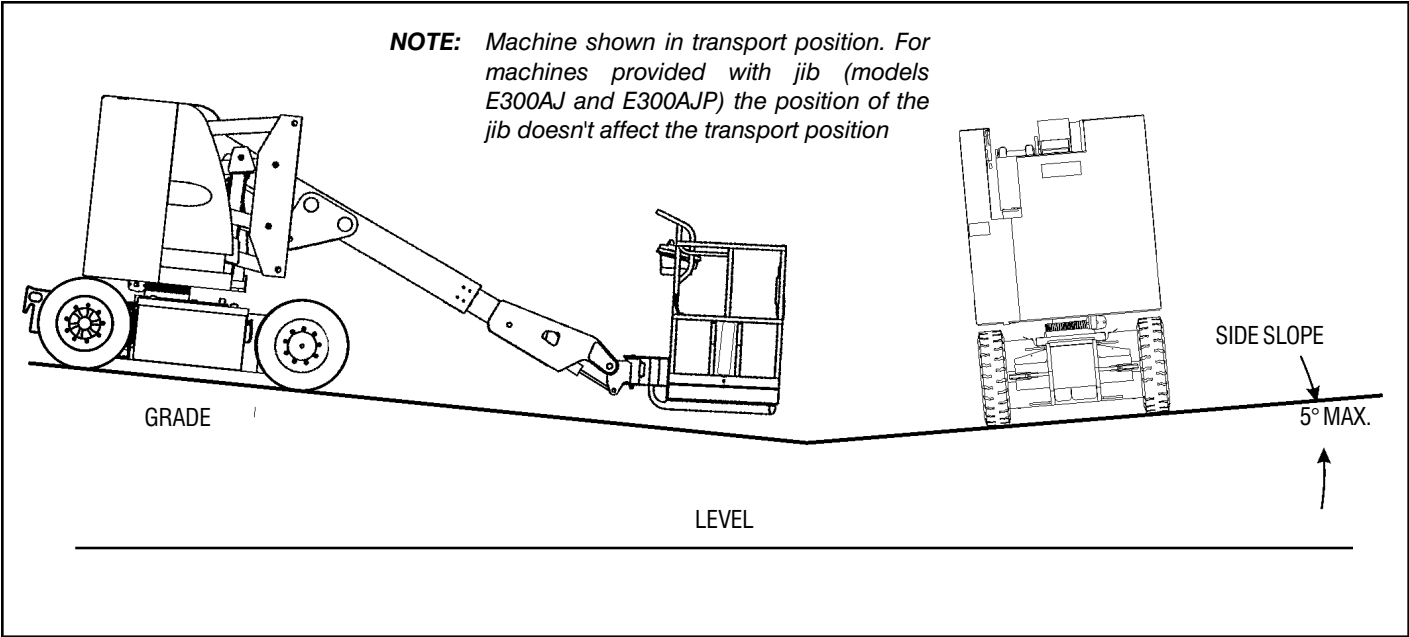

Figure 4-3. Grade and Side Slopes

### Platform Level Adjustment

#### **WARNING**

ONLY USE THE PLATFORM LEVELING OVERRIDE FUNCTION FOR SLIGHT LEVELING OF THE PLATFORM. INCORRECT USE COULD CAUSE THE LOAD/OCCUPANTS TO SHIFT OR FALL. FAILURE TO DO SO COULD RESULT IN DEATH OR SERIOUS INJURY.

1. Leveling UP. Depress footswitch to raise platform, position PLATFORM/LEVEL control switch UP and hold until platform is level.
2. Leveling DOWN. Depress footswitch to lower platform, position PLATFORM/LEVEL control switch to DOWN and hold until platform is level.

### Platform Rotation

1. Depress footswitch to rotate platform to the left, PLATFORM ROTATE control switch is positioned to the LEFT and held until desired position is reached.
2. Depress footswitch to rotate platform to the right, PLATFORM ROTATE control switch is positioned to the RIGHT and held until desired position is reached.

### 4.7 BOOM

#### **WARNING**

A RED TILT WARNING LIGHT IS LOCATED ON THE CONTROL CONSOLE WHICH LIGHTS WHEN THE CHASSIS IS ON A 5 DEGREE OR GREATER SLOPE. DO NOT SWING OR RAISE BOOM ABOVE HORIZONTAL WHEN LIGHT IS LIT.

DO NOT DEPEND ON TILT ALARM AS A LEVEL INDICATOR FOR THE CHASSIS. TILT ALARM INDICATES CHASSIS IS ON A SEVERE SLOPE (5 DEGREE OR GREATER). CHASSIS MUST BE LEVEL BEFORE SWINGING, OR RAISING BOOM ABOVE HORIZONTAL.

TO AVOID UPSET IF RED TILT WARNING LIGHT LIGHTS WHEN BOOM IS RAISED ABOVE HORIZONTAL, LOWER PLATFORM TO GROUND LEVEL. THEN REPOSITION MACHINE SO THAT CHASSIS IS LEVEL BEFORE RAISING BOOM.

TRAVELING WITH BOOM BELOW HORIZONTAL IS PERMITTED ON GRADES AND SIDE SLOPES SPECIFIED ON SERIAL NAMEPLATE ON THE FRAME.

**⚠ CAUTION**

**TO AVOID SERIOUS INJURY, DO NOT OPERATE MACHINERY IF ANY CONTROL LEVER OR TOGGLE SWITCH CONTROLLING PLATFORM MOVEMENT DOES NOT RETURN TO THE 'OFF' OR NEUTRAL POSITION WHEN RELEASED.**

**TO AVOID A COLLISION AND INJURY IF PLATFORM DOES NOT STOP WHEN A CONTROL SWITCH OR LEVER IS RELEASED, REMOVE FOOT FROM FOOTSWITCH OR USE EMERGENCY STOP SWITCH TO STOP THE MACHINE.**

## **Swinging the Boom**

Depress footswitch to swing boom, with footswitch activated, position SWING control switch to RIGHT or LEFT for direction desired.

**NOTICE**

**WHEN SWINGING THE BOOM MAKE SURE THERE IS AMPLE ROOM FOR THE BOOM TO CLEAR SURROUNDING WALLS, PARTITIONS AND EQUIPMENT.**

## **Raising and Lowering the Upper Boom**

Depress footswitch to raise or lower the Upper Boom, with footswitch activated, position Upper Boom Lift switch to UP or DOWN until desired height is reached.

## **4.8 BOOM FUNCTION SPEEDS**

The Function Speed Control affects the speed of boom functions LIFT, TELESCOPE, and SWING. Turn the control CW to increase function speed or CCW to decrease function speed.

## SECTION 4 - MACHINE OPERATION

---

### 4.9 SHUT DOWN AND PARK

**NOTE:** When parking battery powered units overnight, batteries should be charged in accordance with instructions in Section 6 to ensure readiness for following workday.

**NOTE:** Electric machines are equipped with a static strap due to static electricity build-ups. Strap is located under rear of machine chassis.

To shut down and park the machine, the procedures are as follows:

1. Drive machine to a reasonably well protected area.
2. Ensure boom is lowered over rear drive axle.
3. Shut down Emergency Stop at Platform Controls.
4. Shut down Emergency Stop at Ground Controls. Position Platform/Ground Select switch to center OFF.
5. If necessary, cover Platform Controls to protect instruction placards, warning decals and operating controls from hostile environment.

### 4.10 LIFTING AND TIE DOWN

#### Lifting

1. Refer to the Serial Number Tag, call JLG Industries, or weigh the individual unit to find out the Gross Vehicle Weight.
2. Place the boom in the stowed position.
3. Remove all loose items from the machine.
4. Properly adjust the rigging to prevent damage to the machine and so the machine remains level.

#### Tie Down

#### **NOTICE**

**WHEN TRANSPORTING THE MACHINE, THE BOOM MUST BE FULLY LOWERED INTO THE BOOM REST.**

1. Place the boom in the stowed position.
2. Remove all loose items from the machine.
3. Secure the chassis and the platform using straps or chains of adequate strength.



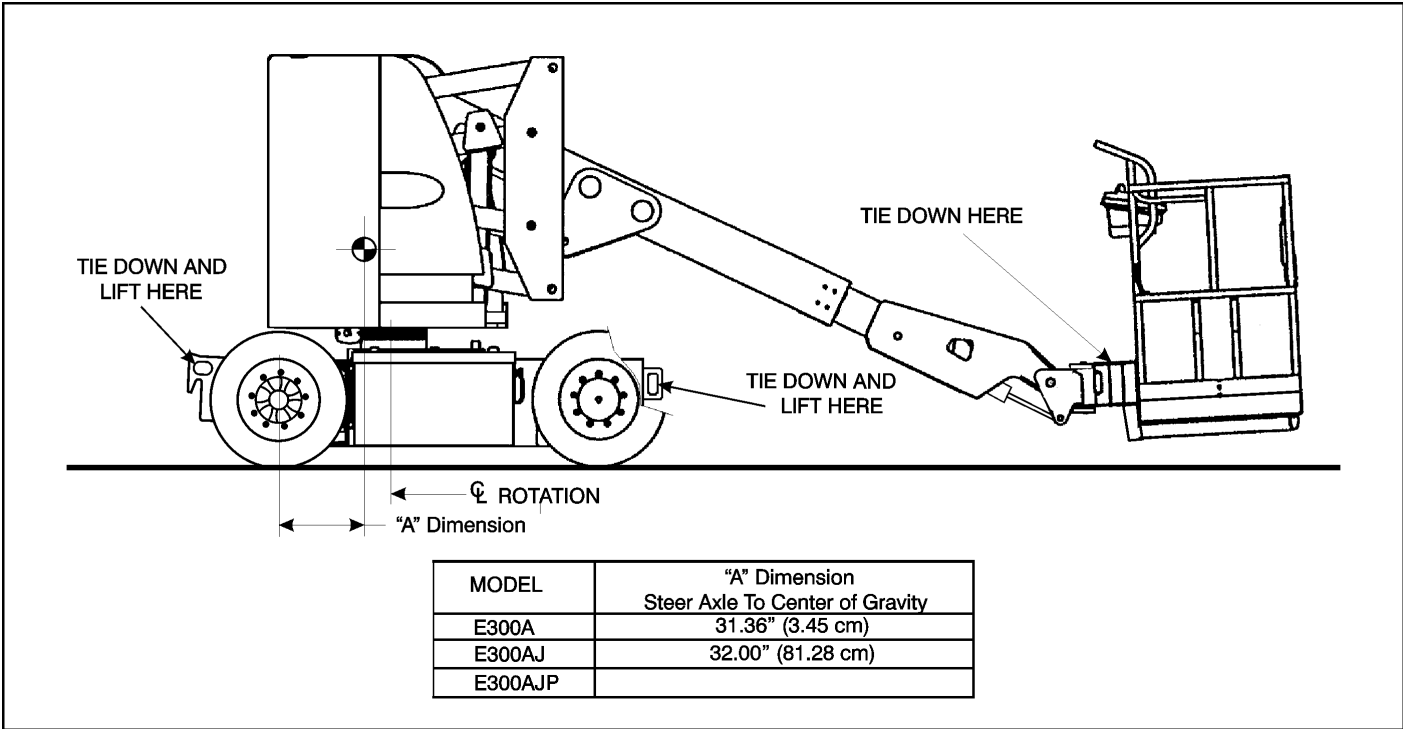

Figure 4-4. Lifting Chart

## SECTION 4 - MACHINE OPERATION

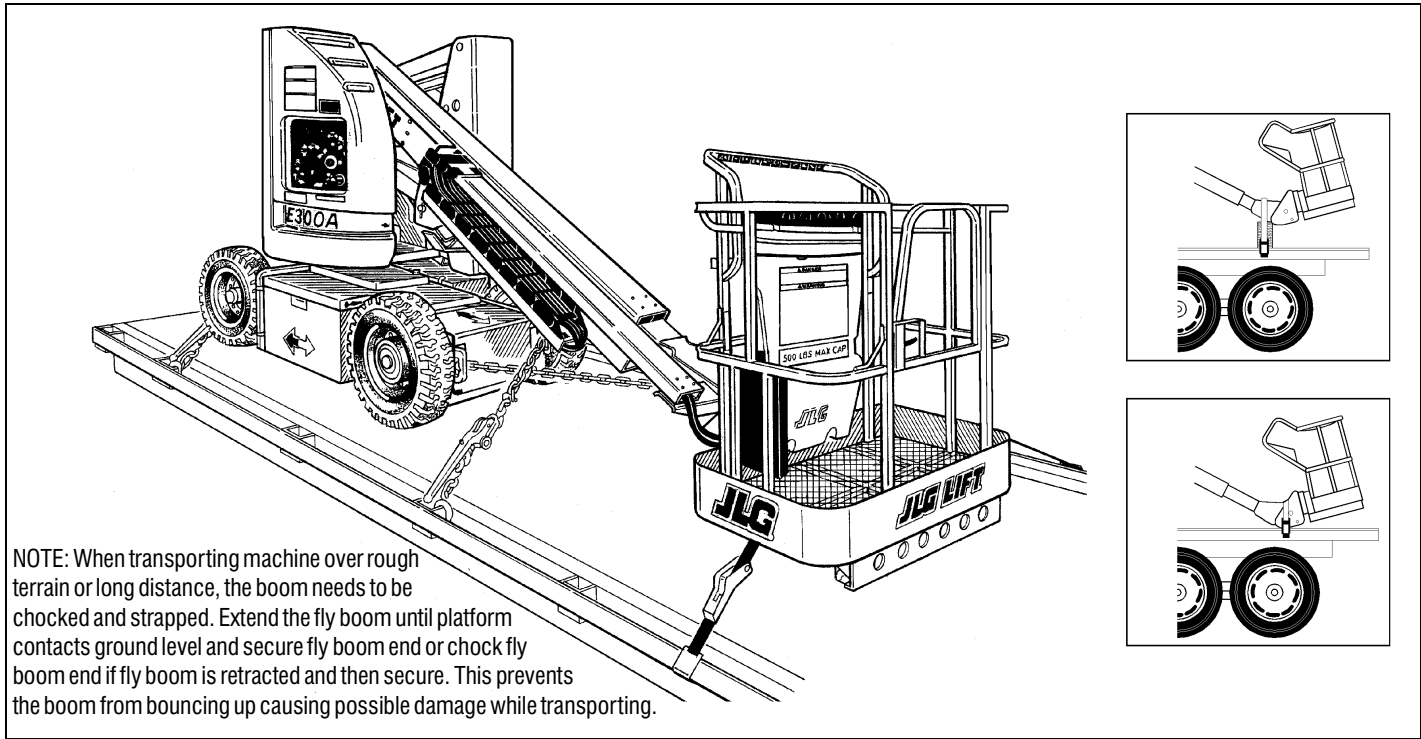

Figure 4-5. Machine Tie Down

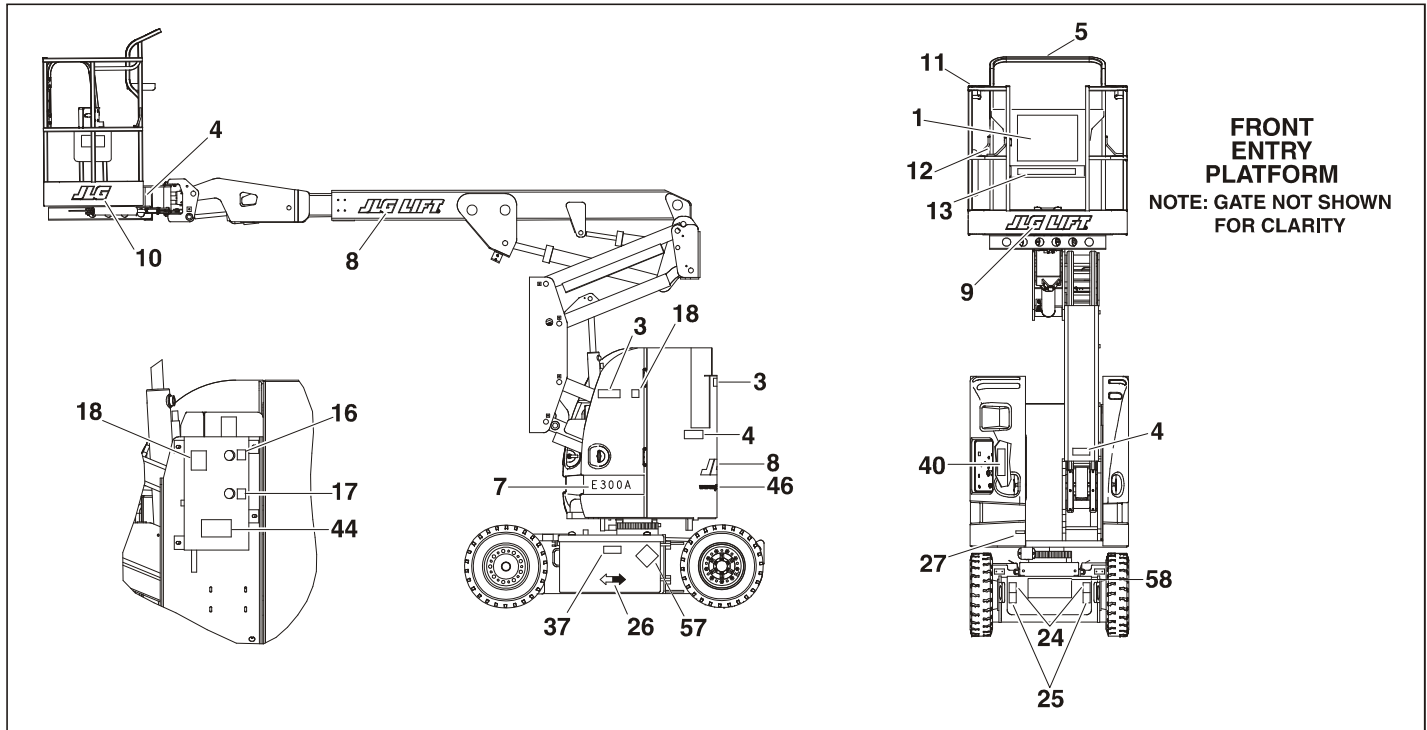

Figure 4-6. Decal Installation - Sheet 1 of 3

## SECTION 4 - MACHINE OPERATION

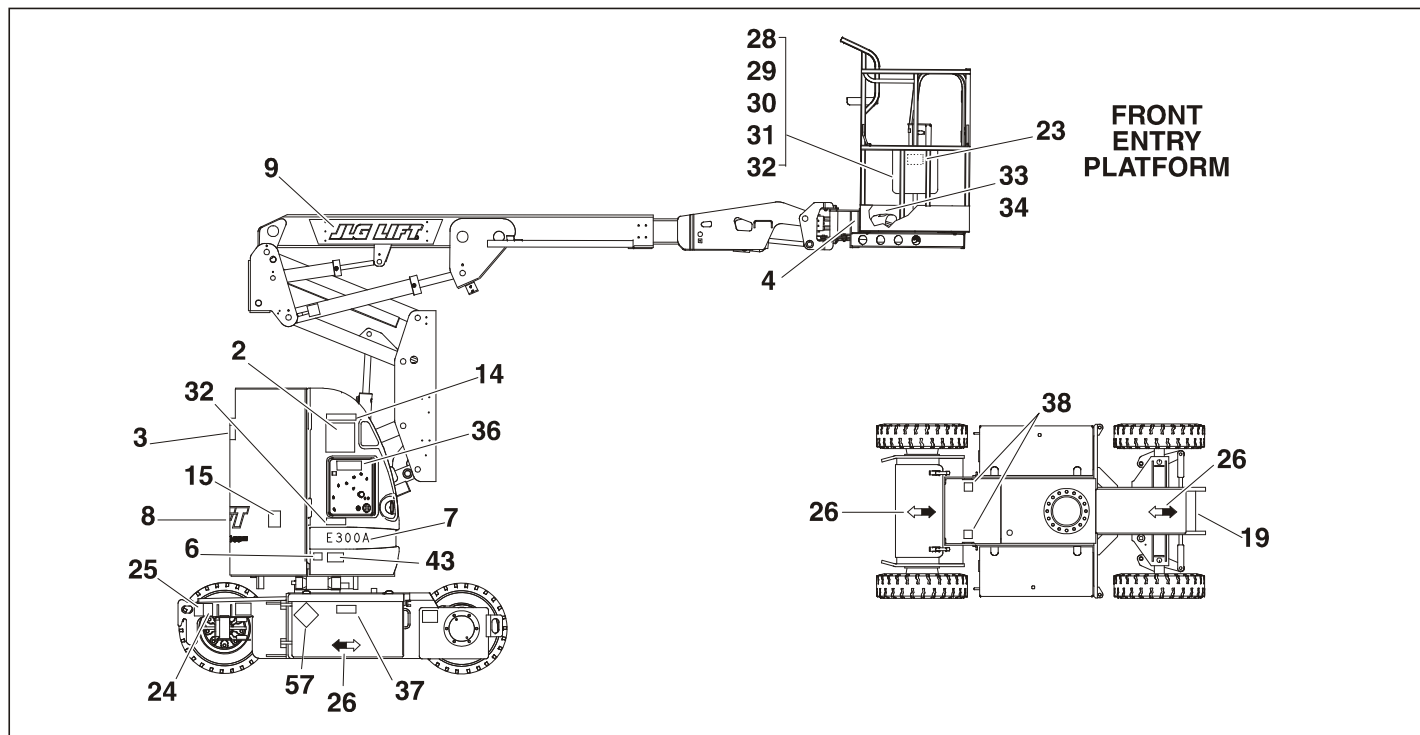

Figure 4-7. Decal Installation - Sheet 2 of 3

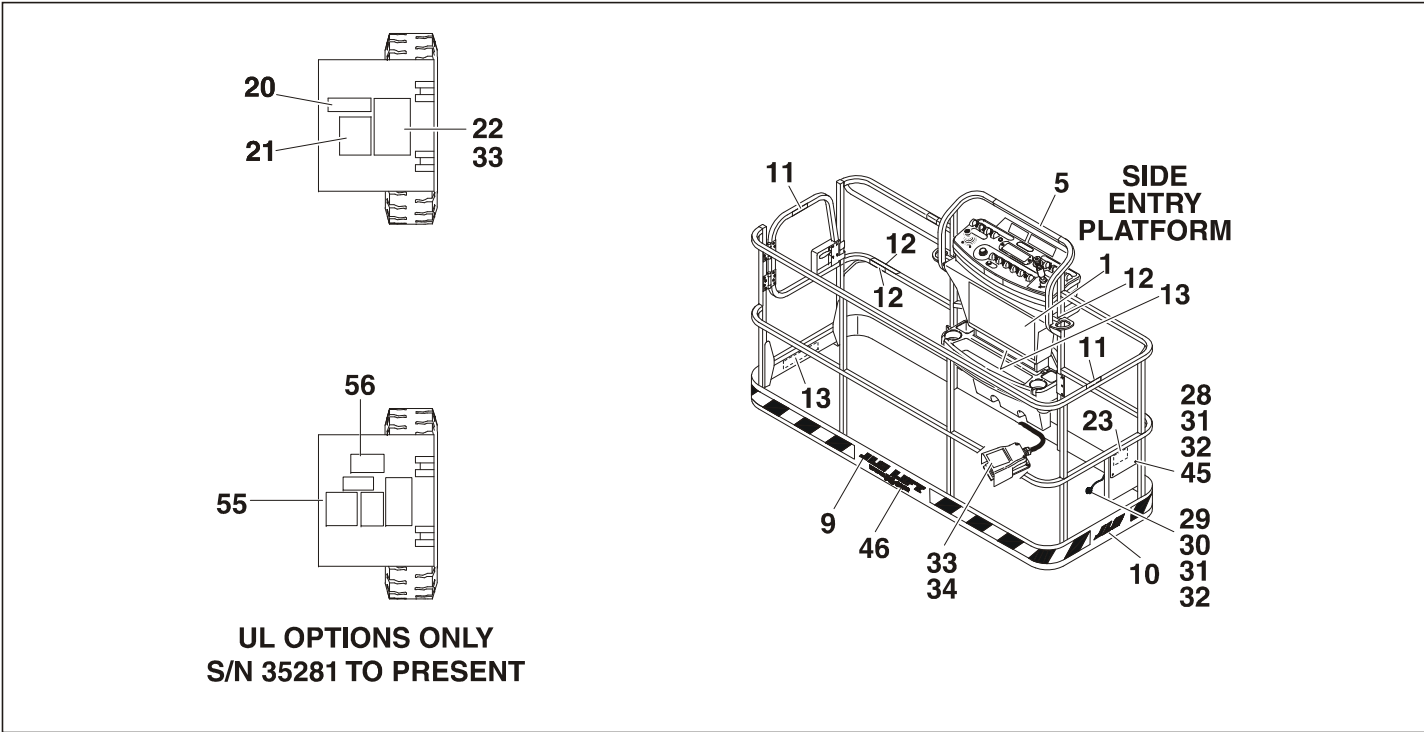

Figure 4-8. Decal Installation - Sheet 3 of 3

## SECTION 4 - MACHINE OPERATION

---

Table 4-1. E300A Decal Legend - Part 1 of 2

Item #	ANSI 0259007-9	Australian 0259009-4	CE English 0259314-5	German 0259013-5	Dutch 0259015-5	Italian 0259017-5	French 0259019-5	Spanish 0259021-5
1	1703797	1703992	1703806	1703799	1703913	1703915	1703917	1703919
2	1703798	1703807	1703807	1703800	1703914	1703916	1703918	1703920
3	1703805	--	--	--	--	--	--	--
4	1703804	1701518	1701518	1701518	1701518	1701518	1701518	1701518
5	1704253	--	--	--	--	--	--	--
6	1701644	1701644	1701644	1701644	1701644	1701644	1701644	1701644
7	--	--	--	--	--	--	--	--
8	--	--	--	--	--	--	--	--
9	--	--	--	--	--	--	--	--
10	--	--	--	--	--	--	--	--
11	1702860	--	--	--	--	--	--	--
12	1704277	1704277	1704277	1704277	1704277	1704277	1704277	1704277
13	1701645	--	--	--	--	--	--	--

**SECTION 4 - MACHINE OPERATION**

**Table 4-1. E300A Decal Legend - Part 1 of 2**

<b>Item #</b>	<b>ANSI 0259007-9</b>	<b>Australian 0259009-4</b>	<b>CE English 0259314-5</b>	<b>German 0259013-5</b>	<b>Dutch 0259015-5</b>	<b>Italian 0259017-5</b>	<b>French 0259019-5</b>	<b>Spanish 0259021-5</b>
14	1702688	--	--	--	--	--	--	--
15	--	--	--	--	--	--	--	--
16	1701502	1701502	1701502	1701502	1701502	1701502	1701502	1701502
17	1701503	1701503	1701503	1701503	1701503	1701503	1701503	1701503
18	1701504	1701504	1701504	1701504	1701504	1701504	1701504	1701504
19	1702153	--	--	--	--	--	--	--
20	1702631	1702631	1702631	1702631	1702631	1702631	1702631	1702631
21	1700584	1700584	1700584	1700584	1700584	1700584	1700584	1700584
22	--	--	--	--	--	--	--	--
23	1701509	1701509	1701509	1701509	1701509	1701509	1701509	1701509
24	1702300	1702300	1702300	1702300	1702300	1702300	1702300	1702300
25	1701500	1701500	1701500	1701500	1701500	1701500	1701500	1701500
26	1701529	1701529	1701529	1701529	1701529	1701529	1701529	1701529
27	--	--	--	--	--	--	--	--

## SECTION 4 - MACHINE OPERATION

Table 4-1. E300A Decal Legend - Part 1 of 2

Item #	ANSI 0259007-9	Australian 0259009-4	CE English 0259314-5	German 0259013-5	Dutch 0259015-5	Italian 0259017-5	French 0259019-5	Spanish 0259021-5
28	--	--	--	--	--	--	--	--
29	--	--	--	--	--	--	--	--
30	--	--	--	--	--	--	--	--
31	--	--	--	--	--	--	--	--
32	--	--	--	--	--	--	--	--
33	--	--	--	--	--	--	--	--
34	--	--	--	1693294	1703518	1701600	1693292	1701791
35	--	1704276	1704276	1704276	1704276	1704276	1704276	1704276
36	1704248	1704248	1704248	1704323	1704324	1704325	1704326	1704327
37	1703813	1703813	1703813	1704334	1704335	1704336	1704337	1704338
38	1702155	1702155	1702155	1702155	1702155	1702155	1702155	1702155
39	--	--	--	--	--	--	--	--
40	1705085	1705085	1705085	1705085	1705085	1705085	1705085	1705085
41	--	--	--	--	--	--	--	--



**Table 4-1. E300A Decal Legend - Part 1 of 2**

<b>Item #</b>	<b>ANSI 0259007-9</b>	<b>Australian 0259009-4</b>	<b>CE English 0259314-5</b>	<b>German 0259013-5</b>	<b>Dutch 0259015-5</b>	<b>Italian 0259017-5</b>	<b>French 0259019-5</b>	<b>Spanish 0259021-5</b>
42	--	--	--	--	--	--	--	--
43	1702901	1702901	1702901	1702901	1702901	1702901	1702901	1702901
44	1704412	1704412	1704412	1704412	1704412	1704412	1704412	1704412

## SECTION 4 - MACHINE OPERATION

---

Table 4-2. E300A Decal Legend - Part 2 of 2

Item #	Japanese 0259023-4	Korean 0259025-5	ANSI English/ Spanish 0259027-5	ANSI Chinese/ English 0259031-5	ANSI Portuguese/ Spanish 0259035-6	Norwegian 0273209-2
1	1703926	1703927	1703923	1703925	1703928	1705254
2	1703932	1703933	1703929	1703931	1703934	1705255
3	1703938	1703939	1703935	1703937	1703940	--
4	1703950	1703951	1703947	1703949	1703952	1701518
5	--	--	1704253	--	--	--
6	1701644	1701644	1701644	1701644	1701644	1701644
7	--	--	--	--	--	--
8	--	--	--	--	--	--
9	--	--	--	--	--	--
10	--	--	--	--	--	--
11	--	--	--	--	1704002	--
12	1704277	1704277	1704277	1704277	1704277	1704277
13	1703996	1703996	1703996	1703996	1703996	--

**SECTION 4 - MACHINE OPERATION****Table 4-2. E300A Decal Legend - Part 2 of 2**

<b>Item #</b>	<b>Japanese 0259023-4</b>	<b>Korean 0259025-5</b>	<b>ANSI English/ Spanish 0259027-5</b>	<b>ANSI Chinese/ English 0259031-5</b>	<b>ANSI Portuguese/ Spanish 0259035-6</b>	<b>Norwegian 0273209-2</b>
14	--	--	1702688	--	--	--
15	--	--	--	--	--	--
16	1701502	1701502	1701502	1701502	1701502	1701502
17	1701503	1701503	1701503	1701503	1701503	1701503
18	1701504	1701504	1701504	1701504	1701504	1701504
19	--	--	1704007	--	1704008	--
20	1702631	1702631	1702631	1702631	1702631	1702631
21	1700584	1700584	1700584	1700584	1700584	1700584
22	--	--	--	--	--	--
23	1701509	1701509	1701509	1701509	1701509	1701509
24	1702300	1702300	1702300	1702300	1702300	1702300
25	1701500	1701500	1701500	1701500	1701500	1701500
26	1701529	1701529	1701529	1701529	1701529	1701529
27	--	--	--	--	--	--

## SECTION 4 - MACHINE OPERATION

---

Table 4-2. E300A Decal Legend - Part 2 of 2

Item #	Japanese 0259023-4	Korean 0259025-5	ANSI English/ Spanish 0259027-5	ANSI Chinese/ English 0259031-5	ANSI Portuguese/ Spanish 0259035-6	Norwegian 0273209-2
28	--	--	--	--	--	--
29	--	--	--	--	--	--
30	--	--	--	--	--	--
31	--	--	--	--	--	--
32	--	--	--	--	--	--
33	--	--	--	--	--	--
34	1703980	1703981	1703983	1703982	1703985	1705275
35	1704276	1704276	1704276	1703809	--	1704276
36	1704331	1704332	1704328	1704333	1704330	1705259
37	1704342	1704343	1704339	1704344	1704341	1705256
38	1702155	1702155	1702155	1702155	1702155	1702155
39	--	--	--	--	--	--
40	1705085	1705085	1705085	1705085	1705085	1705085
41	--	--	--	--	--	--

**Table 4-2. E300A Decal Legend - Part 2 of 2**

<b>Item #</b>	<b>Japanese 0259023-4</b>	<b>Korean 0259025-5</b>	<b>ANSI English/ Spanish 0259027-5</b>	<b>ANSI Chinese/ English 0259031-5</b>	<b>ANSI Portuguese/ Spanish 0259035-6</b>	<b>Norwegian 0273209-2</b>
42	--	--	--	--	--	--
43	1702901	1702901	1702901	1702901	1702901	1705246
44	1704412	1704412	1704412	1704412	1704412	1704412

## SECTION 4 - MACHINE OPERATION

---

Table 4-3. E300AJ Decal Legend

Item #	ANSI 0259008-7	CE/Aus 0275064-3	Japanese 0259024-5	Korean 0259026-6	Spanish 0259028-6	French 0259030-6	Chinese 0259032-6	Portuguese/ Spanish 0259036-6
1	1703797	1705921	1703926	1703927	1703923	1703924	1703925	1703928
2	1703798	1705822	1703932	1703933	1703929	1703930	1703931	1703934
3	1703805	--	1703938	1703939	1703935	1703936	1703937	1703940
4	1703804	1701518	1703950	1703951	1703947	1703948	1703949	1703952
5	1704253	--	--	--	1704253	1704253	--	--
6	1701644	1701644	1701644	1701644	1701644	1701644	1701644	1701644
7	--	1704199	--	--	--	--	--	--
8	--	--	--	--	--	--	--	--
9	--	--	--	--	--	--	--	--
10	--	--	--	--	--	--	--	--
11	1702868	--	--	--	--	1704000	--	1704002
12	1704277	1704277	1704277	1704277	1704277	1704277	1704277	1704277
13	1701645	1705978	1707059	1707058	1707056	1707055	1707060	1707057

**Table 4-3. E300AJ Decal Legend**

<b>Item #</b>	<b>ANSI 0259008-7</b>	<b>CE/Aus 0275064-3</b>	<b>Japanese 0259024-5</b>	<b>Korean 0259026-6</b>	<b>Spanish 0259028-6</b>	<b>French 0259030-6</b>	<b>Chinese 0259032-6</b>	<b>Portuguese/ Spanish 0259036-6</b>
14	1707013	--	--	--	1707013	1707047	--	1707013
15	--	--	--	--	--	--	--	--
16	1701502	1701502	1701502	1701502	1701502	1701502	1701502	1701502
17	1701503	1701503	1701503	1701503	1701503	1701503	1701503	1701503
18	1701504	1701504	1701504	1701504	1701504	1701504	1701504	1701504
19	1702153	--	--	--	1704007	1704006	--	1704008
20	1702631	1702631	1702631	1702631	1702631	1702631	1702631	1702631
21	1700584	1700584	1700584	1700584	1700584	1700584	1700584	1700584
22	1706948	3252799	1706948	1706948	1706948	1706948	1706948	1706948
23	1701509	1701509	1701509	1701509	1701509	1701509	1701509	1701509
24	1702300	1703814	1702300	1702300	1702300	1702300	1702300	1702300
25	1701500	1703811	1701500	1701500	1701500	1701500	1701500	1701500
26	1701529	1701642	1701529	1701529	1701529	1701529	1701529	1701529
27	--	--	--	--	--	--	--	--

## SECTION 4 - MACHINE OPERATION

Table 4-3. E300AJ Decal Legend

Item #	ANSI 0259008-7	CE/Aus 0275064-3	Japanese 0259024-5	Korean 0259026-6	Spanish 0259028-6	French 0259030-6	Chinese 0259032-6	Portuguese/ Spanish 0259036-6
28	--	--	--	--	--	--	--	--
29	--	--	--	--	--	--	--	--
30	--	--	--	--	--	--	--	--
31	--	--	--	--	--	--	--	--
32	--	--	--	--	--	--	--	--
33	--	--	--	--	--	--	--	--
34	--	1705828	1703980	1703981	1703983	1703984	1703982	1703985
35	--	1704276	1704276	1704276	1704276	--	1703809	--
36	1704248	1706378	1704331	1704332	1704328	1704329	1704333	1704330
37	1703813	1705670	1704342	1704343	1704339	1704340	1704344	1704341
38	1702155	1702155	1702155	1702155	1702155	1702155	1702155	1702155
39	--	--	--	--	--	1705514	--	--
40	1705085	1705085	1705085	1705085	1705085	1705085	1705085	1705085
41	--	--	--	--	--	--	--	--



**Table 4-3. E300AJ Decal Legend**

<b>Item #</b>	<b>ANSI 0259008-7</b>	<b>CE/Aus 0275064-3</b>	<b>Japanese 0259024-5</b>	<b>Korean 0259026-6</b>	<b>Spanish 0259028-6</b>	<b>French 0259030-6</b>	<b>Chinese 0259032-6</b>	<b>Portuguese/ Spanish 0259036-6</b>
42	--	--	--	--	--	--	--	--
43	1702901	1706932	1702901	1702901	1702901	1704116	1702901	1702901
44	1704412	1704412	1704412	1704412	1704412	1704412	1704412	1704412
45	--	--						
46	--	1704885						

## SECTION 4 - MACHINE OPERATION

---

Table 4-4. E300AJP Decal Legend

Item #	ANSI 0259506-7	CE/Aus 0275065-3	Japanese 0259514-4	Korean 0259515-5	Spanish 0259516-5	French 0259517-6	Chinese 0259518-5	Portuguese/ Spanish 0259519-5
1	1703797	1705921	1703926	1703927	1703923	1703924	1703925	1703928
2	1703798	1705822	1703932	1703933	1703929	1703930	1703931	1703934
3	1703805	--	1703938	1703939	1703935	1703936	1703937	1703940
4	1703804	1701518	1703950	1703951	1703947	1703948	1703949	1703952
5	1704253	--	--	--	1704253	1704253	--	--
6	1701644	1701644	1701644	1701644	1701644	1701644	1701644	1701644
7	--	1704267	--	--	--	--	--	--
8	--	--	--	--	--	--	--	--
9	--	--	--	--	--	--	--	--
10	--	--	--	--	--	--	--	--
11	1702868	--	--	--	--	1704000	--	1704002
12	1704277	1704277	1704277	1704277	1704277	1704277	1704277	1704277
13	1701645	1705978	1703996	1703996	1703996	1703996	1703996	1703996

**Table 4-4. E300AJP Decal Legend**

<b>Item #</b>	<b>ANSI 0259506-7</b>	<b>CE/Aus 0275065-3</b>	<b>Japanese 0259514-4</b>	<b>Korean 0259515-5</b>	<b>Spanish 0259516-5</b>	<b>French 0259517-6</b>	<b>Chinese 0259518-5</b>	<b>Portuguese/ Spanish 0259519-5</b>
14	1707013	--	--	--	1702688	1704112	--	--
15	--	--	--	--	--	--	--	--
16	1701502	1701502	1701502	1701502	1701502	1701502	1701502	1701502
17	1701503	1701503	1701503	1701503	1701503	1701503	1701503	1701503
18	1701504	1701504	1701504	1701504	1701504	1701504	1701504	1701504
19	1702153	--	--	--	1704007	1704006	--	1704008
20	1702631	1702631	1702631	1702631	1702631	1702631	1702631	1702631
21	1700584	1700584	1700584	1700584	1700584	1700584	1700584	1700584
22	1706948	3252799	--	--	--	--	--	--
23	1701509	1701509	1701509	1701509	1701509	1701509	1701509	1701509
24	1702300	1703814	1702300	1702300	1702300	1702300	1702300	1702300
25	1701500	1703811	1701500	1701500	1701500	1701500	1701500	1701500
26	1701529	1701642	1701529	1701529	1701529	1701529	1701529	1701529
27	--	--	--	--	--	--	--	--

## SECTION 4 - MACHINE OPERATION

---

Table 4-4. E300AJP Decal Legend

Item #	ANSI 0259506-7	CE/Aus 0275065-3	Japanese 0259514-4	Korean 0259515-5	Spanish 0259516-5	French 0259517-6	Chinese 0259518-5	Portuguese/ Spanish 0259519-5
28	--	--	--	--	--	--	--	--
29	--	--	--	--	--	--	--	--
30	--	--	--	--	--	--	--	--
31	--	--	--	--	--	--	--	--
32	--	--	--	--	--	--	--	--
33	--	--	--	--	--	--	--	--
34	--	1705828	1703980	1703981	1703983	1703984	1703982	1703985
35	--	1704276	1704276	1704276	1704276	--	1703809	--
36	1704248	1706378	1704331	1704332	1704328	1704329	1704333	1704330
37	1703813	1705670	1704342	1704343	1704339	1704340	1704344	1704341
38	1702155	1702155	1702155	1702155	1702155	1702155	1702155	1702155
39	--	--	--	--	--	1705514	--	--
40	1705085	1705085	1705085	1705085	1705085	1705085	1705085	1705085
41	--	--	--	--	--	--	--	--

**Table 4-4. E300AJP Decal Legend**

<b>Item #</b>	<b>ANSI 0259506-7</b>	<b>CE/Aus 0275065-3</b>	<b>Japanese 0259514-4</b>	<b>Korean 0259515-5</b>	<b>Spanish 0259516-5</b>	<b>French 0259517-6</b>	<b>Chinese 0259518-5</b>	<b>Portuguese/ Spanish 0259519-5</b>
42	--	--	--	--	--	--	--	--
43	1702901	1706932	1702901	1702901	1702901	1704116	1702901	1702901
44	1704412	1704412	1704412	1704412	1704412	1704412	1704412	1704412
45		--						
46		1704885						



## **SECTION 5. EMERGENCY PROCEDURES**

### **5.1 GENERAL**

This section explains the steps to be taken in case of an emergency situation while operating.

Failure to notify the manufacturer of an incident involving a JLG Industries product within 48 hours of such an occurrence may void any warranty consideration on that particular machine.

### **5.2 INCIDENT NOTIFICATION**

JLG Industries, Inc. must be notified immediately of any incident involving a JLG product. Even if no injury or property damage is evident, the factory should be contacted by telephone and provided with all necessary details.

In USA:

JLG Phone: 877-JLG-SAFE (554-7233)  
(8am till 4:45pm EST)

Outside USA:

240-420-2661

E-mail:

ProductSafety@JLG.com

#### **NOTICE**

**FOLLOWING ANY ACCIDENT, THOROUGHLY INSPECT THE MACHINE AND TEST ALL FUNCTIONS FIRST FROM THE GROUND CONTROLS, THEN FROM THE PLATFORM CONTROLS. DO NOT LIFT ABOVE 10 FT. (3 M) UNTIL YOU ARE SURE THAT ALL DAMAGE HAS BEEN REPAIRED, IF REQUIRED, AND THAT ALL CONTROLS ARE OPERATING CORRECTLY.**

### 5.3 EMERGENCY OPERATION

#### Operator Unable to Control Machine

IF THE PLATFORM OPERATOR IS PINNED, TRAPPED OR UNABLE TO OPERATE OR CONTROL MACHINE:

1. Other personnel should operate the machine from ground controls only as required.
2. Other qualified personnel on the platform may use the platform controls. DO NOT CONTINUE OPERATION IF CONTROLS DO NOT FUNCTION PROPERLY.

#### Platform or Boom Caught Overhead

If the platform or boom becomes jammed or snagged in overhead structures or equipment, rescue platform occupants prior to freeing the machine.

### 5.4 EMERGENCY TOWING PROCEDURES

Towing this machine is prohibited. However, provisions for moving the machine have been incorporated. The following procedures are to be used ONLY for emergency movement to a suitable maintenance area.

1. Chock wheels securely.
2. Engage the mechanical release on both drive hubs by loosening, completely reversing, and tightening the two bolts on each hub.
3. Connect suitable equipment, remove chocks, and move machine.

After moving machine, complete the following procedure:

4. Position machine on a firm level surface.
5. Chock wheels securely.
6. Disengage the mechanical release on both drive hubs by loosening, completely reversing, and tightening the two bolts on each hub.
7. Remove chocks from wheels as desired.
8. DO NOT EXCEED 3 MPH.



### 5.5 MANUAL DESCENT SYSTEM

The manual descent system is used, in the event of total power failure or in case the key is not accessible to the ground personnel, to lower the upper, lower and jib booms using gravity. To operate the manual descent system, proceed as follows:

Machines built Prior to S/N 0300063313 and from S/N 0300127575 to Present.

1. Locate the manual descent knob on main valve and turn (clockwise) to open. Install handle into manual descent pump and lower the lower boom by pumping the handle until the boom is completely lowered.
2. Turn manual descent knob (counterclockwise) to close and lower the upper boom by pumping the handle until it is completely lowered. Return the manual descent knob to the center position and stow the handle in bracket provided.

Machines built from S/N 0300063313 to S/N 0300127575.

1. Locate the manual descent knob on main valve and turn (counterclockwise) to open. Install handle into manual descent pump and lower the lower boom by pumping the handle until the boom is completely lowered.
2. Turn manual descent knob (clockwise) to close and lower the upper boom by pumping the handle until it is

completely lowered. Return the manual descent knob to the center position and stow the handle in bracket provided.

### Jib Manual Descent



**DO NOT REACH THROUGH THE JIB SECTION TO ACCESS THE KNOB. ALWAYS ACCESS FROM THE UNDER SIDE OF THE JIB.**

Locate the manual descent knob located on the jib cylinder. Turn the knob counterclockwise until the jib begins to descend. Return the knob to the closed position (clockwise) after the jib is completely lowered.

### Manual Swing Override

The manual swing override is used to manually swing boom and turntable assembly in the event of a total power failure when the platform is positioned over a structure or obstacle. To operate the manual swing override, proceed as follows:

1. Using a 7/8 inch socket and ratchet wrench, locate nut on swing worm gear on left side of machine.
2. Install wrench on nut and ratchet in the direction desired.



## SECTION 6. GENERAL SPECIFICATIONS & OPERATOR MAINTENANCE

### 6.1 INTRODUCTION

This section of the manual provides additional necessary information to the operator for proper operation and maintenance of this machine.

The maintenance portion of this section is intended as information to assist the machine operator to perform daily maintenance tasks only, and does not replace the more thorough Preventive Maintenance and Inspection Schedule included in the Service and Maintenance Manual.

#### Other Publications Available:

- Service and Maintenance Manual - ANSI Spec ..... 3120772
- Service and Maintenance Manual - CE Spec..... 3120887
- Illustrated Parts Manual - ANSI Spec..... 3120773
- Illustrated Parts Manual - CE Spec..... 3120888

### 6.2 OPERATING SPECIFICATIONS

**Table 6-1. Operating specifications - E300A**

Capacity: Unrestricted:	500 lbs. (227 kg)
Maximum Travel Grade, stowed Position (Gradeability) see Figure 4-3.	25%
Maximum Travel Grade, stowed Position (Side Slope) see Figure 4-3.	5%
Vertical Platform Height	30 ft. (9.14 m)
Horizontal Platform Reach (Up & Over)	20 ft. (6.1 m)
Machine Width	4 ft. (1.22 m)
Turning Radius (Outside)	10 ft. (3.05 m)
Turning Radius (Inside)	5 ft. (1.52 m)
Drive Speed (High Drive) (Above Horz.)	45-50 sec/ 200ft. (61 m) 55-68 sec/ 50 ft. (15.2 m)
Gross Machine Weight	14,500 lbs. (6,577 kg)

## SECTION 6 - GENERAL SPECIFICATIONS & OPERATOR MAINTENANCE

**Table 6-1. Operating specifications - E300A**

Ground Bearing Pressure	110 psi (7.7 kg/cm <sup>2</sup> )
Maximum System Voltage	48 VDC
Maximum Main Relief Hyd. Pressure	2500 psi. (172.3 bars)

**Table 6-2. Operating specifications - E300AJ**

Capacity: Unrestricted:	500 lbs. (227 kg)
Maximum Travel Grade, stowed Position (Gradeability) see Figure 4-3.	25%
Maximum Travel Grade, stowed Position (Side Slope) see Figure 4-3.	5%
Vertical Platform Height	30 ft. (9.14 m)
Horizontal Platform Reach (Up & Over)	20 ft. (6.1 m)
Machine Width	4 ft. (1.22 m)
Turning Radius (Outside)	10 ft. (3.05 m)
Turning Radius (Inside)	5 ft. (1.52 m)

**Table 6-2. Operating specifications - E300AJ**

Drive Speed (High Drive) (Above Horz.)	45-50 sec/ 200ft. (61 m) 55-68 sec/ 50 ft. (15.2 m)
Gross Machine Weight	15,400 lbs. (6985 kg)
Ground Bearing Pressure	121 psi (8.7 kg/cm <sup>2</sup> )
Maximum System Voltage	48 VDC
Maximum Main Relief Hyd. Pressure	2500 psi. (172.3 bars)

## SECTION 6 - GENERAL SPECIFICATIONS & OPERATOR MAINTENANCE

**Table 6-3. Operating specifications - E300AJP**

Capacity: Unrestricted:	500 lbs. (227 kg)
Maximum Travel Grade, stowed Position (Gradeability) see Figure 4-3.	25%
Maximum Travel Grade, stowed Position (Side Slope) see Figure 4-3.	5%
Vertical Platform Height	30 ft. (9.14 m)
Horizontal Platform Reach (Up & Over)	20 ft. (6.1 m)
Machine Width	4 ft. (1.22 m)
Turning Radius (Outside)	10 ft. (3.05 m)
Turning Radius (Inside)	5 ft. (1.52 m)
Drive Speed (High Drive) (Above Horz.)	45-50 sec/ 200ft. (61 m) 55-68 sec/ 50 ft. (15.2 m)
Gross Machine Weight	15,800 lbs. (7167 kg)
Ground Bearing Pressure	130 psi (9.1 kg/cm <sup>2</sup> )
Maximum System Voltage	48 VDC

**Table 6-3. Operating specifications - E300AJP**

Maximum Main Relief Hyd. Pressure	3200 psi. (220.6 bars)
-----------------------------------	------------------------

### Capacities

**Table 6-4. Capacities**

Hydraulic Oil Tank	3.0 gallons (11.35 liters)
Hydraulic System (Including Tank)	4.0 gallons (15.14 liters)
Torque Hub, Drive*	17 ounces (0.50 L)
*Torque hubs should be one half full of lubricant.	

**Dimensional Data**

**Table 6-5. Dimensional Data**

Turning Radius (Inside)	5 ft. (1.52 m.)
Turning Radius (Outside)	10 ft. - 0 in. (3.05 m)
Machine Height (stowed)	6 ft., 7.0 in. (2.0 m.)
Machine Length (stowed) E300A E300AJ/AJP	17 ft., 2 in. (5.23 m.) 18 ft., (5.48 m)
Up and Over Platform Height	13 ft., 1.0 in. (3.99 m.).
Horizontal Reach Up and Over	20 ft. (6.1 m.).
Machine Width	4 ft., (1.22 m.)
Wheel Base	6 ft., 7.25 in. (2.01 m.)
Platform Height	30 ft., 0 in. (9.14 m.)

**Hydraulic Oil**

**Table 6-6. Hydraulic Oil**

Hydraulic System Operating Temperature Range	S.A.E. Viscosity Grade
+0° to + 180° F (-18° to +83° C)	10W
+0° to + 210° F (-18° to +99° C)	10W-20, 10W30
+50° to + 210° F (+10° to +99° C)	20W-20

**NOTE:** Hydraulic oils require anti-wear qualities at least API Service Classification GL-3, and sufficient chemical stability for mobile hydraulic system service.

**NOTE:** Machines may be equipped with Mobil EAL224H biodegradable and non-toxic hydraulic oil. This is vegetable oil based and possesses the same antiwear and rust protection characteristics as mineral oils, but will not adversely affect the ground water or the environment when spilled or leaked in small amounts. Mobil EAL224H has a viscosity of 34 cSt at 40° C. and viscosity index of 213. The operating temperature range of this oil is -18° C. to +83° C.

## SECTION 6 - GENERAL SPECIFICATIONS & OPERATOR MAINTENANCE

**NOTE:** Aside from JLG recommendations, it is not advisable to mix oils of different brands or types, as they may not contain the same required additives or be of comparable viscosities. If use of hydraulic oil other than Mobil DTE 11M is desired, contact JLG Industries for proper recommendations.

**Table 6-7. Mobil DTE 11M Specs**

ISO Viscosity Grade	#15
Gravity API	31.9
Pour Point, Max	-40 F (-40 C)
Flash Point, Min.	330 F (166 C)
Viscosity	
at 40° C	15 cSt
at 100° C	4.1 cSt
at 100° F	80 SUS
at 210° F	43 SUS
cp at -30° F	3.200
Viscosity Index	140

**NOTE:** Machines Manufactured before S/N 03000046376 were filled with Mobilfluid 424 hydraulic oil. If desired to change to Mobil DTE 11M hydraulic oil, the telescope seals are recommended to be changed. These are included in (JLG) kit P/N 8457399. Also included in the kit, is a decal to be located on the hydraulic tank to identify Mobil DTE 11M oil in use.

**Table 6-8. Mobilfluid 424 Specs**

SAE Grade	10W30
Gravity, API	29.0
Density, Lb/Gal. 60°F	7.35
Pour Point, Max	-46°F (-43°C)
Flash Point, Min.	442°F (228°C)
Viscosity	
Brookfield, cP at -18°C	2700
at 40° C	55 cSt
at 100° C	9.3 cSt
Viscosity Index	152

## SECTION 6 - GENERAL SPECIFICATIONS & OPERATOR MAINTENANCE

Table 6-9. Mobil EAL 224H Specs

Type	Synthetic Biodegradable
ISO Viscosity Grade	32/46
Specific Gravity	.922
Pour Point, Max	-25°F (-32°C)
Flash Point, Min.	428°F (220°C)
Operating Temp.	0 to 180°F (-17 to 162°C)
Weight	<b>7.64 lb. per gal. (0.9 kg per liter)</b>
Viscosity	
at 40° C	37 cSt
at 100° C	8.4 cSt
Viscosity Index	213
<b>NOTE:</b> Must be stored above 32°F (0°C)	

## Critical Stability Weights

### **WARNING**

**DO NOT REPLACE ITEMS CRITICAL TO STABILITY WITH ITEMS OF DIFFERENT WEIGHT OR SPECIFICATION (FOR EXAMPLE: BATTERIES, FILLED TIRES, PLATFORM) DO NOT MODIFY UNIT IN ANY WAY TO AFFECT STABILITY.**

Table 6-10. Critical Stability Weights

Components	LBS.	KG.
Counterweight	5300	2404.1
Tire and Wheel	120	54.4
Tire and Wheel (CSA)	262	119
Platform	135	61.2
Battery (each)	122	55.3

## Serial Number Locations

A serial number plate is affixed to the turntable, on the front of the left battery box support plate. If the serial number plate is damaged or missing, the machine serial number is stamped on the top right front of the frame.



## SECTION 6 - GENERAL SPECIFICATIONS & OPERATOR MAINTENANCE

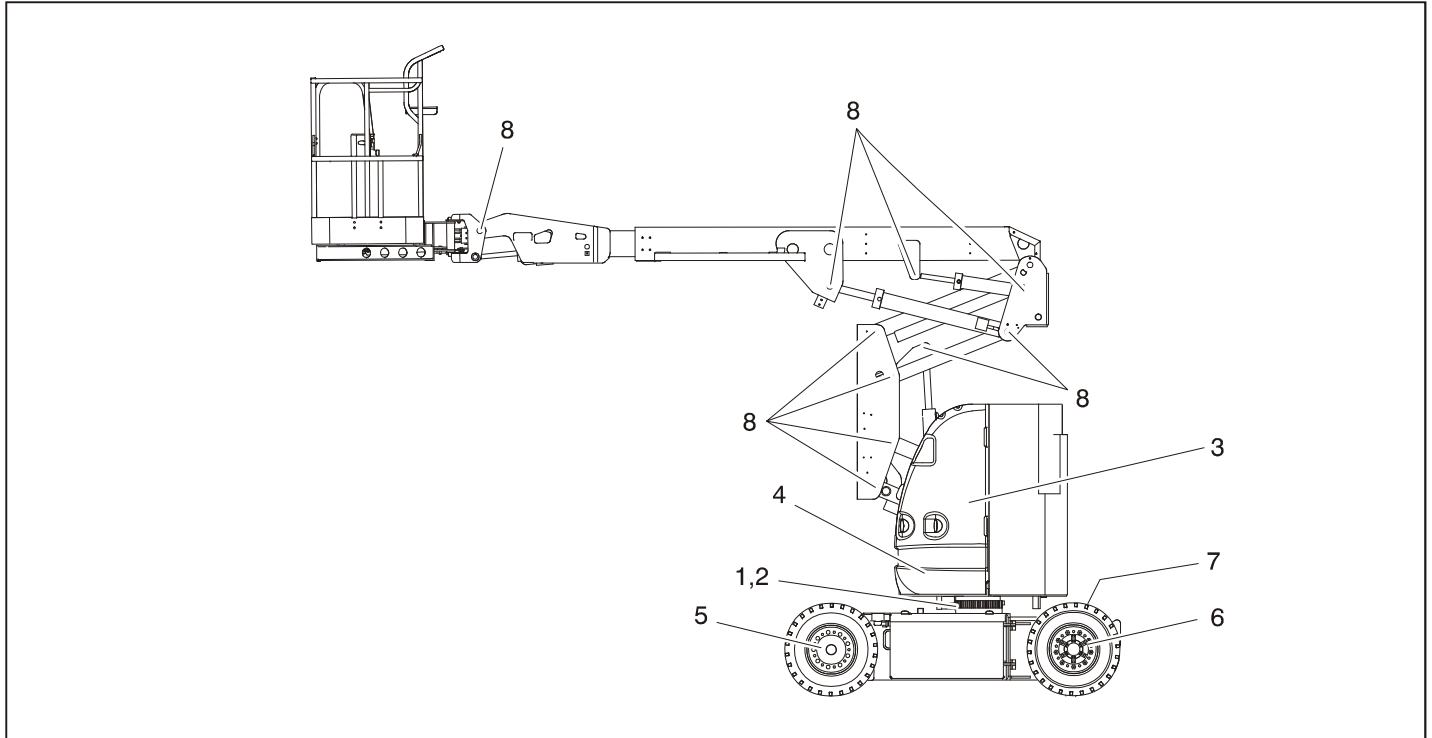

Figure 6-1. Operator Maintenance & Lubrication Diagram

## SECTION 6 - GENERAL SPECIFICATIONS & OPERATOR MAINTENANCE

### 6.3 OPERATOR MAINTENANCE

**NOTE:** The following numbers correspond to those in Figure 6-1., Operator Maintenance & Lubrication Diagram.

**Table 6-11. Lubrication Specifications.**

KEY	SPECIFICATIONS
MPG	Multipurpose Grease having a minimum dripping point of 350 degrees F. Excellent water resistance and adhesive qualities; and being of extreme pressure type (Timken OK 40 pounds minimum).
EPGL	Extreme Pressure Gear Lube (oil) meeting API Service Classification GL-5 or Mil-Spec Mil-L-2105.
HO	Hydraulic Oil. Mobil DTE-11M
OG*	Open Gear Lube - Tribol Molub-Alloy 936 Open Gear Compound. (JLG Part No. 3020027)
BG*	Bearing Grease (JLG Part No. 3020029) Mobilith SHA 460.
LL	Synthetic Lithium Lubricant, Gredag 741 Grease. (JLG Part No. 3020022)
EO	Engine (crankcase) Oil. Gas - API SF/SG class, MIL-L-2104. Diesel - API CC/CD class, MIL-L-2104B/MIL-L-2104C.
*MPG may be substituted for these lubricants, if necessary, but service intervals will be reduced.	

**NOTE:** It is recommended as a good practice to replace all filters at the same time.

#### **NOTICE**

**LUBRICATION INTERVALS ARE BASED ON MACHINE OPERATION UNDER NORMAL CONDITIONS. FOR MACHINES USED IN MULTI-SHIFT OPERATIONS AND/OR EXPOSED TO HOSTILE ENVIRONMENTS OR CONDITIONS, LUBRICATION FREQUENCIES MUST BE INCREASED ACCORDINGLY.**

#### 1. Swing Bearing

Lube Point(s) - 2 Grease Fittings

Capacity - A/R

Lube - MPG

Interval - Every 3 months or 150 hrs of operation

## SECTION 6 - GENERAL SPECIFICATIONS & OPERATOR MAINTENANCE

### 2. Swing Bearing/Worm Gear Teeth

Lube Point(s) - 2 Grease Fittings

Capacity - Spray On

Lube - Mobilac375NC

Interval - A/R

Comments - If necessary install grease fittings into worm gear housing and grease bearings.



**DO NOT OVERGREASE BEARINGS. OVERGREASING BEARINGS WILL RESULT IN DAMAGE TO OUTER SEAL IN HOUSING.**

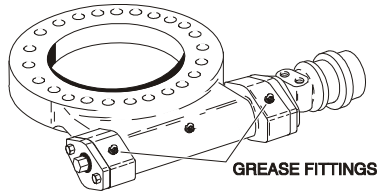

### 3. Hydraulic Tank

Lube Point(s) - Fill Cap

Capacity - 4 Gal. (15.1 L)

Lube - HO

Interval - Check Level daily; Change every 2 years or 1200 hours of operation.

Comments - On new machines, those recently overhauled, or after changing hydraulic oil, operate all systems a minimum of two complete cycles and recheck oil level in reservoir.

### 4. Hydraulic Return Filter

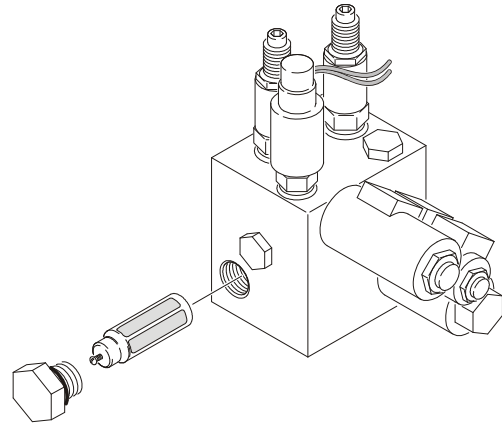

Interval - Change after first 50 hrs. and every 6 months or 300 hrs. thereafter.

Comments - Under certain conditions, it may be necessary to replace the hydraulic filter on a more frequent basis. A common symptom of a dirty filter is sluggishness experienced in hydraulic functions.

## SECTION 6 - GENERAL SPECIFICATIONS & OPERATOR MAINTENANCE

---

### 5. Wheel Drive Hub

Lube Point(s) - Level/Fill Plug

Capacity - 17 oz. (1/2 Full)

Lube - EPGL

Interval - Check level every 3 months or 150 hrs of operation; change every 2 years or 1200 hours of operation

### 6. Wheel Bearings

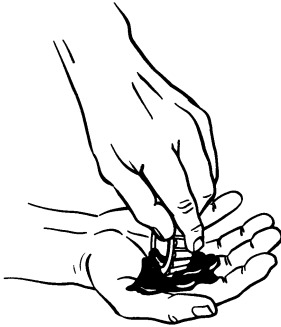

Lube Point(s) - Repack

Capacity - A/R

Lube - MPG

Interval - Every 2 years or 1200 hours of operation

### 7. Spindles/Bushing

Capacity - A/R

Lube - Lithium Lubricant

Interval - Every 2 years or 1200 hours of operation

Comments - At Spindle/Bushing Replacement; Coat I.D. of bushings prior to installing king pins.

### 8. Boom Pivot Pins/Bushing

Capacity - A/R

Lube - Lithium Lubricant

Interval - Every 2 years or 1200 hours of operation

Comments - At boom pivot pins/bushing replacement; Coat I.D. of bushings prior to installing pivot pins.

## 6.4 BATTERY MAINTENANCE AND CHARGING

### WARNING

TO AVOID INJURY FROM AN EXPLOSION, DO NOT SMOKE OR ALLOW SPARKS OR A FLAME NEAR BATTERY DURING SERVICING. ALWAYS WEAR EYE AND HAND PROTECTION WHEN SERVICING BATTERIES.

### Battery Maintenance, Quarterly

1. Open battery compartment cover to allow access to battery terminals and vent caps.

### CAUTION

WHEN ADDING WATER TO BATTERIES, ADD WATER UNTIL ELECTROLYTE COVERS PLATES. DO NOT CHARGE BATTERIES UNLESS ELECTROLYTE COVERS THE PLATES.

**NOTE:** *When adding distilled water to batteries, non-metallic containers and/or funnels must be used.*

*To avoid electrolyte overflow, add distilled water to batteries after charging.*

*When adding water to the battery, fill only to level indicated or 3/8" above separators.*

2. Remove all vent caps and inspect electrolyte level of each cell. Electrolyte level should be to the ring approximately one inch from top of battery. Fill batteries with distilled water only. Replace and secure all vent caps.
3. Remove battery cables from each battery post one at a time, negative first. Clean cables with acid neutralizing solution (e.g. baking soda and water or ammonia) and wire brush. Replace cables and/or cable clamp bolts as required.
4. Clean battery post with wire brush then re-connect cable to post. Coat non-contact surfaces with mineral grease or petroleum jelly.
5. When all cables and terminal posts have been cleaned, ensure all cables are properly positioned and do not get pinched. Close battery compartment cover.
6. Start hydraulic system and ensure that it functions properly.

## SECTION 6 - GENERAL SPECIFICATIONS & OPERATOR MAINTENANCE

---

### Battery Charging, Daily

**NOTE:** To avoid excessive battery charging time, do not allow batteries to become completely discharged.

To avoid electrolyte overflow, add distilled water to batteries after charging.

When adding water to the battery, fill only to level indicated or 3/8" above separators.

1. Charge batteries at the end of each work day, or when machine performance is significantly reduced due to batteries becoming discharged.
2. Charge batteries in accordance with the following procedure:
  - a. Open battery compartment, and battery charger compartment covers.

#### **WARNING**

**WHEN BATTERY CHARGER IS TO BE USED, CHARGING HARNESS MUST BE PLUGGED INTO A GROUNDED RECEPTACLE. IF RECEPTACLE IS NOT GROUNDED AND A MALFUNCTION SHOULD OCCUR, THE MACHINE COULD CAUSE SERIOUS ELECTRICAL SHOCK.**

- b. Remove charging harness cable and connect to a receptacle or the correct voltage.
- c. Allow batteries to charge until 100% LED is illuminated.

**NOTE:** When batteries are completely charged, disconnect charging harness cable from receptacle. Store charging harness cable.

- d. Ensure battery cables are positioned and are not pinched. Close and secure all compartment doors.

### 6.5 TIRES AND WHEELS

#### Tire Wear and Damage

Inspect tires periodically for wear or damage. Tires with worn edges or distorted profiles require replacement. Tires with significant damage in the tread area or side wall, require immediate evaluation before replacing the machine into service.

#### Wheel and Tire Replacement

Replacement wheels must have the same diameter and profile as the original. Replacement tires must be the same size and rating as the tire being replaced.

#### Wheel Installation

It is extremely important to apply and maintain proper wheel mounting torque.

#### **⚠ WARNING**

**WHEEL NUTS MUST BE INSTALLED AND MAINTAINED AT THE PROPER TORQUE TO PREVENT LOOSE WHEELS, BROKEN STUDS, AND POSSIBLE SEPARATION OF WHEEL FROM THE AXLE. BE SURE TO USE ONLY THE NUTS MATCHED TO THE CONE ANGLE OF THE WHEEL.**

Tighten the lug nuts to the proper torque to prevent wheels from coming loose. Use a torque wrench to tighten the fasteners. If you do not have a torque wrench, tighten the fasteners with a lug wrench, then immediately have a service garage or dealer tighten the lug nuts to the proper torque. Over-tightening will result in breaking the studs or permanently deforming the mounting stud holes in the wheels. The proper procedure for attaching wheels is as follows:

1. Start all nuts by hand to prevent cross threading. DO NOT use a lubricant on threads or nuts.
2. Tighten nuts in the following sequence.

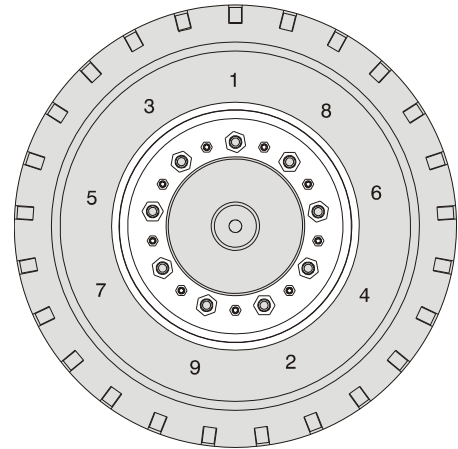

- The tightening of the nuts should be done in stages. Following the recommended sequence, tighten nuts per wheel torque.

**Table 6-12. Wheel Torque Chart**

TORQUE SEQUENCE		
1st Stage	2nd Stage	3rd Stage
40 ft lbs (55 Nm)	95 ft lbs (130 Nm)	170 ft lbs (230 Nm)

- Wheel nuts should be torqued after first 50 hours of operation and after each wheel removal. Check the torque after the first 10 miles, 25 miles, and again at 50 miles. Check periodically thereafter.

### 6.6 SUPPLEMENTAL INFORMATION

The following information is provided in accordance with the requirements of the European Machinery Directive 2006/42/EC and is only applicable to CE machines.

For electric powered machines, the equivalent continuous A-Weighted sound pressure level at the work platform is less than 70dB(A)

For combustion engine powered machines, guaranteed Sound Power Level (LWA) per European Directive 2000/14/EC (Noise Emission in the Environment by Equipment for Use Outdoors) based on test methods in accordance with Annex III, Part B, Method 1 and 0 of the directive, is 104 dB.

The vibration total value to which the hand-arm system is subjected does not exceed  $2,5 \text{ m/s}^2$ . The highest root mean square value of weighted acceleration to which the whole body is subjected does not exceed  $0,5 \text{ m/s}^2$ .



**SECTION 7. INSPECTION AND REPAIR LOG**

Machine Serial Number \_\_\_\_\_

**Table 7-1. Inspection and Repair Log**

<b>Date</b>	<b>Comments</b>

## SECTION 7 - INSPECTION AND REPAIR LOG

---

Table 7-1. Inspection and Repair Log

Date	Comments



## **WARNING:**



**The engine exhaust from this product contains chemicals known to the State of California to cause cancer, birth defects, or other reproductive harm.**

1702961

## **PROPOSITION 65 WARNING**

- **Battery posts, terminals and related accessories contain lead and lead compounds, chemicals known to the State of California to cause cancer and reproductive harm.**
- **Batteries also contain other chemicals known to the State of California to cause cancer.**
- **Wash hands after handling.**



An Oshkosh Corporation Company

Corporate Office  
JLG Industries, Inc.  
1 JLG Drive  
McConnellsburg PA. 17233-9533  
USA

(717) 485-5161

(717) 485-6417



3121214

## JLG Worldwide Locations

JLG Industries (Australia)

P.O. Box 5119  
11 Bolwarra Road  
Port Macquarie  
N.S.W. 2444  
Australia

+61 2 65 811111

+61 2 65 810122

JLG Latino Americana Ltda.

Rua Eng. Carlos Stevenson,  
80-Suite 71  
13092-310 Campinas-SP  
Brazil

+55 19 3295 0407

+55 19 3295 1025

JLG Industries (UK) Ltd

Bentley House  
Bentley Avenue  
Middleton  
Greater Manchester  
M24 2GP - England

+44 (0)161 654 1000

+44 (0)161 654 1001

JLG France SAS

Z.I. de Baulieu  
47400 Fauillet  
France

+33 (0)5 53 88 31 70

+33 (0)5 53 88 31 79

JLG Deutschland GmbH

Max-Planck-Str. 21  
D - 27721 Ritterhude - Ihlpohl  
Germany

+49 (0)421 69 350 20

+49 (0)421 69 350 45

JLG Equipment Services Ltd.

Rm 1107 Landmark North  
39 Lung Sum Avenue  
Sheung Shui N. T.  
Hong Kong

(852) 2639 5783

(852) 2639 5797

JLG Industries (Italia) s.r.l.

Via Po. 22  
20010 Pregnana Milanese - MI  
Italy

+39 029 359 5210

+39 029 359 5845

Oshkosh-JLG Singapore Technology

Equipment Pte Ltd  
29 Tuas Ave 4,  
Jurong Industrial Estate  
Singapore, 639379

+65-6591 9030



JLG Polska

Ul. Krolewska  
00-060 Warszawa  
Poland

+48 (0)914 320 245

+48 (0)914 358 200

JLG Industries (Scotland)

Wright Business Centre  
1 Lonmay Road  
Queenslie, Glasgow G33 4EL  
Scotland

+44 (0)141 781 6700

+44 (0)141 773 1907

Plataformas Elevadoras

JLG Iberica, S.L.  
Trapadella, 2  
P.I. Castellbisbal Sur  
08755 Castellbisbal, Barcelona  
Spain

+34 93 772 4700

+34 93 771 1762

JLG Sverige AB

Enkopingsvagen 150  
Box 704  
SE - 176 27 Jarfalla  
Sweden

+46 (0)850 659 500

+46 (0)850 659 534