



---

# Illustrated Parts Manual

**Models**  
**60H**  
**60H+6**  
**70H**

P/N  
3120290

*February 3, 2012*

**ANSI**



An Oshkosh Corporation Company



# REVISION LOG

August 1985 - Original Issue Of Manual

January 1988 - Revised

June 1994 - Revised (New Format)

December 1994 - Change 1

## Pages Affected:

Cover

Revision Log - Page 1

Table of Contents - Page 1

Section 1 - Pages 1-7, 1-9, 1-14, 1-17, 1-63, 1-71 & 1-72

Section 2 - Pages 2-1, 2-25 to 2-29, 2-32 to 2-35B, 2-38, 2-51, 2-78, 2-83, 2-92, 2-94 to 2-96, 2-98 to 2-103, 2-135, 2-141, 2-151 to 2-157, 1-160 & 1-161

Section 3 - Pages 3-8 & 3-9

Section 4 - Pages 4-4, 4-5, 4-7, 4-13, 4-17 to 4-21, 4-23 to 4-26, 4-29 to 4-31, 4-37, 4-39 & 4-41 to 4-47

Section 5 - Page 5-2

Section 6 - Page 6-3

Section 7 - Pages 7-2, 7-4 to 7-10, 7-18, 7-19, 7-22 & 7-23

Section 8 - Page 8-7

Section 9 - Pages 9-2 & 9-3

Section 10 - Pages 10-1 to 10-4

May 1995 - Revised

June 11, 2003 - Revised

July 31, 2006 - Revised

March 9, 2009 - Revised

February 3, 2012 - Revised

# REVISION LOG

# TABLE OF CONTENTS

FIGURE NO.	TITLE	PAGE NO.
<b>SECTION 1 - FRAME</b>		<b>1-1</b>
1-1	FRAME & STEERING INSTALLATIONS - 2WD	1-2
1-2	FRAME & STEERING INSTALLATIONS - 4WD	1-8
1-3	OPTIONAL REAR STEER INSTALLATION	1-14
1-4	TIRE AND WHEEL DRIVE INSTALLATIONS	1-16
1-5	DRIVE MOTOR ASSEMBLY - CESSNA (Single Speed)	1-24
1-6	DRIVE MOTOR ASSEMBLY - CESSNA (Two Speed)	1-26
1-7	DRIVE MOTOR ASSEMBLY - VICKERS (4WD Front)	1-30
1-8	DRIVE MOTOR ASSEMBLY - VICKERS (2WD & 4WD Rear)	1-32
1-9	DRIVE MOTOR ASSEMBLY - REXROTH	1-36
1-10	BRAKE ASSEMBLY - AUSCO & MICO	1-38
1-11	BRAKE ASSEMBLY - AUSCO 29479 (4WD Front)	1-42
1-12	BRAKE ASSEMBLY - AUSCO 37845 (4WD Front)	1-44
1-13	BRAKE ASSEMBLY - AUSCO (2WD Rear)	1-46
1-14	BRAKE ASSEMBLY - MICO	1-48
1-15	GEAR REDUCER ASSEMBLY (2WD Rear)	1-52
1-16	HUB ASSEMBLIES	1-54
1-17	VALVES INSTALLATION (Frame Mounted)	1-58
1-18	LOCKOUT VALVE ASSEMBLY	1-62
1-19	CONTROL VALVE ASSEMBLY - 2 SECTION BANG-BANG (4WS)	1-64
1-20	TOW PACKAGE INSTALLATIONS	1-66
<b>SECTION 2 - TURNTABLE</b>		<b>2-1</b>
2-1	BOOM, TURNTABLE AND BEARING LUBE INSTALLATIONS	2-4
2-2	CONTROL VALVE INSTALLATION - RACINE PROPORTIONAL	2-8
2-3	RACINE PROPORTIONAL CONTROL VALVE ASSEMBLY - OUTLET SECTION	2-14
2-4	RACINE PROPORTIONAL CONTROL VALVE ASSEMBLY	2-16
2-5	RACINE PROPORTIONAL CONTROL VALVE ASSEMBLY - INLET (DUMP) SECTION	2-18
2-6	RACINE PROPORTIONAL CONTROL VALVE ASSEMBLY - SERVO SECTION	2-22
2-7	CONTROL VALVE INSTALLATION - VICKERS PROPORTIONAL	2-26
2-8	VICKERS PROPORTIONAL CONTROL VALVE ASSEMBLY (Prior to October 1994)	2-34
2-9	VICKERS PROPORTIONAL CONTROL VALVE ASSEMBLY (Standard Controls) (October 1994 to Present)	2-38
2-10	VICKERS PROPORTIONAL CONTROL VALVE ASSEMBLY (Hydraulic Controls) (October 1994 to Present)	2-42
2-11	CONTROL VALVE ASSEMBLY - BANG-BANG WITH DUMP SECTION	2-46
2-12	CONTROL VALVE ASSEMBLY - BANG-BANG WITH DUMP SECTION	2-50
2-13	CONTROL VALVE ASSEMBLY - BANG-BANG WITH INLET RELIEF	2-54
2-14	CONTROL VALVE ASSEMBLY - 1 SECTION BANG-BANG (4WS Only)	2-58
2-15	STEERING VALVE ASSEMBLY	2-60
2-16	ACCESSORY VALVE ASSEMBLY (MILLER)	2-62
2-17	ACCESSORY VALVE ASSEMBLY (HYDRAFORCE)	2-64
2-18	SWING DRIVE, BEARING AND LOCK INSTALLATIONS	2-66
2-19	SWING MOTOR ASSEMBLY	2-70
2-20	SWING BRAKE ASSEMBLY (Prior to April 1992)	2-72
2-21	SWING BRAKE ASSEMBLY (April 1992 to Present)	2-76
2-22	SWING HUB ASSEMBLY	2-80
2-23	ROTARY COUPLING AND COLLECTOR RING ASSEMBLY AND INSTALLATION	2-82

# TABLE OF CONTENTS

FIGURE NO.	TITLE	PAGE NO.
<b>SECTION 2 - TURNTABLE (CONTINUED) . . . . . 2-1</b>		
2-24	DEUTZ ENGINE INSTALLATION WITHOUT NOISE REDUCTION (Built Prior to December 1992) . . . . .	2-86
2-25	DEUTZ ENGINE INSTALLATION WITH NOISE REDUCTION (Built December 1992 to Present) . . . . .	2-96
2-26	ADECO THROTTLE COMPONENTS INSTALLATION - DEUTZ ENGINE MACHINES . . . . .	2-104
2-27	GENERATOR INSTALLATION - DEUTZ ENGINE MACHINES . . . . .	2-108
2-28	FORD LSG-423 ENGINE INSTALLATIONS (Prior to February 1995) . . . . .	2-112
2-29	ADECO THROTTLE INSTALLATION - FORD ENGINE (Machines Built Prior to Mid 1987) . . . . .	2-124
2-30	PRECISION GOVERNOR INSTALLATION - FORD ENGINE (Machines Built Mid 1987 to February 1995) . . . . .	2-128
2-31	GENERATOR INSTALLATION - FORD ENGINE (Machines Built Prior to February 1995) . . . . .	2-130
2-32	FORD LRG423/LRG425 ENGINE INSTALLATION (February 1995 to Present) . . . . .	2-134
2-33	110 VOLT GENERATOR INSTALLATION - FORD (Machines Built February 1995 to Present) (Optional) . . . . .	2-142
2-34	DUAL FUEL INSTALLATION - FORD ENGINE MACHINES . . . . .	2-146
2-35	PUMP COUPLING INSTALLATIONS . . . . .	2-150
2-36	WISCONSIN ENGINE INSTALLATION . . . . .	2-154
2-37	MAIN PUMP ASSEMBLY (Machines With Racine Proportional Valves) . . . . .	2-160
2-38	MAIN PUMP ASSEMBLY (Machines With Vickers Proportional Valves Built Prior to Mid 1987 - Has One Outlet in End Cover) . . . . .	2-164
2-39	MAIN PUMP ASSEMBLY (Machines With Vickers Proportional Valves Mid 1987 to Present - Has Two Outlets in End Cover) . . . . .	2-166
2-40	TANKS INSTALLATION . . . . .	2-168
2-41	LP TANKS INSTALLATION . . . . .	2-174
2-42	GROUND CONTROL COMPONENTS INSTALLATION (Machines With Racine Proportional Valves) . . . . .	2-178
2-43	GROUND CONTROL COMPONENTS INSTALLATION (Machines With Vickers Proportional Valves) . . . . .	2-182
2-44	GROUND CONTROL COMPONENTS INSTALLATION (Machines With Hydraulic Controls) . . . . .	2-188
2-45	ELECTRICAL COMPONENTS INSTALLATION (Turntable Mounted) . . . . .	2-194
2-46	HOODS INSTALLATION (Machines Built Prior to December 1992) . . . . .	2-198
2-47	HOODS INSTALLATION (Machines Built December 1992 to Present) . . . . .	2-202
<b>SECTION 3 - BOOM . . . . . 3-1</b>		
3-1	BOOM COMPONENT ASSEMBLIES . . . . .	3-2
3-2	BOOM WIPERS INSTALLATION . . . . .	3-10
3-3	EXTEND-A-REACH INSTALLATIONS (60H+6 Machines) . . . . .	3-12
<b>SECTION 4 - PLATFORMS . . . . . 4-1</b>		
4-1	STANDARD PLATFORM AND FOOTSWITCH INSTALLATION . . . . .	4-2
4-2	LOW MOUNT PLATFORM AND FOOTSWITCH INSTALLATION . . . . .	4-8
4-3	ROTATOR MOTOR ASSEMBLY . . . . .	4-14
4-4	CONSOLE BOX ASSEMBLIES - PQ CONTROLLERS WITHOUT PROP TELE (Machines Built Prior to September 1991) . . . . .	4-16

# TABLE OF CONTENTS

FIGURE NO.	TITLE	PAGE NO.
4-5	CONSOLE BOX ASSEMBLIES - PQ CONTROLLERS WITH PROP TELE (Machines Built Prior to September 1991) . . . . .	4-20
4-6	CONSOLE BOX ASSEMBLY - PQ CONTROLLERS AND VICKERS PROP VALVE (Machines Built September 1991 to Present) . . . . .	4-24
4-7	CONSOLE BOX ASSEMBLY - OEM CONTROLLERS . . . . .	4-30
4-8	CONSOLE BOX ASSEMBLY - HYDRAULIC CONTROLLERS . . . . .	4-34
4-9	CAPACITY INDICATOR INSTALLATION (Optional) . . . . .	4-38
4-10	OPTIONAL COMMON PLATFORM MOUNTED COMPONENTS . . . . .	4-44
 <b>SECTION 5 - CYLINDER . . . . .</b>		<b>5-1</b>
5-1	AXLE EXTENSION CYLINDER ASSEMBLIES (Use With Optional Oscillating Axle) . . . . .	5-2
5-2	BOOM LIFT CYLINDER ASSEMBLIES . . . . .	5-6
5-3	EXTEND-A-REACH LIFT CYLINDER ASSEMBLY (60H+6 Only) . . . . .	5-10
5-4	MASTER CYLINDER ASSEMBLY . . . . .	5-12
5-5	PLATFORM LEVEL CYLINDER ASSEMBLIES (Model 60H & 70H Built Prior To December 1986) . . . . .	5-14
5-6	PLATFORM LEVEL CYLINDER ASSEMBLIES (Model 60H & 70H Built December 1986 to April 1992) . . . . .	5-16
5-7	PLATFORM LEVEL CYLINDER ASSEMBLIES (Model 60H & 70H Built April 1992 to Present)	5-18
5-8	SLAVE LEVEL CYLINDER ASSEMBLIES (Model 60H+6 Extend-A-Reach Prior to S/N 29914) . . . . .	5-20
5-9	SLAVE LEVEL CYLINDER ASSEMBLIES (Model 60H+6 Extend-A-Reach S/N 29914 to Present) . . . . .	5-22
5-10	STEER CYLINDER ASSEMBLIES . . . . .	5-24
5-11	TELESCOPE CYLINDER ASSEMBLY (Model 60H & 60H+6) . . . . .	5-28
5-12	TELESCOPE CYLINDER ASSEMBLY (Model 70H) . . . . .	5-30
5-13	CYLINDER BELLOWS INSTALLATION . . . . .	5-34
 <b>SECTION 6 - HYDRAULICS . . . . .</b>		<b>6-1</b>
6-1	HYDRAULIC DIAGRAM - AXLE LOCKOUT . . . . .	6-2
6-2	HYDRAULIC DIAGRAM - DRIVE (2WD) . . . . .	6-4
6-3	HYDRAULIC DIAGRAM - DRIVE (4WD) . . . . .	6-6
6-4	HYDRAULIC DIAGRAM - LEVEL (60H & 70H) (STANDARD PARTS) . . . . .	6-10
6-5	HYDRAULIC DIAGRAM - LEVEL (60H+6 WITH ROTATING PLATFORM) . . . . .	6-12
6-6	HYDRAULIC DIAGRAM - LIFT . . . . .	6-14
6-7	HYDRAULIC DIAGRAM - MANUAL DESCENT . . . . .	6-16
6-8	HYDRAULIC DIAGRAM - PUMP (STANDARD CONTROLS) . . . . .	6-18
6-9	HYDRAULIC DIAGRAM - PUMP (HYDRAULIC CONTROLS) . . . . .	6-22
6-10	HYDRAULIC DIAGRAM - ROTATE (STANDARD PARTS) . . . . .	6-26
6-11	HYDRAULIC DIAGRAM - SEQUENCE LINE . . . . .	6-28
6-12	HYDRAULIC DIAGRAM - STEER . . . . .	6-30
6-13	HYDRAULIC DIAGRAM - SWING . . . . .	6-32
6-14	HYDRAULIC DIAGRAM - TELESCOPE . . . . .	6-34
6-15	HYDRAULIC DIAGRAM LIST . . . . .	6-36

# TABLE OF CONTENTS

FIGURE NO.	TITLE	PAGE NO.
<b>SECTION 7 - ELECTRICAL</b>		<b>7-1</b>
7-1	ELECTRICAL DIAGRAM LIST	7-2
7-2	WIRING DIAGRAM - DUAL FUEL	7-13
7-3	WIRING DIAGRAM - GENERATOR (Deutz Engine)	7-14
7-4	WIRING DIAGRAM - GENERATOR (Ford Engine)	7-15
7-5	WIRING DIAGRAM - PLATFORM CONSOLE STANDARD CONTROLS	7-16
7-6	WIRING DIAGRAM - PLATFORM CONSOLE HYDRAULIC CONTROLS	7-19
7-7	WIRING DIAGRAM - STANDARD (Deutz Engine/Fixed Axle/Standard Controls)	7-20
7-8	WIRING DIAGRAM - STANDARD (Deutz Engine/Oscillating Axle/Standard Controls)	7-22
7-9	WIRING DIAGRAM - STANDARD (Deutz Engine/Hydraulic Controls)	7-24
7-10	WIRING DIAGRAM - STANDARD (Ford Engine/Hydraulic Controls)	7-26
<b>SECTION 8 - DECALS</b>		<b>8-1</b>
8-1	DECALS INSTALLATION - DOMESTIC BROWN	8-2
8-2	DECALS INSTALLATION - DOMESTIC BLACK	8-8
8-3	DECALS INSTALLATION - LATIN AMERICA	8-12
<b>SECTION 9 - RECOMMENDED SERVICE PARTS STOCK</b>		<b>9-1</b>
<b>SECTION 10 - SPECIAL OPTIONS</b>		<b>10-1</b>
10-1	SPECIAL OPTIONS LIST	10-1
10-2	EN280/CE/EURO/AUSTRALIAN SPECS COMPONENTS	10-6
10-3	JAPANESE/CHINESE SPECS COMPONENTS	10-9



# SECTION 1 FRAME

<b>TABLE OF CONTENTS</b>	
<b>FIGURE</b>	<b>DESCRIPTION</b>
1-1	FRAME & STEERING INSTALLATION - 2WD ..... 1-2
1-2	FRAME & STEERING INSTALLATION - 4WD ..... 1-8
1-3	OPTIONAL REAR STEER INSTALLATION ..... 1-14
1-4	TIRE & WHEEL DRIVE INSTALLATIONS. .... 1-16
1-5	DRIVE MOTOR ASSEMBLY - Cessna Single Speed ..... 1-24
1-6	DRIVE MOTOR ASSEMBLY - Cessna Two Speed ..... 1-26
1-7	DRIVE MOTOR ASSEMBLY - Vickers (4WD Front) ..... 1-30
1-8	DRIVE MOTOR ASSEMBLY - Vickers (2WD & 4WD Rear) ..... 1-32
1-9	DRIVE MOTOR ASSEMBLY - Rexroth ..... 1-36
1-10	BRAKE ASSEMBLY - Ausco & Mico (2WD & 4WD Rear With Cessna Motors) ..... 1-38
1-11	BRAKE ASSEMBLY - Ausco 29479 (4WD Front) ..... 1-42
1-12	BRAKE ASSEMBLY - Ausco 37845 (4WD Front) ..... 1-44
1-13	BRAKE ASSEMBLY - Ausco (2WD Rear) ..... 1-46
1-14	BRAKE ASSEMBLY - Mico ..... 1-48
1-15	GEAR REDUCER ASSEMBLY (2WD Rear) ..... 1-52
1-16	HUB ASSEMBLIES. .... 1-54
1-17	VALVES INSTALLATION (Frame Mounted) ..... 1-58
1-18	LOCKOUT VALVE ASSEMBLY ..... 1-62
1-19	CONTROL VALVE ASSEMBLY - 2 SECTION RACINE BANG-BANG (4WS) ..... 1-64
1-20	TOW PACKAGE INSTALLATION ..... 1-66

# SECTION 1 FRAME

FIGURE 1-1. FRAME AND STEERING INSTALLATION - 2WD

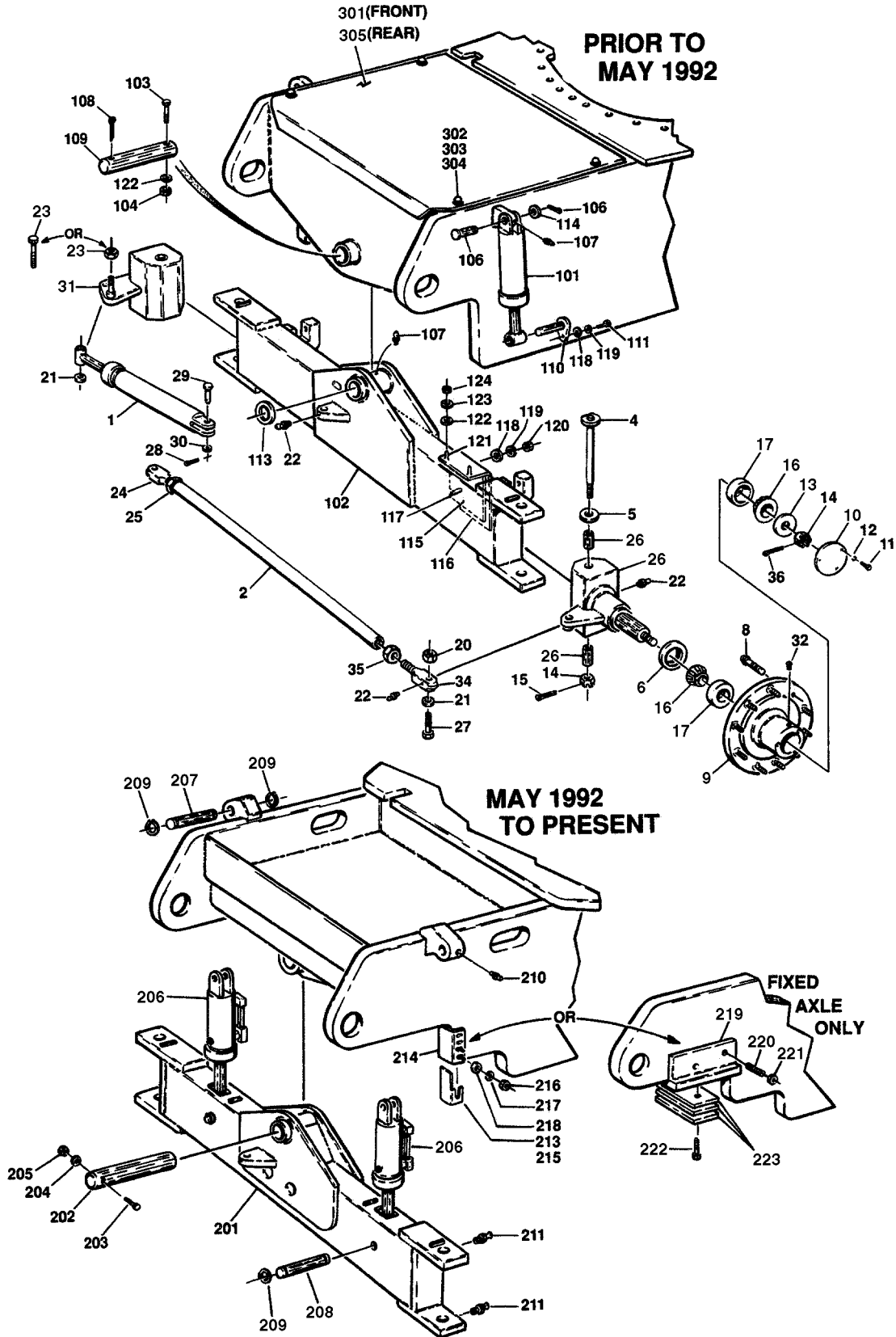

# SECTION 1 FRAME

**FIGURE 1-1. FRAME AND STEERING INSTALLATION - 2WD**

FIG & ITEM #	PART NUMBER	DESCRIPTION	QTY.	REV.
		<b>FRAME AND STEERING INSTALLATION - 2WD</b>	Ref.	
		<b>FRAME WELDMENT OPTIONS</b>	Ref.	
		60H and 60H+6 with Fixed Axle:	1	
	2360228	Machines with Racine Valves		
	2360251	Machines with Vickers Valves (Built Prior to May 1992)		
	2360279	Machines with Vickers Valves and Special Counterweight (Built Prior to May 1992)		
	2360344	Machines with Vickers Valves (Built May 1992 to Present)		
	2360345	Machines with Optional 4WS (Prior to June 1994)		
	2360382	Machines with Optional 4WS (June 1994 to Present)		
		70H With Fixed Axle:	1	
	2360247	Machines with Racine Valves		
	2360252	Machines with Vickers Valves (Domestic) (Built Prior to May 1992)		
	2360293	Machines with Vickers Valves (CSA) (Built Prior to May 1992)		
	2360344	Machines with Vickers Valves (Built May 1992 to Present)		
	2360345	Machines with Optional 4WS (Prior to June 1994)		
	2360382	Machines with Optional 4WS (June 1994 to Present)		
		60H and 60H+6 with Oscillating Axle:	1	
	2360181	Machines with Racine Valves		
	2360250	Machines with Vickers Valves (Built Prior to May 1992)		
	2360278	Machines with Vickers Valves and Special Counterweight (Domestic) (Built Prior to May 1992)		
	2360329	Machines with Vickers Valves and Special Counterweight (CS) (Built Prior to May 1992)		
	2360344	Machines with Vickers Valves (Built May 1992 to Present)		
	2360345	Machines with Optional 4WS (Prior to June 1994)		
	2360382	Machines with Optional 4WS (June 1994 to Present)		
		70H with Oscillating Axle:	1	
	2360242	Machines with Racine Valves and Ford Power		
	2360243	Machines with Racine Valves and Deutz Power		
	2360248	Machines with Vickers Valves and Ford Power (Built Prior to May 1992)		
	2360249	Machines with Vickers Valves and Deutz Power (Built Prior to May 1992)		
	2360344	Machines with Racine Valves (Built May 1992 to Present)		
	2360345	Machines with Optional 4WS (Prior to June 1994)		

# SECTION 1 FRAME

SECTION 1 FRAME

**FIGURE 1-1. FRAME AND STEERING INSTALLATION - 2WD (CONTINUED)**

FIG & ITEM #	PART NUMBER	DESCRIPTION	QTY.	REV.
	2360382	Machines with Optional 4WS (June 1994 to Present)		
	0236282	<b>STEERING AND SPINDLES INSTALLATION - 60H, 60H+6 AND 70H STANDARD MACHINES BUILT PRIOR TO MAY 1992</b>	Ref.	M
	0238261	<b>STEERING AND SPINDLES INSTALLATION - 60H WITH 750 LBS CAPACITY (DOMESTIC) AND 70H CSA MACHINES BUILT PRIOR TO MAY 1992</b>	Ref.	F
	0251485	<b>STEERING AND SPINDLES INSTALLATION - 60H CSA MACHINES BUILT PRIOR TO MAY 1992</b>	Ref.	D
	0252377	<b>STEERING AND SPINDLES INSTALLATION - 60H STANDARD MACHINES BUILT MAY 1992 TO PRESENT</b>	Ref.	-
	0252378	<b>STEERING AND SPINDLES INSTALLATION - 60H WITH 750 LBS. CAPACITY, 60H+6 AND 70H STANDARD MACHINES BUILT MAY 1992 TO PRESENT</b> <b>Note: Components for Machines with Towing Package may vary, see Towing Package Installation.</b>	Ref.	-
1	1681562	Steer Cylinder Assembly (See Section 5 for Breakdown)	1	
2	3840734	Tie-Rod (RH Thread - Both Ends - Used Prior to May 1986)	1	
	3840866	Tie-Rod (RH/LH Thread - Used May 1986 to Present)	1	
3	Not Used			
4	3421153	King-Pin	2	
5	0440161	Bearing, Thrust	4	
6		Seal, Hub Options:	2	
	3960098	Standard Machines		
	3960343	Machines With 750 Capacity		
7	3300007	Nut, Wheel 3/4"-16NF	20	
8	0630078	Stud, Wheel 3/4"-16NF x 2 1/4" (Part of Hub Assembly)	20	
9		Hub Assembly Options:	2	
	0235017	Standard Machines		
	2780109	Machines With 750 Capacity (Prior to May 1992)		
	2780188	Machines With 750 Capacity (May 1992 to Present)		
10		Cap, Hub Options:	2	
	1120032	Standard Machines		
	1120304	Machines With 750 Capacity		
11	0721003	Bolt #10-24NC x 3/8"	6	
12	4761000	Lockwasher #10	6	
13		Washer, Hardened Options:	2	
	4740016	Standard Machines		
	4740283	Machines With 750 Capacity		
14	3323403	Nut, Slotted 1 1/2"-12NF	4	
15	3451012	Pin, Cotter 5/16" x 3"	2	

# SECTION 1 FRAME

**FIGURE 1-1. FRAME AND STEERING INSTALLATION - 2WD (CONTINUED)**

FIG & ITEM #	PART NUMBER	DESCRIPTION	QTY.	REV.
16	0440019	Cone, Bearing Options: Standard Machines	4	
	0440171	Machines With 750 Capacity		
17	0440018	Cup, Bearing Options: Standard Machines	4	
	0440170	Machines With 750 Capacity		
18	Not Used			
19	Not Used			
20	3312602	Nut, Jam 1"-8NC	2	
21	0440091	Washer, Thrust	3	
22	2160002	Fitting, Grease	5	
23		Hardware Options:	1	
	3300175	Locknut (Prior to May 1992)		
	0642632	Bolt 1"-8NC x 4" (May 1992 to Present)		
24	0560605	Block, Tie-Rod (RH)	1	
25	3323002	Nut, Jam 1 1/4 - 12NF	1	
26		Spindle (LH) Options:	1	
	4130229	Standard Machine (Prior to May 1992)		
	4130235	Machines With 750 Capacity (Prior to May 1992)		
	4130250	CSA Machine (Prior to May 1992)		
	4130275	Standard Machine (May 1992 to Present)		
	4130278	Machines With 750 Capacity (May 1992 to Present)		
	0960523	Bushing, Bronze		
27	0642630	Bolt 1"-8NC x 3 3/4"	2	
28	3450606	Pin, Cotter 3/16" x 1 1/2"	1	
29	3431622	Pin, Clevis 1" x 2 3/4"	1	
30	4712600	Flatwasher 1" Narrow	1	
31		Spindle (RH) Options:	1	
	4130228	Standard Machine (Prior to May 1992)		
	4130234	Machines With 750 Capacity (Prior to May 1992)		
	4130249	CSA Machine (Prior to May 1992)		
	4130274	Standard Machine (May 1992 to Present)		
	4130277	Machines With 750 Capacity (May 1992 to Present)		
	0960523	Bushing, Bronze		
32	3520048	Plug, Tapered (Prior to November 1986 Only)	2	
33	0100011	Loctite #242 (Not Shown)	A/R	
34	0560605	Block, Tie-Rod (RH Thread) (Used Prior to May 1986)	1	
	0560714	Block, Tie-Rod (LH Thread) (Used May 1986 to Present)		
35	3323002	Nut, Jam 1 1/4"-12NF (RH Thread) (Used Prior to May 1986)	1	
	3300229	Nut, Jam 1 1/4" - 12NF (LH Thread) (Used May 1986 to Present)		
36	3450810	Pin, Cotter 1/4" x 2 1/2"	2	
	3451010	Pin, Cotter 5/16" x 2 1/2"		

# SECTION 1 FRAME

**FIGURE 1-1. FRAME AND STEERING INSTALLATION - 2WD (CONTINUED)**

FIG & ITEM #	PART NUMBER	DESCRIPTION	QTY.	REV.
	0236747	<b>OPTIONAL OSCILLATING AXLE INSTALLATION (MACHINES BUILT PRIOR TO MAY 1992)</b>	Ref.	E
101	1681569	Axle Lockout Cylinder Assembly (See Section for Breakdown)	2	
102	4842178	Front Axle Weldment	1	
	0980069	Bushing, Bronze	2	
103	0641838	Bolt 1/2"-13NC x 4 3/4"	1	
104	3311805	Locknut 1/2"-13NC	1	
105	3421220	Pin, Clevis	2	
106	3450607	Pin, Cotter 3/16" x 1 3/4"	4	
107	2160002	Fitting, Grease	6	
108	3451214	Pin, Cotter 3/8" x 3 1/2"	1	
109	3421273	Pin	1	
110	3421219	Pin Weldment	2	
111	0641606	Bolt 3/8"-16NC x 3/4"	2	
112	Not Used			
113	0440163	Bearing, Thrust	2	
114	4740110	Flatwasher	4	
115	4070539	Shim, Axle	A/R	
116	4220099	Stop, Axle	2	
117	4300034	Stud (Welded on Part)	4	
118	4751600	Flatwasher 3/8"	5	
119	4761600	Lockwasher 3/8"	6	
120	3311601	Nut 3/8"-16NC	4	
121	4300048	Stud (Welded on Part)	4	
122	4751800	Flatwasher 1/2"	5	
123	4761800	Lockwasher 1/2"	4	
124	3311801	Nut 1/2"-18NC	4	
	0252380	<b>FRONT AXLE INSTALLATION (FIXED AXLE MACHINES BUILT MAY 1992 TO PRESENT)</b>	Ref.	B
	0252381	<b>FRONT AXLE INSTALLATION (OSCILLATING AXLE MACHINES BUILT MAY 1992 TO PRESENT)</b> <b>Note: Components for Machines with Towing Pack- age may vary, see Towing Package Installation.</b>	Ref.	C
201	4844037	Axle Weldment	1	
	0961613	Bushing, Bronze	2	
	3780188	O-Ring	2	
202	3421995	Pin, Pivot	1	
203	0641832	Bolt 1/2"-18NC x 4"	1	
204	4761800	Lockwasher 1/2"	1	
205	3311801	Nut 1/2"-18NC	1	
		<b>Note: Items 206-209 Oscillating Axle Only.</b>		
206	1682688	Axle Lockout Cylinder Assembly (See Section 5 for Breakdown)	2	
207	3421996	Pin, Attach (Upper)	2	
208	3421997	Pin, Attach (Lower)	2	
209	3760133	Ring, Retaining	8	

# SECTION 1 FRAME

**FIGURE 1-1. FRAME AND STEERING INSTALLATION - 2WD (CONTINUED)**

FIG & ITEM #	PART NUMBER	DESCRIPTION	QTY.	REV.
210	2160002	Fitting, Grease (Straight)	A/R	
211	2160001	Fitting, Grease (90°)	4	
212	Not Used			
213	4070796	Shim, Axle (LH)	3	
214	3537016	Plate, Stop	2	
215	4070795	Shim, Axle (RH)	3	
216	3311501	Nut 5/16"-18NC	4	
217	4761500	Lockwasher 5/16"	4	
218	4751500	Flatwasher 5/16"	4	
<b>Note: Items 219-223 Fixed Axle Only.</b>				
219	4844258	Stop, Axle	2	
220	3951611	Setscrew 3/8"-16NC x 1 3/8"	4	
221	3311602	Nut, Jam 3/8"-16NC	4	
222	0641508	Bolt 5/16"-18NC x 1"	4	
223	4070812	Shim, Stop (1/16")	A/R	
	4070813	Shim, Stop (1/4")	A/R	
	4070814	Shim, Stop (1/8")	A/R	
	4070815	Shim, Stop (3/8")	A/R	
	0100011	Loctite #242	A/R	
	0236283	<b>FRAME SHIELDS INSTALLATION</b>	Ref.	
	0236732	<b>FRAME SHIELDS INSTALLATION</b>	Ref.	
	0238923	<b>FRAME SHIELDS INSTALLATION</b>	Ref.	
	0238924	<b>FRAME SHIELDS INSTALLATION</b>	Ref.	
	0252389	<b>FRAME SHIELDS INSTALLATION</b>	Ref.	
	0252390	<b>FRAME SHIELDS INSTALLATION</b>	Ref.	
301		Front Frame Shields Options:	1	
	4060573	Fixed Axle Machines Built Prior to May 1992		
	4060594	Oscillating Axle Machines Built Prior to April 1985		
	4060607	Oscillating Axle Machines Built April 1985 to May 1992		
	1670618	All Machines Built May 1992 to Present		
302	4761400	Lockwasher 1/4"	8	
303	3300151	Nut, Acorn 1/4"-20NC	8	
304	4300031	Stud (Welded on Part)	8	
305		Rear Frame Shield Options:	1	
	4060573	Fixed Axle Machines Built Prior to may 1992		
	4060573	Oscillating Axle Machines Built Prior to April 1985		
	4060606	Oscillating Axle Machines Built April 1985 to May 1992		
	1670619	4WS Machines Only Built May 1992 to Present		

# SECTION 1 FRAME

FIGURE 1-2. FRAME AND STEERING INSTALLATION - 4WD

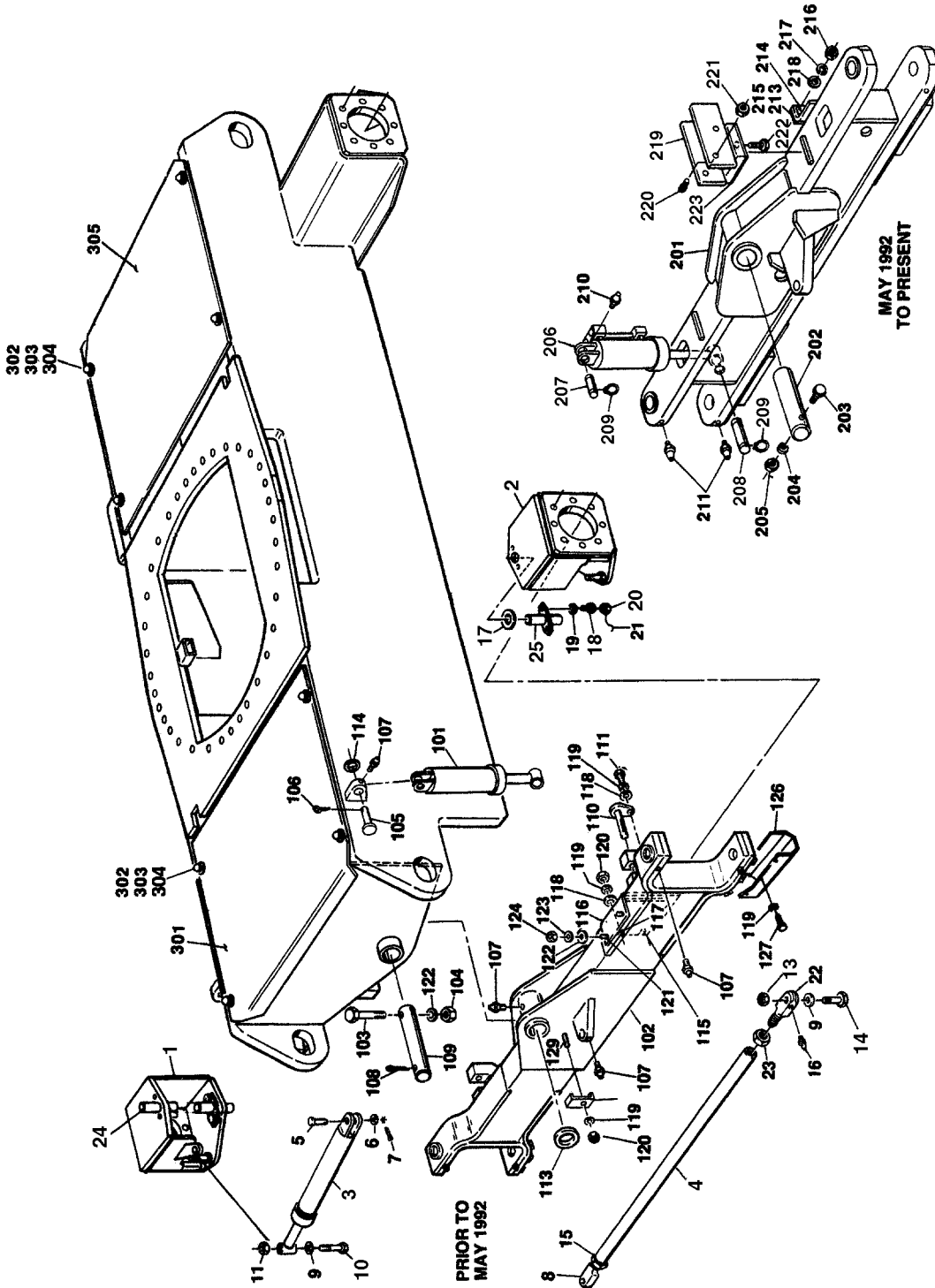

SECTION 1 FRAME



# SECTION 1 FRAME

**FIGURE 1-2. FRAME AND STEERING INSTALLATION - 4WD**

FIG & ITEM #	PART NUMBER	DESCRIPTION	QTY.	REV.
		<b>FRAME AND STEERING INSTALLATION - 4WD</b>	Ref.	
		<b>FRAME WELDMENT OPTIONS</b>	Ref.	
		60H and 60H+6 with Fixed Axle:	1	
	2360266	Machines with Racine Valves		
	2360269	Machines with Vickers Valves (Built Prior to May 1992)		
	2360324	Machines with Vickers Valves and 750 Lbs. Capacity (Built Prior to May 1992)		
	2360344	Machines with Vickers Valves (Built May 1992 to Present)		
		70H with Fixed Axle:	1	
	2360267	Machines with Racine Valves and Ford Power		
	2360268	Machines with Racine Valves and Deutz Power		
	2360270	Machines with Vickers Valves and Ford Power (Built Prior to May 1992)		
	2350271	Machines with Vickers Valves and Deutz Power (Built Prior to May 1992)		
	2360344	Machines with Vickers Valves (Built May 1992 to Present)		
	2360345	Machines with Optional 4WS (Prior to June 1994)		
	2360382	Machines with Optional 4WD (June 1994 to Present)		
		60H with Oscillating Axle:	1	
	2360181	Machines with Racine Valves		
	2360250	Machines with Vickers Valves (Built Prior to May 1992)		
	2360344	Machines with Vickers Valves (Built May 1992 to Present)		
	2360345	Machines with Optional 4WS (Prior to June 1994)		
	2360382	Machines with Optional 4WS (June 1994 to Present)		
		60+6 with Oscillating Axle:	1	
	2360285	Machines Built Prior to May 1992		
	2360344	Machines with 2WS Built May 1992 to Present		
	2360345	Machines with Optional 4WS Built May 1992 to June 1994		
	2360382	Machines with Optional 4WS (June 1994 to Present)		
		70H with Oscillating Axle:	1	
	2360242	Machines with Racine Valves and Ford Power		
	2360243	Machines with Racine Valves and Deutz Power		
	2360248	Machines with Vickers Valves and Ford Power (Built Prior to May 1992)		
	2360249	Machines with Vickers Valves and Deutz Power (Built Prior to May 1992)		

# SECTION 1 FRAME

**FIGURE 1-2. FRAME AND STEERING INSTALLATION - 4WD (CONTINUED)**

FIG & ITEM #	PART NUMBER	DESCRIPTION	QTY.	REV.
	2360344	Machines with Racine Valves (Built May 1992 to Present)		
	2360345	Machines with Optional 4WS (Prior to June 1994)		
	2360382	Machines with Optional 4WS (June 1994 to Present)		
		<b>STEERING AND SPINDLES INSTALLATIONS</b>		
	0236731	<b>STEERING AND SPINDLE INSTALLATION - DOMESTIC MACHINES WITH CESSNA MOTORS BUILT PRIOR TO MAY 1992</b>	Ref.	G
	0238309	<b>STEERING AND SPINDLE INSTALLATION - DOMESTIC MACHINES WITH VICKERS MOTORS BUILT PRIOR TO MAY 1992</b>	Ref.	G
	0251802	<b>STEERING AND SPINDLE INSTALLATION - CSA MACHINES BUILT PRIOR TO MAY 1992</b>	Ref.	C
	0252288	<b>STEERING AND SPINDLE INSTALLATION - MACHINES BUILT MAY 1992 TO PRESENT</b>	Ref.	A
		<b>Note: Components for Machines with Towing Package may vary, see Towing Package Installation.</b>		
1		Spindle (RH) Options:	1	
	4130153	Machines Built Prior to May 1992		
	4130272	Machines Built May 1992 to Present		
2		Spindle (LH) Options:	1	
	4130154	Machines Built Prior to May 1992		
	4130271	Machines Built May 1992 to Present		
3		Steer Cylinder Assembly Options (See Section 5 for Breakdown):	1	
	1682203	Machines Built Prior to May 1992		
	1681555	Machines Built May 1992 to Present		
4		Tie-Rod Options:	1	
	3840868	Machines Built Prior to May 1992		
	3841142	Machines Built May 1992 to Present		
5	3431622	Pin, Clevis	1	
6	4712600	Flatwasher 1" Narrow	1	
7	3450606	Pin, Cotter	1	
8	0560605	Block, Tie-Rod (RH)	1	
9	0440091	Bearing, Thrust	3	
10		Bolt Options:	1	
	0642634	Bolt 1"-8NC x 4 1/4" (Machines Built Prior to May 1992)		
	0630447	Bolt 1"-8NC x 5 3/4" (Machines Built May 1992 to Present)		
11	3312602	Nut, Jam 1"-8NC	1	
12	0100011	Loctite #242 (Not Shown)	A/R	
13		Locknut, Special Options:	2	
	3300175	Locknut, Special (Machines Built Prior to May 1992)		
	3312602	Nut, Jam (Machines Built May 1992 to Present)		

# SECTION 1 FRAME

**FIGURE 1-2. FRAME AND STEERING INSTALLATION - 4WD (CONTINUED)**

FIG & ITEM #	PART NUMBER	DESCRIPTION	QTY.	REV.
14	Not Required	Bolt, Special Options: Machines Built Prior to May 1992	2	
	0630425	Machines Built May 1992 to Present		
15	3323002	Nut, Jam (RH)	1	
16	2160002	Fitting, Grease	2	
17		Washer, Thrust Options:	A/R	
	4740082	Machines Built Prior to May 1992	4	
	4740391	Machines Built May 1992 to Present	2	
18		Bolt Options:	8	
	0641608	Bolt 3/8"-16NC x 1" (Machines Built Prior to May 1992)		
	0630083	Bolt, Special (Machines Built May 1992 to Present)		
19	4761600	Lockwasher 3/8"	8	
20		Clip, Retainer Options:	8	
	1380124	Machines Built Prior to May 1992		
	Not Required	Machines Built May 1992 to Present		
21	4920096	Wire, Safety	A/R	
22	0560714	Block, Tie-Rod (LH)	1	
23	3300229	Nut, Jam (LH)	1	
24		Kingpin (RH) Options:	2	
	3421199	Domestic Machines with Cessna Motor Built Prior to May 1992		
	3421462	Domestic Machines with Vickers Motor Built Prior to May 1992		
	3421883	CSA Machines Built Prior to May 1992		
	3422002	Machines Built May 1992 to Present		
25		Kingpin (LH) Options:	2	
	3421199	Domestic Machines with Cessna Motor Built Prior to May 1992		
	3421461	Domestic Machines with Vickers Motor Built Prior to May 1992		
	3421882	CSA Machines Built Prior to May 1992		
	3422002	Machines Built May 1992 to Present		
26	3780187	O-Ring (Not Shown) (June 1994 to Present)	8	
	0236739	<b>OPTIONAL OSCILLATING AXLE INSTALLATION (MACHINES BUILT PRIOR TO MAY 1992)</b>	Ref.	H
101	1681568	Axle Lockout Cylinder Assembly (See Section 5 for Breakdown)	2	
102	4842159	Front Axle Weldment	1	
	0961032	Bushing, Bronze (At Kingpin)	4	
	0980069	Bushing, Bronze (At Axle Pivot)	2	
103	0641838	Bolt 1/2"-13NC x 4 3/4"	1	
104	3311805	Locknut 1/2"-13NC	1	
105	3421220	Pin, Clevis	2	
106	3450607	Pin, Cotter 3/16" x 1 3/4"	4	
107	2160002	Fitting, Grease	10	
108	3451214	Pin, Cotter 3/8" x 3 1/2"	1	
109	3421273	Pin	1	
110	3421219	Pin Weldment	2	

# SECTION 1 FRAME

**FIGURE 1-2. FRAME AND STEERING INSTALLATION - 4WD (CONTINUED)**

FIG & ITEM #	PART NUMBER	DESCRIPTION	QTY.	REV.
111	0641606	Bolt 3/8"-16NC x 3/4"	2	
112	Not Used			
113	0440163	Bearing, Thrust	2	
114	4740040	Flatwasher	4	
115	4070573	Shim, Axle	A/R	
116	4220102	Stop, Axle (LH)	1	
117	4300034	Stud (Welded on Part)	4	
118	4751600	Flatwasher 3/8"	6	
119	4761600	Lockwasher 3/8"	19	
120	3311601	Nut 3/8"-16NC	5	
121	4300048	Stud (Welded on Part)	4	
122	4751800	Flatwasher 1/2"	5	
123	4761800	Lockwasher 1/2"	4	
124	3311801	Nut 1/2"-18NC	4	
125	4220103	Stop, Axle (RH)	1	
126	3530294	Plate, Protection	2	
127	3941608	Setscrew 3/8"-16NC x 1"	12	
128	1320125	Clamp, Hose	1	
129	4300030	Stud	1	
	0252273	<b>FRONT AXLE INSTALLATION (FIXED AXLE MACHINES BUILT MAY 1992 TO PRESENT)</b>	Ref.	C
	0252272	<b>FRONT AXLE INSTALLATION (OSCILLATING AXLE MACHINES BUILT MAY 1992 TO PRESENT)</b> <b>Note: Components for Machines with Towing Package may vary, see Towing Package Installation.</b>	Ref.	C
201		Axle Options:	1	
	4843985	Axle Weldment (May 1992 to June 1994)		
	4844807	Axle Weldment (June 1994 to Present)		
	0961613	Bushing, Bronze (Axle Pivot)	2	
	3780188	O-Ring (Axle Pivot)	2	
	0961614	Bushing, Bronze (Kingpin), (May 1992 to June 1994)	4	
	0961850	Bushing, Bronze (Kingpin), (June 1994 to Present)	4	
202	3421995	Pin, Pivot	1	
203	0641832	Bolt 1/2"-18NC x 4"	1	
204	4761800	Lockwasher 1/2"	1	
205	3311801	Nut 1/2"-18NC	1	
		<b>Note: Items 206-209 Oscillating Axle Only.</b>		
206	1682688	Axle Lockout Cylinder Assembly (See Section 5 for Breakdown)	2	
207	3421996	Pin, Attach (Upper)	2	
208	3421997	Pin, Attach (Lower)	2	
209	3760133	Ring, Retaining	8	
210	2160002	Fitting, Grease (Straight)	A/R	
211	2160001	Fitting, Grease (90°)	4	
212	Not Used			
213	4070796	Shim, Axle (LH)	3	
214	3537016	Plate, Stop	2	

# SECTION 1 FRAME

**FIGURE 1-2. FRAME AND STEERING INSTALLATION - 4WD (CONTINUED)**

FIG & ITEM #	PART NUMBER	DESCRIPTION	QTY.	REV.
215	4070795	Shim, Axle (RH)	3	
216	3311501	Nut 5/16"-18NC	4	
217	4761500	Lockwasher 5/16"	4	
218	4751500	Flatwasher 5/16"	4	
<b>Note: Items 219-223 Fixed Axle Only.</b>				
219	4844258	Stop, Axle	2	
220	3951611	Set Screw 3/8"-16NC x 1 3/8"	4	
221	3311602	Nut, Jam 3/8"-16NC	4	
222	0641508	Bolt 5/16"-18NC x 1"	4	
223	4070812	Shim, Stop (1/16")	A/R	
	4070813	Shim, Stop (1/4")	A/R	
	4070814	Shim, Stop (1/8")	A/R	
	4070815	Shim, Stop (3/8")	A/R	
	0100011	Loctite #242	A/R	
224	4640812	Valve, Relief (Not Shown - Located Near Kingpin) (June 1994 to Present)	4	
	0236283	<b>FRAME SHIELDS INSTALLATION</b>	Ref.	
	0236732	<b>FRAME SHIELDS INSTALLATION</b>	Ref.	
	0238923	<b>FRAME SHIELDS INSTALLATION</b>	Ref.	
	0238924	<b>FRAME SHIELDS INSTALLATION</b>	Ref.	
	0251525	<b>FRAME SHIELDS INSTALLATION</b>	Ref.	
	0252389	<b>FRAME SHIELDS INSTALLATION</b>	Ref.	
	0252390	<b>FRAME SHIELDS INSTALLATION</b>	Ref.	
301		Front Frame Shield Options:	1	
	4060606	Fixed Axle Machines Built Prior to May 1992		
	4060607	Oscillating Axle Machines built Prior to may 1992		
	1670618	All Machines Built May 1992 to Present		
302	4761400	Lockwasher 1/4"	8	
303	3300151	Nut, Acorn 1/4"-20NC	8	
304	4300031	Stud (Welded on Part)	8	
305		Rear Frame Shield Options:	1	
	4060606	All Machines Built Prior to May 1992		
	1670619	4WS Machines Only Built May 1992 to Present		

# SECTION 1 FRAME

FIGURE 1-3. OPTIONAL REAR STEER INSTALLATION

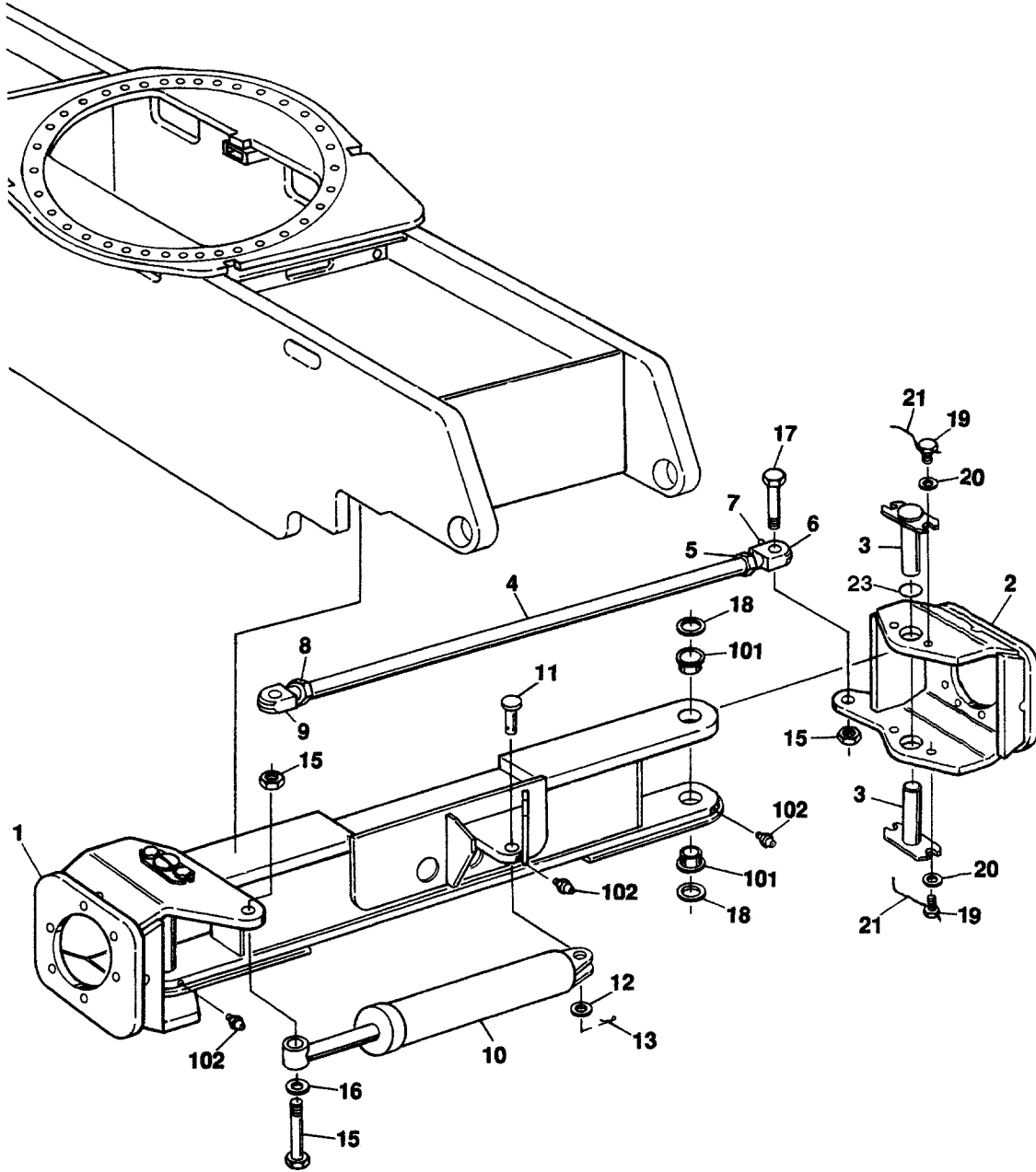

# SECTION 1 FRAME

**FIGURE 1-3. OPTIONAL REAR STEER INSTALLATION**

FIG & ITEM #	PART NUMBER	DESCRIPTION	QTY.	REV.
		<b>OPTIONAL REAR STEER INSTALLATION</b>	Ref.	
	0252288	<b>REAR STEER INSTALLATION</b>	Ref.	A
1	4130272	Spindle (LH)	1	
2	4130271	Spindle (RH)	1	
3	3422002	Kingpin	4	
4	3841142	Tie-Rod	1	
5	3300229	Nut, Jam 1 1/4"-12NF (LH Thread)	1	
6	0560714	Block, Tie-Rod (LH Thread)	1	
7	2160002	Fitting, Grease	2	
8	3323002	Nut, Jam 1 1/4"-12NF (RH Thread)	1	
9	0560605	Block, Tie-Rod (RH Thread)	1	
10	1681555	Steer Cylinder Assembly (See Section 5 for Breakdown)	1	
11	3431622	Pin, Clevis	1	
12	4712600	Flatwasher 1" Narrow	1	
13	3450606	Pin, Cotter 3/6" x 1"	1	
14	0630447	Bolt, Special	1	
15	3312602	Nut, Jam 1"-8NC	3	
16	0440091	Bearing, Thrust	3	
17	0630425	Bolt, Special	2	
18	4740391	Bearing, Thrust	2	
19	0630083	Bolt, Special	8	
20	4751600	Flatwasher 3/8"	8	
21	4920096	Wire, Safety	4 ft/1.2m	
22	0100011	Loctite #242 (Not Shown)	A/R	
23	3780187	O-Ring (March 1994 to Present)	8	
		<b>AXLE WELDMENT</b>	Ref.	
	4844003	<b>PRIOR TO JUNE 1994</b>	Ref.	-
	4844808	<b>JUNE 1994 TO PRESENT</b>	Ref.	-
101		Bushing, Bronze Options:	4	
	0961614	Prior to June 1994		
	0961850	June 1994 to Present		
102	2160002	Fitting, Grease	5	
103		Valve, Relief (Not Shown) Options:	4	
	Not Required	Prior to June 1994		
	4640812	June 1994 to Present		

# SECTION 1 FRAME

FIGURE 1-4. TIRE AND WHEEL DRIVE INSTALLATIONS

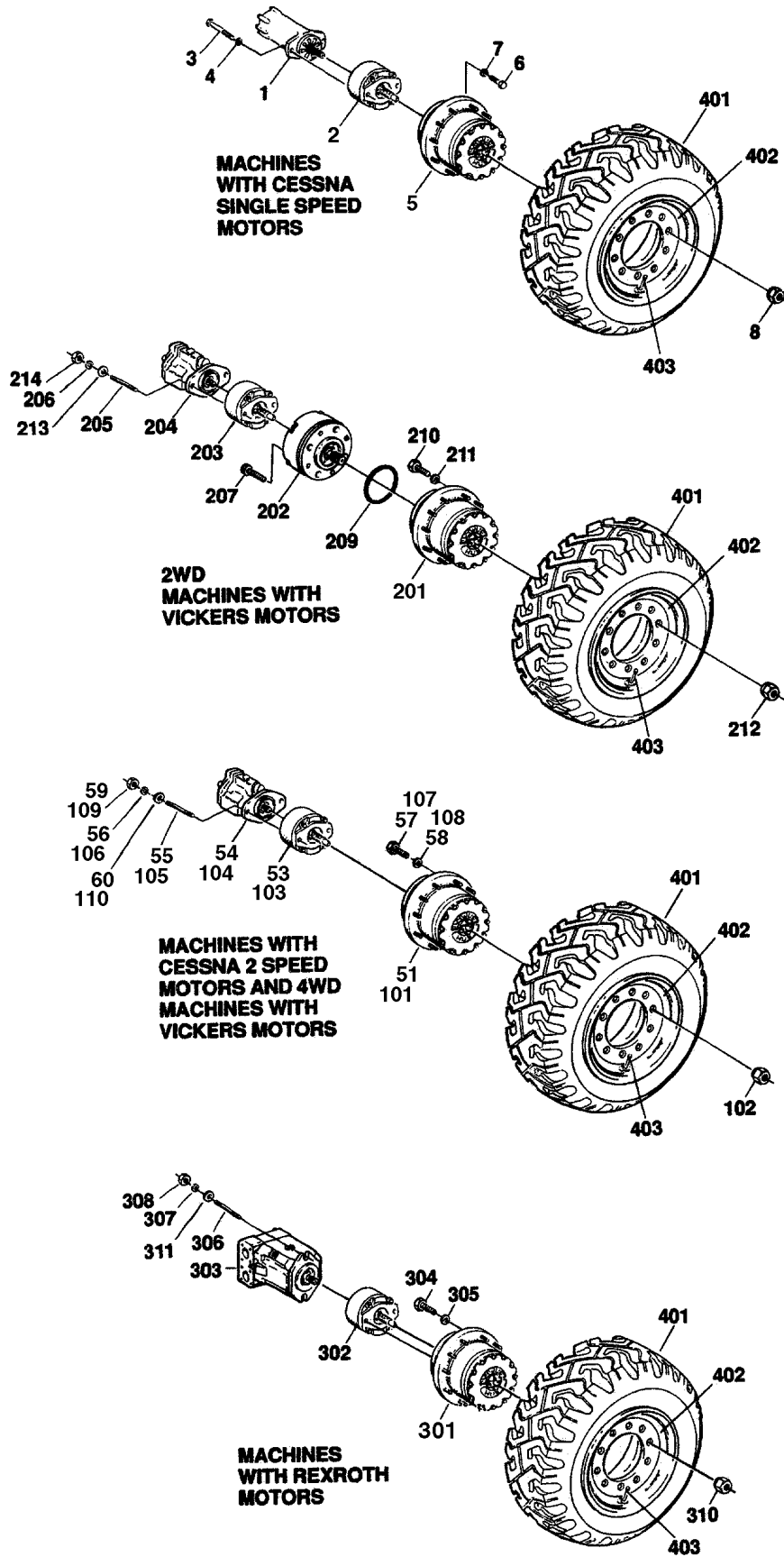



# SECTION 1 FRAME

**FIGURE 1-4. TIRE AND WHEEL DRIVE INSTALLATIONS**

FIG & ITEM #	PART NUMBER	DESCRIPTION	QTY.	REV.
		<b>WHEEL DRIVE INSTALLATION - MACHINES WITH CESSNA SINGLE SPEED MOTORS (USED WITH RACINE VALVES/MACHINES BUILT PRIOR TO EARLY 1987)</b>		
	0236825	<b>WHEEL DRIVE INSTALLATION - 60H 2WD WITH CESSNA SINGLE SPEED MOTORS</b>	Ref.	-
	0236840	<b>WHEEL DRIVE INSTALLATION - 70H 2WD WITH CESSNA SINGLE SPEED MOTORS</b>	Ref.	A
	0236839	<b>WHEEL DRIVE INSTALLATION - 60H/70H 4WD FRONT WITH CESSNA SINGLE SPEED MOTORS</b>	Ref.	B
	0236264	<b>WHEEL DRIVE INSTALLATION - 60H/70H 4WD REAR WITH CESSNA SINGLE SPEED MOTORS</b>	Ref.	E
1	3160104	Drive Motor Assembly - Cessna Single Speed (See Figure 1-5 for Breakdown)	2	
2		Brake Assembly Options:	2	
	0920027	60H & 70H 2WD With Cessna Single Speed Motors (See Figure 1-10 for Breakdown)		
	0920068	60H & 70H 4WD Front With Cessna Single Speed Motors (See Figure 1-11 for Breakdown) (Used Prior to August 1991)		
	0920086	60H & 70H 4WD Front With Cessna Single Speed Motors (See Figure 1-12 for Breakdown) (Used August 1991 to Present and for Service Replacement Requirements)		
	0920027	60H & 70H 4WD Rear With Cessna Single Speed Motors (See Figure 1-10 for Breakdown)		
3	0641844	Bolt 1/2" - 13NC x 5 1/2"	4	
4	4761800	Lockwasher 1/2"	4	
5		Hub Assembly Options (See Figure 1-16 for Breakdown):	2	
	2780110	Hub Assembly - 30:1 Ratio (60H 2WD With Cessna Single Speed Motors)		
	2780136	Hub Assembly - 43:1 Ratio (70H 2WD With Cessna Single Speed Motors)		
	2780135	Hub Assembly - 35:1 Ratio (60H & 70H 4WD Front With Cessna Single Speed Motors)		
	2780040	Hub Assembly - 35:1 Ratio (60H & 70H 4WD Rear With Cessna Single Speed Motors)		
6	0642016	Bolt 5/8"-11NC x 2"	16	
7	4762000	Lockwasher 5/8"	16	
8	3300007	Lugnut 3/4"-16NF	20	
		<b>WHEEL DRIVE INSTALLATION - MACHINES WITH CESSNA TWO SPEED MOTORS (USED WITH RACINE VALVES/OPTIONAL ON MACHINES BUILT PRIOR TO EARLY 1987)</b>		
	0236663		Ref.	A
51	2780114	Hub Assembly - 53.58:1 Ratio (See Figure 1-16 for Breakdown)	2	
52	3300007	Lugnut 3/4"-16NF	20	
53	0920027	Brake Assembly (See Figure 1-10 for Breakdown)	2	

# SECTION 1 FRAME

**FIGURE 1-4. TIRE AND WHEEL DRIVE INSTALLATIONS (CONTINUED)**

FIG & ITEM #	PART NUMBER	DESCRIPTION	QTY.	REV.
54	3160110	Drive Motor Assembly (See Figure 1-6 for Breakdown)	2	
55	0641844	Bolt 1/2"-13NC x 5 1/2" (Not Shown)	4	
56	4761800	Lockwasher 1/2"	4	
57	0642016	Bolt 5/8"-11NC x 2"	16	
58	4762000	Lockwasher 5/8"	16	
59	Not Required			
60	4751800	Flatwasher 1/2"	4	
		<b>WHEEL DRIVE INSTALLATION - 4WD MACHINES WITH VICKERS MOTORS USED WITH VICKERS VALVES (MACHINES BUILT 1987 TO MAY 1992)</b>	Ref.	
	0238301	<b>WHEEL DRIVE INSTALLATION - 60H 4WD FRONT DRIVE WITH VICKERS MOTORS</b>	Ref.	C
	0238315	<b>WHEEL DRIVE INSTALLATION - 60H 4WD REAR DRIVE WITH VICKERS MOTORS</b>	Ref.	D
	0238302	<b>WHEEL DRIVE INSTALLATION - 70H 4WD FRONT DRIVE WITH VICKERS MOTORS</b>	Ref.	C
	0238316	<b>WHEEL DRIVE INSTALLATION - 70H 4WD REAR DRIVE WITH VICKERS MOTORS</b>	Ref.	C
101	Not Used	Hub Assembly - 53.58:1 Ratio (See Figure 1-16 for Breakdown)	2	
102	3300007	Lugnut 3/4"-16NF	20	
103		Brake Assembly Options:	2	
	0920072	Machines Built Prior to March 1992 (See Figure 1-13 for Breakdown)		
	0920084	Machines Built March 1992 to S/N 33476 (See Figure 1-14 for Breakdown)		
	0920110	Machines Built S/N 33476 to Present (See Figure 1-14 for Breakdown)		
104		Motor Assembly - Vickers Options:	2	
	3160123	Front (See Figure 1-7 for Breakdown)		
	3160140	Rear (See Figure 1-8 for Breakdown)		
105	4300092	Stud 1/2"-13NC x 5 1/2"	4	
106	4761800	Lockwasher 1/2"	4	
107	0642016	Bolt 5/8"-11NC x 2"	16	
108	4762000	Lockwasher 5/8"	16	
109	3311801	Nut 1/2"-13NC	4	
110	4751800	Flatwasher 1/2"	4	

# SECTION 1 FRAME

**FIGURE 1-4. TIRE AND WHEEL DRIVE INSTALLATIONS (CONTINUED)**

FIG & ITEM #	PART NUMBER	DESCRIPTION	QTY.	REV.
201	0237793/ 0238312	<b>WHEEL DRIVE INSTALLATION - 2WD 60H WITH VICKERS MOTORS (USED WITH VICKERS VALVES/ MACHINES BUILT EARLY 1987 TO OCTOBER 1987)</b>	Ref.	2/4
	0237794/8093/ 8313	<b>WHEEL DRIVE INSTALLATION - 2WD 70H WITH VICKERS MOTORS (USED WITH VICKERS VALVES/ MACHINES BUILT OCTOBER 1987 TO MAY 1992)</b>	Ref.	A/3/6
		Hub Assembly Options:	2	
		Machines Built Early 1987 to October 1987	2	
	2780052	18.75:1 Ratio (Tapped Hub Mounting Holes) (Machines Built Prior to October 1987) (See Figure 1-16 for Breakdown)		
	2780145	18.75:1 Ratio (Tapped Frame Mounting Holes) (Machines Built October 1987 to May 1992) (See Figure 1-16 for Breakdown)		
	2780140	Machines Built October 1987 to May 1992 24:1 Ratio (Tapped Hub Mounting Holes) (Domestic Machines Built Prior to October 1987) (See Figure 1-16 for Breakdown)		
	2780142	24:1 Ratio (Tapped Frame Mounting Holes) (Domestic Machines Built October 1983 to May 1992) (See Figure 1-16 for Breakdown)		
	2780145	18.75:1 Ratio (CSA Machines Built through May 1992) (See Figure 1-16 for Breakdown)		
	202	2780138	Gear Reducer Assembly (See Figure 1-15 for Breakdown)	2
203		Brake Assembly Options:	2	
	0920072	Machines Built Prior to March 1992 (See Figure 1-13 for Breakdown)		
	0920084	Machines Built March 1992 to S/N 33476 (See Figure 1-14 for Breakdown)		
	0920110	Machines Built S/N 33476 to Present (See Figure 1-14 for Breakdown)		
204	3160132	Drive Motor Assembly - Vickers (See Figure 1-8 for Breakdown)	2	
205	4300092	Stud 1/2"-13NC x 5 1/2"	4	
206	4761800	Lockwasher 1/2"	4	
207	3931852	Capscrew, Socket Head 1/2"-13NC x 3 1/4"	8	
208	0100011	Loctite #242 (Not Shown)	A/R	
209	3790159	O-Ring	2	
210	0642016	Bolt 5/8"-11NC x 2"	16	
211	4762000	Lockwasher 5/8"	16	
212	3300007	Lugnut 3/4"-16NF	20	
213	4751800	Flatwasher 1/2"	4	
214	3311801	Nut 1/2"-13NC	4	

# SECTION 1 FRAME

**FIGURE 1-4. TIRE AND WHEEL DRIVE INSTALLATIONS (CONTINUED)**

FIG & ITEM #	PART NUMBER	DESCRIPTION	QTY.	REV.
		WHEEL DRIVE INSTALLATION - MACHINES WITH REXROTH MOTORS (USED WITH VICKERS VALVES/MACHINES BUILT MAY 1992 TO PRESENT) NOTE: DOUBLE QUANTITY FOR 4WD.	Ref.	
	0252365/ 0252367	WHEEL DRIVE INSTALLATION - 2WD MACHINES WITH REXROTH MOTORS (PRIOR TO S/N 51532)	Ref.	3/4
	0270161/ 0270214	WHEEL DRIVE INSTALLATION - 2WD MACHINES WITH REXROTH MOTORS (S/N 51532 TO PRESENT)	Ref.	1/1
	0253247	WHEEL DRIVE INSTALLATION - 4WD MACHINES WITH REXROTH MOTORS (PRIOR TO S/N 51532)	Ref.	4
	0270162	WHEEL DRIVE INSTALLATION - 4WD MACHINES WITH REXROTH MOTORS (S/N 51532 TO PRESENT)	Ref.	1
301		Hub Assembly Options (See Figure 1-16 for Breakdown):	A/R	
	2780187	2WD Hub Assembly - 73:1 Ratio	2	
	2780114	4WD Hub Assembly - 53.58:1 Ratio	4	
302		Brake Assembly Options (See Figure 1-14 for Breakdown):	2	
	0920084	Prior to S/N 33476		
	0920110	S/N 33476 to S/N 51432		
	0920117	S/N 51432 to Present		
303	See Note	Drive Motor Assembly - Rexroth (See Figure 1-9 for Breakdown)  <b>Note: Refer to Application</b> 2WD/2WS Rear - Use p/n 3160213 Motor Plus p/n 2900869 Conversion Kit as Replacement. 2WD/2WS Rear - Use p/n 3160204 Motor Plus p/n 2900869 Conversion Kit as Replacement. 4WD/2WS Front - Use p/n 3160204 Motor Plus p/n 2900869 Conversion Kit as Replacement. 4WD/2WS Rear - Use p/n 3160213 Motor Plus p/n 2900869 Conversion Kit as Replacement. 4WD/4WS Front & Rear - Use p/n 3160204 Motor Plus p/n 2900869 Conversion Kit as Replacement.	2	
304	0642016	Bolt 5/8"-11NC x 2"	16	
305	4762000	Lockwasher 5/8"	16	
306		Stud Options:	4	
	4300092	Stud 1/2"-13NC x 5 1/2" (Prior to S/N 51432)		
	4300097	Stud 1/2"-13NC x 5 1/8" (S/N 51432 to Present)		
307	4761800	Lockwasher 1/2"	4	
308	3311801	Nut 1/2"-13NC	4	
309	0100011	Loctite #242 (Not Shown)	A/R	
310	3300007	Lugnut 3/4"-16NF	20	
311	4751800	Flatwasher 1/2"	4	

# SECTION 1 FRAME

**FIGURE 1-4. TIRE AND WHEEL DRIVE INSTALLATIONS (CONTINUED)**

FIG & ITEM #	PART NUMBER	DESCRIPTION	QTY.	REV.
		<b>TIRE AND WHEEL ASSEMBLIES</b>	Ref.	
401		Pneumatic 14" Tire Options:	4	
	0236817	2WD Front		
	0236818	2WD Right Rear		
	0236819	2WD Left Rear		
	4520024	Tire Only - Front		
	4520025	Tire Only - Rear		
	4520171	Tire Only - Front & Rear		
	See Note	Foam-Filled 14" Tire Options:	4	
	0236625	2WD Front		
	0236627	2WD Right Rear		
	0236626	2WD Left Rear		
		<b>Note: Assemblies may require ballast/foam filling to manufacture's specifications prior to installing on a machine. Refer to Operation &amp; Safety or Service &amp; Maintenance Manuals. Purchase individual tire and/or rim only able to foam fill tire &amp; wheel assembly, otherwise, purchase complete assembly.</b>		
		Pneumatic 15" Tire Options:	4	
	0234666	2WD/2WS Front		
	0234666	2WD/4WS Front		
	0234667	2WD/2WS Right Rear		
	0234668	2WD/2WS Left Rear		
	0234666	2WD/4WS Rear		
	0252752	4WD/2WS Right Front and Rear		
	0271615	4WD/2WS Right Front and Rear		
	0252752	4WD/4WS Right Front and Rear		
	0271615	4WD/4WS Right Front and Rear		
	0252753	4WD/2WS Left Front and Rear		
	0271614	4WD/2WS Left Front and Rear		
	0252753	4WD/4WS Left Front and Rear		
	0271614	4WD/4WS Left Front and Rear		
	4520009	Firestone 15 x 19.5 Tire Only - 2WD Front		
	4520142	Denman 15 x 19.5 Tire Only - 2WD/2WS Rear		
	4520200	Galaxy 15 x 19.5 Tire Only - 2WD/2WS Rear		
	4520258	OTR 15 x 19.5 Tire Only - 2WD/2WS Rear		
	4520007	Firestone 15 x 19.5 Tire Only - 2WD/4WS Rear		
	4520142	Denman 15 x 19.5 Tire Only - 4WD All		
	4520258	OTR 15 x 19.5 Tire Only - 4WD All		
See Note	Foam-Filled 15" Tire Options:	4		
0236625	2WD/2WS Front			
0236625	2WD/4WS Front			
0234745	2WD/2WS Left Rear			
0234746	2WD/2WS Right Rear			
0236625	2WD/4WS Rear			
0234745	2WD/2WS Left Front and Rear			
0234745	4WD/4WS Left Front and Rear			
0234746	4WD/2WS Right Front and Rear			

# SECTION 1 FRAME

**FIGURE 1-4. TIRE AND WHEEL DRIVE INSTALLATIONS (CONTINUED)**

FIG & ITEM #	PART NUMBER	DESCRIPTION	QTY.	REV.
401 (cont'd)	0234746	4WD/4WS Right Front and Rear <b>Note: Assemblies may require ballast/foam filling to manufacture's specifications prior to installing on a machine. Refer to Operation &amp; Safety or Service &amp; Maintenance Manuals. Purchase individual tire and/or rim only able to foam fill tire &amp; wheel assembly, otherwise, purchase complete assembly.</b>		
402	4520178	Non-Marking Tire Option (Not Shown)		
	4520126	Solid Non-Marking Tire Option (Not Shown)		
	0236539	Rim Options: Rim - 14"		
	4860108	Rim - 15" (Prior to S/N 43309)		
403	4860148	Rim - 15" (S/N 43309 to Present)		
	Not Serviced	Rim - Foam-Filled (Purchase Complete Assembly)		
	4640113	Stem, Valve Options: Pneumatic		
404	Not Serviced	Foam-Filled		
		Decal - Tire Pressure Options (Not Shown Located at Valve Stem):	1	
	1703504	Prior to S/N 34051		
	1702701	S/N 34051 to Present		

# SECTION 1 FRAME

FIGURE 1-4. TIRE AND WHEEL DRIVE INSTALLATIONS (CONTINUED)

FIG & ITEM #	PART NUMBER	DESCRIPTION	QTY.	REV.

**S  
E  
C  
T  
I  
O  
N  
  
1  
  
F  
R  
A  
M  
E**

# SECTION 1 FRAME

FIGURE 1-5. DRIVE MOTOR ASSEMBLY - CESSNA (SINGLE SPEED)

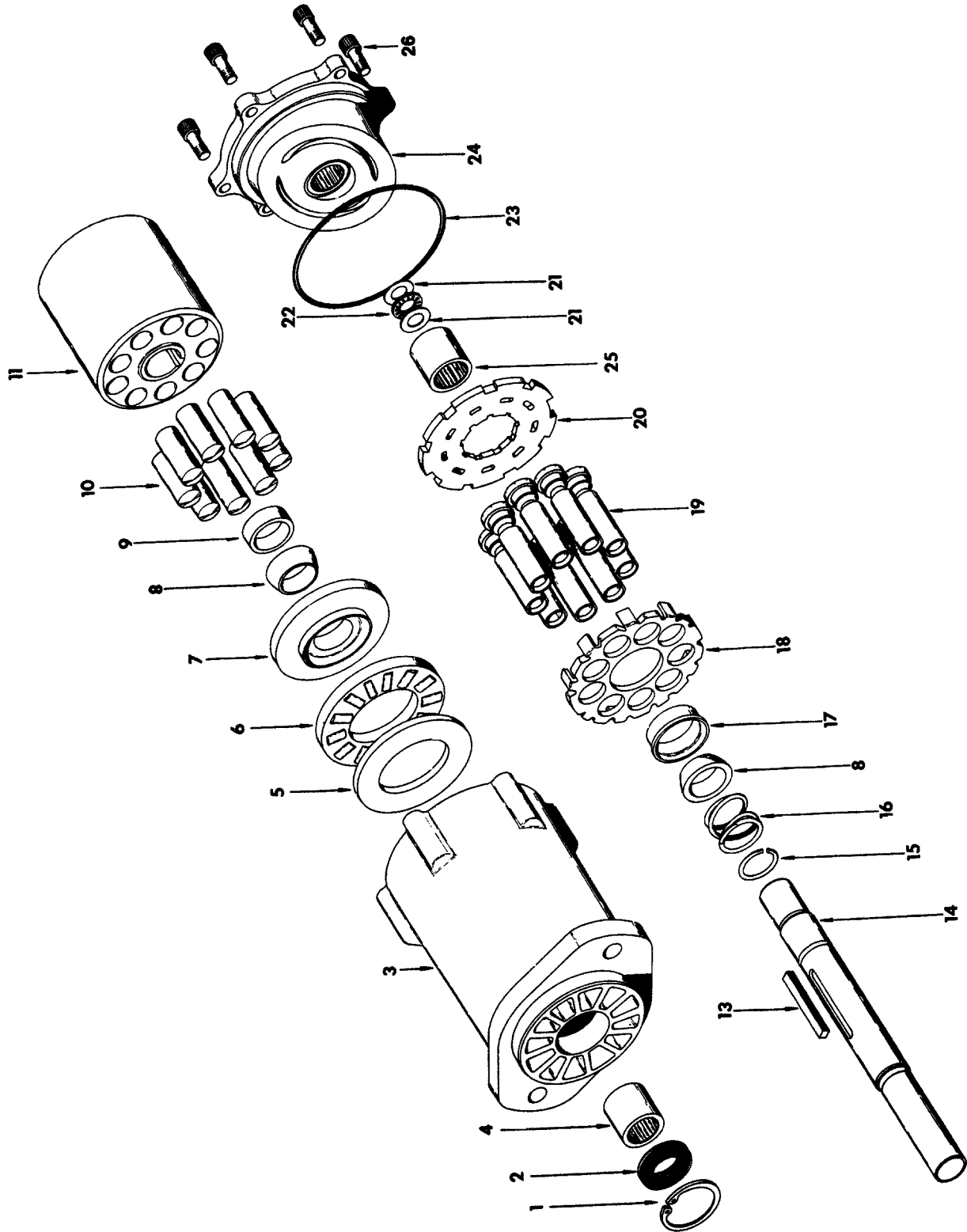



# SECTION 1 FRAME

**FIGURE 1-5. DRIVE MOTOR ASSEMBLY - CESSNA (SINGLE SPEED)**

FIG & ITEM #	PART NUMBER	DESCRIPTION	QTY.	REV.
	3160104	<b>DRIVE MOTOR ASSEMBLY - CESSNA (SINGLE SPEED)</b> <b>Note: Used With Racine Valves Built Prior To Mid 1987.</b>	Ref	A
1	Kit	Ring, Retaining	1	
2	Kit	Seal, Shaft	1	
3	7007594	Housing Assembly (With Bearing)	1	
4	7007593	Bearing	1	
5	7007595	Race, Bearing	1	
6	7007596	Bearing, Thrust	1	
7	7007597	Piston Race Assembly	1	
8	7007598	Pivot	1	
9	7007599	Spacer	1	
10	7007814	Kit, Piston Replacement	1	
11	7007800	Block, Piston	1	
12	Not Used			
13	7007801	Key	1	
14	7007802	Shaft, Drive	1	
15	7007803	Ring, Retaining	1	
16	7007804	Spring	1	
17	7007805	Pilot	1	
18	7007806	Spider	1	
19	7007807	Kit, Piston Replacement	1	
20	7007808	Plate, Connector	1	
21	7007809	Race, Thrust	2	
22	7007810	Bearing, Thrust	1	
23	Kit	O-Ring	1	
24	7007812	Back Plate Assembly (With Bearing)	1	
25	7007593	Bearing	1	
26	7007813	Bolt, Socket Head	6	
		-----		
	2900627	Seal Kit (Includes Items 1,2 and 23)	1	

# SECTION 1 FRAME

FIGURE 1-6. DRIVE MOTOR ASSEMBLY - CESSNA TWO SPEED.

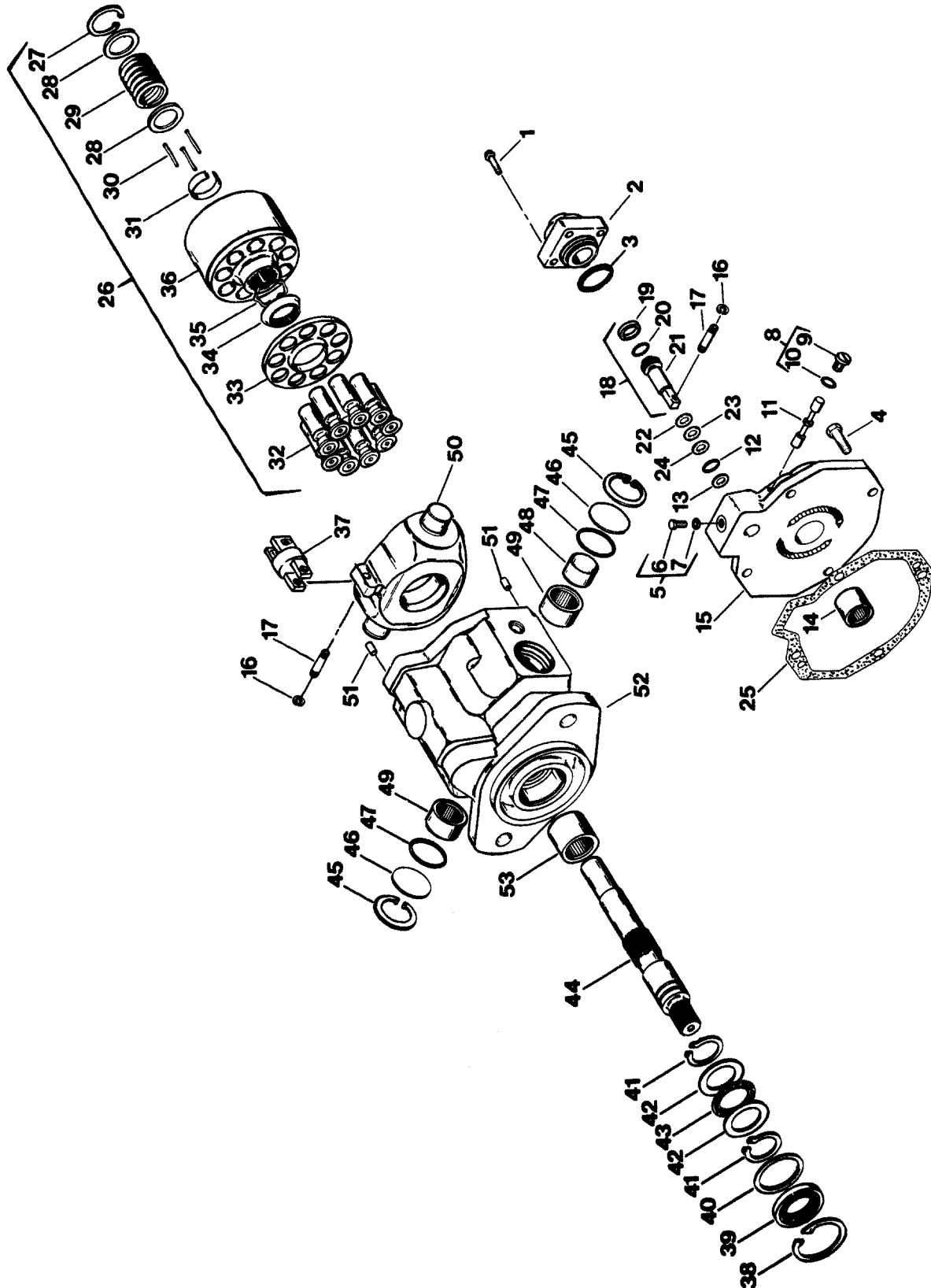

# SECTION 1 FRAME

**FIGURE 1-6. DRIVE MOTOR ASSEMBLY - CESSNA TWO SPEED.**

FIG & ITEM #	PART NUMBER	DESCRIPTION	QTY.	REV.
	3160110	<b>DRIVE MOTOR ASSEMBLY - CESSNA TWO SPEED</b> <b>Note: Used with Racine Valves Built Prior to Mid 1987.</b>	Ref.	
	7004939	Control Piston Housing Assembly	1	
1	7004938	Screw, Cap, Socket Head	4	
2	7004940	Housing, Control Piston	1	
3	Kit	O-Ring	1	
	7004941	Backplate Assembly	1	
4	7004933	Screw, Cap, Hex Head	4	
5	7004942	Plug Assembly	1	
6	7004943	Plug	1	
7	Kit	O-Ring	1	
8	7004944	Plug Assembly (Shuttle Spool)	2	
9	7004945	Plug	1	
10	Kit	O-Ring	1	
11	7004946	Spool, Shuttle	1	
12	Kit	O-Ring	1	
13	7004918	Washer, Back-up	1	
14	7004917	Bearing, Needle	1	
15	7004947	Backplate	1	
16	7004937	Ring, Retaining	4	
17	7004929	Pin, Connector	2	
18	7004948	Control Piston Assembly	1	
19	Kit	Ring, Slippery	1	
20	Kit	O-Ring	1	
21	7004949	Piston, Control	1	
22	7004925	Spacer, Piston	A/R	
23	7004924	Spacer, Piston	A/R	
24	7004926	Spacer, Piston	A/R	
25	Kit	Gasket, Housing	1	
26	7004916	Rotating Kit Assembly	1	
27	7004936	Ring, Retaining	1	
28	7004950	Washer, Machined	2	
29	7004951	Spring, Compression	1	
30	7004952	Pin, Loading	3	
31	7004953	Keeper, Pin	1	
32	7004954	Piston, Assembly	9	
33	7004955	Spider	1	
34	7004956	Pivot	1	
35	7004957	Washer, Wave	1	
36	7004958	Block, Piston	1	
37	7004928	Connector, Camplate	1	
38	Kit	Ring, Retaining	1	
39	Kit	Seal, Shaft	1	
40	7004906	Washer	1	
41	Kit	Ring, Retaining	2	
42	7004907	Race, Thrust	2	
43	7004908	Bearing, Thrust	1	
44	7004912	Shaft, Drive	1	

# SECTION 1 FRAME

SECTION 1 FRAME

**FIGURE 1-6. DRIVE MOTOR ASSEMBLY - CESSNA TWO SPEED. (CONTINUED)**

FIG & ITEM #	PART NUMBER	DESCRIPTION	QTY.	REV.
45	Kit	Ring, Retaining	2	
46	7004913	Cover, Trunnion	2	
47	Kit	O-Ring	2	
48	7004911	Race, Inner	1	
49	7004914	Bearing	2	
50	7004927	Camplate	1	
	7004959	Housing Assembly	1	
51	7004960	Pin, Roll (1/4" Dia. x 1/2" Long)	2	
52	7004961	Housing	1	
53	7004910	Bearing	1	
		-----		
	2900449	Seal Repair Kit (Includes Items 3,7,10,12,19,20,25,38,39,41,45 and 47)	Ref.	

# SECTION 1 FRAME

FIGURE 1-6. DRIVE MOTOR ASSEMBLY - CESSNA TWO SPEED. (CONTINUED)

FIG & ITEM #	PART NUMBER	DESCRIPTION	QTY.	REV.

**S  
E  
C  
T  
I  
O  
N  
  
1  
  
F  
R  
A  
M  
E**

# SECTION 1 FRAME

FIGURE 1-7. DRIVE MOTOR ASSEMBLY - VICKERS (4WD FRONT).

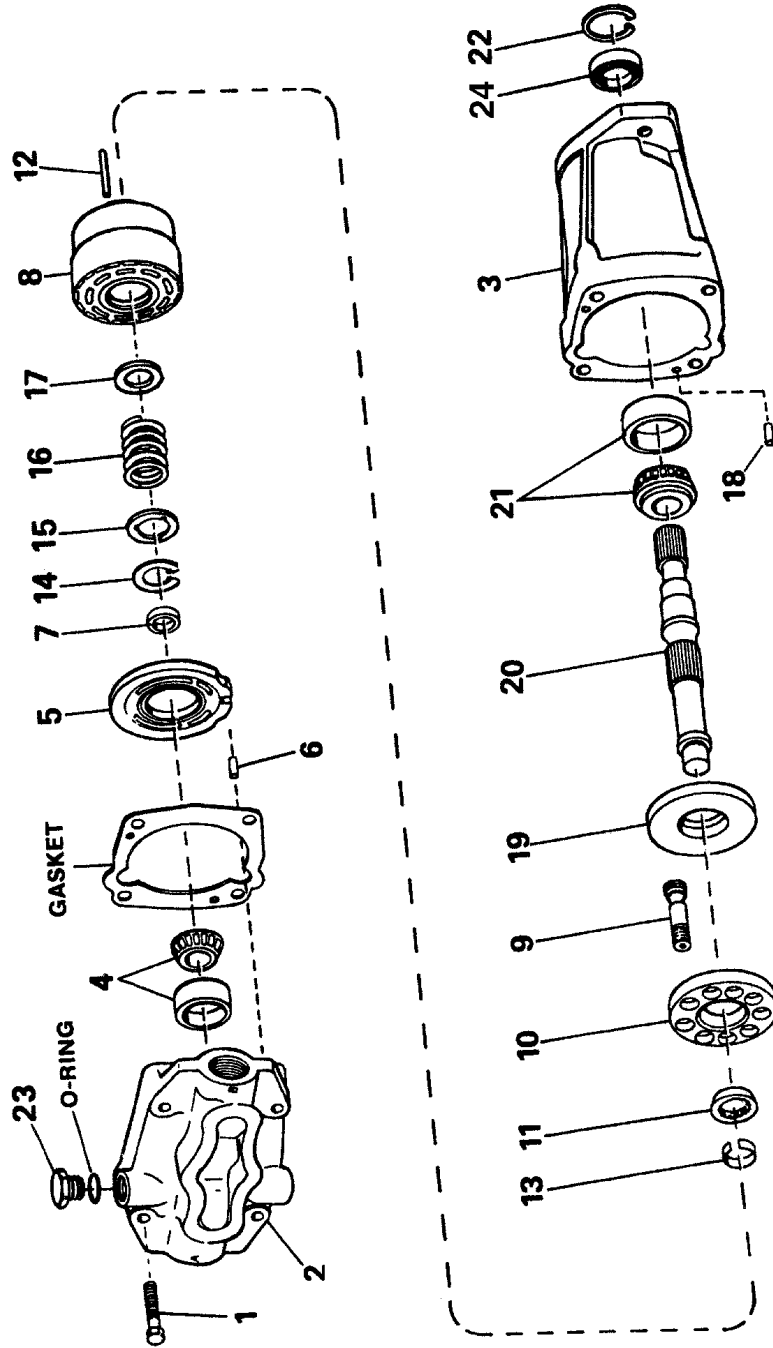

# SECTION 1 FRAME

**FIGURE 1-7. DRIVE MOTOR ASSEMBLY - VICKERS (4WD FRONT).**

FIG & ITEM #	PART NUMBER	DESCRIPTION	QTY.	REV.
	3160123	<b>DRIVE MOTOR ASSEMBLY - VICKERS (4WD FRONT)</b> <b>Note: Used with Vickers Valves Built 1987 to 1982</b>	Ref.	—
1	7006701	Screw	4	
2	7006702	Block, Valve	1	
3	7006722	Housing	1	
4	7006704	Bearing and Race	1	
5	7006705	Wafer Plate	1	
6	7006706	Pin	1	
7	7006707	Spacer	1	
8	7006712	Cylinder Block	1	
9	7006717	Piston and Shoe	9	
10	7006716	Shoe Plate	1	
11	7006715	Washer, Spherical	1	
12	7006713	Pin	3	
13	7006714	Retainer Pin	1	
14	7006708	Ring, Retaining	1	
15	7006709	Washer	1	
16	7006710	Spring	1	
17	7006711	Washer, Thrust	1	
18	7006720	Pin Alignment	2	
19	7006718	Swash Plate	1	
20	7006700	Shaft	1	
21	7006719	Bearing and Race	1	
22	7006721	Ring, Retaining	1	
23	7006703	Plug	1	
24	7006796	Seal, Shaft	1	
		-----		
	7006723	Kit, Rotating Group (Includes Items 8 through 17 and Item 19)	1	
	2900595	Kit, Seal (Includes Gasket, Shaft Seal and Plug O-Ring)	1	

# SECTION 1 FRAME

FIGURE 1-8. DRIVE MOTOR ASSEMBLY - VICKERS (2WD AND 4WD REAR)

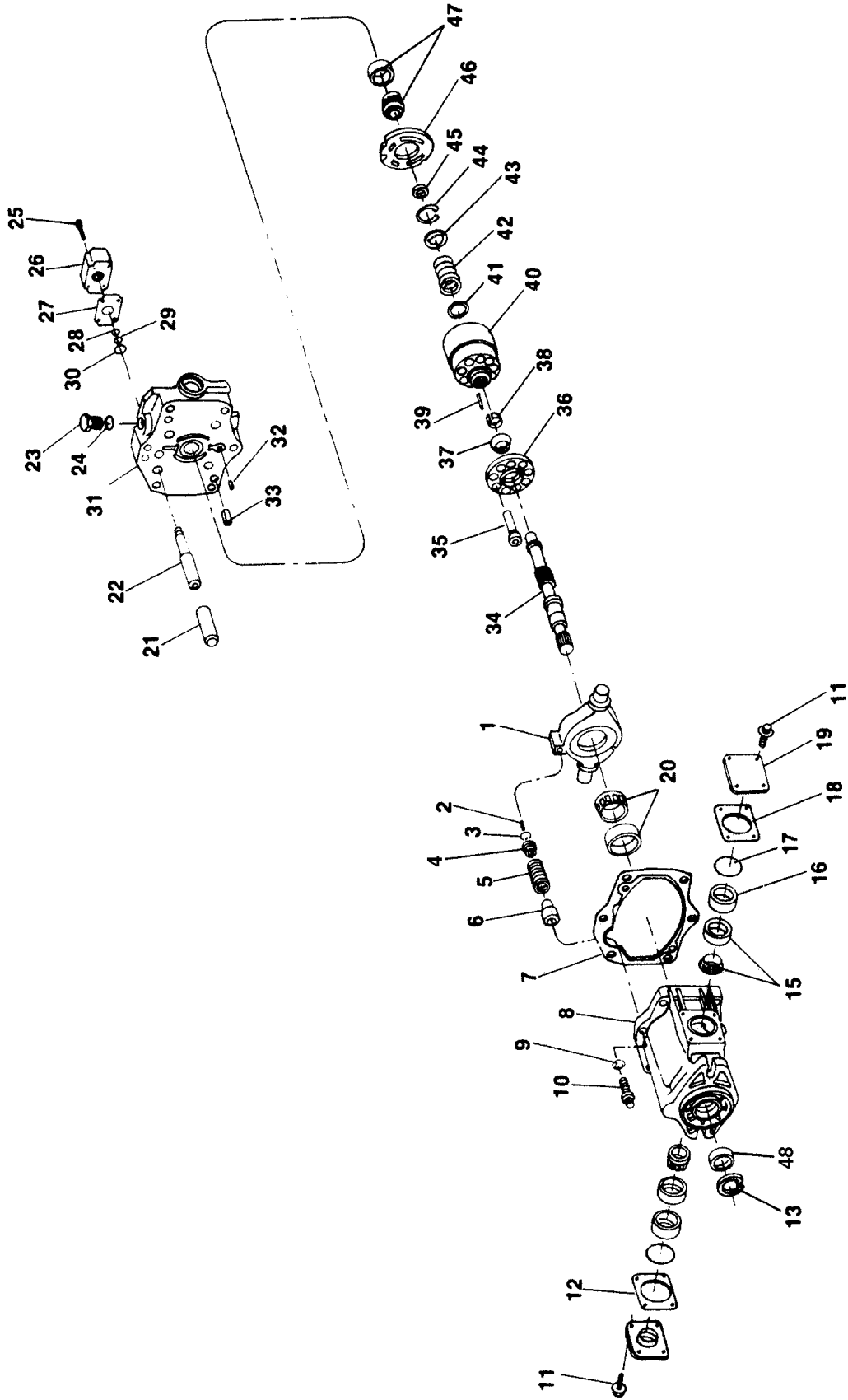



# SECTION 1 FRAME

**FIGURE 1-8. DRIVE MOTOR ASSEMBLY - VICKERS (2WD AND 4WD REAR)**

FIG & ITEM #	PART NUMBER	DESCRIPTION	QTY.	REV.
	3160140	<b>DRIVE MOTOR ASSEMBLY - VICKERS (4WD REAR)</b>	Ref.	A
	3160132	<b>DRIVE MOTOR ASSEMBLY - VICKERS (2WD REAR)</b>	Ref.	B
		<b>Note: Used with Vickers Valves Built 1987 to May 1992.</b>		
1	7006766	Yoke	1	
2	7006767	Roll Pin	1	
3	7006768	Spherical Seat	1	
4		Seat, Spring Options:	1	
	7006772	4WD Rear		
	7006769	2WD Rear		
5	7006774	Yoke Spring	1	
6	7006776	Yoke Stop	1	
7	Kit	Gasket	1	
8	7006786	Housing	1	
9	7006787	Washer	6	
10	7006788	Screw	6	
11	7006789	Screw	4	
12		Shim (Included in Kit 7006794)	1	
13	7006721	Retaining Ring	1	
14	Not Used			
15	7006791	Bearing	2	
16	7006792	Printle Bearing	2	
17	Kit	O-Ring	2	
18	7006794	Shim Kit	1	
19	7006795	Cover	2	
20	7006719	Bearing	1	
21	7006797	Piston	1	
22	7006798	Piston Rod	1	
23	7006703	Plug	1	
24	Kit	O-Ring	1	
25	7009300	Screw	4	
26	7009301	Control Block	1	
27	Kit	Gasket	1	
28	Kit	O-Ring	1	
29	Kit	Back-Up Ring	1	
30	7009305	Retaining Ring	1	
31	7009306	Valve Block	1	
32	7006706	Pin	1	
33	7009307	Pin	2	
34	7009308	Shaft	1	
35	7006717	Piston and Shoes	9	
36	7006716	Shoe Plate	1	
37	7006715	Spherical Washer	1	
38	7006714	Pin, Retainer	1	
39	7006713	Pin	3	
40	7006712	Cylinder, Block	1	
41	7006711	Spring Washer	1	

# SECTION 1 FRAME

**SECTION 1 FRAME**

**FIGURE 1-8. DRIVE MOTOR ASSEMBLY - VICKERS (2WD AND 4WD REAR) (CONTINUED)**

FIG & ITEM #	PART NUMBER	DESCRIPTION	QTY.	REV.
42	7006710	Spring	1	
43	7006709	Spring Washer	1	
44	7009309	Retaining Ring	1	
45	7006707	Bearing Spacer Kit	1	
46	7009310	Wafer Plate	1	
47	7006704	Bearing S/A	1	
48	7006796	Seal, Shaft	1	
		-----		
	2900659	Seal Kit (Includes Items 7,17,24 and 27-29)	1	

# SECTION 1 FRAME

FIGURE 1-8. DRIVE MOTOR ASSEMBLY - VICKERS (2WD AND 4WD REAR) (CONTINUED)

FIG & ITEM #	PART NUMBER	DESCRIPTION	QTY.	REV.

**S  
E  
C  
T  
I  
O  
N  
  
1  
  
F  
R  
A  
M  
E**

# SECTION 1 FRAME

FIGURE 1-9. DRIVE MOTOR ASSEMBLY - REXROTH

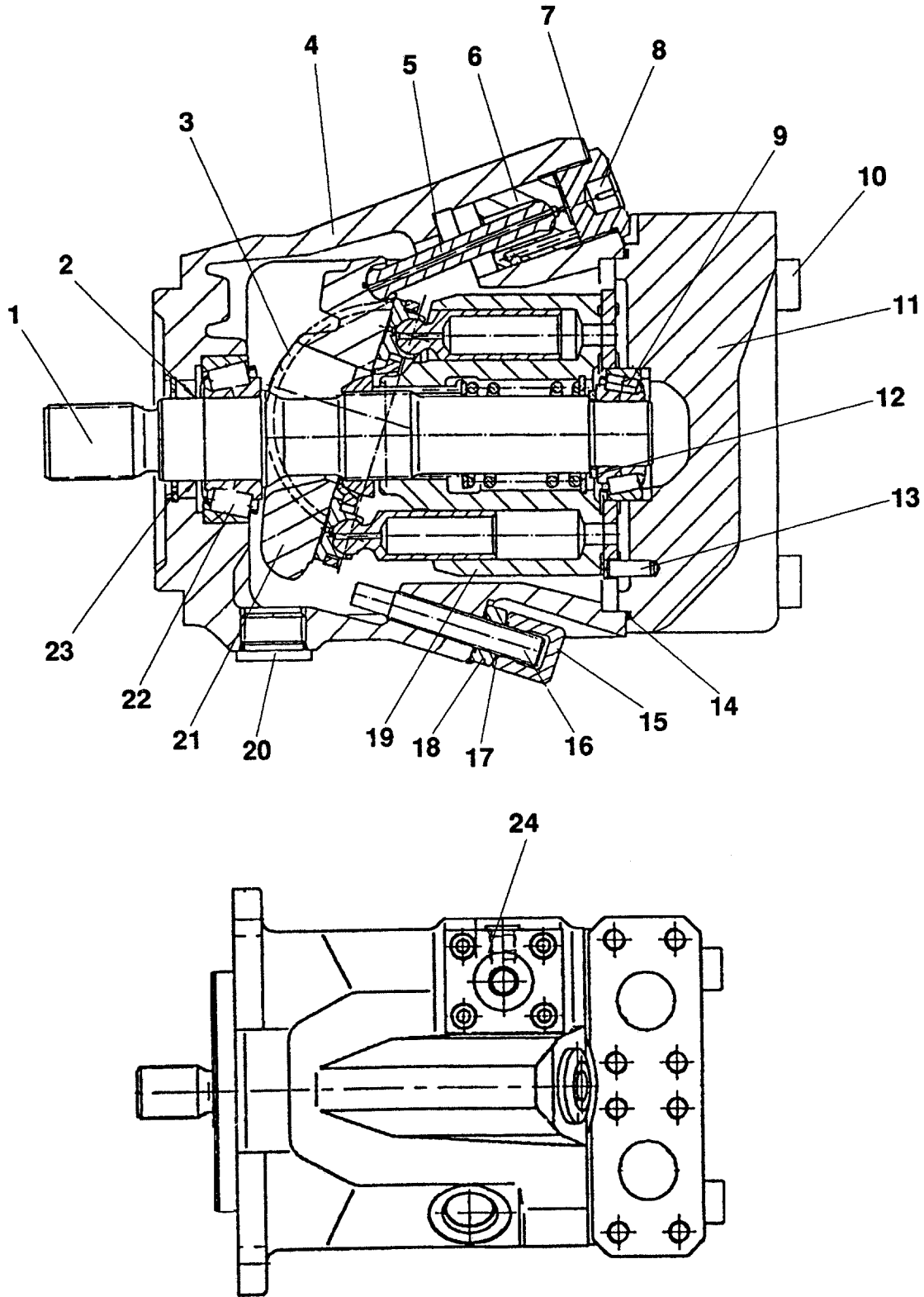

# SECTION 1 FRAME

**FIGURE 1-9. DRIVE MOTOR ASSEMBLY - REXROTH**

FIG & ITEM #	PART NUMBER	DESCRIPTION	QTY.	REV.
	3160204	<b>DRIVE MOTOR ASSEMBLY - REXROTH</b> <b>Note: Used with Vickers Valves built May 1992 to Present)</b>	Ref.	A
1	7012701	Shaft - 13 Teeth	1	
2	Kit	Seal, Shaft	1	
3	7012702	Bearing, Cradle	2	
4	Not Available	Housing	1	
5	7012703	Rod, Piston	1	
6	7012704	Piston, Stroking	1	
7	Kit	O-Ring	1	
8	7012705	Nut, Adaptor	1	
9	7012706	Bearing, Roller	1	
10	7012707	Bolt, Metric Socket Head M12 x 65	4	
11	7012708	Block, Port	1	
12	7012709	Shim	1	
13	7012710	Pin, Dowel M6 x 18	1	
14	Kit	O-Ring	1	
15	7012711	Nut, Cap M10 x 1	1	
16	7012712	Screw, Adjusting	1	
17	Kit	O-Ring	1	
18	7012713	Nut, Jam M10 x 1	1	
19	Kit	Rotary Group Assembly	1	
20	Not Available	Plug	1	
21	Kit	Plate, Swash	1	
22	7012714	Bearing, Roller	1	
23	7012715	V-Ring	1	
24	7012700	Control Plate Assembly	1	
		-----		
	2900788	Seal Kit (Includes Items 2, 7, 14, 17 and O-Rings under Item 24)	1	
	7012716	Rotary Group Kit (Includes Items 19 and 21)	1	

# SECTION 1 FRAME

FIGURE 1-10. BRAKE ASSEMBLY - AUSCO AND MICO

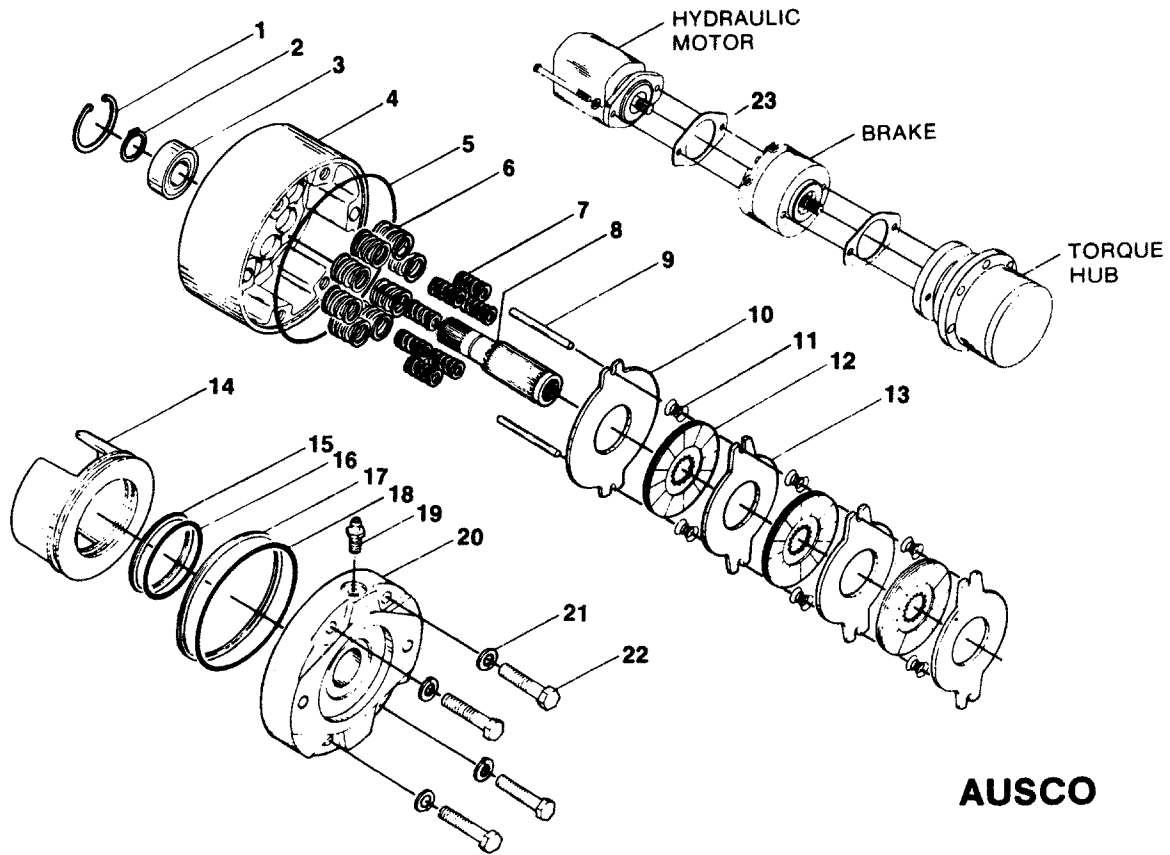

**AUSCO**

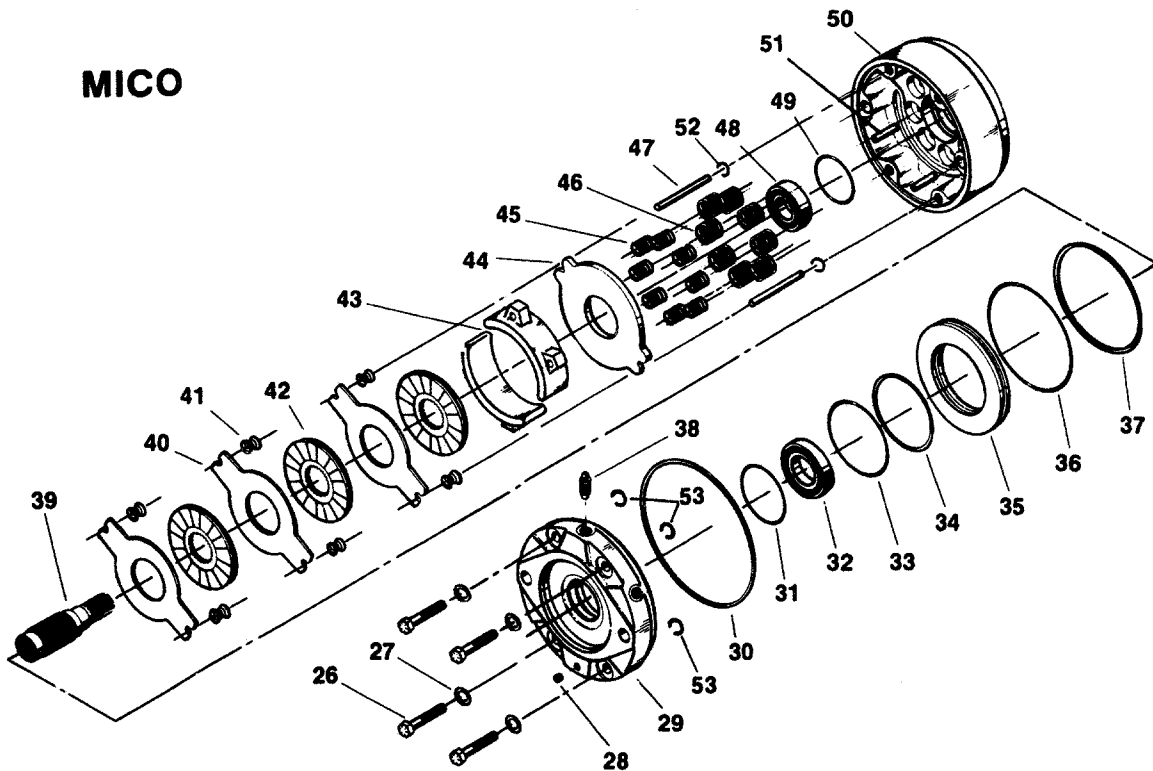

**MICO**

# SECTION 1 FRAME

**FIGURE 1-10. BRAKE ASSEMBLY - AUSCO AND MICO**

FIG & ITEM #	PART NUMBER	DESCRIPTION	QTY.	REV.
	0920027	<b>BRAKE ASSEMBLY - AUSCO AND MICO (2WD AND 4WD REAR WITH CESSNA MOTORS)</b> <b>Note: Used with Racine Valves and Cessna Motors built Prior to Mid 1987.</b>	Ref.	G
		<b>BRAKE ASSEMBLY - AUSCO</b>	Ref.	
1	Kit	Ring, Retaining	1	
2	Kit	Ring, Retaining	1	
3	7000713	Bearing, Ball	1	
4	7000714	Housing	1	
	7003010	Retainer, Spring	1	
5	7000759	O-Ring	1	
6	7000782	Spring, Compression	8	
7	7000798	Spring, Compression	8	
8	7000716	Shaft	1	
9	7000717	Pin, Torque	2	
10	7000718	Disc, Primary	1	
11	7003006	Spring, Compression	6	
12	7000732	Disc, Rotating	3	
13	7000720	Disc, Stationary	3	
14	7000721	Piston	1	
15	Kit	Ring, Back-Up	1	
16	Kit	O-Ring	1	
17	Kit	Ring, Back-Up	1	
18	Kit	O-Ring	1	
19	7000796	Bleeder	1	
20	7000727	Plate, Power	1	
21	7000729	Lockwasher	4	
22	7000730	Bolt	4	
	7003007	Bolt, Flanged	4	
23	Kit	Gasket	2	
24	Not Used			
25	Not used			
	2900131	Seal Kit (Includes items 1, 2, 15, 16, 17, 18 and 24)	1	
		<b>BRAKE ASSEMBLY - MICO</b>	Ref.	
26	7007913	Cap Screw	4	
27	7007912	Lockwasher	4	
28	7007924	Pipe Plug	1	
29	7007975	Cover	1	
30	Kit	Square Ring	1	
31	Kit	O-Ring	1	
32	7007920	Bearing	1	
33	Kit	O-Ring	1	
34	Kit	Back-Up Ring	1	
35	7007923	Piston	1	

# SECTION 1 FRAME

**SECTION 1 FRAME**

**FIGURE 1-10. BRAKE ASSEMBLY - AUSCO AND MICO (CONTINUED)**

FIG & ITEM #	PART NUMBER	DESCRIPTION	QTY.	REV.
36	Kit	O-Ring	1	
37	kit	Back-Up Ring	1	
38	7007914	Bleeder Screw	1	
39	7007903	Shaft	1	
40	7007908	Disc	3	
41	7007916	Spring	6	
42	7007909	Friction Disc	3	
43	7007902	Separator	2	A
44	7007907	Disc (Large Diameter)	1	
45	7007906	Spring	8	
46	7007905	Spring	8	
47	7007915	Pin, Dowel	2	
48	7007904	Bearing	1	B
49	Kit	Oil Seal	1	
50	7007976	Housing	1	
51	7007901	Spirol Pin	4	
52	Kit	O-Ring	2	
53	Kit	O-Ring	4	
	7007933	Mounting Gasket (Not Shown)	1	
		-----		
	2900641	Seal Kit (Includes Items 30,31,32,33,34,36,37,49,52 and 53)	1	



# SECTION 1 FRAME

FIGURE 1-10. BRAKE ASSEMBLY - AUSCO AND MICO (CONTINUED)

FIG & ITEM #	PART NUMBER	DESCRIPTION	QTY.	REV.

**S  
E  
C  
T  
I  
O  
N  
  
1  
  
F  
R  
A  
M  
E**

# SECTION 1 FRAME

FIGURE 1-11. BRAKE ASSEMBLY - AUSCO 29479 (4WD FRONT)

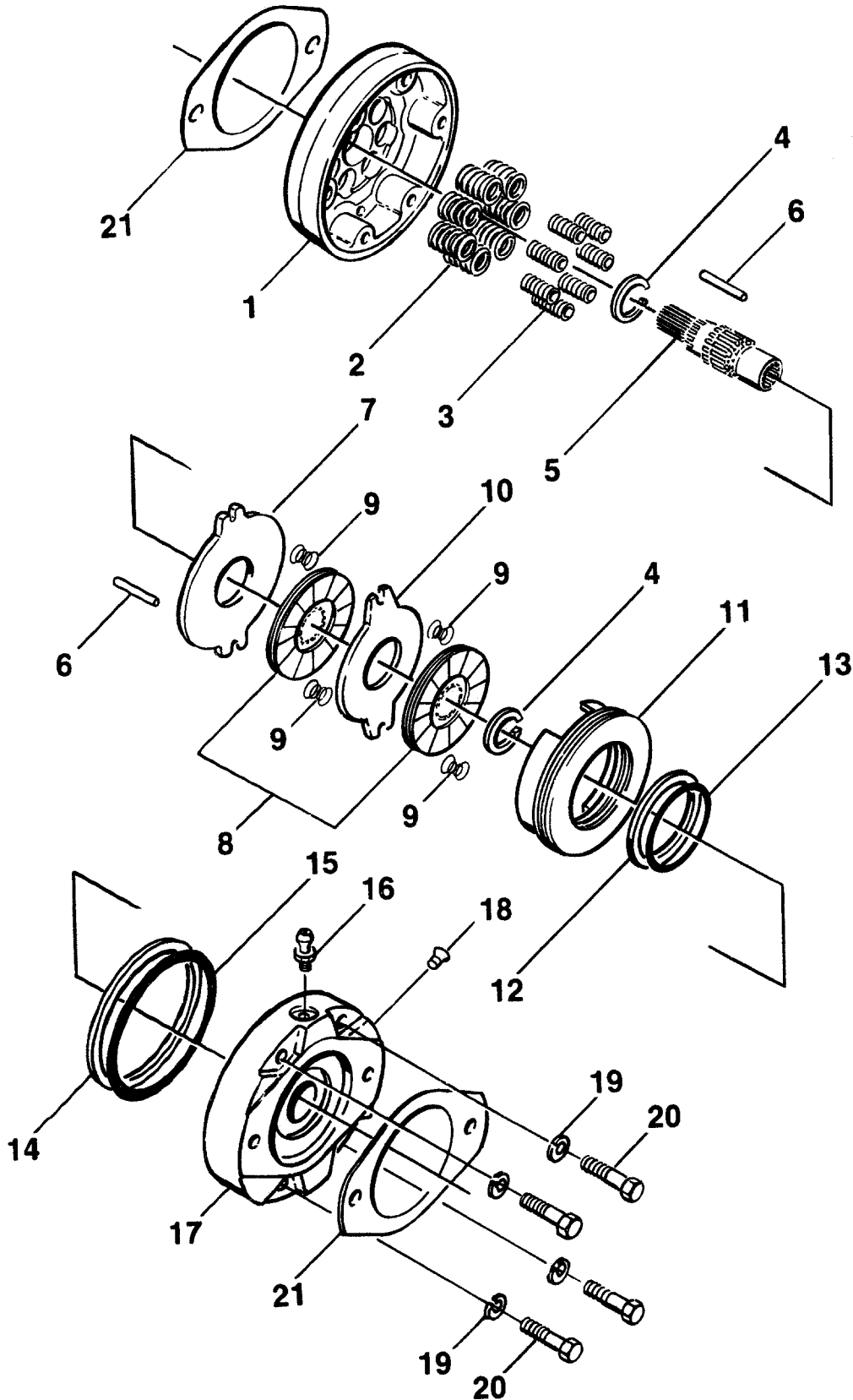

# SECTION 1 FRAME

**FIGURE 1-11. BRAKE ASSEMBLY - AUSCO 29479 (4WD FRONT)**

FIG & ITEM #	PART NUMBER	DESCRIPTION	QTY.	REV.
	0920068	<b>BRAKE ASSEMBLY - AUSCO 29479 (4WD FRONT)</b> <b>Note: Used with Racine Valves and Cessna Drive Motors built Prior to Mid 1987. Use 0920086 Brake if replacing complete Assembly.</b>	Ref.	B
1	7003067	Housing	1	
2	7000782	Spring, Compression	7	
3	7000798	Spring, Compression	7	
4	7003060	Ring, Retaining	2	
5	7003061	Shaft, Splined	1	
6	7003062	Pin, Torque	2	
7	7000718	Disc, Primary	1	
8	7000732	Disc, Rotating	2	
9	7003006	Spring, Compression	4	
10	7003063	Disc, Stationary	1	
11	7003064	Piston	1	
12	Kit	Ring, Back-up	1	1
13	Kit	O-Ring	1	
14	Kit	Ring, Back-up	1	
15	Kit	O-Ring	1	
16	7000796	Bleeder	1	
17	7003065	Plate, Power	1	
18	7000728	Plug	1	
19	7000729	Lockwasher	4	
20	7003066	Bolt	4	
21	Kit	Gasket	2	
	2900649	Seal Kit (Includes Items 12,13,14,15 and 21)	1	
	7003069	Gasket Kit (Includes Item 21)	1	

# SECTION 1 FRAME

FIGURE 1-12. BRAKE ASSEMBLY - AUSCO 37845 (4WD FRONT)

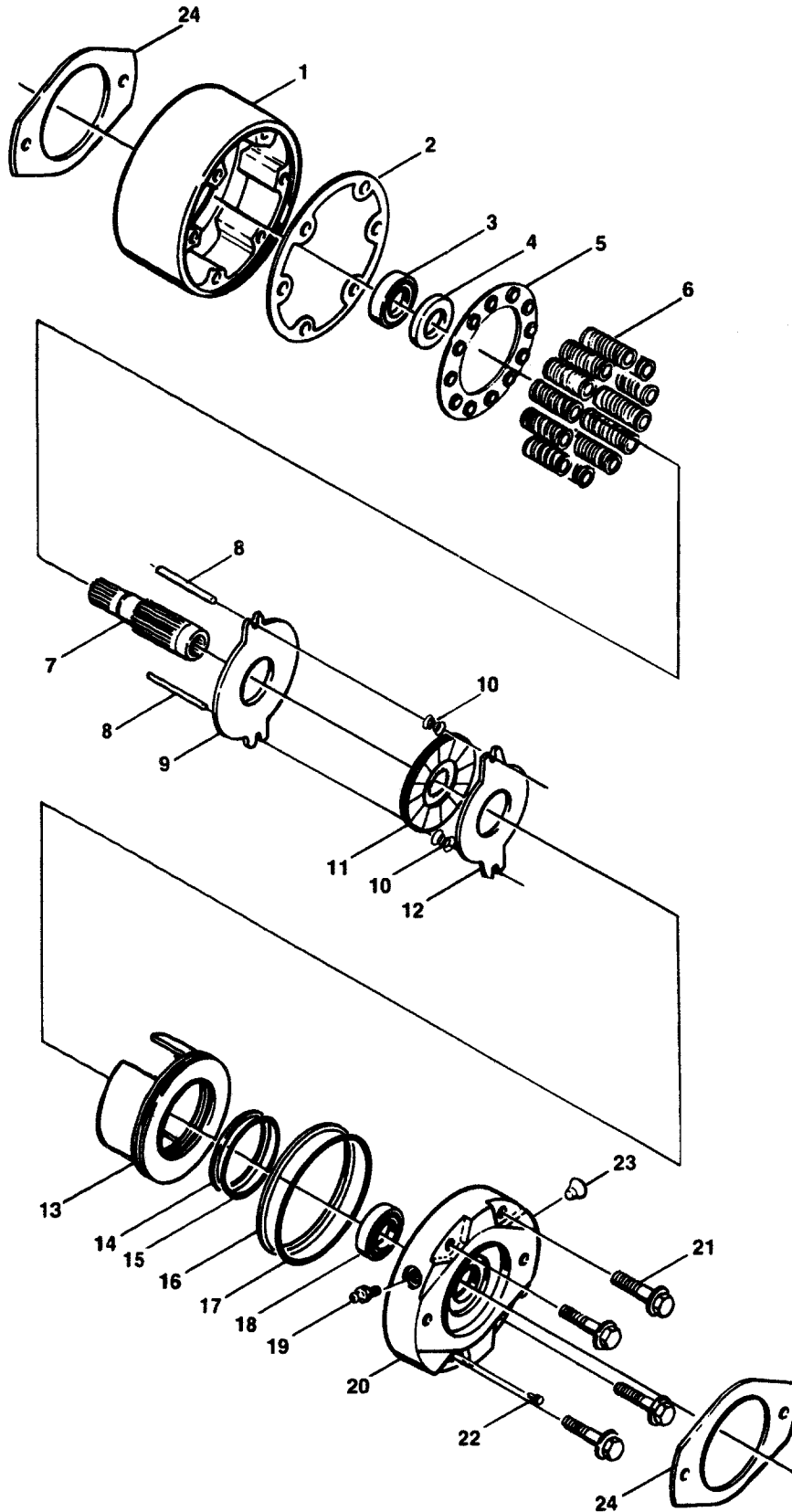

# SECTION 1 FRAME

**FIGURE 1-12. BRAKE ASSEMBLY - AUSCO 37845 (4WD FRONT)**

FIG & ITEM #	PART NUMBER	DESCRIPTION	QTY.	REV.
	0920086	<b>BRAKE ASSEMBLY - AUSCO 37845 (4WD FRONT)</b> <b>Note: Used with Racine Valves and Cessna Drive Motors as a service replacement for 0920068 Brake.</b>	Ref.	A
1	7003092	Housing	1	
2	Kit	Gasket	1	
3	7003049	Ball Bearing	1	
4	7003050	Oil Seal	1	
5	7003051	Spring Retainer	1	
6	7003052	Compression Spring	12	
7	7003093	Shaft	1	
8	7003094	Torque Pin	2	
9	7003054	Primary Disc	1	
10	7003006	Compression Spring	2	
11	7003055	Rotating Disc	1	
12	7003056	Stationary Disc	1	
13	7003095	Piston	1	
14	Kit	Backup Ring	1	
15	Kit	O-Ring	1	
16	Kit	Backup Ring	1	
17	Kit	O-Ring	1	
18	7000760	Ball Bearing	1	
19	7000796	Bleeder Screw	1	
20	7003096	Power Plate	1	
21	7003007	Hex Screw	4	
22	7003059	Pressure Relief Valve	1	
23	N.S.	Plug Shipping	1	
24	Kit	Gasket	2	
	2900662	O-Ring Kit (Includes items 2,14-17 and 24)	1	
	7003069	Gasket Kit (Includes Item 24)	1	

# SECTION 1 FRAME

FIGURE 1-13. BRAKE ASSEMBLY - AUSCO (2WD REAR)

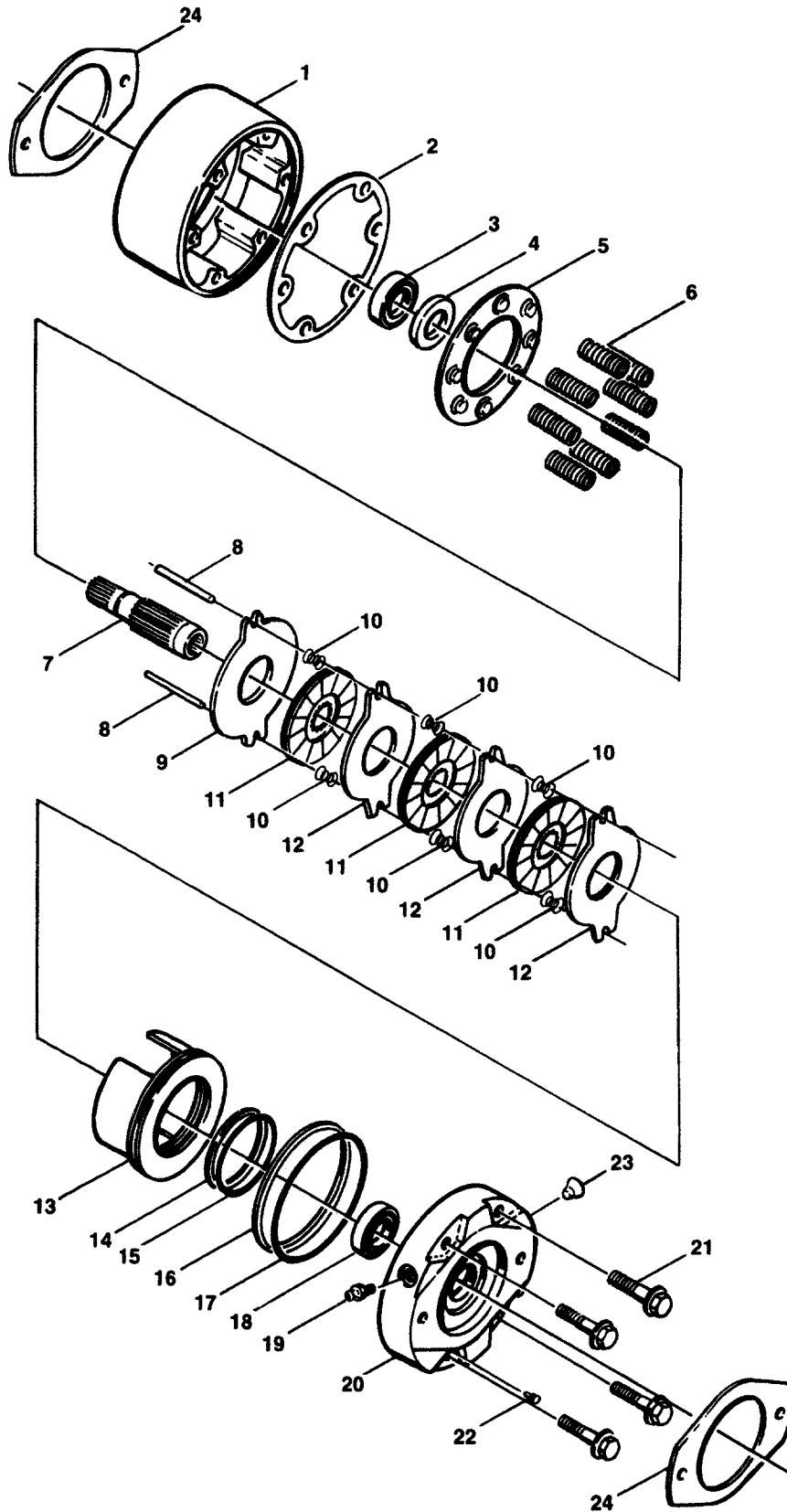

# SECTION 1 FRAME

**FIGURE 1-13. BRAKE ASSEMBLY - AUSCO (2WD REAR)**

FIG & ITEM #	PART NUMBER	DESCRIPTION	QTY.	REV.
	0920072	<b>BRAKE ASSEMBLY - AUSCO (2WD REAR)</b> <b>Note: Used with Vickers Valves and Vickers Motors built 1987 to March 1992.</b>	Ref.	D
1	7003047	Housing	1	
2	Kit	Gasket	1	
3	7003049	Bearing	1	
4	Kit	Seal, Oil	1	
5	7003051	Retainer, Spring	1	
6	7003052	Spring, Compression	8	
7	7003070	Shaft, Splined	1	
8	7000717	Pin, Torque	2	
9	7003054	Disc, Primary	1	
10	7003006	Spring, Separator	6	
11	7003055	Disc, Rotating	3	
12	7003056	Disc, Stationary	3	
13	7003057	Piston	1	
14	Kit	Ring, Backup	1	
15	Kit	O-Ring	1	
16	Kit	O-Ring	1	
17	Kit	O-Ring	1	
18	7000760	Bearing	1	
19	7000796	Screw, Bleeder	1	
20	7003071	Plate, Power	1	
21	7003007	Screw	4	
22	7003059	Valve, Pressure	1	
23	7000728	Plug	1	
24	Kit	Gasket	2	
	2900662	Seal Kit (Includes Items 2,4,14,15,16,17 and 24)	1	
	7003069	Gasket Kit (Includes Item 24)	1	

# SECTION 1 FRAME

FIGURE 1-14. BRAKE ASSEMBLY - MICO

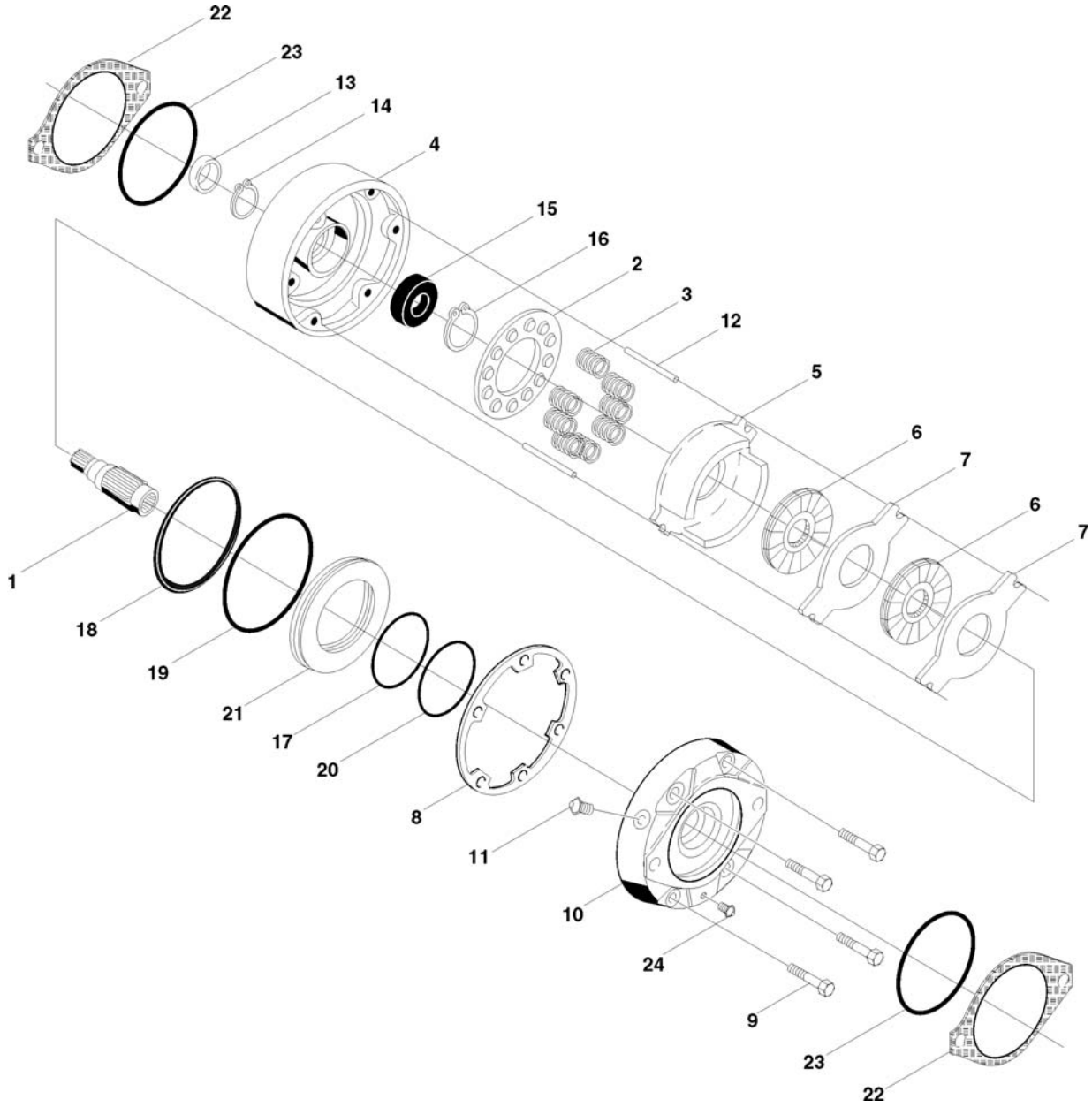



# SECTION 1 FRAME

**FIGURE 1-14. BRAKE ASSEMBLY - MICO**

FIG & ITEM #	PART NUMBER	DESCRIPTION	QTY.	REV.
	0920084	<b>Prior to S/N 33476</b>	Ref.	A
	0920110	<b>S/N 33476 to S/N 51532</b>	Ref.	B
	0920117	<b>S/N 51532 to S/N 57512 (Replace complete unit with p/n 0920119)</b>	Ref.	B
	0920119	<b>S/N 57512 to Present</b>	Ref.	A
		<b>Note: Used on 60H 2WD &amp; 4WD &amp; 70H 2WD &amp; 4WD.</b>	Ref.	
1		Shaft Options:	1	
	7011712	0920084 Brake (Prior to S/N 33476)		
	7011712	0920110 Brake (S/N 33476 to S/N 51532)		
	Not Available	0920119 Brake (S/N 57512 to Present)		
2		Guide, Spring Options:	1	
	7011717	0920084 Brake (Prior to S/N 33476)		
	7018606	0920110 Brake (S/N 33476 to S/N 51532)		
	Not Available	0920119 Brake (S/N 57512 to Present)		
3		Spring Options:	A/R	
	7007979	0920084 Brake (Inner) (Prior to S/N 33476)	6	
	7007980	0920084 Brake (Outer) (Prior to S/N 33476)	6	
	7007970	0920110 Brake (Red) (S/N 33476 to S/N 51532)	6	
	7018602	0920110 Brake (Blue) (S/N 33476 to S/N 51532)	3	
	Kit	0920119 Brake (Red) (S/N 57512 to Present)	4	
	Kit	0920119 Brake (Blue) (S/N 57512 to Present)	2	
4		Housing Options:	1	
	7011713	0920084 Brake (Prior to S/N 33476)		
	7018605	0920110 Brake (S/N 33476 to S/N 51532)		
	Not Available	0920119 Brake (S/N 57512 to Present)		
5		Return Plate & Separator Assembly Options:	A/R	
	Kit	Return, Plate - 0920084 Brake (Prior to S/N 33476)	1	
	7011715	Separator Assy - 0920084 Brake (Prior to S/N 33476)	2	
	7011714	Pin	4	
	7007983	Separator	2	
	Kit	Return Plate & Separator - 0920110 Brake (S/N 33476 to S/N 51532)	1	
	Kit	Return Plate & Separator - 0920119 Brake (S/N 57512 to Present)		
6	Kit	Rotor	2	
7	Kit	Stator	2	
8	Kit	Seal, Case	1	
9		Bolt, Washer Head Options:	4	
	7007985	0920084 Brake (Prior to S/N 33476)		
	7018607	0920110 Brake (S/N 33476 to S/N 51532)		
	Not Available	0920119 Brake (S/N 57512 to Present)		
10		Cover Options:	1	
	7007986	0920084 Brake (Prior to S/N 33476)		
	7007986	0920110 Brake (S/N 33476 to S/N 51532)		
	Not Available	0920119 Brake (S/N 57512 to Present)		

# SECTION 1 FRAME

**FIGURE 1-14. BRAKE ASSEMBLY - MICO (CONTINUED)**

FIG & ITEM #	PART NUMBER	DESCRIPTION	QTY.	REV.
11		Hardware Options:	1	
	7000796	Screw, Bleeder (Prior to S/N 33906)		
	7018609	Plug, Pipe (S/N 33906 to S/N 51532)		
	Not Required	S/N 57512 to Present		
12		Pin, Dowel Options:	2	
	7007987	0920084 Brake (Prior to S/N 33476)		
	7007987	0920110 Brake (S/N 33476 to S/N 51532)		
	Not Available	0920119 Brake (S/N 57512 to Present)		
13	Kit	Seal, Oil	1	
14		Ring, Retaining Options:	1	
	7011716	0920084 Brake (Prior to S/N 33476)		
	7011716	0920110 Brake (S/N 33476 to S/N 51532)		
	Kit	0920119 Brake (S/N 57512 to Present)		
15	Kit	Bearing	1	
16		Ring, Retaining	1	
	7007977	0920084 Brake (Prior to S/N 33476)		
	7007977	0920110 Brake (S/N 33476 to S/N 51532)		
	Kit	0920119 Brake (S/N 57512 to Present)		
17	Kit	Ring, Back-Up	1	
18	Kit	Ring, Back-Up	1	
19	Kit	O-Ring	1	
20	Kit	O-Ring	1	
21		Piston Options:	1	
	7007923	0920084 Brake (Prior to S/N 33476)		
	7018603	0920110 Brake (S/N 33476 to S/N 51532)		
	Not Available	0920119 Brake (S/N 57512 to Present)		
22	7007933	Gasket	2	
23	Kit	O-Ring	2	
24	7007924	Plug, Pipe	1	
-----				
		Repair Kits:		
		0920084 Brake (Prior to S/N 33476)		
	2900766	Seal Kit (Includes Items 8,13,17,18,19,20,22 & 23)	1	
	2900768	Seal Kit (Includes Items 8,13,15,22 & 23)	1	
	2900767	Lining Kit Options: (Includes Items 5,6,7,8,22 & 23)	1	
		0920110 Brake (S/N 33476 to S/N 51532)		
	2900766	Seal Kit (Includes Items 8,13,17,18,19,20,22 & 23)	1	
	2900768	Seal Kit (Includes Items 8,13,15,22 & 23)	1	
	7018608	Lining Kit Options: (Includes Items 5,6,7,8,22 & 23)	1	
		0920119 (S/N 57512 to Present)		
	7018612	Complete Repair Kit (Includes Items 5,6,7,8,13, 17, 18,19,20,22 & 23)	1	

# SECTION 1 FRAME

FIGURE 1-14. BRAKE ASSEMBLY - MICO (CONTINUED)

FIG & ITEM #	PART NUMBER	DESCRIPTION	QTY.	REV.

**S  
E  
C  
T  
I  
O  
N  
  
1  
  
F  
R  
A  
M  
E**

# SECTION 1 FRAME

FIGURE 1-15. GEAR REDUCER ASSEMBLY (2WD REAR)

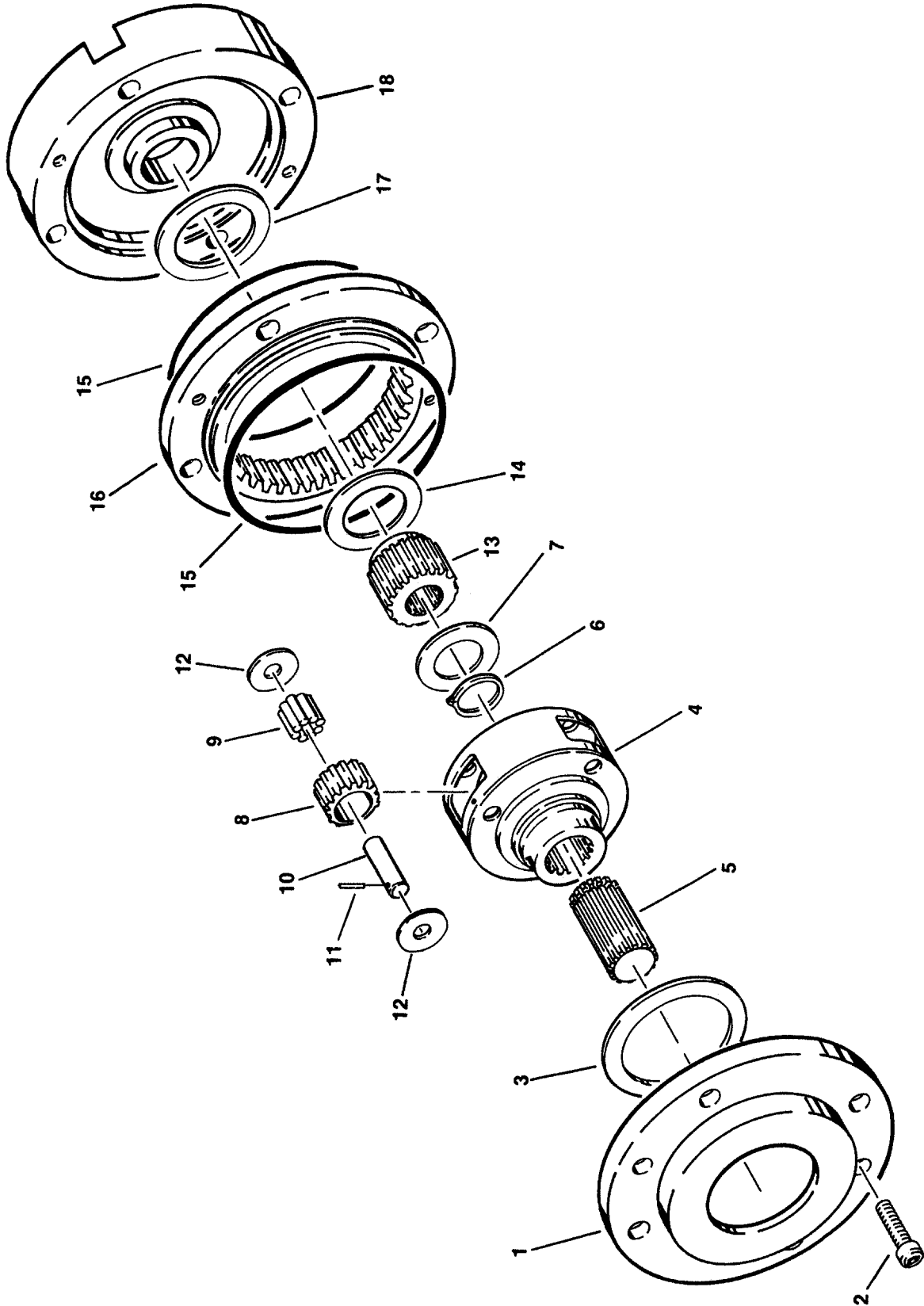

# SECTION 1 FRAME

**FIGURE 1-15. GEAR REDUCER ASSEMBLY (2WD REAR)**

FIG & ITEM #	PART NUMBER	DESCRIPTION	QTY.	REV.
	2780138	<b>GEAR REDUCER ASSEMBLY (2WD REAR)</b> <b>Note: Used with Vickers Valves and Vickers Motors built 1987 to May 1992.</b>	Ref.	A
1	7007663	Hub	1	
2	7007678	Bolt	2	
3	7007673	Washer, Thrust	1	
	7007665	Carrier Sub-Assembly	1	
4		Carrier Options:	1	
	7007666	Carrier (For straight spline shaft)		
	7010498	Carrier (For staggered spline shaft)		
5		Shaft (Output) Options:	1	
	7007672	Straight Spline		
	7010497	Staggered Spline		
6	7000285	Ring, Retaining	1	
7	7000270	Washer, Thrust	1	
8	7007671	Gear (Planet)	3	
9	7007668	Roller, Needle	57	
10	7007670	Shaft (Planet)	3	
11	7007669	Pin, Spring	3	
12	7007667	Washer, Thrust	6	
13	7007676	Gear (Input)	1	
14	7007675	Washer, Thrust	1	
15	7007677	O-Ring	2	
16	7007664	Gear, Ring	1	
17	7000253	Washer, Thrust	1	
18	7007674	Cover	1	
	7007679	Plug, Pipe (Not Shown)	3	

# SECTION 1 FRAME

FIGURE 1-16. HUB ASSEMBLIES

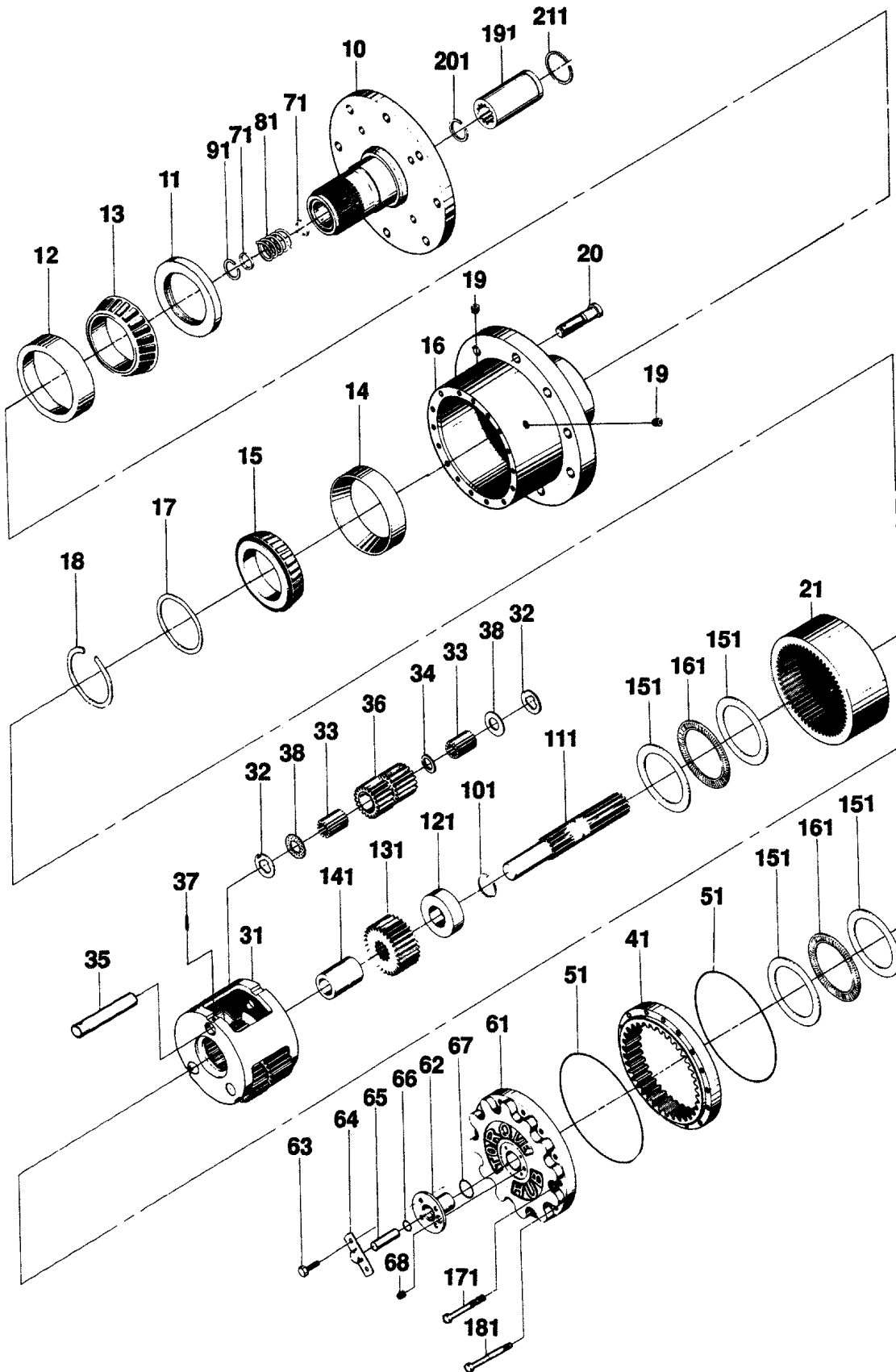

# SECTION 1 FRAME

**FIGURE 1-16. HUB ASSEMBLIES**

FIG & ITEM #	PART NUMBER	DESCRIPTION	QTY.	REV.
		<b>HUB ASSEMBLIES</b>	Ref.	
		<b>Note: Refer to Tire and Wheel Drive Installation for usage.</b>		
	2780052	<b>HUB ASSEMBLY - 18.75:1 RATIO (WITH TAPPED HUB MOUNTING HOLES)</b>	Ref.	A
	2780145	<b>HUB ASSEMBLY - 18.75:1 RATIO (USED WITH TAPPED FRAME MOUNTING HOLES)</b>	Ref.	-
	2780140	<b>HUB ASSEMBLY - 24:1 RATIO (WITH TAPPED HUB MOUNTING HOLES)</b>	Ref.	B
	2780142	<b>HUB ASSEMBLY - 24:1 RATIO (USED WITH TAPPED FRAME MOUNTING HOLES)</b>	Ref.	-
	2780110	<b>HUB ASSEMBLY - 30:1 RATIO</b>	Ref.	-
	2780135	<b>HUB ASSEMBLY - 35:1 RATIO (4WD FRONT)</b>	Ref.	A
	2780040	<b>HUB ASSEMBLY - 35:1 RATIO (4WD REAR)</b>	Ref.	D
	2780136	<b>HUB ASSEMBLY - 43:1 RATIO</b>	Ref.	A
	2780114	<b>HUB ASSEMBLY - 53.58:1 RATIO</b>	Ref.	A
	2780144	<b>HUB ASSEMBLY - 54:1</b>	Ref.	-
	2780187	<b>HUB ASSEMBLY - 73:1</b>	Ref.	A
		<b>HUB SPINDLE ASSEMBLIES</b>	Ref.	
10	7000291	Spindle (2780052 Hub)	1	
	Use 7007656	Spindle (2780145 Hub) (was p/n 7007695)	1	
	7002021	Spindle (2780140 Hub)	1	
	7007656	Spindle (2780142 Hub)	1	
	7001937	Spindle (2780110 and 2780114 Hubs)	1	
	Use 7010464	Spindle (2780135, 2780136 and 2780144 Hubs) (was p/n 7007644)	1	
	7010464	Spindle (2780040 and 2780187 Hubs)	1	
11	Kit	Seal	1	
12	Use 90202500	Cup, Bearing (was p/n 7000272)	1	
13	Use 90202501	Cone, Bearing (was p/n 7000273)	1	
14	7000274	Cup, Bearing	1	
15	Use 90202503	Cone, Bearing (was p/n 7000275)	1	
16	7000276	Hub	1	
17	Kit	Spacer	1	
18	Kit	Ring, Retaining	1	
19	7001928	Plug, Pipe	2	
20	7000265	Stud	10	
		Internal Gear Options:	Ref.	
21	7000277	Gear, Internal (2780052, 2780145, 2780140, 2780142, 2780110, 2780135 and 2780040 Hubs)	1	
	7001917	Gear, Internal (2780136, 2780114 and 2780144 Hubs)	1	
	7010466	Gear, Internal (2780187 Hub)	1	
	7001933	Carrier Assembly (2780052, 2780145 and 2780110 Hubs)	Ref.	
	Use 7000278	Carrier Assembly (2780140, 2780142 and 2780135 Hubs) (was p/n 7007659)	Ref.	
	7007694	Carrier Assembly (2780136 Hub)	Ref.	

# SECTION 1 FRAME

**FIGURE 1-16. HUB ASSEMBLIES (CONTINUED)**

FIG & ITEM #	PART NUMBER	DESCRIPTION	QTY.	REV.
	7001918	Carrier Assembly (2780114 and 2780144 Hubs)	Ref.	
	N/A	Carrier Assembly (2780187 Hub)	Ref.	
31	7001900	Carrier	1	
32	Kit	Washer, Thrust	6	
	7007645	Washer, Thrust (2780187 Hub)	6	
33	7001902	Roller, Needle	84	
34	Kit	Spacer	3	
	7007646	Washer, Thrust (2780187 Hub)	3	
35	7001904	Shaft, Pinion	3	
36	Kit	Gear, Cluster	3	
	7010465	Gear, Cluster (2780187 Hub)	3	
37	7001906	Rollpin	3	
38	Kit	Washer, Thrust (2780052, 2780145, 2780140, 2780142 and 2780135 Hubs)	6	
	Not Required	Washer, Thrust (2780110, 2780040 and 2780114 Hubs)	0	
	7007648	Washer, Thrust (2780136, 2780144 and 2780187 Hubs)	6	
		Ring Gear Options:	Ref.	
41	7000299	Gear, Ring (2780052, 2780145 and 2780110 Hubs)	1	
	Use 7010467	Gear, Ring (2780140, 2780142, 2780135, 2780040, 2780136, 2780114, 2780144 and 2780187 Hubs) (was p/n 7000279)	1	
51	Kit	O-Ring	2	
	Use 7000218	Cover Assembly (was p/n 7000280)	Ref.	
61	7000218	Cover	1	
62	Kit	Cap, Cover	1	
63	7000220	Bolt	4	
64	Kit	Cap, Disconnect	1	
65	Kit	Rod, Disconnect	1	
66	Kit	O-Ring	1	
67	Kit	O-Ring	1	
68	Use 2200201	Plug (was p/n 7000243)	1	
71	7000282	Washer	2	
81	7000283	Spring	1	
91	7000284	Ring, Retaining	1	
101	7000285	Ring, Retaining	1	
		Input Shaft Options:	Ref.	
111	7000292	Shaft, Input (2780052, 2780145, 2780140 and 2780142 Hubs)	1	
	7000222	Shaft, Input (2780110, 2780135, 2780040, 2780114, 2780144 and 2780187 Hubs)	1	
	7007649	Shaft, Input (2780136 Hub)	1	



# SECTION 1 FRAME

**FIGURE 1-16. HUB ASSEMBLIES (CONTINUED)**

FIG & ITEM #	PART NUMBER	DESCRIPTION	QTY.	REV.
121	7000293	Thrust Spacer Options: Spacer, Thrust (2780052, 2780145, 2780140, 2780142 and 2780136 Hubs)	Ref. 1	
	7000286	Spacer, Thrust (2780110, 2780135, 2780040, 2780114 and 2780144 Hubs)	1	
	Use 7000286	Spacer, Thrust (2780187 Hub) (was p/n 7010468)		
131		Input Gear Options:	Ref.	
	7000294	Gear, Input (2780052, 2780145, 2780140 and 2780142 Hub)	1	
	7001939	Gear, Input (2780110 Hub)	1	
	7000221	Gear, Input (2780135, 2780040, 2780114, 2780144 and 2780187 Hubs)	1	
	7001940	Gear, Input (2780136 Hub)	1	
141	7000295	Thrust Spacer Options: Spacer, Thrust (2780052, 2780145, 2780140, 2780142 and 2780136 Hubs)	1	
	Not Required	Spacer, Thrust (2780110, 2780135, 2780040, 2780114, 2780144 and 2780187 Hubs)	1	
151	7000287	Washer, Thrust	4	
161	7000288	Bearing, Thrust	2	
171	7000289	Bolt	8	
181	7000225	Bolt, Shoulder	4	
191		Coupling Options:	Ref.	
	7000296	Coupling (2780052, 2780145, 2780140 and 2780142 Hubs)	1	
	7000290	Coupling (2780110, 2780135, 2780040, 2780136, 2780114, 2780144 and 2780187 Hubs)	1	
201	7000297	Ring, Retaining (2780052, 2780145, 2780140 and 2780142 Hubs Only)	1	
211	7000298	Ring, Retaining (2780052, 2780145, 2780140 and 2780142 Hubs Only)	1	
	2900202	Seal Kit (Includes Items 11, 17, 18 and 51)	1	
	2900138	Disconnect and Seal Kit (Includes Items 11, 17, 18, 51, 62 and 64-67)	1	
	7001905	Cluster Gear Kit (Includes Items 32, 33, 36, 37 and 38) (2780052, 2780145 and 2780110 Hubs)	1	
	7001936	Cluster Gear Kit (Includes Items 32 - P/N 7007645, 33 - P/N 7007646, 36 - P/N Kit, 37 and 38 - P/N Kit) (2780140, 2780142, 2780135 and 2780040 Hubs)		
	7001927	Cluster Gear Kit (Includes Items 32, 22, 36, 37 and 38) (2780136, 2780144 and 2780114 Hubs)	1	
	Consult Factory	Cluster, Gear Kit (2780187 Hub)	1	

# SECTION 1 FRAME

FIGURE 1-17. VALVES INSTALLATION (FRAME MOUNTED)

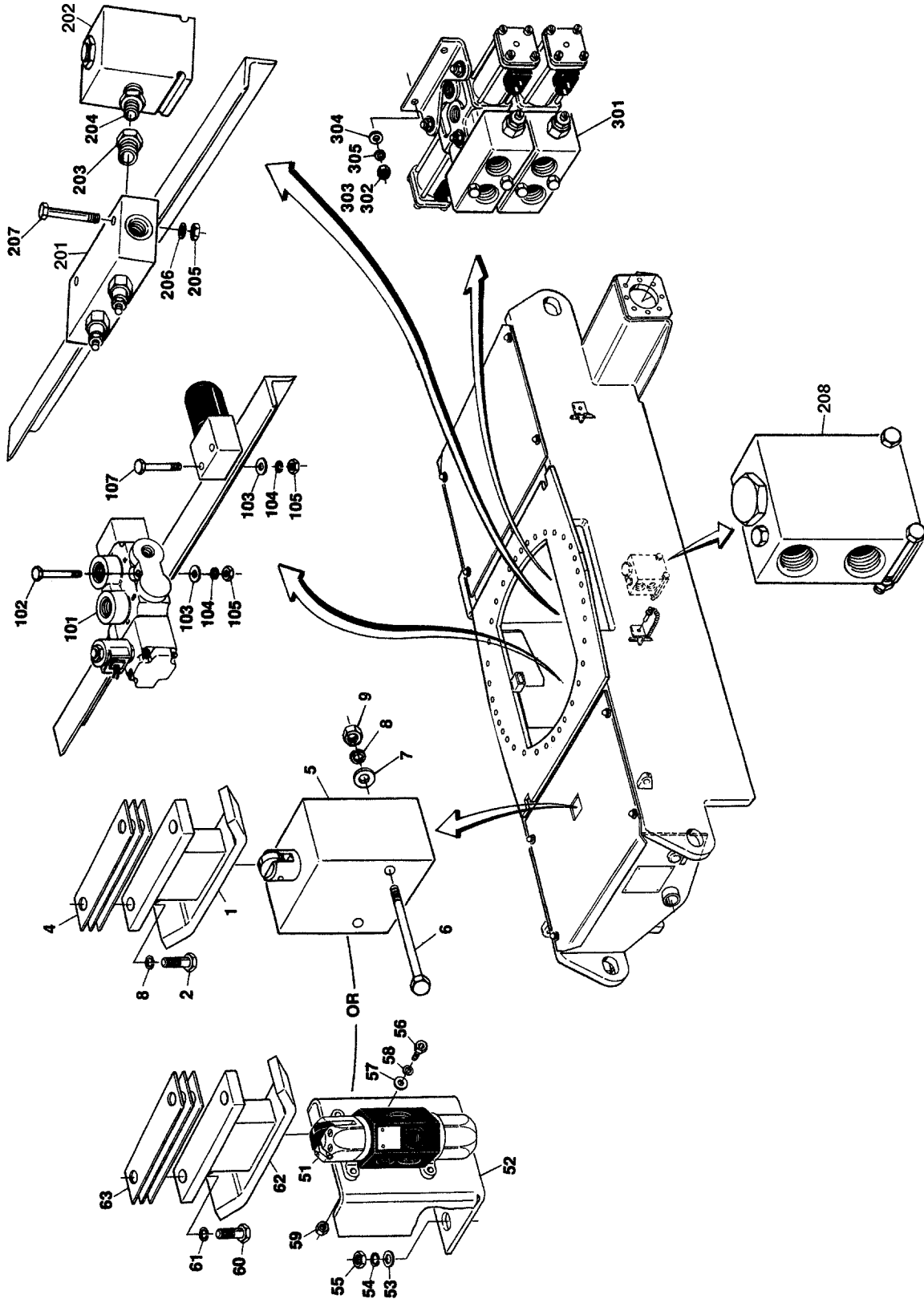

# SECTION 1 FRAME

**FIGURE 1-17. VALVES INSTALLATION (FRAME MOUNTED)**

FIG & ITEM #	PART NUMBER	DESCRIPTION	QTY.	REV.
		<b>VALVES INSTALLATION (FRAME MOUNTED)</b>	Ref.	
	0236404	<b>LOCKOUT VALVE INSTALLATION (OSCILLATING AXLE MACHINES BUILT PRIOR TO MAY 1992)</b>	Ref.	C
1	1100037	Cam Assembly	1	
2	0641612	Bolt 3/8" - 16NC	2	
3	Not Used			
4	4070570	Shim (1/32")	A/R	
	4070571	Shim (1/16")	A/R	
	4070572	Shim (1/8")	A/R	
5	4640485	Valve, Axle Lockout (See Figure 1-18 for Breakdown)	1	
6	0641634	Bolt 3/8"-16NC x 4 1/4"	2	
7	4751600	Flatwasher 3/8"	2	
8	4761600	Lockwasher 3/8"	4	
9	3311601	Nut 3/8"-16NC	2	
	0252386	<b>LOCKOUT VALVE INSTALLATION (OSCILLATING AXLE MACHINES BUILT MAY 1992 TO PRESENT)</b>	Ref.	-
51	4640668	Axle Lockout Valve Assembly	1	
	7012516	Repair Kit	1	
52	0901806	Bracket, Mounting	1	
53	4751500	Flatwasher 5/16"	2	
54	4761500	Lockwasher 5/16"	2	
55	3311501	Nut 5/16"-18NC	2	
56	3931016	Capscrew, Socket Head #10-24NC x 1"	4	
57	4751000	Flatwasher #10	8	
58	4761000	Lockwasher #10	4	
59	3311001	Nut #10-24NC	4	
60	0641612	Bolt 3/8"-16NC x 1 1/2"	2	
61	4761600	Lockwasher 3/8"	2	
62	1100037	Cam, Lockout	1	
63	4070570	Shim (1/32")	A/R	
	4070571	Shim (1/16")	A/R	
	4070572	Shim (1/8")	A/R	
	0236842	<b>2 WHEEL/4 WHEEL DRIVE VALVES INSTALLATION (4WD MACHINES BUILT PRIOR TO MAY 1992)</b>	Ref.	E
101	4640471	Valve	1	
	7004359	Seal Kit	1	
	7010656	Solenoid Cartridge Assembly (Includes Coil)	1	
102	0641524	Bolt 5/16" - 18NC x 3"	2	
103	4751600	Flatwasher 3/8"	4	
104	4761600	Lockwasher 3/8"	4	
105	3311501	Nut 5/16" - 18NC	4	

# SECTION 1 FRAME

**FIGURE 1-17. VALVES INSTALLATION (FRAME MOUNTED) (CONTINUED)**

FIG & ITEM #	PART NUMBER	DESCRIPTION	QTY.	REV.
106	4640363	Solenoid Valve Assembly	1	
	7000558	Coil (FPS Version)	1	
	7001506	Seal Kit (FPS Version)	1	
	7004368	Coil (Hydraforce Version)	1	
	2900795	Seal Kit (Hydraforce Version)	1	
107	0641522	Bolt 5/16" - 18NC x 2 3/4"	2	
		<b>COUNTERBALANCE VALVE AND FLOW DIVIDER INSTALLATIONS</b>	Ref.	
	0236590	<b>ALL MACHINES BUILT PRIOR TO MID 1987 WITH CESSNA MOTORS AND RACINE VALVES</b>	Ref.	-
	0238014	<b>2WD MACHINES BUILT 1987 TO MARCH 1991 WITH VICKERS MOTORS AND VICKERS VALVES</b>	Ref.	-
	0251823	<b>(2WD MACHINES BUILT MARCH 1991 TO MAY 1992 WITH VICKERS MOTORS AND VICKERS VALVES</b>	Ref.	A
	0238014	<b>4WD MACHINES BUILT 1987 TO MARCH 1991 WITH VICKERS MOTOR AND VICKERS VALVES</b>	Ref.	-
	0251824	<b>4WD MACHINES BUILT MARCH 1991 TO MAY 1992 WITH VICKERS MOTORS AND VICKERS VALVES</b>	Ref.	-
	0252576	<b>2WD MACHINES BUILT MAY 1992 TO AUGUST 1993 WITH REXROTH MOTORS AND VICKERS VALVES</b>	Ref.	-
	0254394	<b>2WD MACHINES BUILT AUGUST 1993 TO PRESENT WITH REXROTH MOTOR AND VICKERS VALVES</b>	Ref.	A
	0252577	<b>4WD MACHINES BUILT MAY 1992 TO PRESENT WITH REXROTH MOTORS AND VICKERS VALVES</b>	Ref.	-
201		Dual Counterbalance Valve Assembly Options:	1	
	4640451	Machines Built to Installation p/n 0236590		
	7010630	Cartridge	2	
	4640700	Machines Built to Installations p/n 0238014/0251823/0238014/0251824/0251824/0252576/0254394		
	7011316	Cartridge	2	
		<b>Note: When replacing cartridges on machines built 1987 to March 1991, make sure to use replacement cartridge P/N 7011316 in both locations on valve. Cartridge P/N 7011316 can be identified by the letters "CBGH-LCN" stamped on the hex head. "CGBB-LCN" cannot be used as an equivalent replacement</b>		
	4640700	Machines Built to Installations p/n 0252576 & 0254394 (Machines Built May 1992 to August 1993)		
	7011316	Cartridge	1	
	4640451	Machines Built to Installations p/n 0252576 & 0254394 (Machines Built August 1993 to Present)	1	
	7010630	Cartridge	1	
202	4640682	Machines Built to Installation p/n 0252577		
	7011316	Cartridge	2	
		Flow Divider Assembly Options:	1	
	4640443	Machines Built to Installations p/n 0236590, 0238014, 0251824	1	
	2900745	Seal Kit	1	

# SECTION 1 FRAME

**FIGURE 1-17. VALVES INSTALLATION (FRAME MOUNTED) (CONTINUED)**

FIG & ITEM #	PART NUMBER	DESCRIPTION	QTY.	REV.	
202 (cont'd)	4640260	Machines Built to Installations p/n 0238014, 0251823 & 0252577	1		
	Consult Factory	Cartridge (Vickers/Modular Control Version)	1		
	7009739	Seal Kit (Vickers/Modular Control Version)	1		
	7007321	Cartridge (Fluid Control Version)	1		
	No Longer Available	Seal Kit (Fluid Control Version) (was p/n 7007323)	1		
	4640852	Machines Built to Installations p/n 0252576 & 0254394	1		
		<b>Note: When replacing flow divider on machines built May 1992 to August 1993 use P/N 4640852 instead P/N 4640260 (as equipped).</b>			
	4640841	Cartridge	1		
	203	2220377	Fitting, Straight	1	
	204	2220844	Fitting, Adapter	1	
205	3311501	Nut 5/16"-18NC	A/R		
206	4751500	Flatwasher 5/16"	A/R		
207	0641524	Bolt 5/16"-18NC x 3"	A/R		
208	4640671	Flow Divider Assembly (WD Machines Built May 1992 to Present Only)	1		
	7010510	Cartridge (Vickers/Modular Controls Version)	1		
	7009739	Seal Kit (Vickers/Modular Controls Version)	1		
	Use 70003445	Cartridge (Fluid Controls Version) (was p/n 7007322)	1		
	No Longer Available	Seal Kit (Fluid Controls Version) (was p/n 7007323)	1		
	0252552/ 0252553	<b>CONTROL VALVES INSTALLATION - 4WS OPTION (WITHOUT PROP TELE)</b>	Ref.	C/C	
	0252186/ 0253187	<b>CONTROL VALVES INSTALLATION - 4WS OPTION (WITH PROP TELE)</b>	Ref.	B/B	
301	4640684	Control Valve Assembly (See Figure 1-19 for Break-down)	1		
302	4300038	Stud (Welded on Part)	4		
303	3311501	Nut 5/16"-18NC	4		
304	4751500	Flatwasher 5/16"	4		
305	4761500	Lockwasher 5/16"	4		

# SECTION 1 FRAME

FIGURE 1-18. LOCKOUT VALVE ASSEMBLY

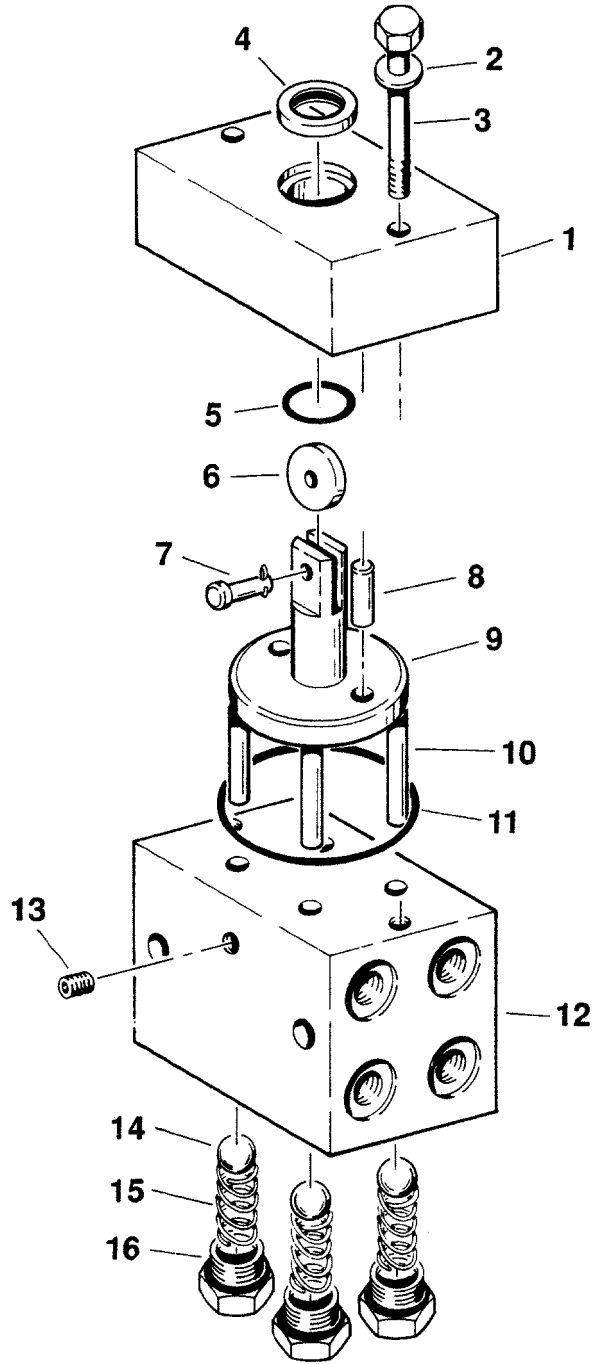

# SECTION 1 FRAME

**FIGURE 1-18. LOCKOUT VALVE ASSEMBLY**

FIG & ITEM #	PART NUMBER	DESCRIPTION	QTY.	REV.
	4640485	<b>LOCKOUT VALVE ASSEMBLY</b> <b>Note: Oscillating Axle Machines Built Prior to May 1992.</b>	Ref.	A
1	0560679	Block, Top Valve	1	
2	0641518	Bolt 5/16"-18NC x 2 1/4"	2	
3	4761500	Lockwasher 5/16"	2	
4	3960047	Seal, Rod	1	
5	3790116	O-Ring	1	
6	3860037	Roller, Cam	1	
7	3430407	Clevis Pin with Cotter Pin	1	
8	3421284	Pin	2	
9	3840833	Plunger, Rod	1	
10	3840854	Rod	4	
11	3790231	O-Ring	1	
12	0560467	Block, Bottom Valve	1	
13	2200202	Plug	1	
	0100011	Loctite	A/R	
14	0320008	Ball	4	
15	4160078	Spring	4	
16	2180658	Plug	4	

# SECTION 1 FRAME

FIGURE 1-19. CONTROL VALVE ASSEMBLY - 2 SECTION BANG-BANG (4WS)

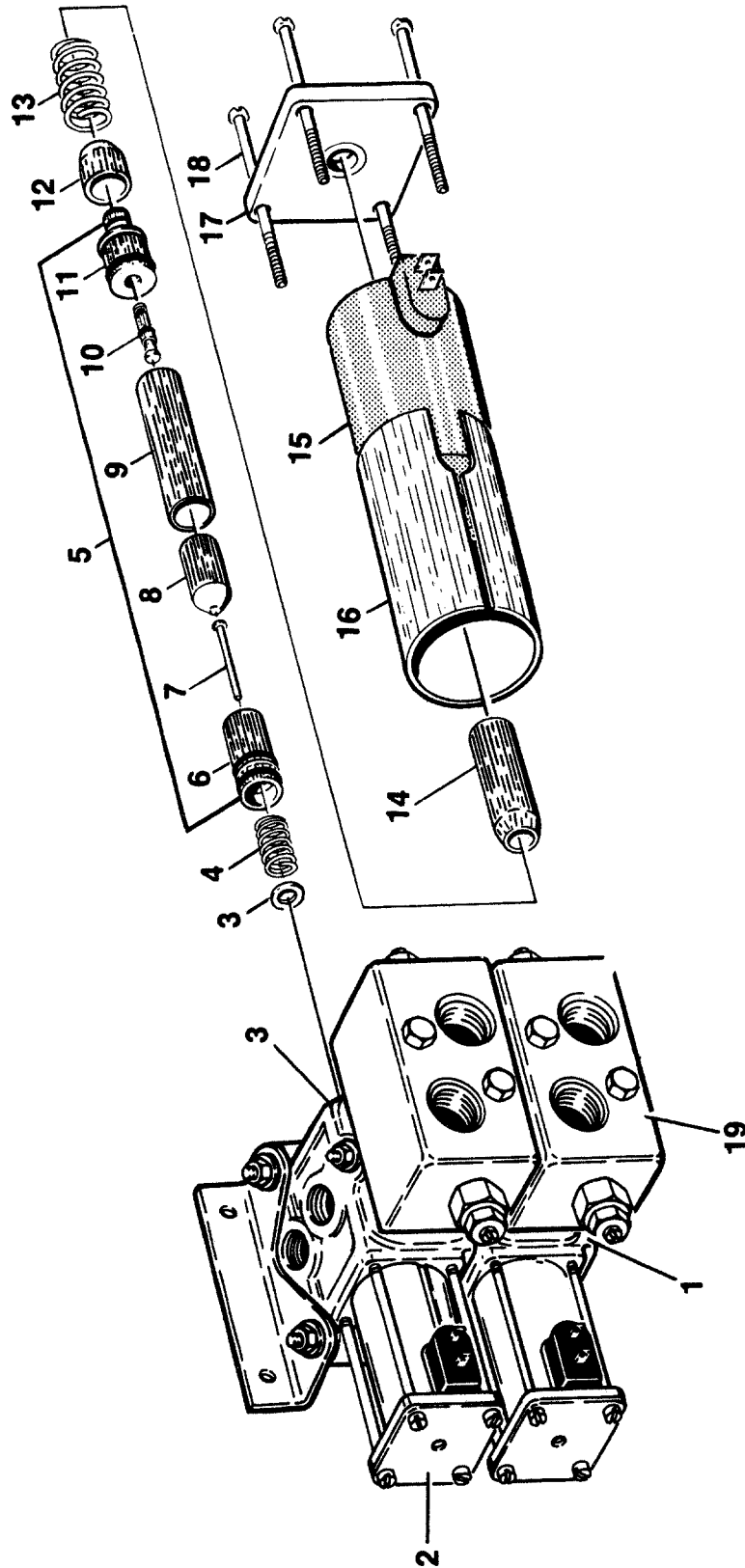



# SECTION 1 FRAME

**FIGURE 1-19. CONTROL VALVE ASSEMBLY - 2 SECTION BANG-BANG (4WS)**

FIG & ITEM #	PART NUMBER	DESCRIPTION	QTY.	REV.
	4640684	<b>CONTROL VALVE ASSEMBLY - 2 SECTION BANG-BANG (4WS)</b>	Ref.	-
1	7002315	Steer Section - Complete (Front and Rear)	2	
2	7004859	Solenoid Assembly	2	
3	7002274	Washer	1	
4	7002348	Spring	1	
5	7002305	Guide Tube Assembly	1	
6	7002345	Cone, Female	1	
	Kit	O-Ring	1	
	Kit	O-Ring	1	
7	7002346	Pin, Push	1	
8	7002344	Plunger	1	
9	7000470	Tube, Guide	1	
10	7002341	Pin, Actuator	1	
	Kit	Ring, Quad	1	
11	7002340	Guide, External Push Pin	1	
	Kit	O-Ring	1	
12	7002333	Sleeve, Inner Flux	1	
13	7002334	Spring	1	
14	7002336	Sleeve, Outer Flux	1	
15	7000418	Coil	1	
16	7002335	Case, Solenoid	1	
17	7002338	Plate, End	1	
	7002327	Nameplate	1	
18	7002339	Screw	4	
19	7000468	Relief Valve Block Assembly (No Longer Field Serviceable)	1	
	7000414	Seal Kit - Working Section	2	

# SECTION 1 FRAME

FIGURE 1-20. TOW PACKAGE INSTALLATIONS

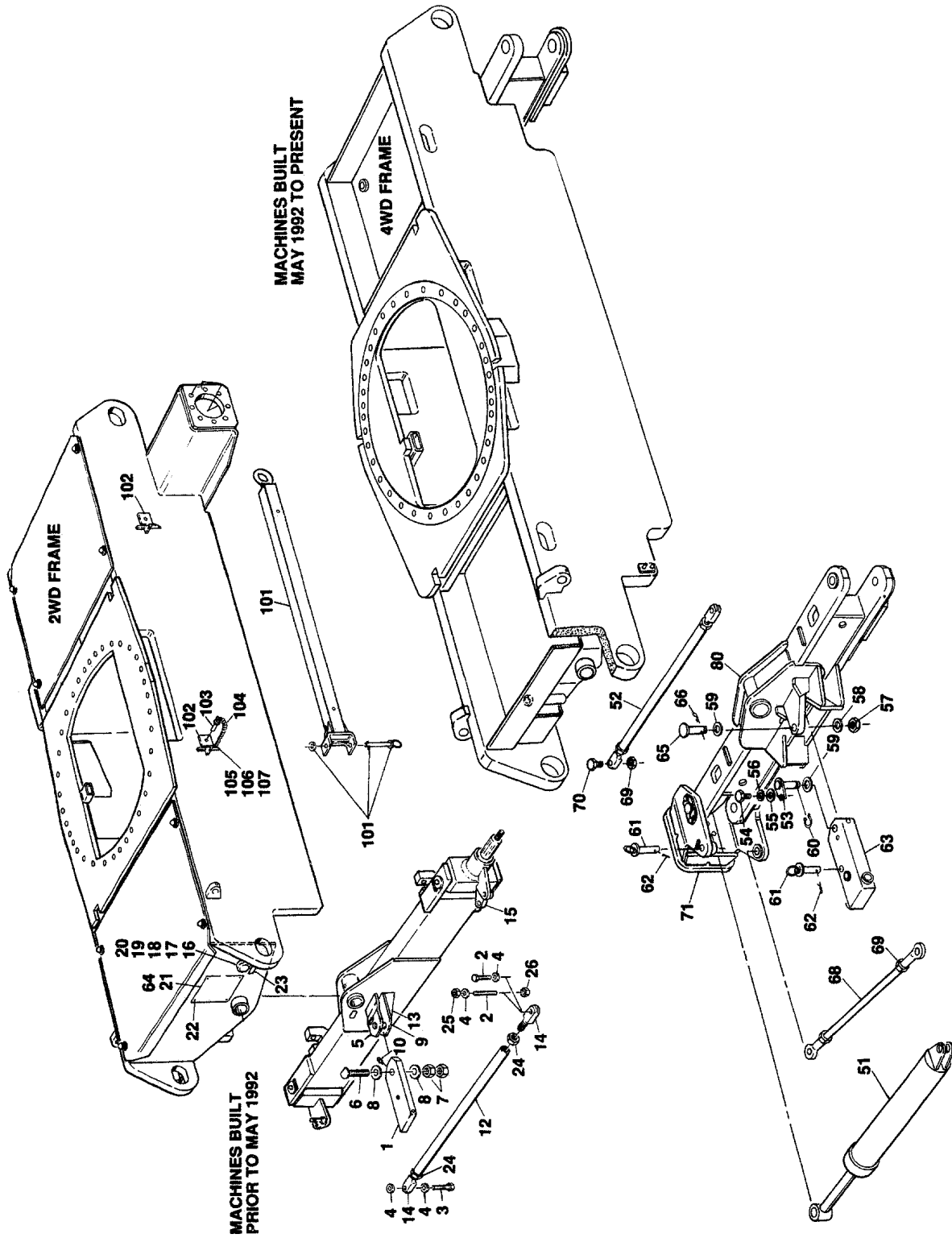

# SECTION 1 FRAME

**FIGURE 1-20. TOW PACKAGE INSTALLATIONS**

FIG & ITEM #	PART NUMBER	DESCRIPTION	QTY.	REV.
		<b>TOW PACKAGE INSTALLATIONS</b> <b>Note: For steering/axle components not called out see Figures 2-1 and 2-2.</b>	Ref.	
	0236966	<b>STEERING COMPONENTS INSTALLATION - 2WD OSCILLATING AXLE MACHINES BUILT PRIOR TO MAY 1992</b>	Ref.	A
	9982255	<b>STEERING COMPONENTS INSTALLATION - 2WD FIXED AXLE MACHINES BUILT PRIOR TO MAY 1992</b>	Ref.	D
	0238185	<b>STEERING COMPONENTS INSTALLATION - 4WD OSCILLATING AXLE MACHINES BUILT PRIOR TO MAY 1992</b>		
1		Hitch Options:	1	
	2620028	2WD Oscillating Axle Machines Built Prior to May 1992		
	2620022	2WD Fixed Axle Machines Built Prior to May 1992		
	2620030	4WD Oscillating Axle Machines Built Prior to May 1992		
2		Hardware Options:	1	
	0642622	Bolt 1"-8NC x 2 3/4" (2WD Oscillating Axle Machines Built Prior to May 1992)		
	9982256	Stud (2WD Fixed Axle Machines Built Prior to May 1992)		
	0642620	Bolt 1"-8NC x 2 1/2" (4WD Oscillating Axle Machines Built Prior to May 1992)		
3		Bolt Options:	1	
	0642624	Bolt 1"-8NC x 3" (2WD Oscillating Axle Machines Built Prior to May 1992)		
	0682628	Bolt 1"-8NC x 3 1/2" (Grade 8) (2WD Fixed Axle Machines Built Prior to May 1992)		
	0642628	Bolt 1"-8NC x 3 1/2" (4WD Oscillating Axle Machines Built Prior to May 1992)		
4		Hardware Options:	A/R	
	4762600	Lockwasher 1" (Machines with Oscillating Axle)	3	
	4562103	Spacer (1/8" Thick) (Machines with Fixed Axle)	2	
	0960268	Spacer (1/2" Thick) (Machines with Fixed Axle)	1	
5		Lug (Top) Options:	1	
	3040326	2WD Oscillating Axle Machines Built Prior to May 1992		
	3040145	2WD Fixed Axle Machines Built Prior to May 1992		
	3531793	4WD Oscillating Axle Machines Built Prior to May 1992		
6		Pin Options:	1	
	3421246	2WD Oscillating Axle Machines Built Prior to May 1992		
	3420860	2WD Fixed Axle Machines Built Prior to May 1992		
	3421151	4WD Oscillating Axle Machines Built Prior to May 1992		

# SECTION 1 FRAME

**FIGURE 1-20. TOW PACKAGE INSTALLATIONS (CONTINUED)**

FIG & ITEM #	PART NUMBER	DESCRIPTION	QTY.	REV.
7		Nut, Jam 1 1/4"-12NF Options:	2	
	3300023	2WD Oscillating Axle Machines Built Prior to May 1992		
	3300023	2WD Fixed Axle Machines Built Prior to May 1992		
	3323004	4WD Oscillating Axle Machines Built Prior to May 1992		
8	4753000	Flatwasher 1 1/4"	2	
9		Lug (Bottom) Options:	1	
	3040327	2WD Oscillating Axle Machines Built Prior to May 1992		
	Not Required	2WD Fixed Axle Machines Built Prior to May 1992		
	3530015	4WD Oscillating Axle Machines Built Prior to May 1992		
10		Fitting, Grease Options:	1	
	2160003	Fitting, Grease - 45° (2WD Oscillating Axle Machines Built Prior to May 1992)		
	2160003	Fitting, Grease - 45° (2WD Fixed Axle Machines Built Prior to May 1992)		
	2160002	Fitting, Grease (4WD Oscillating Axle Machines Built Prior to May 1992)		
11	2880410	Keystock (Not Shown)	1	
12		Tie-Rod Options:	1	
	3840822	Machines Oscillating Axle		
	3840643	Machines Fixed Axle		
13		Gusset Options:	2	
	2550925	2WD Oscillating Axle Machines Built Prior to May 1992		
	Not Required	2WD Fixed Axle Machines Built Prior to May 1992		
	2551050	4WD Oscillating Axle Machines Built Prior to May 1992		
14	1660114	Coupling	2	
15		Lug (Steering Arm) Options:	1	
	3040314	2WD Oscillating Axle Machines Built Prior to May 1992		
	3040314	2WD Fixed Axle Machines Built Prior to May 1992		
	3040381	4WD Oscillating Axle Machines Built Prior to May 1992		
		<b>Note: Items 16-23 Machines with Oscillating Axle Only.</b>		
16	0900479	Bracket, Valve	1	
17	4640261	Select Valve Assembly	1	
18	0641507	Bolt 5/16"-18NC x 7/8"	2	
19	4761500	Lockwasher 5/16"	2	
20	4751500	Flatwasher 5/16"	2	
21	3250840	Nameplate - Caution	1	
22	3820001	Rivet	8	
23	3250872	Nameplate - Tow Select	1	
24		Nut, Special Options:	2	
	3300160	2WD Oscillating Axle Machines Built Prior to May 1992		
	3300160	2WD Fixed Axle Machines Built Prior to May 1992		

# SECTION 1 FRAME

**FIGURE 1-20. TOW PACKAGE INSTALLATIONS (CONTINUED)**

FIG & ITEM #	PART NUMBER	DESCRIPTION	QTY.	REV.
24 (cont'd)	3323002	4WD Oscillating Axle Machines Built Prior to May 1992		
25	Not Required	Nut, 1"-8NC Options:	1	
	3312601	Machines with Oscillating Axle Machines with Fixed Axle		
26	Not Required	Locknut 1"-8NC Options:	1	
	3312605	Machines with Oscillating Axle Machines with Fixed Axle		
	0253189	<b>STEERING COMPONENTS INSTALLATIONS - 60H 2WD MACHINES BUILT MAY 1992 TO PRESENT</b>	Ref.	C
	0253190	<b>STEERING COMPONENTS INSTALLATION - 70H 2WD MACHINES BUILT MAY 1992 TO PRESENT</b>	Ref.	C
	0253177	<b>STEERING COMPONENTS INSTALLATION - 4WD MACHINES BUILT MAY 1992 TO PRESENT</b>	Ref.	C
51		Steer Cylinder Assembly Options (See Section 5 for Breakdown):	1	
	1682780	2WD		
	1681555	4WD		
52		Tie-Rod Options:	1	
	3841149	2WD		
	3841142	4WD		
53	3422106	Pin	2	
54		Bolt Options:	1	
	0641610	Bolt 3/8"-16NC x 1 1/4" (2WD)		
	0641608	Bolt 3/8"-16NC x 1" (4WD)		
55	4751600	Flatwasher 3/8"	1	
56	4761600	Lockwasher 3/8"	1	
57		Locknut 1"-8NC Options:	1	
	3300243	2WD		
	Not Required	4WD		
58	4712600	Flatwasher 1" Narrow	1	
59	4740155	Washer, Thrust	3	
60	3760143	Ring, Retaining	1	
61		Pin Options:	1	
	3422117	2WD		
	3422119	4WD		
62	3420372	Hairpin	1	
63		Hitch Options:	1	
	4844215	2WD		
	4844230	4WD		
64		Decal - Caution Options:	1	
	1701781	2WD - Decal (Prior to May 1994)		
	1702307	2WD - Decal (May 1994 to Present)		
	1701782	4WD - Decal (Prior to May 1994)		
	1702307	4WD - Decal (May 1994 to Present)		
65- 72	Not Shown	<b>Note: Use Standard Parts when required 2WD Machines.</b>	A/R	
65	3431622	Pin, Clevis (4WD Machines Only)	1	

# SECTION 1 FRAME

**FIGURE 1-20. TOW PACKAGE INSTALLATIONS (CONTINUED)**

FIG & ITEM #	PART NUMBER	DESCRIPTION	QTY.	REV.
66	3450606	Pin, Cotter (4WD Machines Only)	1	
67	0642620	Bolt 1" - 8NC x 2 1/2" (4WD Machines Only)	1	
68	1660114	Tie-Rod (4WD Machines Only)	1	
69	3312602	Nut, Jam 1"-8NC (4WD Machines Only)	3	
70	0630425	Bolt, Special (4WD Machines Only)	1	
71	4130294	Spindle (RH) (Use Standard Spindle for Left Side) (4WD Machines Only)	1	
72	3780187	O-Ring (Not Shown - Located near Kingpin) (June 1994 to Present) (4WD Machines Only)	4	
	0253188	<b>FRONT AXLE INSTALLATION - MACHINES BUILT MAY 1992 TO PRESENT ONLY (2WD FIXED AXLE)</b>	Ref.	B
	0253191	<b>FRONT AXLE INSTALLATION - MACHINES BUILT MAY 1992 TO PRESENT ONLY (2WD OSCILLATING AXLE)</b>	Ref.	A
	0253706	<b>FRONT AXLE INSTALLATION - MACHINES BUILT MAY 1992 TO PRESENT ONLY (4WD)</b> <b>Note: Machines built prior to May 1992 use standard axle with welded on parts called out in 1- 49 series numbers.</b>	Ref.	A
80		Axle Weldment Options:	1	
	4844231	2WD Axle		
	0961613	Bushing, Bronze	2	
	4844366	4WD Axle (May 1992 to June 1994)		
	0961613	Bushing, Bronze (Axle Pivot)	2	
	0961614	Bushing, Bronze (Kingpin)	4	
	4844809	4WD Axle (June 1994 to Present)		
	0961613	Bushing, Bronze (Axle Pivot)	2	
	0961850	Bushing, Bronze (Kingpin)	4	
	0236880	<b>TOW BAR ASSEMBLY AND STOWAGE INSTALLA- TION (FIXED AXLE BUILT PRIOR TO MAY 1992)</b>	Ref.	-
	0236968	<b>TOW BAR ASSEMBLY AND STOWAGE INSTALLA- TION (OSCILLATING AXLE BUILT PRIOR TO MAY 1992)</b>	Ref.	-
	0253196	<b>TOW BAR ASSEMBLY AND STOWAGE INSTALLA- TION (60H BUILT MAY 1992 TO PRESENT)</b>	Ref.	-
	0253197	<b>TOW BAR ASSEMBLY AND STOWAGE INSTALLA- TION (70H BUILT MAY 1992 TO PRESENT)</b>	Ref.	-
101	0232121	Tow Bar Assembly	1	
	3420447	Pin, Tow	1	
	4740036	Flatwasher, Special	1	
	3420372	Pin, Cotter	1	
102	4841055	Mount, Stowage	2	
103	3420292	Pin, Quick Release	2	
104	1260017	Chain (2PC x 4")	8"	
105	4300031	Stud (Welded on Part)	2	
106	4751400	Flatwasher 1/4"	2	
107	3311405	Locknut 1/4"-20NC	2	

# SECTION 2 TURNTABLE

<b>TABLE OF CONTENTS</b>		
<b>FIGURE</b>	<b>DESCRIPTION</b>	<b>PAGE</b>
2-1	BOOM, TURNTABLE & BEARING LUBE INSTALLATIONS . . . . .	2-4
2-2	CONTROL VALVE INSTALLATION - RACINE PROPORTIONAL . . . . .	2-8
2-3	RACINE PROPORTIONAL CONTROL VALVE ASSEMBLY - OUTLET SECTION . . . . .	2-14
2-4	RACINE PROPORTIONAL CONTROL VALVE ASSEMBLY - WORKING SECTION . . . . .	2-16
2-5	RACINE PROPORTIONAL CONTROL VALVE ASSEMBLY - INLET SECTION . . . . .	2-18
2-6	RACINE PROPORTIONAL CONTROL VALVE ASSEMBLY - SERVO SECTION . . . . .	2-22
2-7	CONTROL VALVE INSTALLATION - VICKERS PROPORTIONAL . . . . .	2-26
2-8	VICKERS PROPORTIONAL CONTROL VALVE ASSEMBLY (Prior to October 1994) . . . . .	2-34
2-9	VICKERS PROPORTIONAL CONTROL VALVE ASSEMBLY (Standard Controls) (October 1994 to Present) . . . . .	2-38
2-10	VICKERS PROPORTIONAL CONTROL VALVE ASSEMBLY (Hydraulic Controls) (October 1994 to Present) . . . . .	2-42
2-11	CONTROL VALVE ASSEMBLY - BANG-BANG WITH DUMP SECTION . . . . .	2-46
2-12	CONTROL VALVE ASSEMBLY - BANG-BANG WITH DUMP SECTION . . . . .	2-50
2-13	CONTROL VALVE ASSEMBLY - BANG-BANG WITH INLET RELIEF . . . . .	2-54
2-14	CONTROL VALVE ASSEMBLY - 1 SECTION BANG-BANG (4WS) . . . . .	2-58
2-15	STEERING VALVE ASSEMBLY . . . . .	2-60
2-16	ACCESSORY VALVE ASSEMBLY (Miller) . . . . .	2-62
2-17	ACCESSORY VALVE ASSEMBLY . . . . .	2-64
2-18	SWING, DRIVE, BEARING & LOCK INSTALLATION . . . . .	2-66
2-19	SWING MOTOR ASSEMBLY . . . . .	2-70
2-20	SWING BRAKE ASSEMBLY (Prior to April 1992) . . . . .	2-72
2-21	SWING BRAKE ASSEMBLY (April 1992 to Present) . . . . .	2-76
2-22	SWING HUB ASSEMBLY . . . . .	2-80
2-23	ROTARY COUPLING & COLLECTOR RING ASSEMBLY INSTALLATION . . . . .	2-82
2-24	DEUTZ ENGINE INSTALLATION WITHOUT NOISE REDUCTION (Built Prior to December 1992) . . . . .	2-86
2-25	DEUTZ ENGINE INSTALLATION WITH NOISE REDUCTION (Built December 1992 to Present) . . . . .	2-96
2-26	ADECO THROTTLE COMPONENTS INSTALLATION - Deutz Engine Machines . . . . .	2-104
2-27	GENERATOR INSTALLATION - Deutz Engine Machines . . . . .	2-108
2-28	FORD LSG-423 ENGINE INSTALLATIONS (Prior to February 1995) . . . . .	2-112
2-29	ADECO THROTTLE INSTALLATION - Ford Engine Machines Built Prior to Mid 1987 . . . . .	2-124
2-30	PRECISION GOVERNOR INSTALLATION - Ford Engine Machines Built Mid 1987 to February 1995 . . . . .	2-128
2-31	GENERATOR INSTALLATION - Ford Engine Machines Built Prior to February 1995 . . . . .	2-130
2-32	FORD LSG-423 ENGINE INSTALLATIONS (February 1995 to Present) . . . . .	2-134
2-33	110VOLT GENERATOR INSTALLATIONS - Ford Engine Machines Built February 1995 to Present . . . . .	2-142
2-34	DUAL FUEL INSTALLATION - Ford Engine Machines . . . . .	2-146
2-35	PUMP COUPLING INSTALLATIONS . . . . .	2-150
2-36	WISCONSIN ENGINE INSTALLATION . . . . .	2-154
2-37	MAIN PUMP ASSEMBLY (Machines With Racine Proportional Valves) . . . . .	2-160
2-38	MAIN PUMP ASSEMBLY (Machines With Vickers Proportional Valves Built Prior to Mid 1987 - Has One Outlet in End Cover) . . . . .	2-164
2-39	MAIN PUMP ASSEMBLY (Machines With Vickers Proportional Valves Built Mid 1987 to Present - Has One Outlet in End Cover) . . . . .	2-166

# SECTION 2 TURNTABLE

## SECTION 2 TURNTABLE

### TABLE OF CONTENTS

FIGURE	DESCRIPTION	PAGE
2-40	TANKS INSTALLATIONS .....	2-168
2-41	LP TANKS INSTALLATIONS .....	2-174
2-42	GROUND CONTROL COMPONENTS INSTALLATION (Machines With Racine Proportional Valves .....	2-178
2-43	GROUND CONTROL COMPONENTS INSTALLATION (Machines With Vickers Proportional Valves .....	2-182
2-44	GROUND CONTROL COMPONENTS INSTALLATION (Machines With Hydraulic Controls) . .	2-188
2-45	ELECTRICAL COMPONENTS INSTALLATION (Turntable Mounted) .....	2-194
2-46	HOODS INSTALLATION (Machines Built Prior to December 1992) .....	2-198
2-47	HOODS INSTALLATION (Machines Built December 1992 to Present) .....	2-202



# SECTION 2 TURNTABLE

TABLE OF CONTENTS		
FIGURE	DESCRIPTION	PAGE

**S  
E  
C  
T  
I  
O  
N  
  
2  
  
T  
U  
R  
N  
T  
A  
B  
L  
E**

# SECTION 2 TURNTABLE

FIGURE 2-1. BOOM, TURNTABLE AND BEARING LUBE INSTALLATIONS

SECTION 2 TURNTABLE

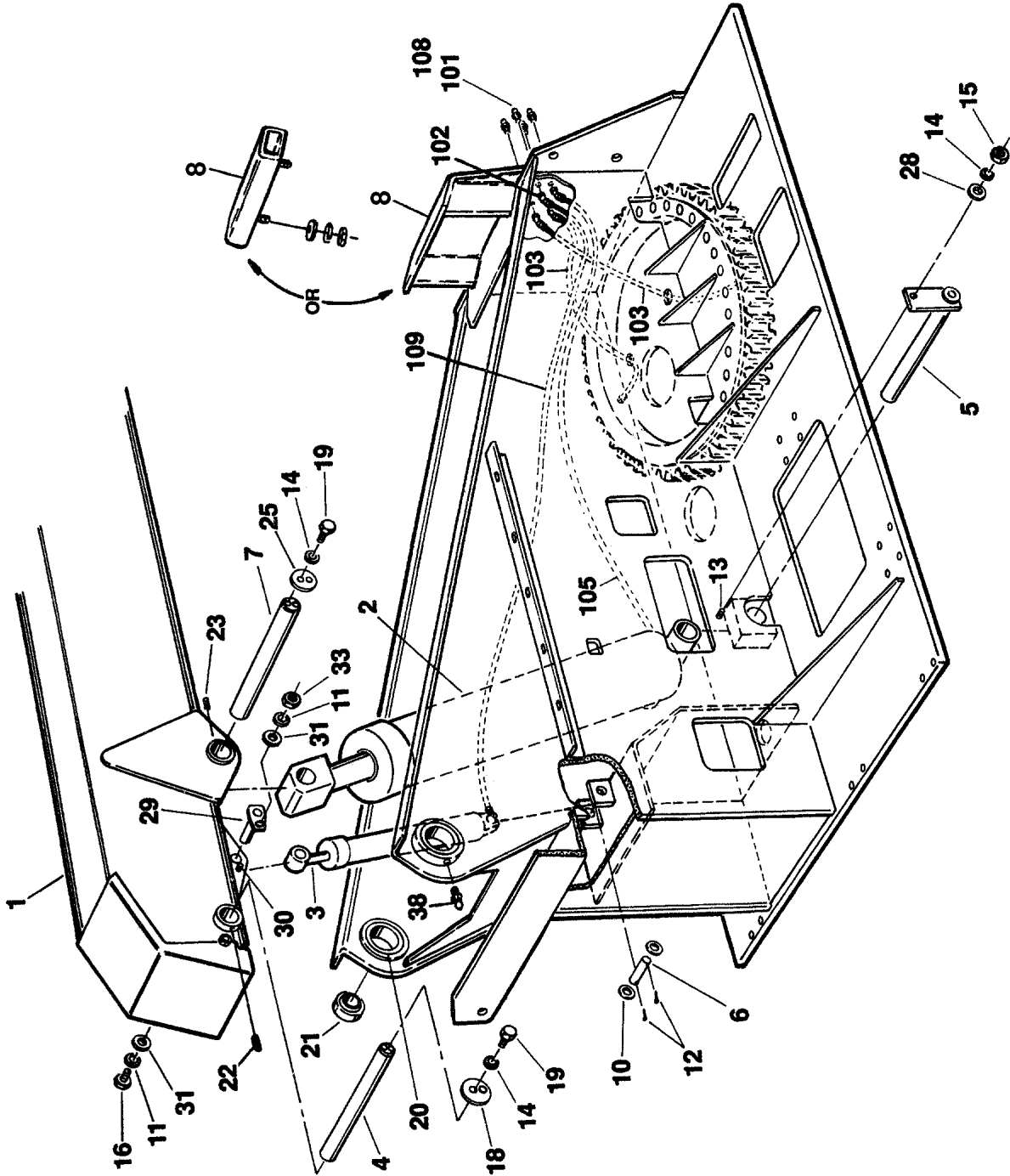

# SECTION 2 TURNTABLE

**FIGURE 2-1. BOOM, TURNTABLE AND BEARING LUBE INSTALLATIONS**

FIG & ITEM #	PART NUMBER	DESCRIPTION	QTY.	REV.
		<b>BOOM, TURNTABLE AND BEARING LUB INSTALLATIONS</b>	Ref.	
	4620014	Turntable Weldment (Prior to December 1992)	1	
	4620087	Turntable Weldment (December 1992 to Present)	1	
	0236438	<b>BOOM INSTALLATION - STANDARD 60H</b>	Ref.	M
	0251654	<b>BOOM INSTALLATION - 750 LBS CAP 60H</b>	Ref.	E
	0239213	<b>BOOM INSTALLATION - HYDRAULIC CONTROLS 60H</b>	Ref.	D
	0251481	<b>BOOM INSTALLATION - CSA 60H</b>	Ref.	E
	0255564	<b>BOOM INSTALLATION - CSA HYDRAULIC CONTROLS 60H</b>	Ref.	A
	0237995	<b>BOOM INSTALLATION - STANDARD 60H+6</b>	Ref.	F
	0251483	<b>BOOM INSTALLATION - CSA 60H+6</b>	Ref.	D
	0237122	<b>BOOM INSTALLATION - STANDARD 70H</b>	Ref.	G
	0250336	<b>BOOM INSTALLATION - HYD CONTROLS 70H</b>	Ref.	G
1		Boom Assembly Options (See Section 3 for Break-down):	1	
	0800392	Standard 60H		
	0800392	Standard 60H - 750Lbs Capacity		
	0800577	Hydraulic Controls 60H		
	0800392	Standard 60H - CSA		
	0800577	Hydraulic Controls 60H - CSA		
	0800505	Standard 60H+6		
	0800505	Standard 60H+6 - CSA		
	0800418	Standard 70H		
	0800418	Hydraulic Controls 70H		
2	1681513	Lift Cylinder Assembly (Machines Built Prior to May 1992) (See Section 5 for Breakdown)	1	
	1682599	Lift Cylinder Assembly - TUV (Machines Built May 1992 to Present) (See Section 5 for Breakdown)	1	
3	1681580	Master Level Cylinder Assembly (See Section 5 for Breakdown)	1	
4		Pin (Boom Pivot) Options:	1	
	4040129	Standard/Hydraulic Controls		
	3421815	Standard 60H - 750Lbs Capacity		
	3421815	Standard/Hydraulic Controls - CSA		
5	4040126	Pin (Lift Cylinder Lower)	1	
6	3420085	Pin (Master Level Cylinder Lower)	1	
7	3421144	Pin (Lift Cylinder Upper)	1	
8		Boom Rest Weldment (Bolt-on) Options:	1	
	4842814	Standard/Hydraulic Controls - 60H/60H+6		
	4841885	Standard/Hydraulic Controls - 70H		
9	Not Used			
10	4740040	Flatwasher 1 1/4"	2	
11	4761600	Lockwasher 3/8"	2	
12	3450608	Pin, Cotter 3/16" x 2"	2	
13	4300045	Stud (Welded on Part)	2	

# SECTION 2 TURNTABLE

**FIGURE 2-1. BOOM, TURNTABLE AND BEARING LUBE INSTALLATIONS (CONTINUED)**

FIG & ITEM #	PART NUMBER	DESCRIPTION	QTY.	REV.
14	4761800	Lockwasher 1/2"	10	
15	3311805	Locknut 1/2" - 13NC	2	
16	0651608	Bolt 3/8"-24NF x 1"	1	
17	4740006	Flatwasher 7/16"	1	
18	1120192	Cap, Boom Pivot	2	
19	0681810	Bolt 1/2" - 13NC x 1 1/4" (Grade 8)	8	
20	2760075	Housing, Bearing (Part of Turntable Weldment)	2	
21	0960562	Bushing, Self Aligning (Part of Turntable Weldment)	2	
22	3952014	Setscrew 5/8"-11NC x 1 3/4"	2	
23	3900017	Setscrew 1/2"-20NF x 1"	1	
24	0100011	Loctite #242 (Not Shown)	A/R	
25	4740277	Flatwasher, Special	2	
26	Not Used			
27	Not Used			
28	4751800	Flatwasher 1/2"	2	
29	0236548	Pin (Master Level Cylinder Upper)	1	
30	4300034	Stud (Welded on Part)	1	
31	4751600	Flatwasher 3/8"	1	
32	Not Used			
33	3311601	Nut 3/8"-16NC	1	
34	0100019	Loctite #271 (Not Shown)	A/R	
35	Not Used			
36	Not Used			
37	Not Used			
38	2160006	Fitting, Grease	2	
	0236431	<b>BEARING LUBRICATION INSTALLATION</b>	Ref.	C
101	2160002	Fitting, Grease	4	
102	2220124	Fitting, 45°	4	
103	2751032	Hose	2	
104	Not Used			
105	2750527	Hose	1	
106	Not Used			
107	Not Used			
108	2180344	Fitting, Bulkhead	4	
109	2752427	Hose	1	

**SECTION 2 TURNTABLE**

# SECTION 2 TURNTABLE

FIGURE 2-1. BOOM, TURNTABLE AND BEARING LUBE INSTALLATIONS (CONTINUED)

FIG & ITEM #	PART NUMBER	DESCRIPTION	QTY.	REV.

**S  
E  
C  
T  
I  
O  
N  
  
2  
  
T  
U  
R  
N  
T  
A  
B  
L  
E**

# SECTION 2 TURNTABLE

FIGURE 2-2. CONTROL VALVES INSTALLATION - RACINE PROPORTIONAL

SECTION 2 TURNTABLE

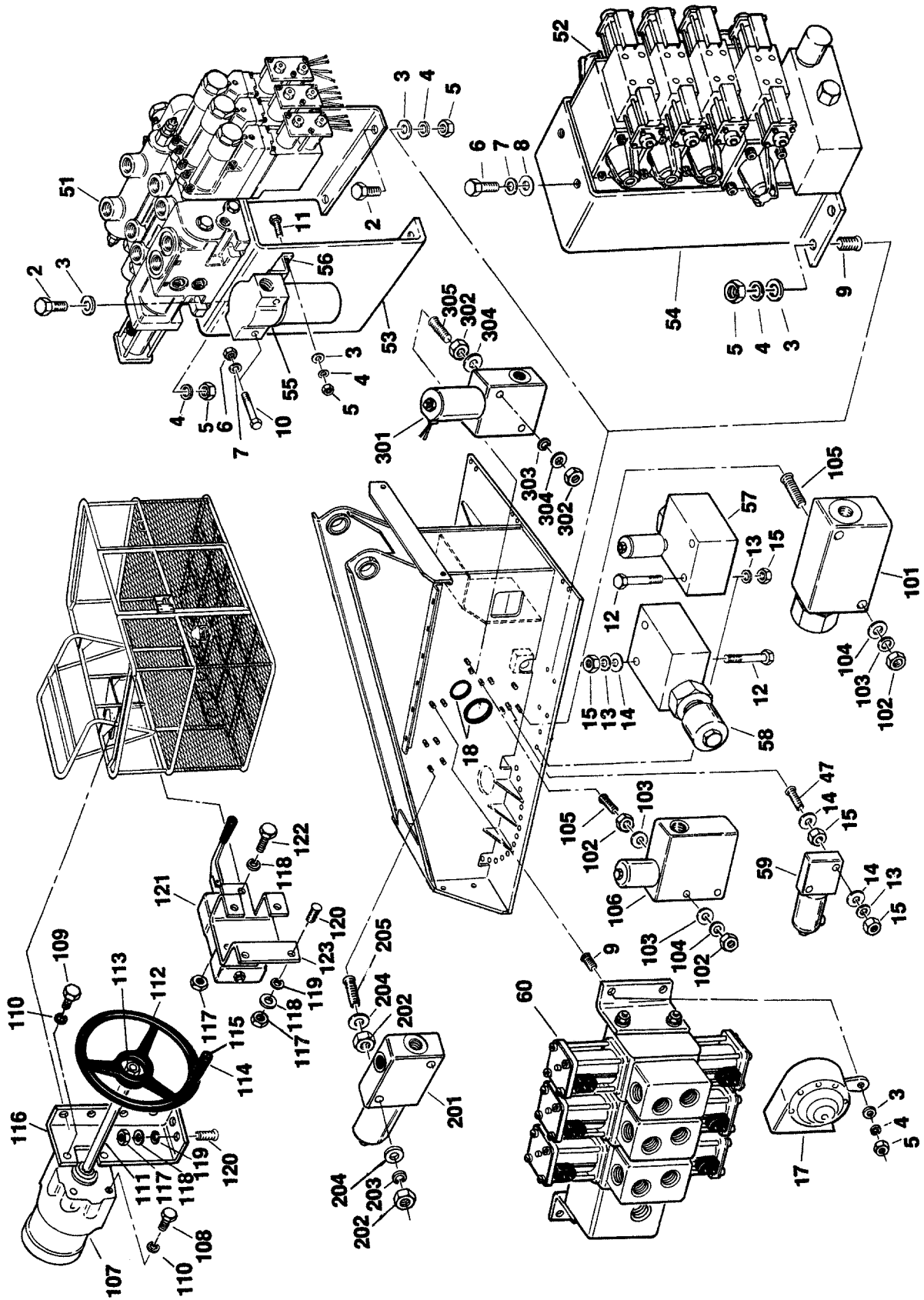

# SECTION 2 TURNTABLE

**FIGURE 2-2. CONTROL VALVES INSTALLATION - RACINE PROPORTIONAL**

FIG & ITEM #	PART NUMBER	DESCRIPTION	QTY.	REV.
		<b>CONTROL VALVES INSTALLATION - RACINE PROPORTIONAL</b>	Ref.	
		<b>CONTROL VALVES INSTALLATION (STANDARD PARTS)</b>	Ref.	
1	Not Used			
2	0641612	Bolt 3/8"-16NC x 1 1/2"	A/R	
3	4751600	Flatwasher 3/8"	A/R	
4	4761600	Lockwasher 3/8"	A/R	
5	3311601	Nut 3/8"-16NC	A/R	
6	0641408	Bolt 1/4"-20NC x 1"	A/R	
7	4761400	Lockwasher 1/4"	A/R	
8	4751400	Flatwasher 1/4"	A/R	
9	4300034	Stud (Welded on Part)	A/R	
10	0641420	Bolt 1/4"-20NC x 2 1/2"	A/R	
11	0641609	Bolt 3/8"-16NC x 1 1/8"	A/R	
12	0641528	Bolt 5/16"-18NC x 3 1/2"	A/R	
13	4761500	Lockwasher 5/16"	A/R	
14	4751500	Flatwasher 5/16"	A/R	
15	3311501	Nut 5/16" - 18NC	A/R	
16	4300033	Stud (Welded on Part)	A/R	
17	0140001	Horn	1	
18	4060608	Flex-Guard	3.4 ft.	
		<b>CONTROL VALVES INSTALLATION FOR MACHINES WITH GEAR PUMP (VARIABLE PARTS):</b>	Ref.	
	0236360	Valves Installation - with Prop Tele/With Rotate/Without Steering Wheel	Ref.	
	0236361	Valves Installation - With Prop Tele/Without Rotate/Without Steering Wheel	Ref.	
	0236362	Valves Installation - Without Prop Tele/With Rotate/Without Steering Wheel	Ref.	
	0236363	Valves Installation - Without Prop Tele/Without Rotate/Without Steering Wheel	Ref.	
	0236621	Valves Installation - Without Prop Tele/With Rotate/With Steering Wheel	Ref.	
	0236622	Valves Installation - With Prop Tele/With Rotate/With Steering Wheel	Ref.	
	0236623	Valves Installation - Without Prop Tele/Without Rotate/With Steering Wheel	Ref.	
	0236624	Valves Installation - With Prop Tele/Without Rotate/With Steering Wheel	Ref.	
		<b>CONTROL VALVES INSTALLATION FOR MACHINES WITH PISTON PUMP (VARIABLE PARTS):</b>	Ref.	
	0236742	Valves Installation - Without Prop Tele/With Rotate/With Steering Wheel	Ref.	

**SECTION 2 TURNTABLE**

# SECTION 2 TURNTABLE

**FIGURE 2-2. CONTROL VALVES INSTALLATION - RACINE PROPORTIONAL (CONTINUED)**

FIG & ITEM #	PART NUMBER	DESCRIPTION	QTY.	REV.
	0236752	<b>Valves Installation - With Prop Tele/With Rotate/ Without Steering Wheel</b>	Ref.	
	0236753	<b>Valves Installation - With Prop Tele/With Rotate/ With Steering Wheel</b>	Ref.	
51		Racine Control Valve Options: Machines With Gear Pump	1	
	4640456	Control Valve Assembly - 4 Section (See Figure 2-3 for Breakdown)		
	4640455	Control Valve Assembly - 3 Section (See Figure 2-3 for Breakdown)		
	Not Required	Machines With Piston Pump		
52		HPI/Nichols Control Valve Options:	1	
	Not Required	Machines With Gear Pump		
		Machines With Piston Pump		
	4640465	Control Valve Assembly - 3 Section		
	4640466	Control Valve Assembly - 4 Section		
53		Bracket, Mounting Options:	1	
	0901157	Bracket, Mounting (Machines With Gear Pump)		
	Not Required	Machines With Piston Pump		
54		Bracket, Mounting Options:	1	
	Not Required	Machines With Gear Pump		
	0901318	Bracket, Mounting (Machines With Piston Pump)		
55		Filter Assembly Options:	1	
	2120078	Filter Assembly (Machines With Gear Pump)		
	2120079	Element	1	
	Not Required	Machines With Piston Pump		
56		Bracket, Filter Options:	1	
	0901159	Bracket, Filter (Machines With Gear Pump)		
	Not Required	Machines With Piston Pump		
57		Solenoid Valve Assembly Options:	1	
	4640136	Machines With Gear Pump		
	4640136	Solenoid Valve Assembly		
	7000522	Solenoid Cartridge Assembly (With Coil)	1	
	7000548	Coil	1	
	7007320	Adjustable Cartridge Assembly	1	
	7001507	Seal Kit - 4640136 Valve	1	
	Not Required	Machines With Piston Pump		
58		Solenoid Valve Assembly Options:	1	
	Not Required	Machines With Gear Pump		
	4640464	Solenoid Valve Assembly (Machines With Piston Pump)		
	7009742	Coil	1	
	2900737	Seal Kit	1	
59		Solenoid Valve Assembly Options:	1	
	Not Required	Machines With Gear Pump		
	4640123	Solenoid Valve Assembly (Machines With Piston Pump)		
	7004368	Coil (Hydraforce Version)	1	
	7012518	Seal Kit (Hydraforce Version)	1	

**SECTION 2 TURNTABLE**



# SECTION 2 TURNTABLE

**FIGURE 2-2. CONTROL VALVES INSTALLATION - RACINE PROPORTIONAL (CONTINUED)**

FIG & ITEM #	PART NUMBER	DESCRIPTION	QTY.	REV.
59 (cont'd)	7000558	Coil (FPS Version)	1	
	7006075	Seal Kit (FPS Version)	1	
60		Bang-Bang Control Valve Options:	1	
	4640247	4 Section Valve (See Figure 2-11 for Break-down)		
	4640246	3 Section Valve (See Figure 2-11 for Break-down)		
	4640447	2 Section Valve (With Rotate) (See Figure 2-13 for Breakdown)		
	4640462	2 Section Valve (Without Rotate) (See Figure 2-11 for Breakdown)		
	4640461	1 Section Valve (See Figure 2-13 for Breakdown)		
		<b>CONTROL VALVES INSTALLATION FOR MACHINES WITH PISTON PUMP (VARIABLE PARTS):</b>	Ref.	
	0236742	<b>Valves Installation - Without Prop Tele/With Rotate/With Steering Wheel</b>	Ref.	
	0236752	<b>Valves Installation - With Prop Tele/With Rotate/Without Steering Wheel</b>	Ref.	
	0236753	<b>Valves Installation - With Prop Tele/With Rotate/With Steering Wheel</b>	Ref.	
51	Not Required			
52		HPI/Nichols Control Valve Options:	1	
	4640465	Control Valve Assembly - 3 Section		
	4640466	Control Valve Assembly - 4 Section		
53	Not Required			
54	0901318	Bracket, Mounting	1	
55	Not Required			
56	Not Required			
57	Not Required			
58	4640464	Solenoid Valve Assembly	1	
	7009742	Coil	1	
	2900737	Seal Kit	1	
59	4640123	Solenoid Valve Assembly	1	
	7004368	Coil (Hydraforce Version)	1	
	7012518	Seal Kit (Hydraforce Version)	1	
	7000558	Coil (FPS Version)	1	
	7006075	Seal Kit (FPS Version)	1	
60		Bang-Bang Control Valve Options:	1	
	4640247	4 Section Valve (See Figure 2-11 for Break-down)		
	4640246	3 Section Valve (See Figure 2-11 for Break-down)		
	4640447	2 Section Valve (With Rotate) (See Figure 2-13 for Breakdown)		
	4640462	2 Section Valve (Without Rotate) (See Figure 2-11 for Breakdown)		
	4640461	1 Section Valve (See Figure 2-13 for Breakdown)		

# SECTION 2 TURNTABLE

**FIGURE 2-2. CONTROL VALVES INSTALLATION - RACINE PROPORTIONAL (CONTINUED)**

FIG & ITEM #	PART NUMBER	DESCRIPTION	QTY.	REV.
		<b>CONTROL VALVES INSTALLATION - WITH OPTIONAL STEERING WHEEL</b>	Ref.	
101	4640151	Flow Divider Assembly	1	
102	3311501	Nut 5/16"-18NC	A/R	
103	4751500	Flatwasher 5/16"	A/R	
104	4761500	Lockwasher 5/16"	A/R	
105	4300033	Stud (Welded on Part)	A/R	
106	4640360	Dump Valve Assembly	1	
	7009745	Coil (Vickers/Modular Controls Version)	1	
	7004289	Solenoid Cartridge Less Coil (Vickers/Modular Controls Version)	1	
	7003635	Check Valve Cartridge (Vickers/Modular Controls Version)	1	
	7004368	Coil (Hydraforce Version)	1	
	7012910	Solenoid Cartridge Less Coil (1989 to Present) (Hydraforce Version)	1	
	7010635	Solenoid Cartridge Less Coil (Prior to 1989) (Hydraforce Version)	1	
	7009798	Check Valve Cartridge (Hydraforce Version)	1	
107	4640408	Steer Valve Assembly (See Figure 2-15 for Break-down)	1	
108	0641606	Bolt 3/8" - 16NC x 3/4"	2	
109	0641608	Bolt 3/8"- 16NC x 1"	2	
110	4761600	Lockwasher 3/8"	4	
111	1460005	Column, Steering	1	
112	4860097	Wheel, Steering	1	
113	3300073	Nut, Special	1	
114	2560066	Knob	1	
115	3900060	Bolt, Shoulder	1	
116	0901255	Bracket, Steer Valve	1	
117	3311401	Nut 1/4"-20NC	12	
118	4761400	Lockwasher 1/4"	12	
119	4751400	Flatwasher 1/4"	12	
120	4300031	Stud (Welded on part)	10	
121	4640434	Rotate Valve Assembly	1	
122	0641416	Bolt 1/4"-20NC x 2"	2	
123	0901416	Bracket, Rotate Valve	1	
	0236649	<b>SHUTDOWN VALVE INSTALLATION</b>	Ref.	
201	4640123	Solenoid Valve Assembly	1	
	7004368	Coil (Hydraforce Version)	1	
	7012518	Seal Kit (Hydraforce Version)	1	
	7000558	Coil (FPS Version)	1	
	7006075	Seal Kit (FPS Version)	1	
202	3311501	Nut 5/16"-18NC	4	
203	4761500	Lockwasher 5/16"	2	
204	4751500	Flatwasher 5/16"	4	
205	4300033	Stud (Welded on Part)	2	

**SECTION 2 TURNTABLE**

# SECTION 2 TURNTABLE

**FIGURE 2-2. CONTROL VALVES INSTALLATION - RACINE PROPORTIONAL (CONTINUED)**

FIG & ITEM #	PART NUMBER	DESCRIPTION	QTY.	REV.
	0236677	<b>TWO SPEED DRIVE VALVE INSTALLATION</b>	Ref.	-
301	4640123	Solenoid Valve Assembly	1	
	7004368	Coil (Hydraforce Version)	1	
	7012518	Seal Kit (Hydraforce Version)	1	
	7000558	Coil (FPS Version)	1	
	7006075	Seal Kit (FPS Version)	1	
302	3311501	Nut 5/16" - 18NC	4	
303	4761500	Lockwasher 5/16"	2	
304	4751500	Flatwasher 5/16"	2	
305	4300033	Stud (Welded on Part)	2	

SECTION 2 TURNTABLE

# SECTION 2 TURNTABLE

FIGURE 2-3. RACINE PROPORTIONAL CONTROL VALVE ASSEMBLY - OUTLET SECTION.

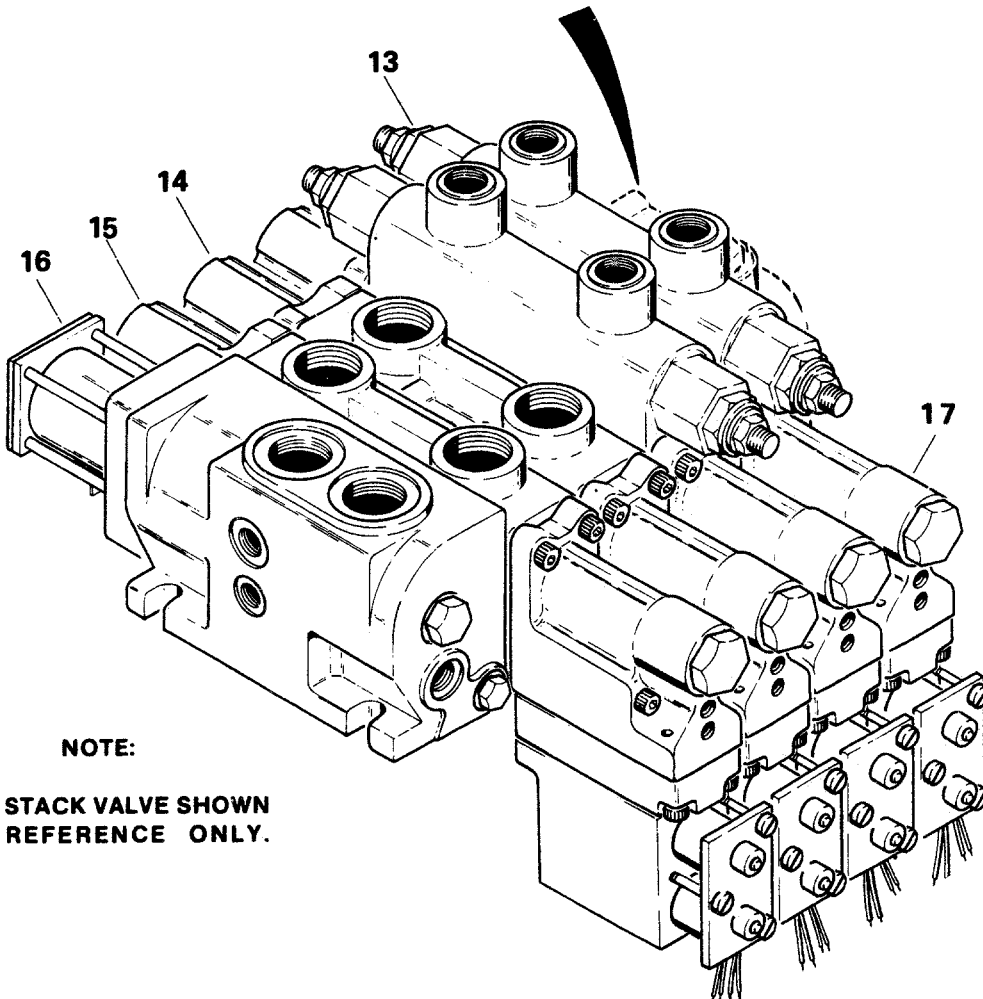
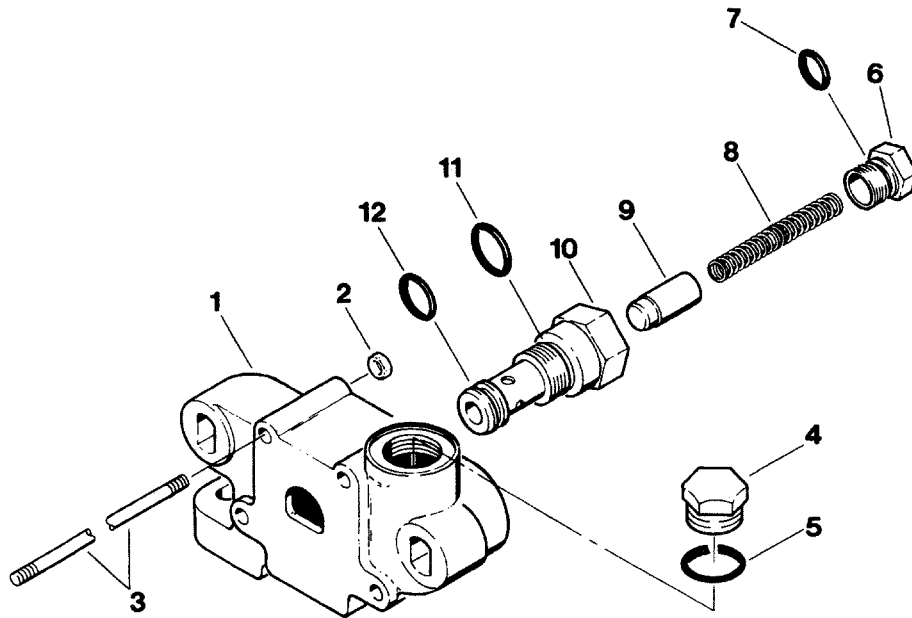

NOTE:

FOUR STACK VALVE SHOWN FOR REFERENCE ONLY.

SECTION 2 TURNTABLE

# SECTION 2 TURNTABLE

**FIGURE 2-3. RACINE PROPORTIONAL CONTROL VALVE ASSEMBLY - OUTLET SECTION.**

FIG & ITEM #	PART NUMBER	DESCRIPTION	QTY.	REV.
	4640455	<b>RACINE PROPORTIONAL CONTROL VALVE ASSEMBLY - OUTLET SECTION (3 SECTION)</b>	Ref.	-
	4640456	<b>RACINE PROPORTIONAL CONTROL VALVE ASSEMBLY - OUTLET SECTION (4 SECTION)</b>	Ref.	-
1	7004885	Outlet Section (3 Section Valve) (Includes Items 4-12)	1	
	7002368	Outlet Section (4 Section Valve) (Includes Items 4-12)	1	
2	7004869	Nut	4	
3	7004870	Stud	4	
4	7004871	Plug	1	
5	Kit	O-Ring	1	
		-----		
	7004872	Cartridge Assembly, Pilot Pressure	1	
	7002288	Plug and O-Ring Assembly	1	
6	7004873	Plug	1	
7	Kit	O-Ring	1	
8	7004874	Spring	1	
9	7002287	Poppet	1	
10	7004875	Housing	1	
11	Kit	O-Ring	1	
12	Kit	O-Ring	1	
13	7004891	Swing and Telescope Valve Sections (See Figure 2-4 for Breakdown)	1	
14	7004888	Lift Valve Section (See Figure 2-4 for Breakdown)	1	
15	7004890	Drive Valve Section (See Figure 2-4 for Breakdown)	1	
16	7002364	Inlet Manifold (See Figure 2-5 for Breakdown)	1	
17	7004884	Servo Assembly (See Figure 2-6 for Breakdown)	1	
		-----		
	7004833	Seal Kit - 7004885 Outlet Section (Includes Items 5, 7, 11 and 12) (4 Section Valve)	1	

**SECTION 2 TURNTABLE**

# SECTION 2 TURNTABLE

FIGURE 2-4. RACINE PROPORTIONAL CONTROL VALVE ASSEMBLY

SECTION 2 TURNTABLE

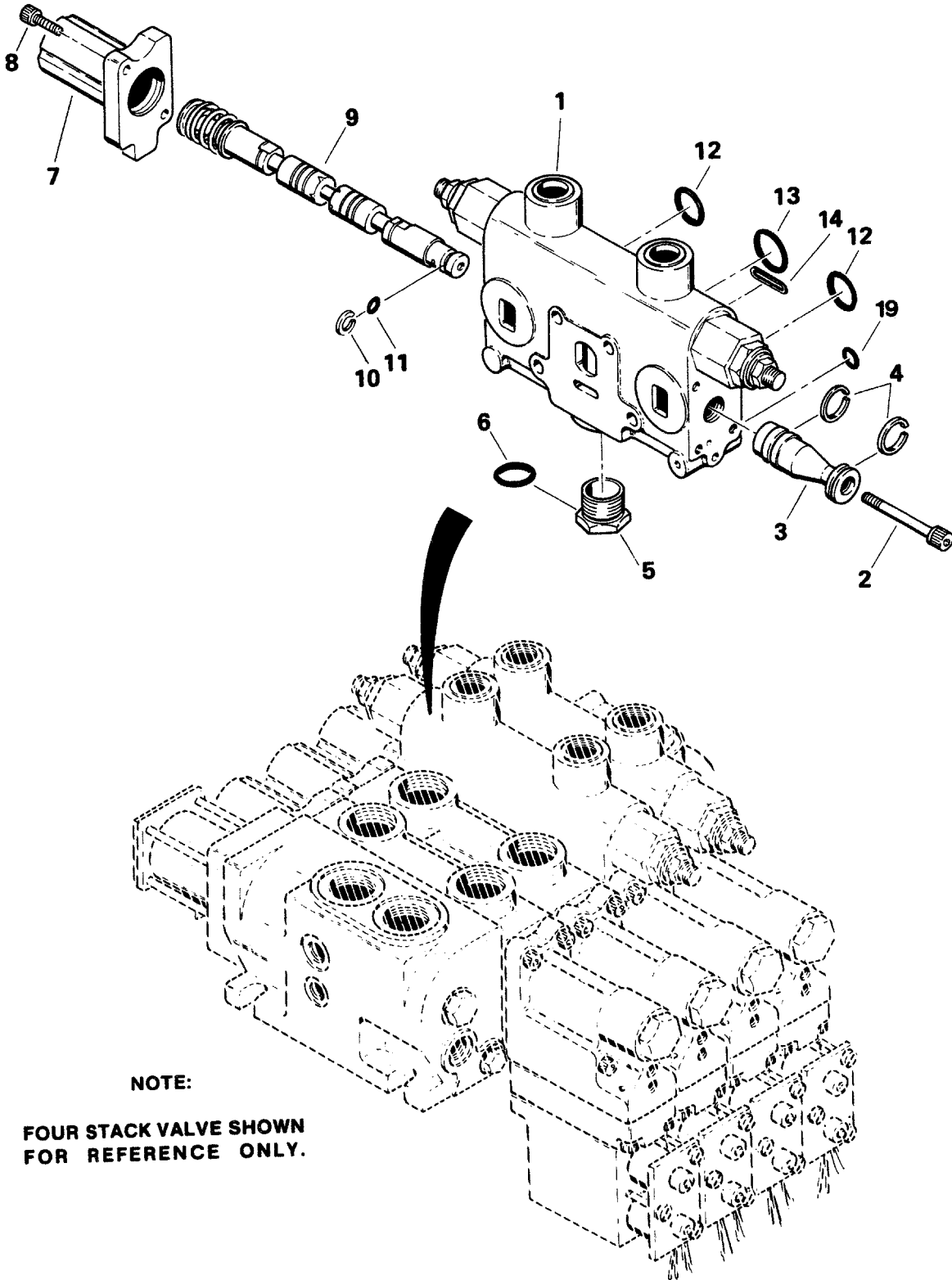

# SECTION 2 TURNTABLE

**FIGURE 2-4. RACINE PROPORTIONAL CONTROL VALVE ASSEMBLY**

FIG & ITEM #	PART NUMBER	DESCRIPTION	QTY.	REV.
		<b>RACINE PROPORTIONAL CONTROL VALVE ASSEMBLY</b>	Ref.	
	7004888	<b>LIFT VALVE SECTION (INCLUDING SERVO ASSEMBLY)</b>	Ref.	
	7004891	<b>SWING VALVE SECTION (INCLUDING SERVO ASSEMBLY)</b>	Ref.	
	7004891	<b>TELESCOPE VALVE SECTION (INCLUDING SERVO ASSEMBLY) (4 SECTION VALVE ONLY)</b>	Ref.	
	7004890	<b>DRIVE VALVE SECTION (INCLUDING SERVO ASSEMBLY)</b>	Ref.	
1		Valve Body (Not Serviced - Purchase Complete Assembly)	1	
2	7002391	Screw, Socket Head	1	
3	7004808	Ramp (Supplied with Servo)	Ref.	
4	7002233	Ring (Supplied with Servo)	Ref.	
5	7004802	Plug Assembly	1	
6	Kit	O-Ring	1	
7	7002398	Cap End	1	
8	7002231	Screw, Socket Head	2	
9	7004805	Spool, Lift Section	1	
	7004807	Spool, Swing Section	1	
	4140010	Spool, Drive Section	1	
10	Kit	Ring, Piston	1	
11	Kit	O-Ring	1	
12	Kit	O-Ring	2	
13	Kit	O-Ring	1	
14	Kit	O-Ring	1	
15	7002378	O-Ring	1	
		-----		
	7004832	Seal Kit (Includes Items 6, 10, 11,12, 13 and 14)	4	

SECTION 2 TURNTABLE

# SECTION 2 TURNTABLE

FIGURE 2-5. RACINE PROPORTIONAL CONTROL VALVE ASSEMBLY - INLET (DUMP) SECTION

SECTION 2 TURNTABLE

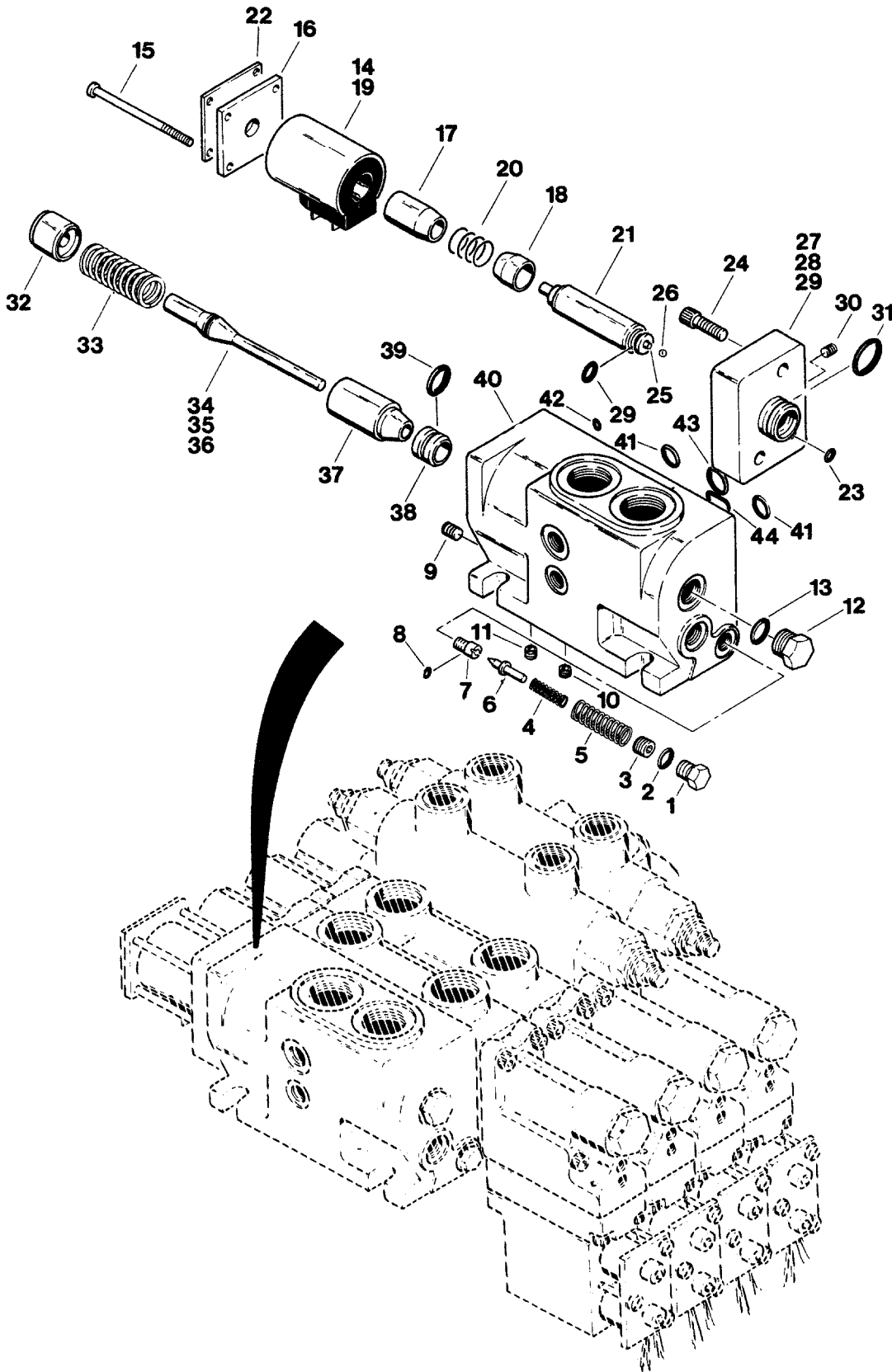



# SECTION 2 TURNTABLE

**FIGURE 2-5. RACINE PROPORTIONAL CONTROL VALVE ASSEMBLY - INLET (DUMP) SECTION**

FIG & ITEM #	PART NUMBER	DESCRIPTION	QTY.	REV.
	7002364	<b>RACINE PROPORTIONAL CONTROL VALVE ASSEMBLY - INLET (DUMP) SECTION</b>	Ref.	
	7002385	Plug Assembly	1	
1	7004848	Plug	1	
2	Kit	O-Ring	1	
3	7002384	Screw, Socket Set	1	
4	7002377	Spring Compression, Helical	1	
5	7002376	Spring Compression, Helical	1	
6	7002371	Poppet	1	
		-----		
	7004850	Seat Assembly	1	
7	7004851	Seat	1	
8	Kit	O-Ring	1	
9	7002324	Plug	4	
10	7002326	Orifice, 0.040	1	
11	7002375	Orifice, 0.062	1	
		-----		
	7002386	Plug, Assembly	1	
12	7004853	Plug	1	
13	Kit	O-Ring	1	
		-----		
	7004854	Solenoid Assembly		
14	7000417	Coil 12VDC	1	
15	7004837	Screw, Slotted, Pan Head	4	
16	7002338	Plate	1	
17	7004824	Sleeve	1	
18	7004835	Sleeve	1	
19	7004836	Case	1	
20	7002334	Spring	1	
21	7004855	Guide, Tube Assembly	1	
	7004838	Tube	1	
	7004839	Plunger	1	
	7004856	Pin and Guide Assembly	1	
	7002340	Guide	1	
	Kit	Packing, Preformed, O-Ring	1	
	7004857	Pin and Quad Ring Assembly	1	
	7004841	Pin	1	
	Kit	Quad Ring	1	
	7004858	Cone and O-Ring Assembly	1	
	7004822	Cone	1	
	Kit	Packing, Preformed, O-Ring	1	
	Kit	Packing, Preformed, O-Ring	1	
22	7002327	Nameplate	1	
23	Kit	O-Ring	1	
24	7002374	Screw, Socket Recessed	2	
25	7002319	Pin	1	
26	7002229	Ball	1	
		-----		

**SECTION 2 TURNTABLE**

# SECTION 2 TURNTABLE

**FIGURE 2-5. RACINE PROPORTIONAL CONTROL VALVE ASSEMBLY - INLET (DUMP) SECTION**

**SECTION 2 TURNTABLE**

FIG & ITEM #	PART NUMBER	DESCRIPTION	QTY.	REV.
	7002330	Seat Assembly	1	
27	7004823	Seat, Ball	1	
28	Kit	O-Ring	1	
		-----		
	7004860	End Cap Assembly	1	
29	7004861	Cap	1	
30	7002223	Plug	1	
31	Kit	O-Ring	1	
32	7002373	Spacer	1	
33	7002379	Spring	1	
		-----		
	7004863	Stem Assembly	1	
34	7004864	Stem	1	
35	Kit	O-Ring	1	
36	Kit	Glyd Ring	1	
37	7002372	Poppet	1	
38	7002370	Seat	1	
39	Kit	O-Ring	1	
40	7002360	Housing, Inlet Manifold	1	
41	Kit	O-Ring	2	
42	Kit	O-Ring	1	
43	Kit	O-Ring	1	
44	Kit	O-Ring	1	
		-----		
	7004833	Seal Kit (Includes Items, 2, 8, 13, 23, 28, 31, 35, 36, 39, 41, 42, 43, 44 and soft items listed under #21) (1 Per Section)	4	

# SECTION 2 TURNTABLE

FIGURE 2-5. RACINE PROPORTIONAL CONTROL VALVE ASSEMBLY - INLET (DUMP) SECTION

FIG & ITEM #	PART NUMBER	DESCRIPTION	QTY.	REV.

**S  
E  
C  
T  
I  
O  
N  
  
2  
  
T  
U  
R  
N  
T  
A  
B  
L  
E**

# SECTION 2 TURNTABLE

FIGURE 2-6. RACINE PROPORTIONAL CONTROL VALVE ASSEMBLY - SERVO ASSEMBLY

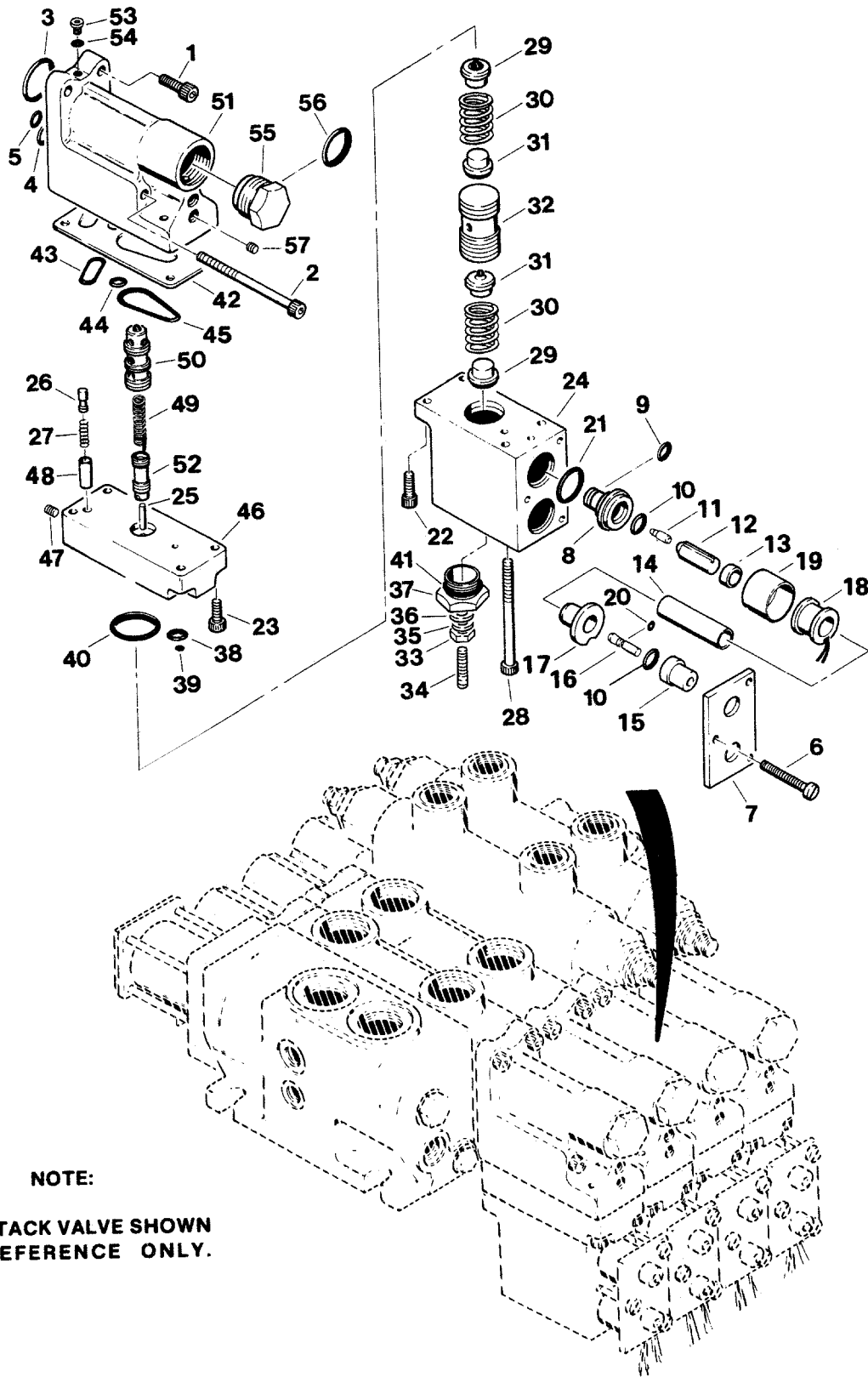

SECTION 2 TURNTABLE

# SECTION 2 TURNTABLE

**FIGURE 2-6. RACINE PROPORTIONAL CONTROL VALVE ASSEMBLY - SERVO ASSEMBLY**

FIG & ITEM #	PART NUMBER	DESCRIPTION	QTY.	REV.
		<b>RACINE PROPORTIONAL CONTROL VALVE ASSEMBLY - SERVO ASSEMBLY</b>	Ref.	
	7004884	Servo Assembly	4	
1	7002231	Screw, Socket Head	2	
2	7004878	Screw, Socket Head	2	
3	Kit	O-Ring	1	
4	Kit	O-Ring	1	
5	Kit	O-Ring	1	
	0100011	Loctite #242	A/R	
		-----		
	7004883	Nose Cone Assembly (Contains Items 8 thru 14)	2	
6	7002240	Screw, Slotted	3	
7	7002218	Plate	1	
		-----		
8	7002210	Nose	1	
9	Kit	O-Ring	1	
10	Kit	O-Ring	2	
11	7000423	Poppet	1	
12	7002212	Plunger	1	
13	7002216	Sleeve	1	
14	7002215	Tube	1	
15	7002214	Retainer	1	
16	7002213	Pin	2	
17	7002211	Cover	1	
18	1420003	Coil, 7.5 Volt	2	
19	7002242	Case	2	
20	Kit	O-Ring	2	
21	Kit	Packing, Preformed, O-Ring	2	
22	7002222	Screw, Socket Head (Short)	2	
23	7002228	Screw, Socket Head (Long)	2	
24	8004818	Body, Control	1	
25	7002238	Pin	1	
26	7002220	Spool	1	
27	7002241	Spring, Compression, Helical	1	
28	7002228	Screw, Socket Head	2	
29	7004880	Spring Seat and Ball	2	
30	7002237	Spring, Contour	2	
31	7004881	Spring Seat and Ball	2	
32	7002206	Control Pilot Piston	1	
33	7002224	Nut, Jam	1	
34	7004813	Screw, Cup Point	1	
35	7004812	Washer	1	
36	Kit	Seal	1	
37	7002209	Plug	1	
38	Kit	Packing, Preformed, O-Ring	1	
39	Kit	Packing, Preformed, O-Ring	1	
40	Kit	Packing, Preformed, O-Ring	1	
41	Kit	Packing, Preformed, O-Ring	1	

**SECTION 2 TURNTABLE**

# SECTION 2 TURNTABLE

**FIGURE 2-6. RACINE PROPORTIONAL CONTROL VALVE ASSEMBLY - SERVO ASSEMBLY**

FIG & ITEM #	PART NUMBER	DESCRIPTION	QTY.	REV.
42	Kit	Seal Plate	1	
43	Kit	Packing, Preformed, O-Ring	1	
44	Kit	Packing, Preformed, O-Ring	1	
45	Kit	Packing, Preformed, O-Ring	1	
46	7004816	Plate, Adapter	1	
47	7004882	Screw, Socket Set	1	
48	7002217	Spool Stop	1	
49	7002234	Spring, Sleeve and Spool	1	
50	7002203	Sleeve Assembly	1	
51	7004817	Body, Servo	1	
52	7002205	Spool	1	
53	7004814	Plug	1	
54	Kit	O-Ring	1	
55	7002704	Plug	1	
56	Kit	O-Ring	1	
	7004808	Ramp	1	
	Kit	Ring	2	
57	7002223	Plug	2	
		-----		
	7004831	Seal Kit (Includes Items 3,4,5,9,10,20,21,36, 38-45,54 and soft items listed under #56)	4	

**SECTION 2 TURNTABLE**

# SECTION 2 TURNTABLE

FIGURE 2-6. RACINE PROPORTIONAL CONTROL VALVE ASSEMBLY - SERVO ASSEMBLY

FIG & ITEM #	PART NUMBER	DESCRIPTION	QTY.	REV.

**S  
E  
C  
T  
I  
O  
N  
  
2  
  
T  
U  
R  
N  
T  
A  
B  
L  
E**

# SECTION 2 TURNTABLE

FIGURE 2-7. CONTROL VALVES INSTALLATION - VICKERS PROPORTIONAL

SECTION 2 TURNTABLE

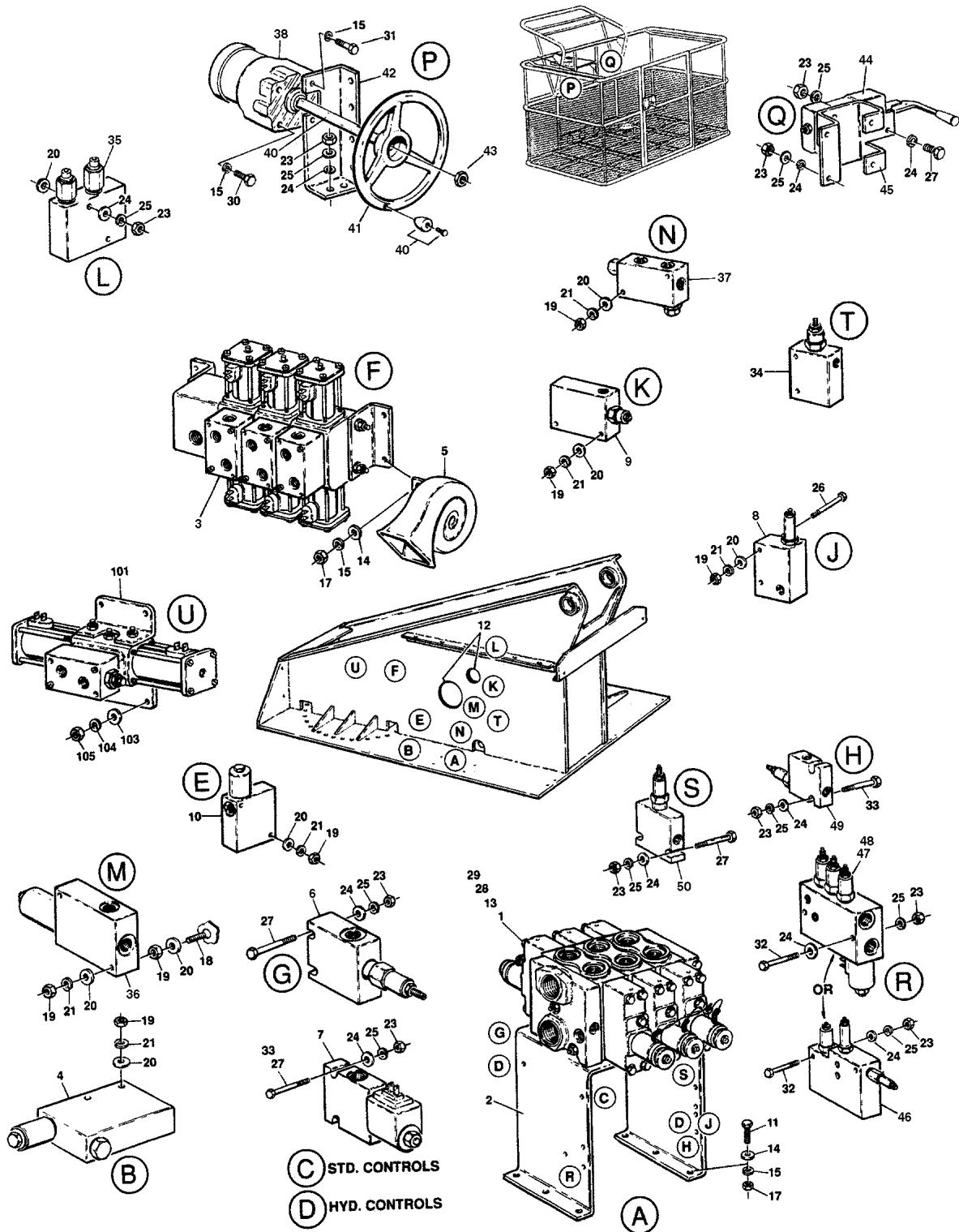



# SECTION 2 TURNTABLE

**FIGURE 2-7. CONTROL VALVES INSTALLATION - VICKERS PROPORTIONAL**

FIG & ITEM #	PART NUMBER	DESCRIPTION	QTY.	REV.
	0237771	CONTROL VALVES INSTALLATION - WITHOUT PROP TELE/WITHOUT ROTATE/WITHOUT 4WS/WITHOUT STEERING WHEEL/STANDARD CONTROLS	Ref.	N
	0237772	CONTROL VALVES INSTALLATION - WITHOUT PROP TELE/WITH ROTATE/WITHOUT 4WS/WITHOUT STEERING WHEEL/STANDARD CONTROLS	Ref.	N
	0252552	CONTROL VALVES INSTALLATION - WITHOUT PROP TELE/WITHOUT ROTATE/WITH 4WS/WITHOUT STEERING WHEEL/STANDARD CONTROLS	Ref.	E
	0252553	CONTROL VALVES INSTALLATION - WITHOUT PROP TELE/WITH ROTATE/WITH 4WS/WITHOUT STEERING WHEEL/STANDARD CONTROLS	Ref.	E
	0238206	CONTROL VALVES INSTALLATION - WITH PROP TELE/WITHOUT ROTATE/WITHOUT 4WS/WITHOUT STEERING WHEEL/STANDARD CONTROLS	Ref.	5
	0238207	CONTROL VALVES INSTALLATION - WITH PROP TELE/WITH ROTATE/WITHOUT 4WS/WITHOUT STEERING WHEEL/STANDARD CONTROLS	Ref.	6
	0252186	CONTROL VALVES INSTALLATION - WITH PROP TELE/WITHOUT ROTATE WITH 4WS/WITHOUT STEERING WHEEL/STANDARD CONTROLS	Ref.	5
	0252187	CONTROL VALVES INSTALLATION - WITH PROP TELE/WITH ROTATE WITH 4WS/WITHOUT STEERING WHEEL/STANDARD CONTROLS	Ref.	5
	0237773	CONTROL VALVES INSTALLATION - WITHOUT PROP TELE/WITHOUT ROTATE/WITHOUT 4WS/WITH STEERING WHEEL/STANDARD CONTROLS (MACHINES BUILT PRIOR TO SEPTEMBER 1991)	Ref.	G
	0252335	CONTROL VALVES INSTALLATION - WITHOUT PROP TELE/WITHOUT ROTATE/WITHOUT 4WS/WITH STEERING WHEEL/STANDARD CONTROLS (MACHINES BUILT SEPTEMBER 1991 TO PRESENT)	Ref.	B
	0237774	CONTROL VALVES INSTALLATION - WITHOUT PROP TELE/WITH ROTATE/WITHOUT 4WS/WITH STEERING WHEEL/STANDARD CONTROLS (MACHINES BUILT PRIOR TO SEPTEMBER 1991)	Ref.	G
	0252336	CONTROL VALVES INSTALLATION - WITHOUT PROP TELE/WITH ROTATE/WITHOUT 4WS/WITH STEERING WHEEL/STANDARD CONTROLS (MACHINES BUILT SEPTEMBER 1991 TO PRESENT)	Ref.	B
	0238208	CONTROL VALVES INSTALLATION - WITH PROP TELE/WITHOUT ROTATE/WITHOUT 4WS/WITH STEERING WHEEL/STANDARD CONTROLS (MACHINES BUILT PRIOR TO SEPTEMBER 1991)	Ref.	A
	0252359	CONTROL VALVES INSTALLATION - WITH PROP TELE/WITH ROTATOR/WITHOUT 4WS/WITH STEERING WHEEL/STANDARD CONTROLS (MACHINES BUILT SEPTEMBER 1991 TO PRESENT)	Ref.	-
	0238209	CONTROL VALVES INSTALLATION - WITH PROP TELE/WITH ROTATE/WITHOUT 4WS/WITH STEERING WHEEL/STANDARD CONTROLS (MACHINES BUILT PRIOR TO SEPTEMBER 1991)	Ref.	A

**SECTION 2 TURNTABLE**

# SECTION 2 TURNTABLE

**FIGURE 2-7. CONTROL VALVES INSTALLATION - VICKERS PROPORTIONAL (CONTINUED)**

FIG & ITEM #	PART NUMBER	DESCRIPTION	QTY.	REV.	
1	0252360	CONTROL VALVES INSTALLATION - WITH PROP TELE/WITH ROTATE/WITHOUT 4WS/WITH STEERING WHEEL/STANDARD CONTROLS (MACHINES BUILT SEPTEMBER 1991 TO PRESENT)	Ref.	-	
	0239221	CONTROL VALVES INSTALLATION - WITH PROP TELE/WITHOUT ROTATE/WITHOUT 4WS/WITHOUT STEERING WHEEL/HYDRAULIC CONTROLS	Ref.	L	
	0239222	CONTROL VALVES INSTALLATION - WITH PROP TELE/WITH ROTATE/WITHOUT 4WS/WITHOUT STEERING WHEEL/HYDRAULIC CONTROLS	Ref.	M	
	0239223	CONTROL VALVES INSTALLATION - WITH PROP TELE/WITHOUT ROTATE WITHOUT 4WS/WITH STEERING WHEEL/HYDRAULIC CONTROLS	Ref.	G	
	0239224	CONTROL VALVES INSTALLATION - WITH PROP TELE/WITH ROTATE/WITHOUT 4WS/WITH STEERING WHEEL/HYDRAULIC CONTROLS	Ref.	F	
		Control Valve Assembly (Vickers) Options: Without Steering Wheel (Standard Controls)		1	
	4640514	3 Section - Prior to October 1994 (Without Prop Tele) (See Figure 2-8 for Breakdown)			
	4640913	3 Section - October 1994 to Present (Without Tele) (See Figure 2-9 for Breakdown)			
	4640524	4 Section - Prior to October 1994) (With Prop Tele) (See Figure 2-8 for Breakdown)			
	4640914	4 Section - October 1994 to Present (See Figure 2-9 for Breakdown)			
2	4640514	With Steering Wheel (Standard Controls) 3 Section (Without Prop Tele) (See Figure 2-8 for Breakdown)	1		
	4640524	4 Section (With Prop Tele) (See Figure 2-8 for Breakdown)			
	4640561	With/Without Steering Wheel (Hydraulic Controls) Prior to October 1994 (See Figure 2-8 for Breakdown)	1		
	4640918	October 1994 to Present (See Figure 2-10 for Breakdown)			
	0901399	Bracket, Mounting	1		
	3		Control Valve Assembly (Bang-Bang) Options: Without Steering Wheel (Standard Controls)	1	
4640711		1 Section (0252186 Installation) (See Figure 2-11 for Breakdown)			
4640462		2 Section (0252552 Installation) (See Figure 2-11 for Breakdown)			
4640447		2 Section (0238206 Installation Prior to May 1993) (See Figure 2-13 for Breakdown)			
4640734		2 Section (0238206 Installation May 1993 to Present) (See Figure 2-11 for Breakdown)			
4640730		2 Section (0252187 Installation) (See Figure 2-11 for Breakdown)			
4640246		3 Section (Prior to June 1995 both 0237771 and 0238207 Installations) (See Figure 2-11 for Breakdown)			

**SECTION 2 TURNTABLE**

# SECTION 2 TURNTABLE

**FIGURE 2-7. CONTROL VALVES INSTALLATION - VICKERS PROPORTIONAL (CONTINUED)**

FIG & ITEM #	PART NUMBER	DESCRIPTION	QTY.	REV.
3 (cont'd)	4640941	3 Section June 1995 to Present both 0237771 and 0238207 Installations) (See Figure 2-12 for Breakdown)		
	4640732	3 Section (0252553 Installation) (See Figure 2-11 for Breakdown)		
	4640247	4 Section (0257772 Installation - Prior to June 1995) (See Figure 2-11 for Breakdown)		
	4640940	4 Section (0257772 Installation - June 1995 to Present) (See Figure 2-12 for Breakdown)		
		With Steering Wheel (Standard Controls)		
	4640461	1 Section (See Figure 2-13 for Breakdown)	1	
	4640447	2 Section (See Figure 2-13 for Breakdown)		
		With/Without Steering Wheel (Hydraulic Controls)		
	4640571	2 Section (See Figure 2-11 for Breakdown)		
	4640246	3 Section - Prior to June 1995 (See Figure 2-11 for Breakdown)		
	4640941	3 Section - June 1995 to Present (See Figure 2-12 for Breakdown)		
4	4640360	Dump Valve Assembly	1	
	7009745	Coil (Vickers/Modular Controls Version)	1	
	7004289	Solenoid Cartridge Less Coil (Vickers/Modular Controls Version)	1	
	7003635	Check Valve Cartridge (Vickers/Modular Controls Version)	1	
	7004368	Coil (Hydraforce Version)	1	
	7012910	Solenoid Cartridge Less Coil (1989 to Present) (Hydraforce Version)	1	
	7010635	Solenoid Cartridge Less Coil (Prior to 1989) (Hydraforce Version)	1	
	7009798	Check Valve Cartridge (Hydraforce Version)	1	
5	0140001	Horn	1	
6		Pressure Reducing Valve Assembly Options: With/Without Steering Wheel (Standard Controls)	1	
	4640522	Pressure Reducing Valve Assembly		
	4640523	Cartridge	1	
	2900698	Seal Kit	1	
	Not Required	With/Without Steering Wheel (Hydraulic Controls)		
7	4640513	Dump Valve Assembly	A/R	
	7003640	Coil (Vickers/Modular Controls Version)	A/R	
	7004289	Cartridge Less Coil (Vickers/Modular Controls Version)	A/R	
	2900503	Seal Kit (Vickers/Modular Controls Version)	A/R	
	7000645	Coil (Hydraforce Version)	A/R	
	7012910	Cartridge Less Coil (Hydraforce Version)	A/R	
	2900756	Seal Kit (Hydraforce Version)	A/R	
	7022390	Nut (Attach Coil to Cartridge)	A/R	
8		Sequence Valve Assembly Options: With/Without Steering Wheel (Standard Controls)	1	
	4640512 Not Required	With/Without Steering Wheel (Hydraulic Controls)		

**SECTION 2 TURNTABLE**

# SECTION 2 TURNTABLE

**FIGURE 2-7. CONTROL VALVES INSTALLATION - VICKERS PROPORTIONAL (CONTINUED)**

FIG & ITEM #	PART NUMBER	DESCRIPTION	QTY.	REV.
9		Control Valve Assembly Options:	1	
		Without Steering Wheel (Standard Controls)		
		4640521 Valve (Without Prop Tele)		
		4640521 Valve (With Prop Tele Built Prior to July 1991)		
		4640771 Cartridge	1	
		2900770 Seal Kit	1	
		Not Required Valve (With Prop Tele Build July 1991 to Present)		
		With Steering Wheel (Standard Controls)		
		4640521 Valve (Without Prop Tele)		
		4640521 Valve (With Prop Tele Built Prior to July 1991)		
		4640771 Cartridge	1	
		2900770 Seal Kit	1	
		Not Required Valve (With Prop Tele Built July 1991 to Present)		
		With/Without Steering Wheel (Hydraulic Controls)		
		4640521 Valve (Built Prior to July 1991)		
		4640771 Cartridge	1	
		2900770 Seal Kit	1	
	Not Required Valve (Built July 1991 to Present)			
10	4640123	Solenoid Valve Assembly	1	
	7004368	Coil (Hydraforce Version)	1	
	7012518	Seal Kit (Hydraforce Version)	1	
	7000558	Coil (FPS Version)	1	
	7006075	Seal Kit (FPS Version)	1	
11	0641614	Bolt 3/8"-16NC x 1 3/4"	A/R	
12	4060808	Shield	A/R	
13	0641708	Bolt 7/16"-14NC x 1"	A/R	
14	4751600	Flatwasher 3/8"	A/R	
15	4761600	Lockwasher 3/8"	A/R	
16	4300034	Stud (Welded on Part - Not Shown)	A/R	
17	3311601	Nut 3/8"-16NC	A/R	
18	4300033	Stud (Welded on Part)	A/R	
19	3311501	Nut 5/16"-18NC	A/R	
20	4751500	Flatwasher 5/16"	A/R	
21	4761500	Lockwasher 5/16"	A/R	
22	Not Used			
23	3311401	Nut 1/4"-20NC	A/R	
24	4751400	Flatwasher 1/4"	A/R	
25	4761400	Lockwasher 1/4"	A/R	
26	0641528	Bolt 5/16"-18NC x 3 1/2"	A/R	
27	0641416	Bolt 1/4"-20NC x 2"	A/R	
28	4751700	Flatwasher 7/16"	A/R	
29	4761700	Lockwasher 7/16"	A/R	
30	0641606	Bolt 3/8"-16NC x 3/4"	A/R	
31	0641608	Bolt 3/8"-16NC x 1"	A/R	
32	0641424	Bolt 1/4"-20NC x 3"	A/R	
33	0641430	Bolt 1/4"-20NC x 3/4"	A/R	
34	4640520	Valve, Relief - Not Mounted is called out on Pump Circuit	1	

**SECTION 2 TURNTABLE**

# SECTION 2 TURNTABLE

**FIGURE 2-7. CONTROL VALVES INSTALLATION - VICKERS PROPORTIONAL (CONTINUED)**

FIG & ITEM #	PART NUMBER	DESCRIPTION	QTY.	REV.
35		Relief Valve Assembly (Machines Built May 1993 to Present) Options:	1	
		Without Steering Wheel (Standard Controls)		
	4640839	Relief Valve Assembly	1	
	7012945	Cartridge, Relief	1	
	7010542	Cartridge, Shuttle	1	
	Not Required	With Steering Wheel (Standard Controls)		
		With/Without Steering Wheel (Hydraulic Controls)		
	4640839	Relief Valve Assembly	1	
	7012945	Cartridge, Relief	1	
	7010542	Cartridge, Shuttle	1	
		<b>Note: Items 36-45 Machines With Steering Wheel Only.</b>		
36	4640360	Dump Valve Assembly	1	
	7009745	Coil (Vickers/Modular Controls Version)	1	
	7004289	Cartridge Less Coil (Vickers/Modular Controls Version)	1	
	7003635	Cartridge, Check (Vickers/Modular Controls Version)	1	
	7004368	Coil (Hydraforce Version)	1	
	7012910	Cartridge Less Coil (Built 1989 to Present) (Hydraforce Version)	1	
	7010635	Cartridge Less Coil (Built through 1988) (Hydraforce Version)	1	
	7009798	Cartridge, Check (Hydraforce Version)	1	
	37	4640151	Flow Divider Assembly	1
38	4640408	Steering Valve Assembly (See Figure 2-15 for Breakdown)	1	
39	1460005	Column, Steering	1	
40	2560066	Handle, Steering Wheel	1	
	3900060	Bolt, Shoulder	1	
	0100011	Loctite #242	A/R	
41	4860097	Wheel, Steering	1	
42		Bracket Options:	1	
	0901255	Bracket (Prior to September 1991)		
	0901804	Bracket (September 1991 to Present)		
43	3300073	Nut, Steering Wheel	1	
44		Rotator Valve Options:		
	Not Required	Machines Without Rotate	0	
	4640434	Machines With Rotate	1	
45		Mounting Bracket Options:		
	0901201	Bracket, Mounting (Prior to September 1991)	1	
	3533219	Plate, Mounting (September 1991 to Present) (Not Shown)	1	
		<b>Note: Items 46-49 Machines Hydraulic Controls Only.</b>		
46		Accessory Valve Options:		
	4640535	Accessory Valve Assembly (Machines built through 1989) (See Figure 2-16 for Breakdown)	1	

**SECTION 2 TURNTABLE**

# SECTION 2 TURNTABLE

**FIGURE 2-7. CONTROL VALVES INSTALLATION - VICKERS PROPORTIONAL (CONTINUED)**

FIG & ITEM #	PART NUMBER	DESCRIPTION	QTY.	REV.
47	4640580	<p><b>Note: 4640535 Accessory Valve is no longer available as a complete assembly. See Figure 2-13 for Individual parts.</b></p> <p>Accessory Valve Assembly (Machines built 1990 to September 1991) (See Figure 2-17 for Breakdown)</p> <p><b>Note: 4640580 Accessory Valve is no longer available as a complete assembly. See Figure 2-14 for Individual parts.</b></p>	1	
48	4640716	<p>Accessory Valve Assembly (Machines built September 1991 to Present) (See Figure 2-17 for Breakdown)</p> <p><b>Note: Complete 4640716 Valves are available. See Figure 2-17 for Individual parts.</b></p>	1	
49	4640354	Relief Valve Assembly	1	
50	4640362	Pressure Reducing Valve Assembly	1	
	7004278	Cartridge (Vickers/Modular Controls Version)	1	
	7012922	Cartridge (Hydraforce Version)	1	
	0238140	<b>EXTEND-A-REACH VALVE INSTALLATION (60H+6 ONLY)</b>	Ref.	-
101	4640519	Control Valve Assembly (See Figure 2-14 for Breakdown)	1	
102	4300038	Stud (Welded on Part)	4	
103	4751500	Flatwasher 5/16"	4	
104	4761500	Lockwasher 5/16"	4	
105	3311501	Nut 5/16"-18NC	4	

**SECTION 2 TURNTABLE**

# SECTION 2 TURNTABLE

FIGURE 2-7. CONTROL VALVES INSTALLATION - VICKERS PROPORTIONAL (CONTINUED)

FIG & ITEM #	PART NUMBER	DESCRIPTION	QTY.	REV.

**S  
E  
C  
T  
I  
O  
N  
  
2  
  
T  
U  
R  
N  
T  
A  
B  
L  
E**

# SECTION 2 TURNTABLE

FIGURE 2-8. VICKERS PROPORTIONAL CONTROL VALVE ASSEMBLY (PRIOR TO OCTOBER 1994)

SECTION 2 TURNTABLE

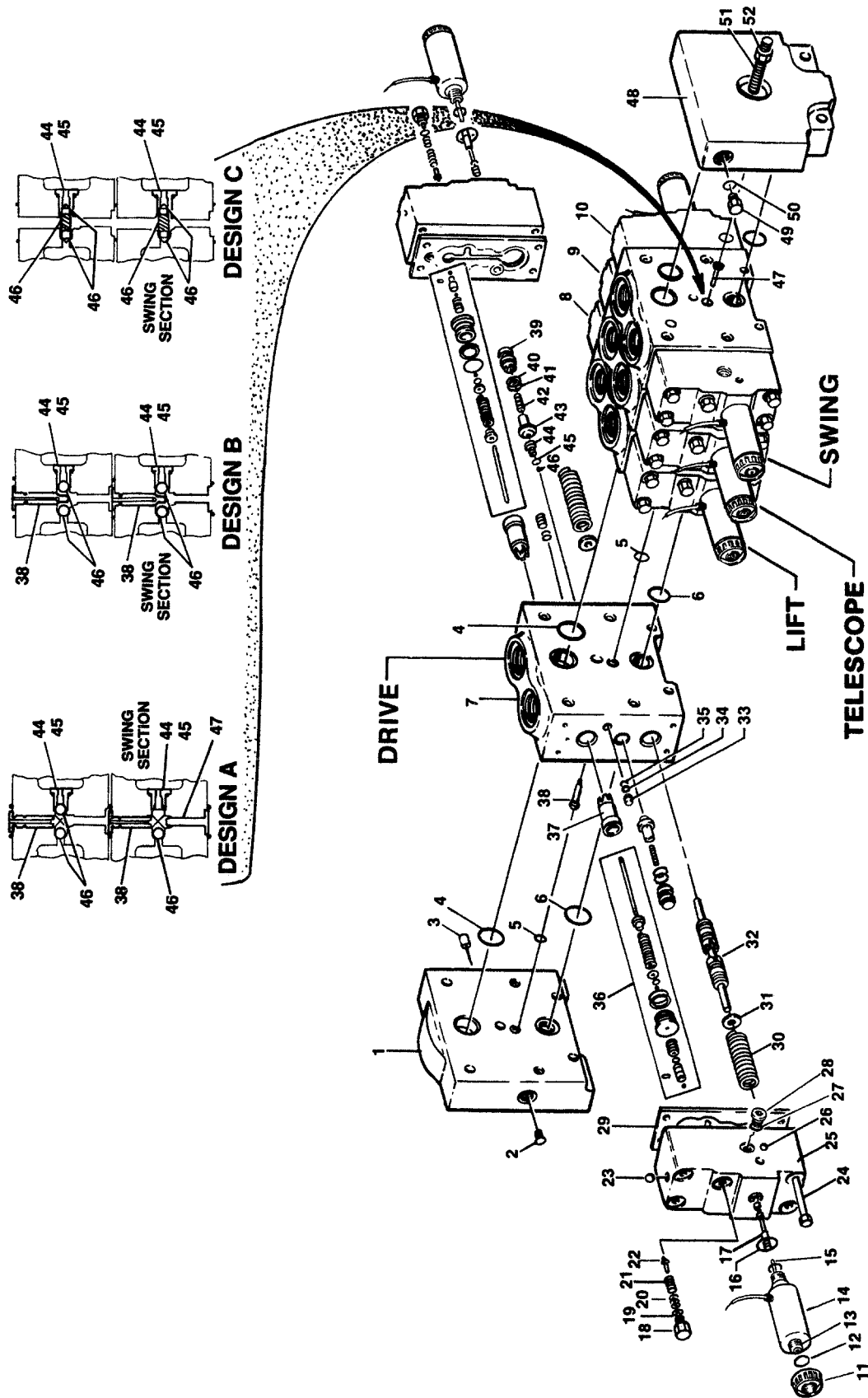



# SECTION 2 TURNTABLE

**FIGURE 2-8. VICKERS PROPORTIONAL CONTROL VALVE ASSEMBLY (PRIOR TO OCTOBER 1994)**

FIG & ITEM #	PART NUMBER	DESCRIPTION	QTY.	REV.
	4640524	<b>VICKERS PROPORTIONAL CONTROL VALVE ASSEMBLY (4 SECTION) (STANDARD) (PRIOR TO OCTOBER 1994)</b>	Ref.	-
	4640561	<b>VICKERS PROPORTIONAL CONTROL VALVE ASSEMBLY (4 SECTION) (HYDRAULIC CONTROLS) (PRIOR TO OCTOBER 1994)</b>	Ref.	-
	4640514	<b>VICKERS PROPORTIONAL CONTROL VALVE ASSEMBLY (3 SECTION) (PRIOR TO OCTOBER 1994)</b>	Ref.	-
1	7006747	Inlet Body (Standard)	1	
	Consult Factory	Inlet Body (Hydraulic Controls)	1	
2	7006725	Setscrew (Standard Only)	1	
3	7006733	Plug	1	
4	Kit	O-Ring	5	
5	Kit	O-Ring	5	
6	Kit	O-Ring	5	
7	7009350	Working Section - Complete (Drive) (4 Section) (Standard)	1	
	7009355	Working Section - Complete (Drive) (4 Section) (Hydraulic Controls)	1	
	7006760	Working Section - Complete (Drive) (3 Section)	1	
8	7006762	Working Section - Complete (Lift) (Standard)	1	
	7009356	Working Section - Complete (Lift) (Hydraulic Controls)	1	
9	7009351	Working Section - Complete (Telescope) (4 Section Only) (Standard)	1	
	7009357	Working Section - Complete (Telescope) (4 Section Only) (Hydraulic Controls)	1	
10	7006763	Working Section - Complete (Swing) (Standard)	1	
	7009358	Working Section - Complete (Swing) (Hydraulic Controls)	1	
11	7012325	Nut, Retaining	2	
12	Kit	O-Ring	2	
13	7009316	Core Tube (Includes O-Ring)	2	
14	7009315	Coil and Frame	2	
15	7009319	Pin	2	
16	Kit	O-Ring	2	
17	7006744	Spool	2	
18	7006726	Plug, Torque	2	
19	Kit	O-Ring	2	
20	7006728	Shim Kit	2	
21	7006729	Spring	2	
22	7006730	Poppet	2	
23	7006731	Ball	2	
24	7006745	Screw	8	
25		Cap, End (Not Sold Separately)	2	
26	7006746	Ball	2	
27	Kit	O-Ring	2	
28	7009323	Plug	2	
29	Kit	Gasket	2	
30	7009324	Spring	2	

**SECTION 2 TURNTABLE**

# SECTION 2 TURNTABLE

**FIGURE 2-8. VICKERS PROPORTIONAL CONTROL VALVE ASSEMBLY (PRIOR TO OCTOBER 1994)  
(CONTINUED)**

FIG & ITEM #	PART NUMBER	DESCRIPTION	QTY.	REV.
31	7009325	Retainer	2	
32		Spool (Not Sold Separately)	1	
33	7006757	Seat	2	
34	Kit	Ring, Back-Up	2	
35	Kit	O-Ring	2	
36	7006732	Servo Stem Assembly	2	
37	7006737	Poppet	2	
38	7009321	Retainer (13/16"-2.1cm Length) (Design A)	1	
	7009363	Retainer (1 3/16"-3cm Length) (Design B)	1	
	Not Required	Retainer (Design C)		
	Kit	O-Ring	1	
39	7006752	Retainer	2	
40	Kit	Ring, Back-Up	2	
41	Kit	O-Ring	2	
42	7006773	Spring	2	
43	7006756	Poppet	2	
44	7006771	Plug, Torque	1	
45	Kit	O-Ring	1	
46	7006761	Ball (Design A - All Sections Except Swing)	2	
	7006761	Ball (Design A - Swing Section)	1	
	7006761	Ball (Design B - All Sections)	2	
	7009369	Poppet (Design C - All Sections)	2	
	7009368	Spring (Design C - All Sections)	1	
47	7006777	Pin, Solid (Design A - Swing Section Only)	1	
	Not Required	Pin, Solid (Design B and Design C)		
48	7006780	Cover End	1	
49	7006778	Plug, Torque	1	
50	Kit	O-Ring	1	
51	7009329	Rod, Tie	3	
52	7006782	Nut	6	
		-----		
	7009330	Seal Kit (Includes Items 4,5,6,12,16,27,34,35, 38,40,41,45, 50 and Servo Stem O-Rings)	4	
	7009395	Seal Kit - Valve Face (Includes Items 4,5 and 6)	5	

**SECTION 2 TURNTABLE**

# SECTION 2 TURNTABLE

FIGURE 2-8. VICKERS PROPORTIONAL CONTROL VALVE ASSEMBLY (PRIOR TO OCTOBER 1994)  
(CONTINUED)

FIG & ITEM #	PART NUMBER	DESCRIPTION	QTY.	REV.

**S  
E  
C  
T  
I  
O  
N  
  
2  
  
T  
U  
R  
N  
T  
A  
B  
L  
E**

# SECTION 2 TURNTABLE

FIGURE 2-9. VICKER PROPORTIONAL CONTROL VALVE ASSEMBLY (STANDARD CONTROLS) (OCTOBER 1994 TO PRESENT)

SECTION 2 TURNTABLE

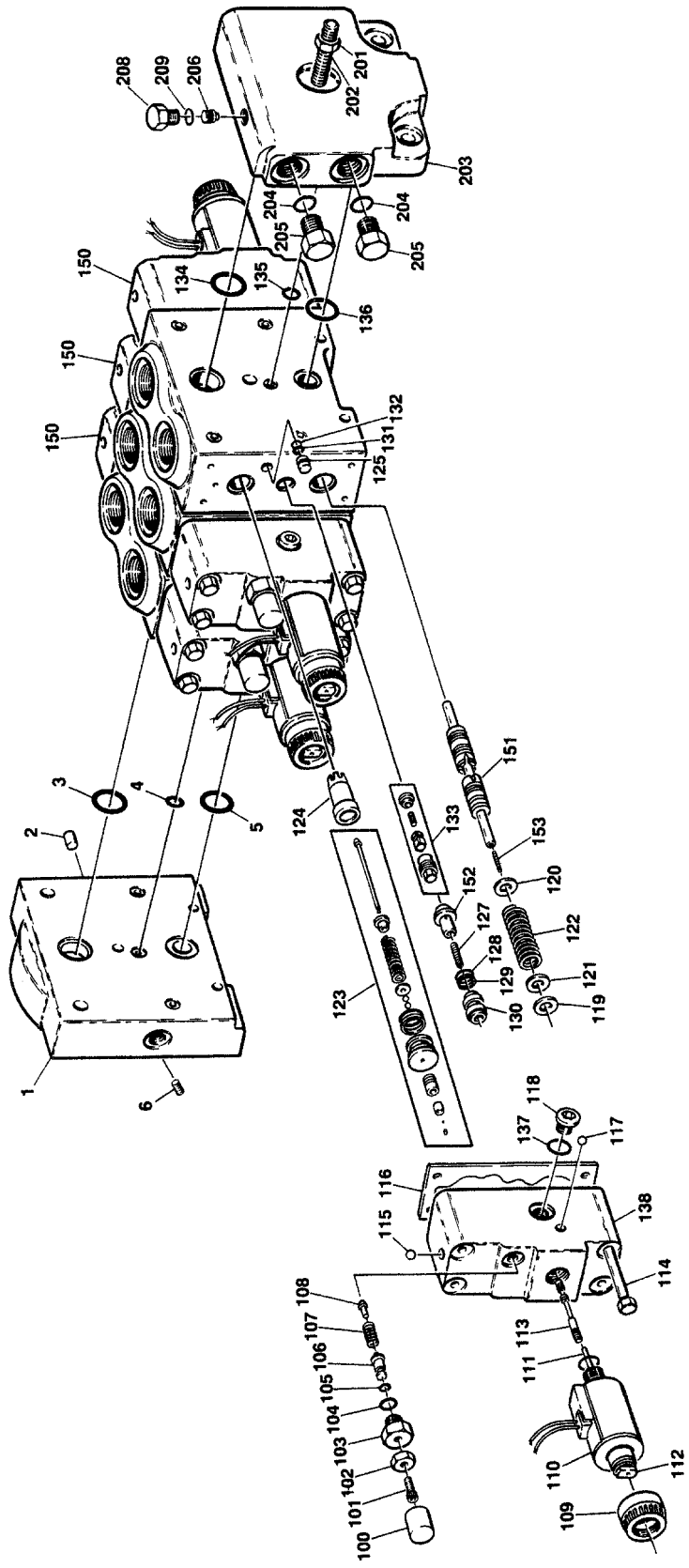

# SECTION 2 TURNTABLE

**FIGURE 2-9. VICKER PROPORTIONAL CONTROL VALVE ASSEMBLY (STANDARD CONTROLS)  
(OCTOBER 1994 TO PRESENT)**

FIG & ITEM #	PART NUMBER	DESCRIPTION	QTY.	REV.
		<b>VICKERS PROPORTIONAL CONTROL VALVE ASSEMBLY (STANDARD CONTROLS) (OCTOBER 1994 TO PRESENT)</b>	Ref.	
	4640913	<b>VICKERS VALVE ASSEMBLY - 3 SECTION</b>	Ref.	-
	4640914	<b>VICKERS VALVE ASSEMBLY - 4 SECTION</b>	Ref.	-
		Inlet Section	Ref.	
1	7006724	Inlet Body	1	
2	7006733	Plug	1	
3	Kit	O-Ring	1	
4	Kit	O-Ring	1	
5	Kit	O-Ring	1	
6	7006725	Setscrew	1	
		Working Sections (Standard Parts)	Ref.	
100	Kit	Cap (2 Per Section)	A/R	
101	7012319	Screw (2 Per Section)	A/R	
102	Kit	Nut (2 Per Section)	A/R	
103	Kit	Plug (2 Per Section)	A/R	
104	Kit	Packing (2 Per Section)	A/R	
105	7012322	Packing (2 Per Section)	A/R	
106	Kit	Piston (2 Per Section)	A/R	
107	Kit	Spring (2 Per Section)	A/R	
108	7006730	Poppet (2 Per Section)	A/R	
109	7012325	Nut, Retaining (2 Per Section)	A/R	
110	7012339	Coil (2 Per Section)	A/R	
111	7009319	Pin (2 Per Section)	A/R	
112	7012326	Core Tube Sub Assembly (2 Per Section)	A/R	
113	7012327	Spool	A/R	
114	7006745	Screw (8 Per Section)	A/R	
115	7006731	Ball	A/R	
116	7006748	Gasket	A/R	
117	7006746	Ball	A/R	
118	7009323	Plug (2 Per Section)	A/R	
119	7012330	Shim (A/R Per Section)	A/R	
120	7012329	Retainer (2 Per Section)	A/R	
121	7012328	Shim (A/R Per Section)	A/R	
122	7009324	Spring (2 Per Section)	A/R	
123	7009320	Stem Servo Sub Assembly (2 Per Section)	A/R	
124	7006737	Poppet (2 Per Section)	A/R	
125	7006757	Seat (2 Per Section)	A/R	
126	Not Used			
127	7006773	Spring (2 Per Section)	A/R	
128	Kit	O-Ring (2 Per Section)	A/R	
129	Kit	Back-up (2 Per Section)	A/R	
130	7009398	Retainer (2 Per Section)	A/R	
131	Kit	Back-up Ring (2 Per Section)	A/R	
132	Kit	O-Ring (2 Per Section)	A/R	

**SECTION 2 TURNTABLE**

# SECTION 2 TURNTABLE

**FIGURE 2-9. VICKER PROPORTIONAL CONTROL VALVE ASSEMBLY (STANDARD CONTROLS)  
(OCTOBER 1994 TO PRESENT) (CONTINUED)**

FIG & ITEM #	PART NUMBER	DESCRIPTION	QTY.	REV.
133	7012333	Load Sense (2 Per Section)	A/R	
134	Kit	O-Ring (2 Per Section)	A/R	
135	Kit	O-Ring (2 Per Section)	A/R	
136	Kit	O-Ring (5 Per Section)	A/R	
137	Kit	O-Ring (2 Per Section)	A/R	
138	Not Serviced	Cap, End (2 Per Section)	A/R	
		-----		
	7009330	Seal Kit (1 Per Section)	A/R	
	7012383	Piston/Spring Kit (Includes Items 1 each of Items 100, 102, 103, 106 and 107) (2 Per Section)	A/R	
150		<b>#1 WORKING SECTION OPTIONS:</b>	1	
	7012332	<b>Drive (All Models)</b>		
151	7012331	Spool	1	
152	7009399	Poppet	2	
153	Not Required	Piston	0	
150		<b>#2 WORKING SECTION OPTIONS:</b>	1	
	7012334	<b>Lift (All Models)</b>		
151	7012331	Spool (1 Per Section)	1	
152	7009397	Poppet (2 Per Section)	2	
153	Not Required	Piston	0	
150		<b>#3 WORKING SECTION OPTIONS:</b>	1	
	7012335	<b>Swing ("H" and "HX" Models Without Prop. Tele.)</b>		
151	7012340	Spool	1	
152	7009399	Poppet	2	
153	7012300	Piston	2	
	7012334	<b>Telescope ("H" and "HX" Models With Prop. Tele.)</b>		
	70123334	<b>Lift ("HA" Models)</b>		
151	7012331	Spool	1	
152	7009397	Poppet	2	
153	Not Required	Piston	0	
150		<b>#4 WORKING SECTION OPTIONS:</b>	1	
	Not Required	<b>("H" and "HX" Models Without Prop. Tele.)</b>		
	7012335	<b>Swing ("H" and "HX" Models With Prop. Tele.)</b>		
	7012335	<b>Swing ("HA" Models)</b>		
151	7012340	Spool	1	
152	7009399	Poppet	2	
153	7012300	Piston	2	
		<b>OUTLET SECTION</b>	Ref.	
201	7006782	Nut	6	
202	7009361	Rod, Tie	3	
203	7012337	Cover End	1	

**SECTION 2 TURNTABLE**

# SECTION 2 TURNTABLE

FIGURE 2-9. VICKER PROPORTIONAL CONTROL VALVE ASSEMBLY (STANDARD CONTROLS)  
(OCTOBER 1994 TO PRESENT) (CONTINUED)

FIG & ITEM #	PART NUMBER	DESCRIPTION	QTY.	REV.
204	Kit	O-Ring	2	
205	7006778	Plug	2	
206	7012338	Setscrew Orifice Sub-Assembly	1	
207	Kit	O-Ring	1	
208	7012336	Plug	1	

**S  
E  
C  
T  
I  
O  
N  
  
2  
  
T  
U  
R  
N  
T  
A  
B  
L  
E**

# SECTION 2 TURNTABLE

FIGURE 2-10. VICKERS PROPORTIONAL CONTROL VALVE ASSEMBLY (HYDRAULIC CONTROLS) (OCTOBER 1994 TO PRESENT)

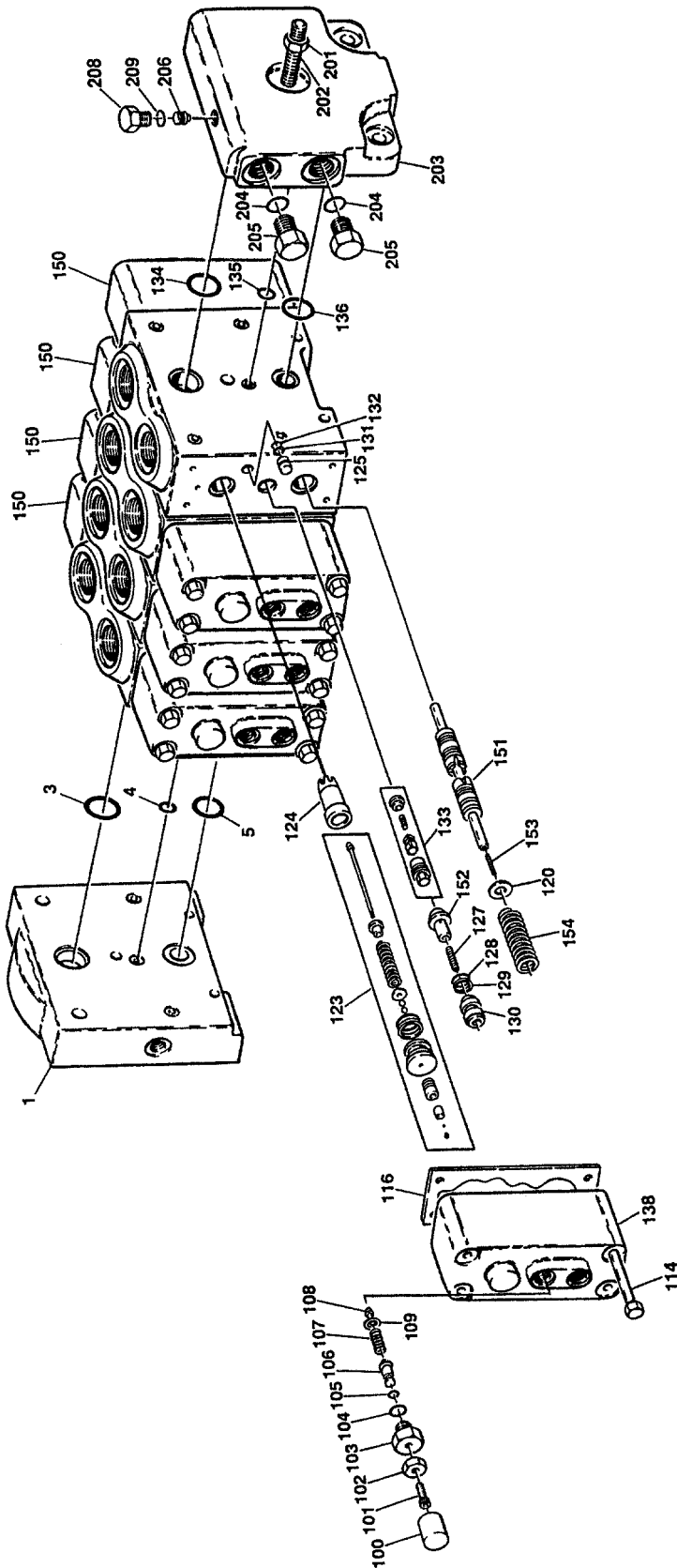

SECTION 2 TURNTABLE



# SECTION 2 TURNTABLE

**FIGURE 2-10. VICKERS PROPORTIONAL CONTROL VALVE ASSEMBLY (HYDRAULIC CONTROLS)  
(OCTOBER 1994 TO PRESENT)**

FIG & ITEM #	PART NUMBER	DESCRIPTION	QTY.	REV.
		<b>VICKERS PROPORTIONAL CONTROL VALVE ASSEMBLY (HYDRAULIC CONTROLS) (OCTOBER 1994 TO PRESENT)</b>	Ref.	
	4640918	<b>VICKERS VALVE ASSEMBLY - 4 SECTION</b>	Ref.	
		<b>INLET SECTION</b>	Ref.	
1	7012348	Inlet Body	1	
2	Not Used			
3	Kit	O-Ring	1	
4	Kit	O-Ring	1	
5	Kit	O-Ring	1	
		<b>WORKING SECTIONS (STANDARD PARTS)</b>	Ref.	
100	7012343	Cap (2 Per Section)	A/R	
101	7012342	Screw (2 Per Section)	A/R	
102	7012341	Nut (2 Per Section)	A/R	
103	7012344	Plug (2 Per Section)	A/R	
104	Kit	Packing (2 Per Section)	A/R	
105	7012322	Packing (2 Per Section)	A/R	
106	7012323	Piston (2 Per Section)	A/R	
107	7012346	Spring (2 Per Section)	A/R	
108	7006730	Poppet (2 Per Section)	A/R	
109	7006728	Shim Kit (2 Per Section)	A/R	
110	Not Used			
111	Not Used			
112	Not Used			
113	Not Used			
114	7012347	Screw (8 Per Section)	A/R	
115	Not Used			
116	Kit	Gasket	A/R	
117	Not Used			
118	Not Used			
119	Not Used			
120	7012349	Retainer (2 Per Section)	A/R	
121	Not Used			
122	Not Used			
123	7006732	Stem Servo Sub Assembly (2 Per Section)	A/R	
124	7006737	Poppet (2 Per Section)	A/R	
125	7012350	Plug (2 Per Section)	A/R	
126	Not Used			
127	7006773	Spring (2 Per Section)	A/R	
128	Kit	O-Ring (2 Per Section)	A/R	
129	Kit	Back-up (2 Per Section)	A/R	
130	7012353	Retainer (2 Per Section)	A/R	
131	Kit	Back-up Ring (2 Per Section)	A/R	
132	Kit	O-Ring (2 Per Section)	A/R	
133	7012352	Load Sense (2 Per Section)	A/R	
134	Kit	O-Ring (2 Per Section)	A/R	

**SECTION 2 TURNTABLE**

# SECTION 2 TURNTABLE

**FIGURE 2-10. VICKERS PROPORTIONAL CONTROL VALVE ASSEMBLY (HYDRAULIC CONTROLS)  
(OCTOBER 1994 TO PRESENT) (CONTINUED)**

**SECTION 2 TURNTABLE**

FIG & ITEM #	PART NUMBER	DESCRIPTION	QTY.	REV.
135	Kit	O-Ring (2 Per Section)	A/R	
136	Kit	O-Ring (5 Per Section)	A/R	
137	Not Used			
138	Not Serviced	Cap, End (2 Per Section)	A/R	
	7009330	----- Seal Kit (1 Per Section)	A/R	
150		<b>#1 WORKING SECTION OPTIONS:</b>	Ref.	
	7012356	<b>Drive</b>		
151	7012355	Spool	1	
152	7009399	Poppet	2	
153	7012300	Piston	2	
154	7012354	Spring	2	
150		<b>#2 WORKING SECTION OPTIONS:</b>	Ref.	
	7012334	<b>Lift</b>		
151	7012331	Spool	1	
152	7009397	Poppet	2	
153	Not Required	Piston	0	
154	7006749	Spring	2	
150		<b>#3 WORKING SECTION OPTIONS:</b>	Ref.	
	7012334	<b>Telescope</b>		
151	7012331	Spool	1	
152	7009397	Poppet	2	
153	Not Required	Piston	0	
154	7006749	Spring	2	
150		<b>#4 WORKING SECTION OPTIONS:</b>	Ref.	
	7012335	<b>Swing</b>		
151	4640913	Spool	1	
152	7009399	Poppet	2	
153	7012300	Piston	2	
154	7006749	Spring	2	
		<b>OUTLET SECTION</b>	Ref.	
201	7006782	Nut	6	
202	7009329	Rod, Tie	3	
203	7012337	Cover, End	1	
204	Kit	O-Ring	2	
205	7006778	Plug	2	
206	7012338	Setscrew Orifice Sub-Assembly	1	
207	Kit	O-Ring	1	
208	7012336	Plug	1	

# SECTION 2 TURNTABLE

FIGURE 2-10. VICKERS PROPORTIONAL CONTROL VALVE ASSEMBLY (HYDRAULIC CONTROLS)  
(OCTOBER 1994 TO PRESENT) (CONTINUED)

FIG & ITEM #	PART NUMBER	DESCRIPTION	QTY.	REV.

**S  
E  
C  
T  
I  
O  
N  
  
2  
  
T  
U  
R  
N  
T  
A  
B  
L  
E**

# SECTION 2 TURNTABLE

FIGURE 2-11. CONTROL VALVE ASSEMBLY - BANG-BANG WITH DUMP SECTION

SECTION 2 TURNTABLE

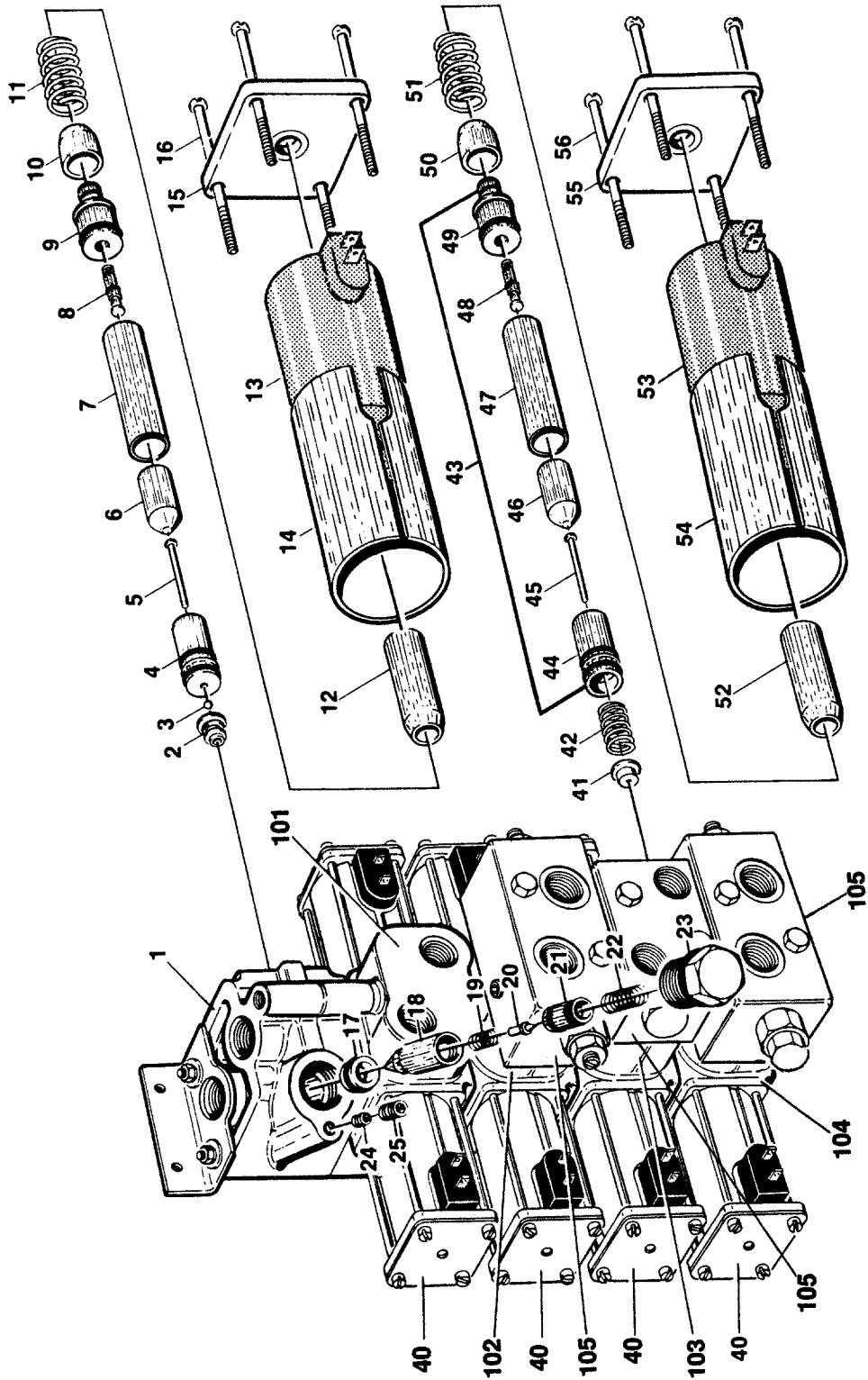

# SECTION 2 TURNTABLE

**FIGURE 2-11. CONTROL VALVE ASSEMBLY - BANG-BANG WITH DUMP SECTION**

FIG & ITEM #	PART NUMBER	DESCRIPTION	QTY.	REV.
		<b>CONTROL VALVE ASSEMBLY - BANG-BANG WITH DUMP SECTION</b>	Ref.	
	4640711	Valve Assembly - 1 Section	Ref.	-
	4640462	Valve Assembly - 2 Section		
	4640734	Valve Assembly - 2 Section	Ref.	-
	4640730	Valve Assembly - 2 Section	Ref.	-
	4640571	Valve Assembly - 2 Section	Ref.	B
	4640246	Valve Assembly - 3 Section	Ref.	A
	4640732	Valve Assembly - 3 Section	Ref.	-
	4640247	Valve Assembly - 4 Section	Ref.	A
1	7002304	<b>DUMP SECTION</b>	Ref.	
		Solenoid Assembly		
2	7004823	Seat	1	
	7002378	O-Ring	1	
3	7002229	Ball	1	
		Guide Tube Assembly	1	
4	7004822	Cone, Female	1	
	7004840	O-Ring	1	
5	7002346	Pin, Push	1	
6	7004839	Plunger	1	
7	7004838	Tube, Guide	1	
8	7004841	Pin, Push	1	
	7002342	O-Ring	1	
9	7002340	Guide, External Push Pin	1	
	7002337	O-Ring	1	
10	7004834	Sleeve, Inner Flux	1	
11	7002334	Spring	1	
12	7004835	Sleeve, Outer Flux	1	
13	7000417	Coil	1	
14	7004836	Case, Solenoid	1	
15	7002338	Plate, End	1	
	7002327	Nameplate	1	
16	7004837	Screw	4	
17	7002322	Seat	1	
	7004826	O-Ring	1	
		Main Relief (Poppet) Valve	1	
18	7002321	Case, Poppet	1	
19	7002328	Spring	1	
20	7002294	Poppet	1	
21	7002320	Seat, Adjustable	1	
	7004842	O-Ring	1	
22	7002329	Spring	1	
23	7002323	Plug	1	
	7000102	O-Ring	1	
24	7002326	Orifice	1	
25	7002324	Plug	1	

**SECTION 2 TURNTABLE**

# SECTION 2 TURNTABLE

**FIGURE 2-11. CONTROL VALVE ASSEMBLY - BANG-BANG WITH DUMP SECTION (CONTINUED)**

FIG & ITEM #	PART NUMBER	DESCRIPTION	QTY.	REV.
		<b>WORKING SECTIONS (STANDARD PARTS)</b>	Ref.	
40	7004859	Solenoid Assembly (2 Per Section) (Includes Items 43-56)	A/R	
41	7002274	Washer (4640462, 4640246 and 4640247 Valves) (2 Per Section)	A/R	
42	7002348	Spring (2 Per Section)	A/R	
43	7002305	Guide Tube Assembly (1 Per Solenoid Assembly)	A/R	
44	7002345	Cone, Female (1 Per Solenoid Assembly)	A/R	
	Kit	O-Ring (1 Per Solenoid Assembly)	A/R	
	Kit	O-Ring (1 Per Solenoid Assembly)	A/R	
45	7002346	Pin, Push (1 Per Solenoid Assembly)	A/R	
46	7002344	Plunger (1 Per Solenoid Assembly)	A/R	
47	7000470	Tube, Guide (1 Per Solenoid Assembly)	A/R	
48	7002341	Pin, Actuator (1 Per Solenoid Assembly)	A/R	
	Kit	Ring, Quad (1 Per Solenoid Assembly)	A/R	
49	7002340	Guide, External Push Pin (1 Per Solenoid Assembly)	A/R	
	Kit	O-Ring (1 Per Solenoid Assembly)	A/R	
50	7002333	Sleeve, Inner Flux (1 Per Solenoid Assembly)	A/R	
51	7002334	Spring (1 Per Solenoid Assembly)	A/R	
52	7002336	Sleeve, Outer Flux (1 Per Solenoid Assembly)	A/R	
53	7000418	Coil (1 Per Solenoid Assembly)	A/R	
54	7002335	Case, Solenoid (1 Per Solenoid Assembly)	A/R	
55	7002338	Plate, End (1 Per Solenoid Assembly)	A/R	
56	7002339	Screw (4 Per Solenoid Assembly)	A/R	
		<b>WORKING SECTION (VARIABLE)</b>	Ref.	
		<b>Note: Complete Sections listed below include items 40-56 and relief valve assembly when equipped.</b>		
101		Section #1 Options:	1	
	7002316	Level Section (4640711, 4640462 and 4640734 Valves)		
	7002317	Rotate Section (4640730, 4640732 and 4640247 Valves)		
	7002315	Steer/Tele Section (4640571 and 4640246 Valves)		
102		Section #2 Options:	1	
	Not Required	(4640711 Valves)	1	
	7002315	Steer/Tele Section (4640462, 4640734, 4640246 and 4640732 Valves)		
	7002316	Level Section (4640730, 4640571 and 4640247 Valves)		
103		Section #3 Options:	1	
	Not Required	(4640711, 4640462, 4640734, 4640730 and 4640571 Valves)	1	
	7002315	Steer/Tele Section (4640246 Valves)		
	7002316	Level Section (4640732 and 4640247 Valves)		
104		Section #4 Options:	1	
	Not Required	(All except 464247 Valve)	1	
	7002315	Steer/Tele Section (4640247 Valve Only)		

**SECTION 2 TURNTABLE**

# SECTION 2 TURNTABLE

**FIGURE 2-11. CONTROL VALVE ASSEMBLY - BANG-BANG WITH DUMP SECTION (CONTINUED)**

FIG & ITEM #	PART NUMBER	DESCRIPTION	QTY.	REV.
105		-----		
		Relief Valve Options:	A/R	
	7000468	Crossover Relief Valve Assembly - 7002315 Steer/ Tele Sections) (Due to various suppliers - internal components are no longer field serviceable)		
	7002262	Dual Pilot Check Valve Assembly - 7002316 Level Sections (Due to various suppliers - internal com- ponents are no longer field serviceable)	A/R	
		-----		
	7000414	Seal Kit - Working Section	4	
	7000413	Seal Kit - Dump Section	1	

SECTION 2 TURNTABLE

# SECTION 2 TURNTABLE

FIGURE 2-12. CONTROL VALVE ASSEMBLY - BANG-BANG WITH DUMP SECTION

SECTION 2 TURNTABLE

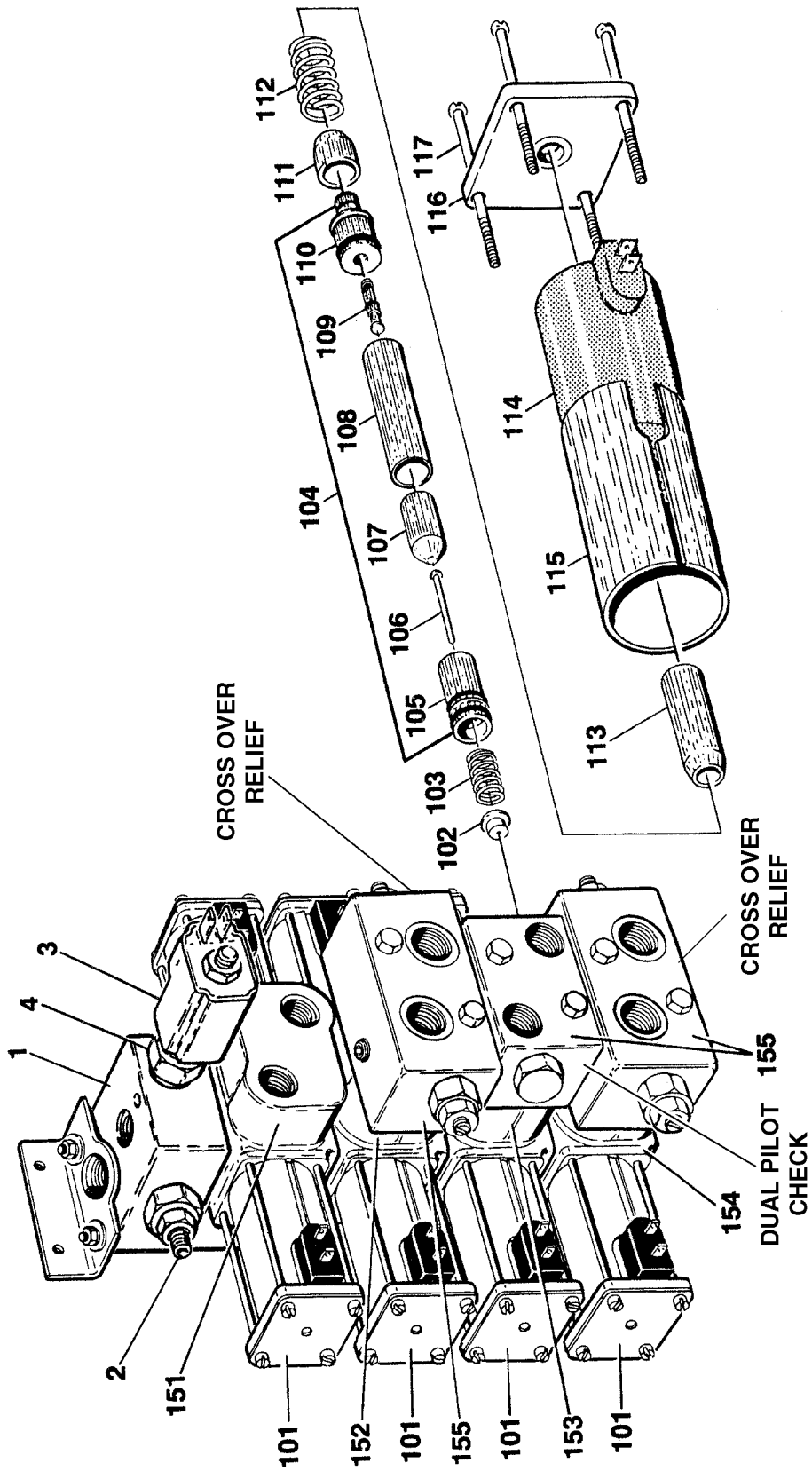



# SECTION 2 TURNTABLE

**FIGURE 2-12. CONTROL VALVE ASSEMBLY - BANG-BANG WITH DUMP SECTION**

FIG & ITEM #	PART NUMBER	DESCRIPTION	QTY.	REV.
		<b>CONTROL VALVE ASSEMBLY - BANG-BANG WITH DUMP SECTION</b>	Ref.	
	4640941	Valve Assembly - 3 Section	Ref.	-
	4640940	Valve Assembly - 4 Section	Ref.	-
		<b>DUMP SECTION ASSEMBLY</b>	Ref.	
1	7002447	Dump Section - Complete	1	
2	7002448	Cartridge	1	
	7002449	Seal Kit - 7002448 Cartridge	1	
3	7002450	Coil	1	
4	7002451	Cartridge without Coil	1	
	7011118	Seal Kit - 7002451 Cartridge	1	
		-----		
	7000448	O-Ring (Between Sections)	2	
		<b>WORKING SECTIONS (STANDARD PARTS)</b>	Ref.	
101	7004859	Solenoid Assembly	2	
102	7003825	Washer	1	
103	7002348	Spring	1	
104	7002305	Guide Tube Assembly	1	
105	7002345	Cone, Female	1	
	Kit	O-Ring	1	
	Kit	O-Ring	1	
106	7002346	Pin, Push	1	
107	7002344	Plunger	1	
108	7000470	Tube, Guide	1	
109	7002341	Pin, Actuator	1	
	Kit	Ring, Quad	1	
110	7002340	Guide, External Push Pin	1	
	Kit	O-Ring	1	
111	7002333	Sleeve, Inner Flux	1	
112	7002334	Spring	1	
113	7002336	Sleeve, Outer	1	
114	7000418	Coil	1	
115	7002335	Case, Solenoid	1	
116	7002338	Plate, End	1	
	7002327	Nameplate	1	
117	7002339	Screw	4	
		-----		
	7000414	Seal Kit - Working Section (1 Per Section)	2	
		<b>WORKING SECTIONS - COMPLETE (Includes Items 101-117 and Relief Valve Assembly when Equipped)</b>	Ref.	
151		<b>#1 Section Options:</b>	1	
	7002315	Steer (4640941 Valve)		
	7002317	Rotate (4640940 Valve)		

SECTION 2 TURNTABLE

# SECTION 2 TURNTABLE

**FIGURE 2-12. CONTROL VALVE ASSEMBLY - BANG-BANG WITH DUMP SECTION (CONTINUED)**

FIG & ITEM #	PART NUMBER	DESCRIPTION	QTY.	REV.
152	Use 7011182 7002315	<b>#2 Section Options:</b> Level (4640941 Valve) (was p/n 7002316) Steer (4640940 Valve)	1	
153	7002315 7002316	<b>#3 Section Options:</b> Telescope (4640941 Valve) Level (4640940 Valve)	1	
154	Not Required 7002315	<b>#4 Section Options:</b> (4640941 Valve) Telescope (4640940 Valve)	A/R	
155	7000468	<b>Relief Valve Options:</b> Crossover Relief Valve Assembly - 7002315 Steer/ Telescope Sections (Due to various supplies internal components are not field serviceable)	A/R	
	Use 7011183	Dual Pilot Check Valve Assembly - Use 7011182 (was p/n 7002316) Level Sections (Due to various suppliers internal components are not field ser- viceable) (was p/n 7002262)	A/R	
	7004607	----- Kit, Stacking Section	1	

**SECTION 2 TURNTABLE**

# SECTION 2 TURNTABLE

FIGURE 2-12. CONTROL VALVE ASSEMBLY - BANG-BANG WITH DUMP SECTION (CONTINUED)

FIG & ITEM #	PART NUMBER	DESCRIPTION	QTY.	REV.

**S  
E  
C  
T  
I  
O  
N  
  
2  
  
T  
U  
R  
N  
T  
A  
B  
L  
E**

# SECTION 2 TURNTABLE

FIGURE 2-13. CONTROL VALVE ASSEMBLY - BANG-BANG WITH INLET RELIEF

SECTION 2 TURNTABLE

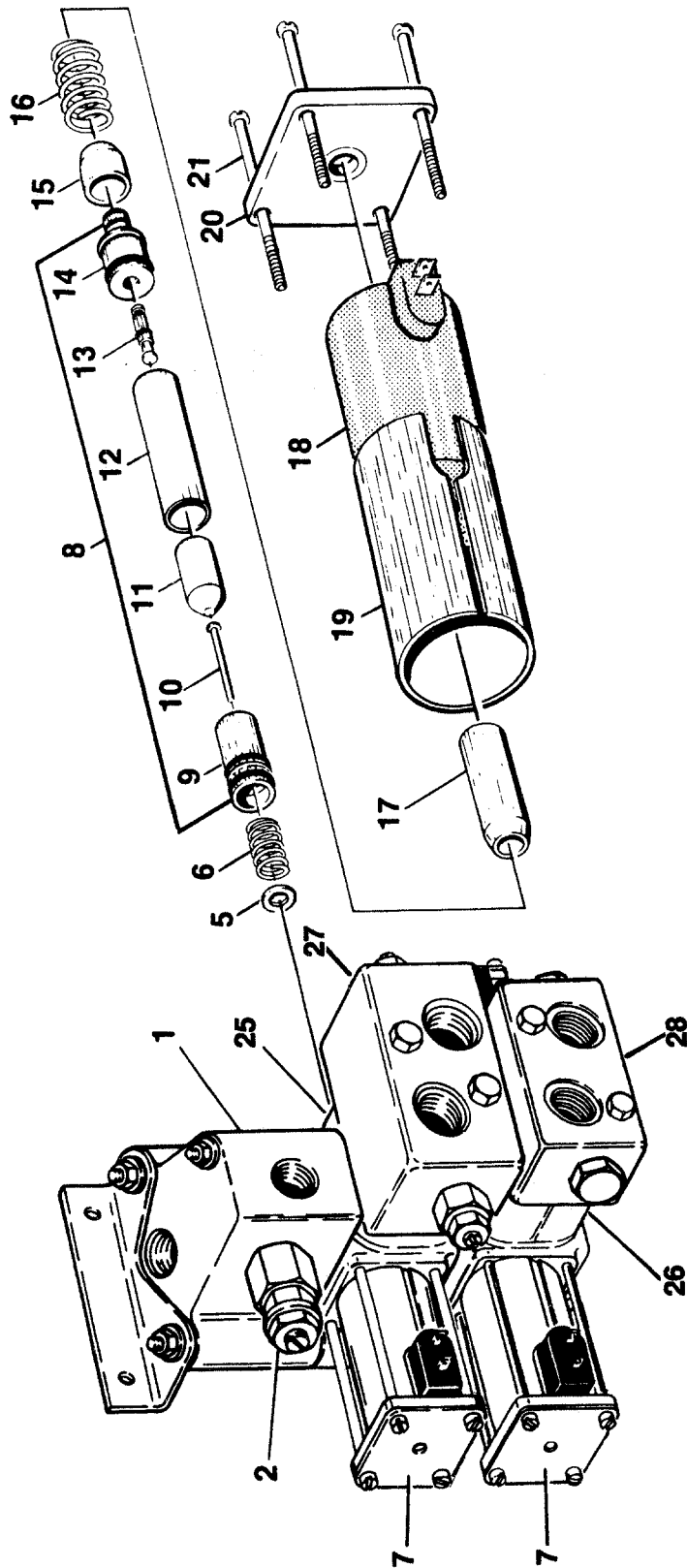

# SECTION 2 TURNTABLE

**FIGURE 2-13. CONTROL VALVE ASSEMBLY - BANG-BANG WITH INLET RELIEF**

FIG & ITEM #	PART NUMBER	DESCRIPTION	QTY.	REV.
		<b>CONTROL VALVE ASSEMBLY - BANG-BANG WITH INLET RELIEF</b>	Ref.	
	4640461	<b>VALVE ASSEMBLY - 1 SECTION</b>	Ref.	A
	4640447	<b>VALVE ASSEMBLY - 2 SECTION</b>	Ref.	A
1	4640820	<b>INLET RELIEF SECTION ASSEMBLY</b>	Ref.	
2	7000447	Cartridge	1	
	7000413	Seal Kit - 7002254 Section	1	
3	Not Used			
4	Not Used			
		<b>WORKING SECTIONS ASSEMBLY (STANDARD PARTS)</b>	Ref.	
5	7002274	Washer (2 Per Section)	A/R	
6	7002273	Spring (2 Per Section)	A/R	
7	7004859	Solenoid Assembly (2 Per Section)	A/R	
8	7002305	Guide Tube Assembly (1 Per Solenoid Assembly)	A/R	
9	7002345	Female Cone/O-Ring Assembly (1 Per Solenoid Assembly)	A/R	
10	7002346	Pin, Push (1 Per Solenoid Assembly)	A/R	
11	7002344	Plunger (1 Per Solenoid Assembly)	A/R	
12	7000470	Tube, Guide (1 Per Solenoid Assembly)	A/R	
13	7002341	Actuator Pin/Quad Ring Assembly (1 Per Solenoid Assembly)	A/R	
14	7002340	Pin Guide/O-Ring Assembly (1 Per Solenoid Assembly)	A/R	
15	7002333	Sleeve, Inner Flux (1 Per Solenoid Assembly)	A/R	
16	7002334	Spring (1 Per Solenoid Assembly)	A/R	
17	7002336	Sleeve, Outer Flux (1 Per Solenoid Assembly)	A/R	
18	7000418	Coil (1 Per Solenoid Assembly)	A/R	
19	7002335	Case, Solenoid (1 Per Solenoid Assembly)	A/R	
20	7002338	Plate, End (1 Per Solenoid Assembly)	A/R	
21	7002339	Screw (4 Per Solenoid Assembly)	A/R	
	7000414	Seal Kit - Working Section (1 Per Section)	A/R	
		<b>WORKING SECTIONS (VARIABLE PARTS)</b>	Ref.	
25	Not Required	Section #1 Options: 4640461 Valve	1	
	7000466	4640447 Valve (Includes Item 27)		
26	7002257	Section #2 Options: 4640461 and 4640447 Valves (Includes Item 28)	1	
		Relief Valve Options:		

# SECTION 2 TURNTABLE

**FIGURE 2-13. CONTROL VALVE ASSEMBLY - BANG-BANG WITH INLET RELIEF (CONTINUED)**

FIG & ITEM #	PART NUMBER	DESCRIPTION	QTY.	REV.
27	7000468	Crossover Relief Valve Assembly - 7000466 Section (Due to various suppliers - internal components are no longer field serviceable)	1	
28	7002262	Dual Pilot Check Valve Assembly 7002257 Section (Due to various suppliers - internal components are no longer field serviceable)	1	

**SECTION 2 TURNTABLE**

# SECTION 2 TURNTABLE

FIGURE 2-13. CONTROL VALVE ASSEMBLY - BANG-BANG WITH INLET RELIEF (CONTINUED)

FIG & ITEM #	PART NUMBER	DESCRIPTION	QTY.	REV.

**S  
E  
C  
T  
I  
O  
N  
  
2  
  
T  
U  
R  
N  
T  
A  
B  
L  
E**

# SECTION 2 TURNTABLE

FIGURE 2-14. CONTROL VALVE ASSEMBLY - 1 SECTION BANG-BANG (4WS ONLY)

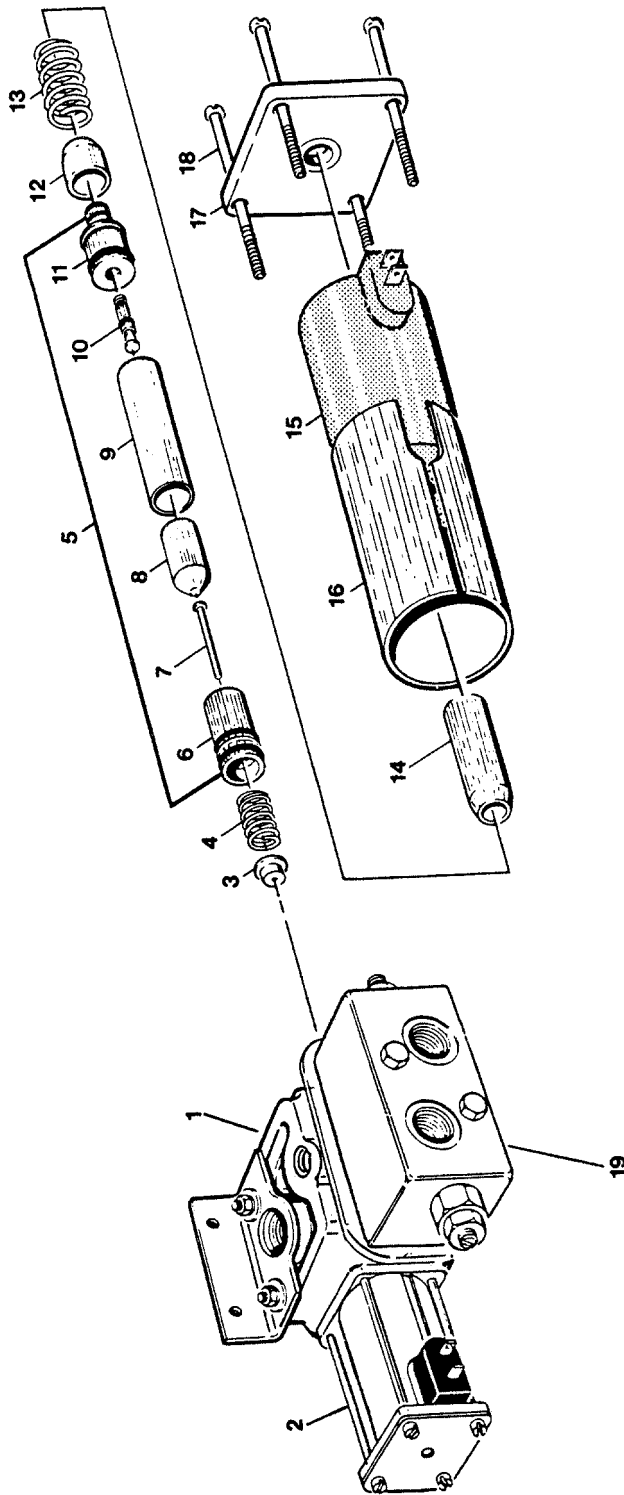

SECTION 2 TURNTABLE



# SECTION 2 TURNTABLE

**FIGURE 2-14. CONTROL VALVE ASSEMBLY - 1 SECTION BANG-BANG (4WS ONLY)**

FIG & ITEM #	PART NUMBER	DESCRIPTION	QTY.	REV.
	4640519	<b>CONTROL VALVE ASSEMBLY - 1 SECTION BANG-BANG (4WS ONLY)</b>	Ref.	-
1	7002315	Telescope Section - Complete	1	
2	7004859	Solenoid Assembly	2	
3	8002274	Washer	1	
4	7002348	Spring	1	
5	7002305	Guide Tube Assembly	1	
6	7002345	Cone, Female	1	
	Kit	O-Ring	1	
	Kit	O-Ring	1	
7	7002346	Pin, Push	1	
8	7002344	Plunger	1	
9	7000470	Tube, Guide	1	
10	7002341	Pin, Actuator	1	
	Kit	Ring, Quad	1	
11	7002340	Guide, External Push Pin	1	
	Kit	O-Ring	1	
12	702333	Sleeve, Inner Flux	1	
13	7002334	Spring	1	
14	7002336	Sleeve, Outer Flux	1	
15	7000418	Coil	1	
16	7002335	Case, Solenoid	1	
17	7002338	Plate, End	1	
	7002327	Nameplate	1	
18	7002339	Screw	4	
19	7000468	Crossover Relief Valve Assembly (Due to various suppliers - internal components are no longer field serviceable)	1	
	7000414	----- Seal Kit - Working Section	1	

**SECTION 2 TURNTABLE**

# SECTION 2 TURNTABLE

FIGURE 2-15. STEERING VALVE ASSEMBLY

SECTION 2 TURNTABLE

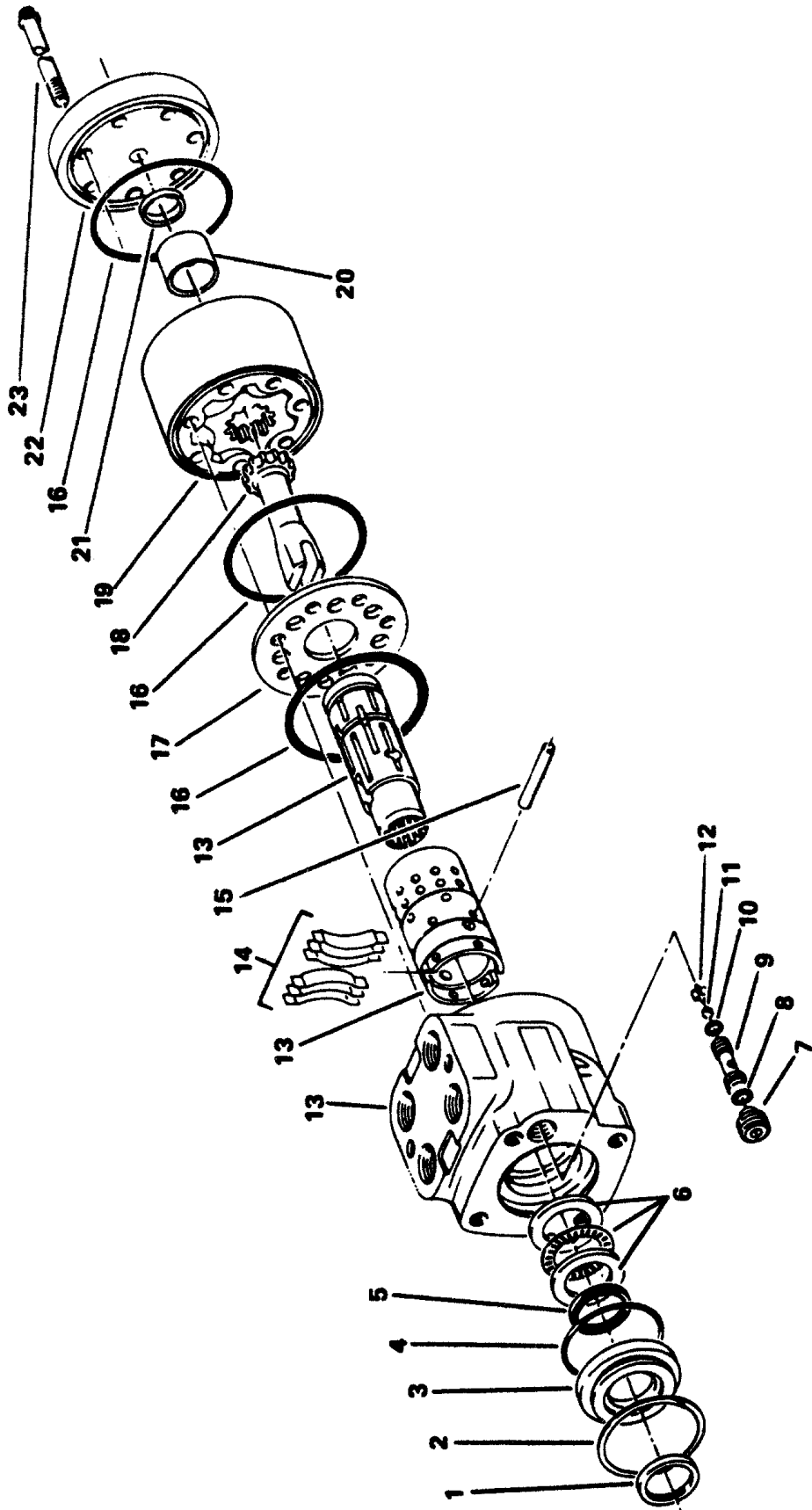

# SECTION 2 TURNTABLE

**FIGURE 2-15. STEERING VALVE ASSEMBLY**

FIG & ITEM #	PART NUMBER	DESCRIPTION	QTY.	REV.
	4640408	<b>STEERING VALVE ASSEMBLY</b>	Ref.	-
1	7000161	Seal	1	
2	7002127	Ring, Retaining	1	
3	7002128	Bushing	1	
4	Kit	Seal	1	
5	Kit	Seal	1	
6	7002171	Kit, Needle Bearing	1	
7	7002131	Setscrew	1	
8	Kit	Seal	1	
9	7002132	Seat, Check Ball	1	
10	Kit	Seal	1	
11	7002134	Ball, Check	1	
12	7002172	Retainer, Check Ball	1	
13	7002173	Control Parts Assembly	1	
14	7002174	Spring, Centering	6	
15	7002163	Pin, Centering	1	
16	Kit	Seal	3	
17	7002138	Plate, Spacer	1	
18	7002175	Drive	1	
19	7002167	Gerotor	1	
20	7002168	Spacer.480	1	
21	7002169	Spacer.140	1	
22	7002142	Cap, End	1	
23	7002170	Bolt	7	
		-----		
	2900596	Seal Kit (Includes Items 1, 4, 8, 10 and 16)	1	

SECTION 2 TURNTABLE

# SECTION 2 TURNTABLE

FIGURE 2-16. ACCESSORY VALVE ASSEMBLY (MILLER)

SECTION 2 TURNTABLE

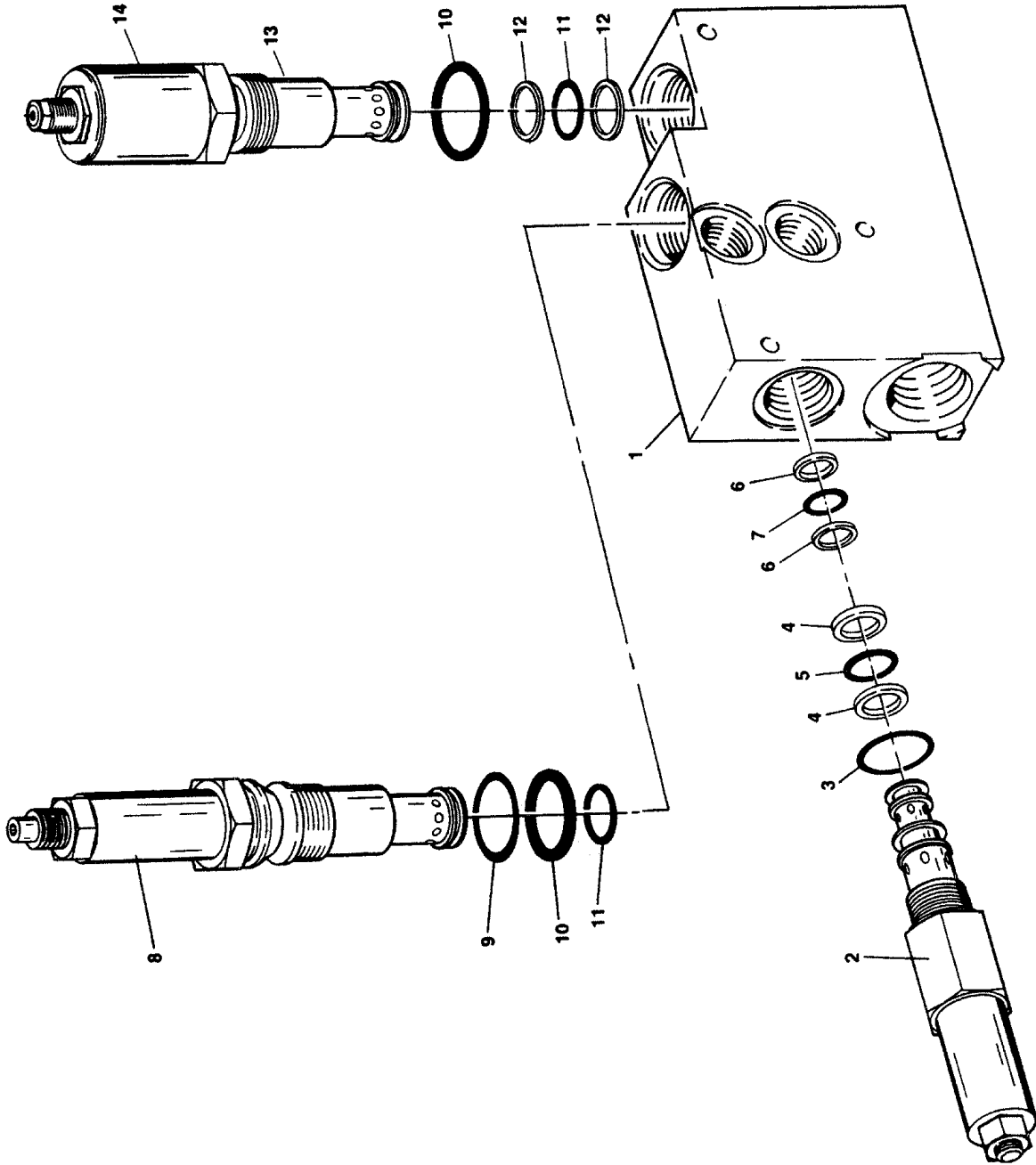

# SECTION 2 TURNTABLE

**FIGURE 2-16. ACCESSORY VALVE ASSEMBLY (MILLER)**

FIG & ITEM #	PART NUMBER	DESCRIPTION	QTY.	REV.
	4640535	<b>ACCESSORY VALVE ASSEMBLY (MILLER) (HYDRAULIC CONTROLS MACHINES BUILT THROUGH 1989)</b> <b>Note: Not sold as a complete assembly.</b>	Ref.	A
1		Body (Not Sold Separately)	1	
2	7009755	Cartridge, Pressure Reducing/Relieving	1	
3	7009759	O-Ring	1	
4	7007760	Ring, Back-Up	2	
5	3790015	O-Ring	1	
6	7009761	Ring, Back-Up	2	
7	3790014	O-Ring	1	
8	7009756	Cartridge, Sequence	1	
9	3790118	O-Ring	1	
10	3790211	O-Ring	2	
11	3790016	O-Ring	2	
12	7009762	Ring, Back-Up	2	
13	7009757	Cartridge, 2-Position	1	
14	7009758	Coil (Includes Nut and Washer)	1	

**SECTION 2 TURNTABLE**

# SECTION 2 TURNTABLE

FIGURE 2-17. ACCESSORY VALVE ASSEMBLY (HYDRAFORCE)

SECTION 2 TURNTABLE

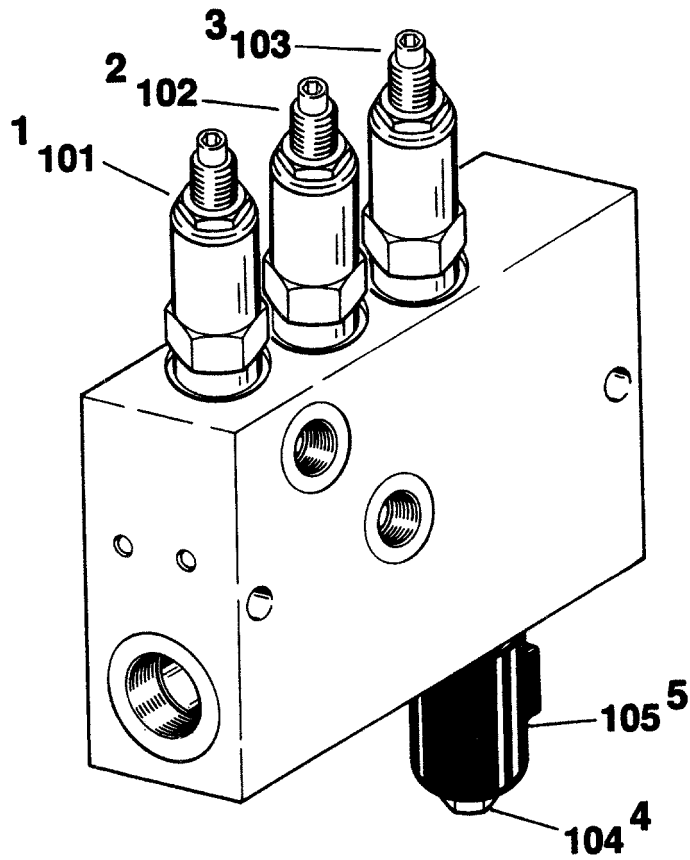

# SECTION 2 TURNTABLE

**FIGURE 2-17. ACCESSORY VALVE ASSEMBLY (HYDRAFORCE)**

FIG & ITEM #	PART NUMBER	DESCRIPTION	QTY.	REV.
	4640580	<b>ACCESSORY VALVE ASSEMBLY (HYDRAFORCE) (HYDRAULIC CONTROLS MACHINES BUILT 1990 TO SEPTEMBER 1991)</b> <b>Note: Not sold as a complete assembly.</b>	Ref.	-
1	7004365	Cartridge - Sequence	1	
2	7004366	Cartridge - Pressure Reducing	1	
3	7004367	Cartridge - Main Relief	1	
4	7004369	Cartridge Less Coil - Dump	1	
5	7004368	Coil	1	
		-----		
	2900707	Seal Kit (Sequence and Pressure Reducing)	2	
	2900708	Seal Kit (Main Relief)	1	
	2900709	Seal Kit (Dump)	1	
	4640716	<b>ACCESSORY VALVE ASSEMBLY (HYDRAULIC CONTROLS MACHINES BUILT SEPTEMBER 1991 TO PRESENT)</b> <b>Note: Refer to P/N stamped on cartridge hex nut for identification.</b>	Ref.	-
			Ref.	-
101	7012506	Cartridge - Sequence (Hydraforce PS10-34A)	1	
	7010552	Cartridge - Sequence (Vickers/Modular Controls PSV7-10V)	1	
102	7012505	Cartridge - Pressure Reducing (Hydraforce PR10-32a)	1	
	7010553	Cartridge - Pressure Reducing (Vickers/Modular Controls PRV1-10V)	1	
103	7012507	Cartridge - Main Relief (Hydraforce RV50-26A)	1	
	7010554	Cartridge - Main Relief (Vickers/Modular Controls RV5-10V)	1	
104	7004369	Cartridge Less Coil - Dump (Hydraforce SV16-21)	1	
105	7004368	Coil (Hydraforce 6352012)	1	
104	7010556	Cartridge w/Coil - Dump (Vickers/Modular Controls SV3-16V)	1	
105	7010555	Coil (Vickers/Modular Controls 565966)	1	
		-----		
	7012509	Seal Kit (Sequence) (Hydraforce Version)	1	
	7010557	Seal Kit (Sequence) (Vickers/Modular Controls Version)	1	
	7012510	Seal Kit (Pressure Reducing) (Hydraforce Version)	1	
	7010558	Seal Kit (Pressure Reducing) (Vickers/Modular Controls Version)	1	
	7012511	Seal Kit (Main Relief) (Hydraforce Version)	1	
	7010559	Seal Kit (Main Relief) (Vickers/Modular Controls Version)	1	
	2900709	Seal Kit (Dump) (Hydraforce Version)	1	
	7010560	Seal Kit (Dump) (Vickers/Modular Controls Version)	1	

**SECTION 2 TURNTABLE**

# SECTION 2 TURNTABLE

FIGURE 2-18. SWING DRIVE, BEARING AND LOCK INSTALLATIONS

SECTION 2 TURNTABLE

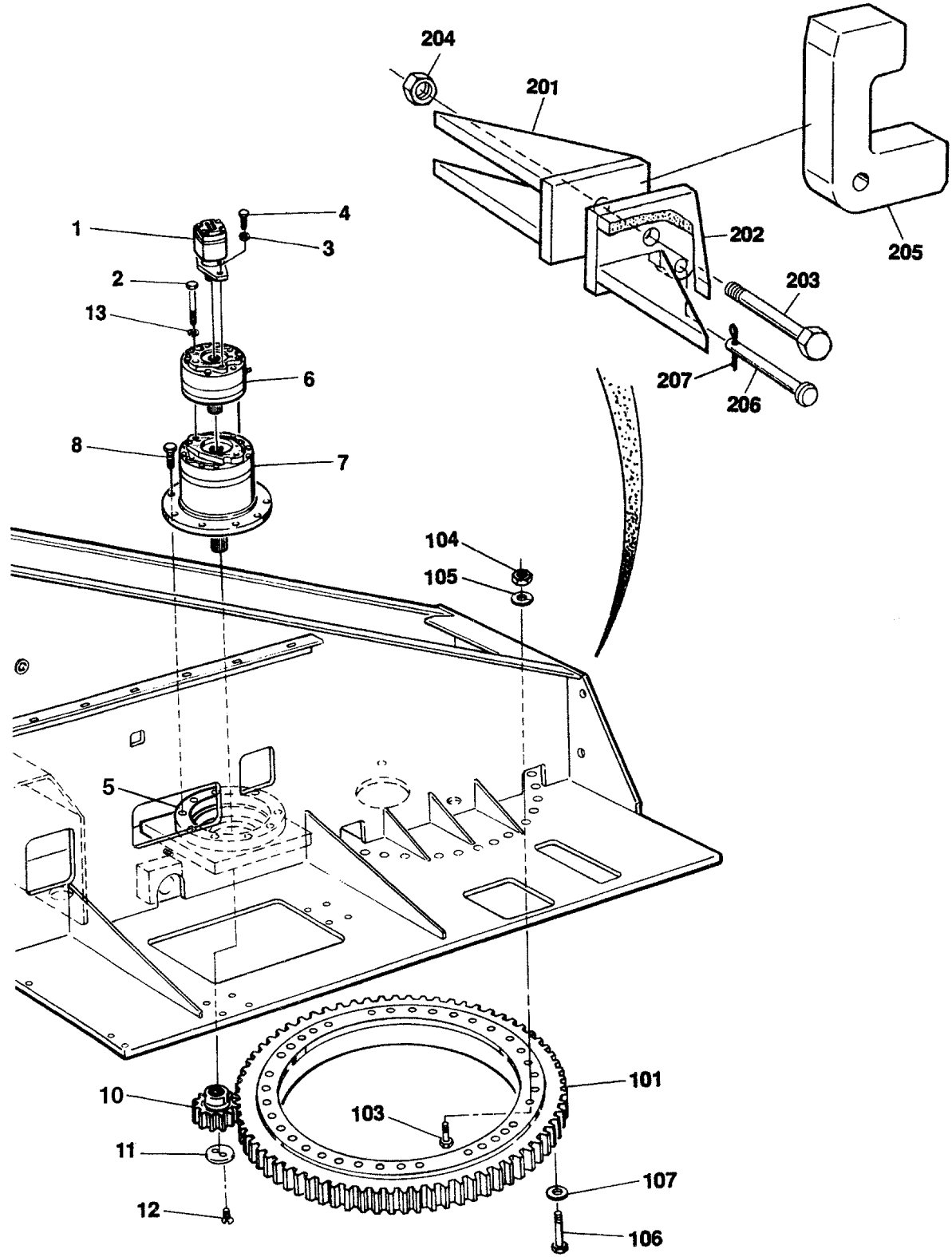



# SECTION 2 TURNTABLE

**FIGURE 2-18. SWING DRIVE, BEARING AND LOCK INSTALLATIONS**

FIG & ITEM #	PART NUMBER	DESCRIPTION	QTY.	REV.
		<b>SWING DRIVE, BEARING AND LOCK INSTALLATIONS</b>	Ref.	
	0236519	<b>SWING DRIVE INSTALLATION - MACHINES BUILT PRIOR TO NOVEMBER 1991</b>	Ref.	E
	0252347	<b>SWING DRIVE INSTALLATION - MACHINES (WITH MILLED T/T) BUILT NOVEMBER 1991 TO PRESENT</b>	Ref.	3
1	3160114	Swing Motor Assembly (See Figure 2-19 for Breakdown)	1	
2	3931864	Bolt, Socket Head 1/2"-13NC x 4"	2	
3	4761800	Lockwasher 1/2"	2	
4	0641812	Bolt 1/2"-13NC x 1 1/2"	2	
5		Plate, Drive Mounting Options:	1	
	Use 1001120496	Prior to November 1991 (was p/n 0236421)		
	3760300	November 1991 to Present		
6		Swing Brake Assembly Options:	1	
	0920032	(Prior to April 1992) (See Figure 2-20 for Breakdown)		
	0920083	(April 1992 to S/N 33476) (See Figure 2-21 for Breakdown)		
	0920109	(S/N 33476 to Present) (See Figure 2-21 for Breakdown)		
7	2780055	Swing Hub Assembly (See Figure 2-22 for Breakdown)	1	
8	0641912	Bolt 9/16"-12 x 1 1/2"	9	
9	0100019	Loctite #271 (Not Shown)	A/R	
10		Gear, Pinion Options:	1	
	2440045	Prior to November 1991		
	2440062	November 1991 to Present		
11	3501916	Plate, Retaining	1	
12	0741606	Screw, Flat Head 3/8"-16NC x 3/4"	2	
13	4740189	Washer, Special	2	
14	0100009	Sealant, Pipe (Not Shown)	A/R	
	0236265	<b>TURNTABLE BEARING INSTALLATION</b>	Ref.	F
101	0440189	Bearing	1	
102	0100004	Devcon (Required Prior to November 1991) (Not Shown)	A/R	
103	0682018	Bolt 5/8"-11NC x 2 1/4"	36	
104	3300183	Nut, Special	36	
105	4740004	Washer, Special	36	
106	0681816	Bolt 1/2"-13NF x 2"	36	
107	4740003	Washer, Special	36	
108	0100011	Loctite #271 (Not Shown)	A/R	
109	1300010	Solvent, Safety (Not Shown)	A/R	

# SECTION 2 TURNTABLE

**FIGURE 2-18. SWING DRIVE, BEARING AND LOCK INSTALLATIONS (CONTINUED)**

FIG & ITEM #	PART NUMBER	DESCRIPTION	QTY.	REV.
	0236106	<b>TURNTABLE LOCK INSTALLATION</b>	Ref.	D
201	4340398	Support Weldment (Right)	1	
202	4340397	Support Weldment (Left)	1	
203	0642022	Bolt 5/8"-11NC x 2 3/4"	1	
204	3312005	Locknut 5/8"-11NC	1	
205	3420761	Pin, Locking	1	
206	3420620	Pin, Clevis	1	
207	3420182	Pin, Cotter	1	

**SECTION 2 TURNTABLE**

# SECTION 2 TURNTABLE

FIGURE 2-18. SWING DRIVE, BEARING AND LOCK INSTALLATIONS (CONTINUED)

FIG & ITEM #	PART NUMBER	DESCRIPTION	QTY.	REV.

**S  
E  
C  
T  
I  
O  
N  
  
2  
  
T  
U  
R  
N  
T  
A  
B  
L  
E**

# SECTION 2 TURNTABLE

FIGURE 2-19. SWING MOTOR ASSEMBLY

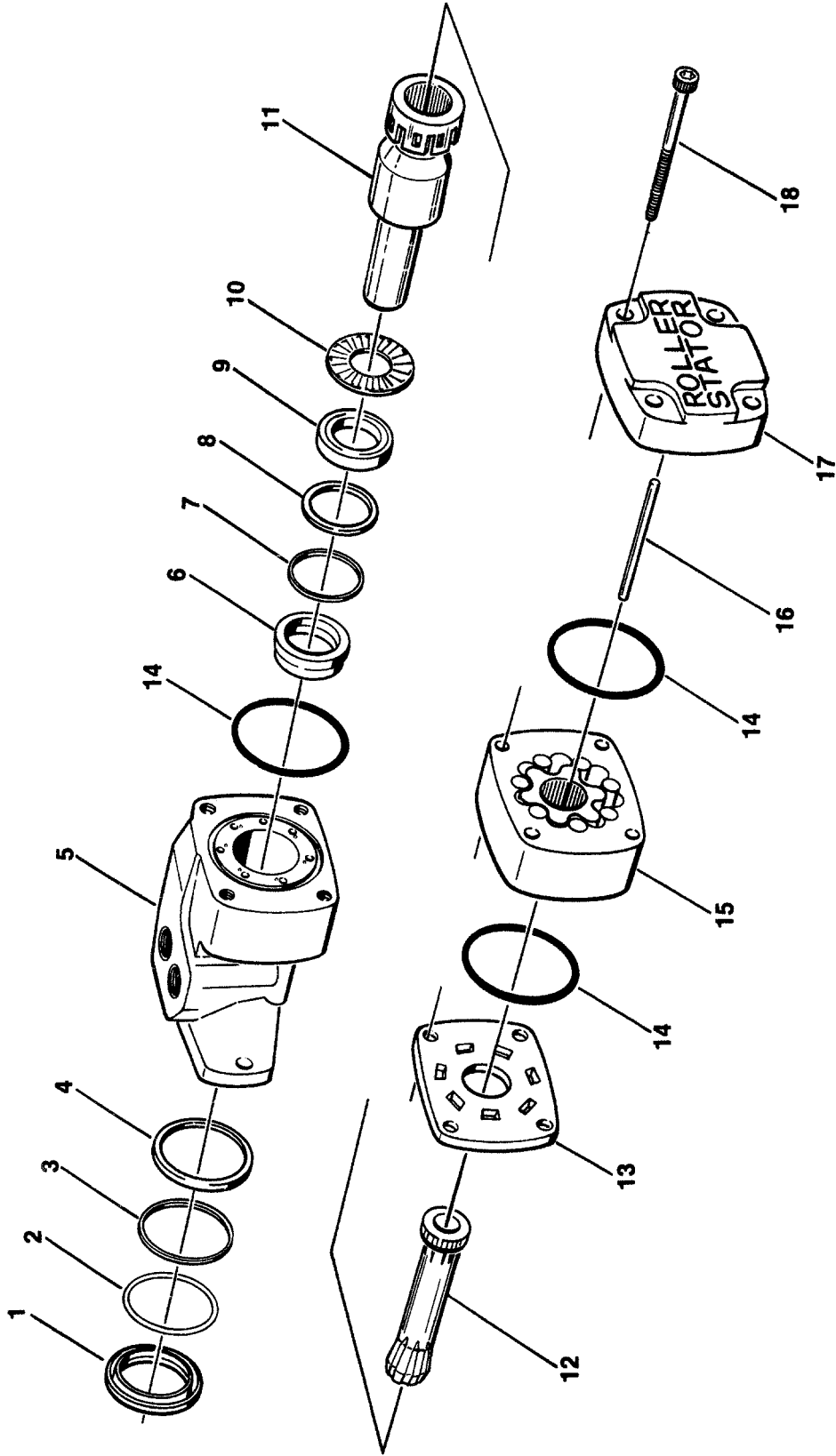

SECTION 2 TURNTABLE

# SECTION 2 TURNTABLE

**FIGURE 2-19. SWING MOTOR ASSEMBLY**

FIG & ITEM #	PART NUMBER	DESCRIPTION	QTY.	REV.
	3160114	<b>SWING MOTOR ASSEMBLY</b>	Ref.	A
1	Kit	Seal, Dust	1	
2	Kit	Ring, Wire	1	
3	Kit	Shim	1	
4	Kit	Seal	1	
5	7005818	Housing	1	
6	Kit	Seal, Carrier	1	
7	Kit	Shim	1	
8	Kit	Leather Back-up	1	
9	Kit	Seal, Shaft	1	
10	7005809	Bearing, Thrust	1	
11	7005810	Shaft RS	1	
12	7005811	Link, Drive	1	
13	7005812	Plate, Wear	1	
14	Kit	Seal	3	
15	7005819	Stator, Roller	1	
16	7005820	Pin, Dowel	1	
17	7005816	Cover, End	1	
18	7005821	Bolt	4	
		-----		
	2900477	Seal Kit (Consisting of Items 1, 2, 3, 4, 5, 6, 8, 9 and 14)	1	

**SECTION 2 TURNTABLE**

# SECTION 2 TURNTABLE

FIGURE 2-20. SWING BRAKE ASSEMBLY (PRIOR TO APRIL 1992)

SECTION 2 TURNTABLE

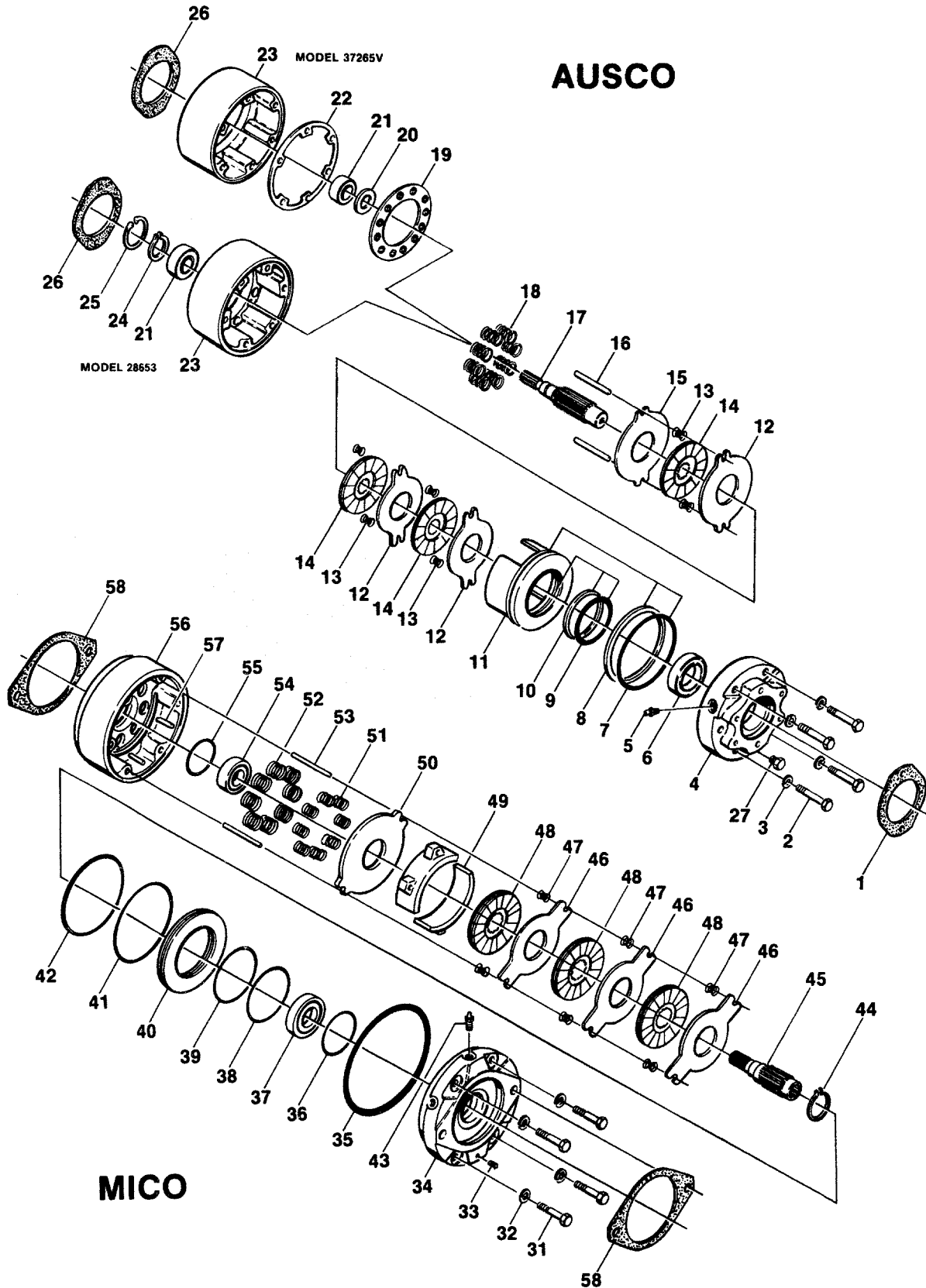

# SECTION 2 TURNTABLE

**FIGURE 2-20. SWING BRAKE ASSEMBLY (PRIOR TO APRIL 1992)**

FIG & ITEM #	PART NUMBER	DESCRIPTION	QTY.	REV.
	0920032	<b>SWING BRAKE ASSEMBLY (PRIOR TO APRIL 1992)</b>	Ref.	-
	0920032	<b>SWING BRAKE ASSEMBLY - AUSCO (MODEL 28653)</b>	Ref.	-
	0920032	<b>SWING BRAKE ASSEMBLY - AUSCO (MODEL 37265V)</b>	Ref.	C
		<b>Note: Used Prior to April 1992 on 60H, 60H+6 and 70H Models.</b>		
		<b>Note: Refer to Model Number stamped on the front of the Housing Item 23.</b>		
1	Kit	Gasket	1	
2	7000730	Bolt (Model 38653)	4	
	7003007	Bolt, Flanged (Model 37265V)	4	
3	7000729	Lockwasher (Model 28653 Only)	4	
4	7003012	Plate, Power (Model 38653)	1	
	7003091	Plate, Power (Model 37265V)	1	
5	7000796	Bleeder	1	
6	7000760	Bearing, Ball (Model 37265V Only)	1	
7	Kit	O-Ring	1	
8	Kit	Ring, Back-up	1	
9	Kit	O-Ring	1	
10	Kit	Ring, Back-up	1	
11	7000721	Piston (Model 28653)	1	
	7003057	Piston (Model 37265V)	1	
12	7000720	Disc, Stationary (Model 28653)	3	
	7003056	Disc, Stationary (Model 37265V)	3	
13	7003006	Spring, Compression	6	
14	7000732	Disc, Rotating (Model 28653)	3	
	7003055	Disc, Rotating (Model 37265V)	3	
15	7000718	Disc, Primary (Model 28653)	1	
	7003054	Disc, Primary (Model 37265V)	1	
16	7000717	Pin, Torque	2	
17	7003013	Shaft, Splined (Model 28653)	1	
	7003053	Shaft, Splined (Model 37265V)	1	
18	7000798	Spring, Compression (Model 28653)	8	
	7003052	Spring, Compression (Model 37265V)	8	
19	7003051	Retainer, Spring (Model 37265V Only)	1	
20	Kit	Seal, Oil	1	
21	7000713	Bearing, Ball (Model 28653)	1	
	7003049	Bearing, Ball (Model 37265V)	1	
22	Kit	Gasket (Model 37265V Only)	1	
23	7000714	Housing (Model 28653)	1	
	7003090	Housing (Model 37265V)	1	
24	7000712	Ring, Retaining (Model 28653 Only)	1	
25	7000711	Ring, Retaining (Model 28653 Only)	1	
26	Kit	Gasket	1	
27	7003059	Valve, Pressure Relief (Model 37265V Only)	1	
28	Not Used			

**SECTION 2 TURNTABLE**

# SECTION 2 TURNTABLE

**FIGURE 2-20. SWING BRAKE ASSEMBLY (PRIOR TO APRIL 1992) (CONTINUED)**

FIG & ITEM #	PART NUMBER	DESCRIPTION	QTY.	REV.
29	Not Used			
30	Not Used			
	2900131	Seal Kit (Includes Items 1, 7, 8, 9, 10, 20, 22 and 26)		
	0920032	<b>SWING BRAKE ASSEMBLY - MICO</b> <b>Note: Used Prior to April 1992 on 60H, 60H+6 and 70H Models.</b>	Ref.	B
31	7007913	Capscrew	4	
32	7007912	Lockwasher	4	
33	7007924	Plug	1	
34	7007928	Cover	1	
35	Kit	Ring, Square	1	
36	Kit	O-Ring	1	
37	Kit	Bearing	1	
38	Kit	O-Ring	1	
39	Kit	Ring, Back-Up	1	
40	7007923	Piston	1	
41	Kit	O-Ring	1	
42	Kit	Ring, Back-Up	1	
43	7007914	Bleeder	1	
44	Kit	Ring, Retaining	1	
45	7007926	Shaft	1	
46	7007908	Disc	3	
47	7007916	Spring	6	
48	7007909	Disc, Friction	3	
49	7007902	Separator	2	
50	7007907	Disc	1	
51	7007906	Spring	8	
52	7007905	Spring	8	
53	7007915	Pin, Dowel	2	
54	Kit	Bearing	1	
55	Kit	O-Ring	1	
56	7007930	Housing	1	
57	7007901	Pin, Spiral	4	
58	7007933	Gasket	1	
	7007934	Gasket	1	
	2900642	Seal Kit (Includes Items 35, 36, 38, 39, 41, 42, 55 and 58 Gaskets)	1	
	7007927	Bearing Kit (Includes Items 36, 37, 44, 54, 55 and 58 Gasket)	1	

**SECTION 2 TURNTABLE**



# SECTION 2 TURNTABLE

FIGURE 2-20. SWING BRAKE ASSEMBLY (PRIOR TO APRIL 1992) (CONTINUED)

FIG & ITEM #	PART NUMBER	DESCRIPTION	QTY.	REV.

**S  
E  
C  
T  
I  
O  
N  
  
2  
  
T  
U  
R  
N  
T  
A  
B  
L  
E**

# SECTION 2 TURNTABLE

FIGURE 2-21. SWING BRAKE ASSEMBLY (APRIL 1992 TO PRESENT)

SECTION 2 TURNTABLE

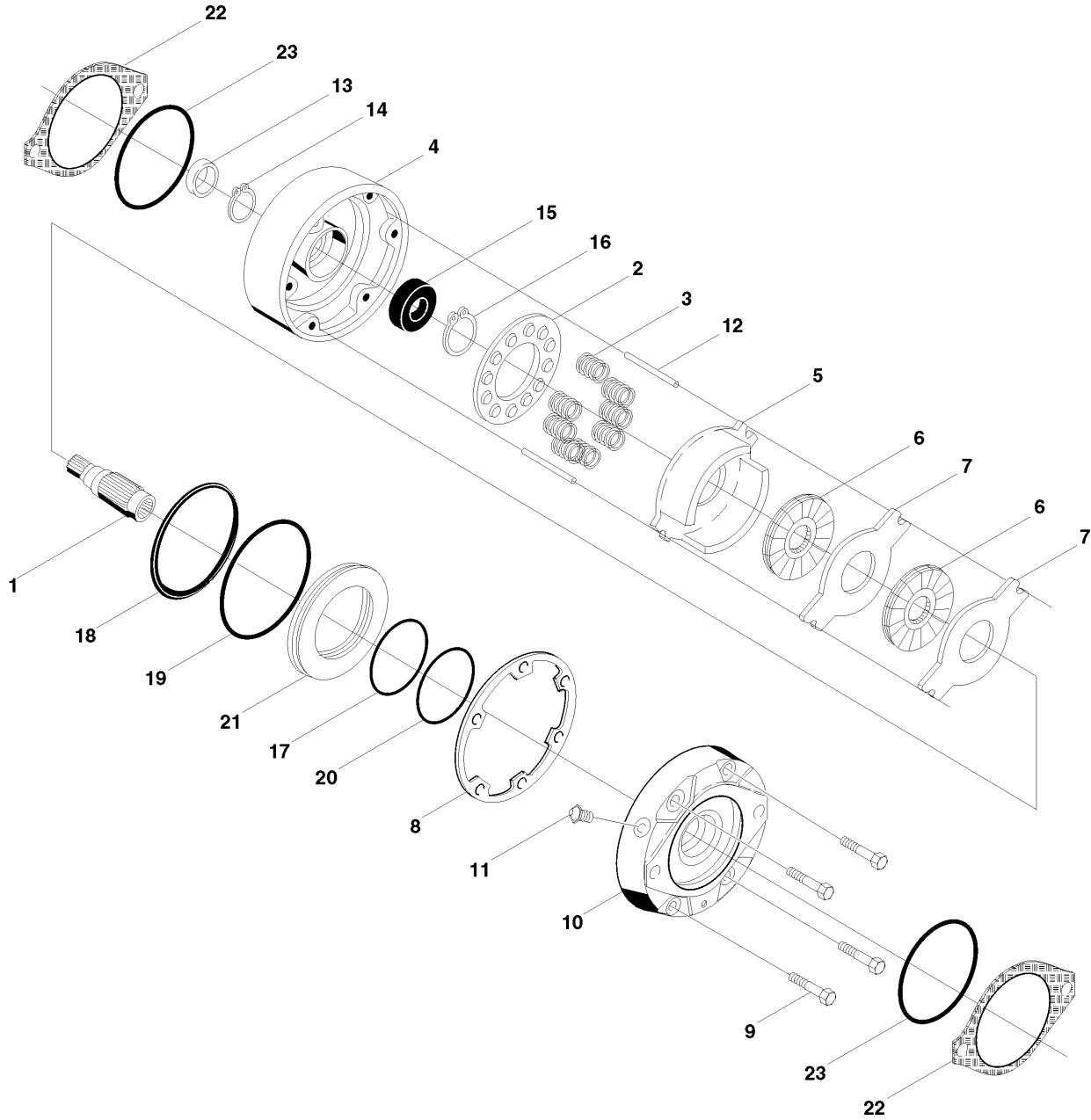

# SECTION 2 TURNTABLE

**FIGURE 2-21. SWING BRAKE ASSEMBLY (APRIL 1992 TO PRESENT)**

FIG & ITEM #	PART NUMBER	DESCRIPTION	QTY.	REV.
		<b>SWING BRAKE ASSEMBLIES</b>	Ref.	
	0920083	<b>Prior to S/N 33476</b>	Ref.	A
	0920109	<b>S/N 33476 to S/N 64566</b>	Ref.	B
		<b>Note: Used April 1992 to Present on 60H, 60H+6 and 70H Models.</b>	Ref.	
1		Shaft Options:	1	
	7011718	Machines Built Through 1992		
	7011720	Machines Built 1993 to Present		
2		Guide, Spring Options:	1	
	Not Required	0920083 Brake (Machines Built Through 1992)		
	7011717	0920083 Brake (Machines Built 1993 to S/N 33476)		
	7018606	0920109 Brake (S/N 33476 to Present)		
3		Spring Options:	A/R	
	7007979	0920083 Brake (Inner) (Prior to S/N 33476)	6	
	7007980	0920083 Brake (Outer) (Prior to S/N 33476)	6	
	7007970	0920109 Brake (Red) (S/N 33476 to Present)	6	
	7018602	0920109 Brake (Blue) (S/N 33476 to Present)	3	
4		Housing Options:	1	
	7007981	0920083 Brake (Machines Built Through 1992)		
	7011713	0920083 Brake (Machines Built 1993 to S/N 33476)		
	7018605	0920109 Brake (S/N 33476 to Present)		
5		Return Plate & Separator Assembly Options:	A/R	
	Kit	Plate, Return - 0920083 Brake (Prior to S/N 33476)	1	
	7011715	Separator Assy - 0920083 Brake (Prior to S/N 33476)	2	
	7011714	Pin	4	
	7007983	Separator	2	
	Kit	Plate, Return/Separator - 0920109 Brake (S/N 33476 to Present)	1	
6	Kit	Rotor	2	
7	Kit	Stator	2	
8	Kit	Seal, Oil	1	
9		Bolt, Washer Head Options:	4	
	7007985	0920083 Brake (Prior to S/N 33476)		
	7018607	0920109 Brake (S/N 33476 to Present)		
10	7011719	Cover	1	
11		Hardware Options:	1	
	7007914	Screw, Bleeder (Prior to S/N 33906)		
	7018609	Plug, Pipe (S/N 33906 to Present)		
12	7007987	Pin, Dowel	2	
13	Kit	Seal, Oil	1	
14		Ring, Retaining Options:	1	
	Not Required	Machines Built Through 1992		
	7011716	Machines Built 1993 to Present		
15	Kit	Bearing	1	
16	7007977	Ring, Retaining	1	

**SECTION 2 TURNTABLE**

# SECTION 2 TURNTABLE

**FIGURE 2-21. SWING BRAKE ASSEMBLY (APRIL 1992 TO PRESENT) (CONTINUED)**

FIG & ITEM #	PART NUMBER	DESCRIPTION	QTY.	REV.
17	Kit	Ring, Back-Up	1	
18	Kit	Ring, Back-Up	1	
19	Kit	O-Ring	1	
20	Kit	O-Ring	1	
21		Piston Options:	1	
	7007923	0920083 Brake (Prior to S/N 33476)		
	7018603	0920109 Brake (S/N 33476 to Present6)		
22	7007934	Gasket	2	
23	Kit	O-Ring	2	
	2900766	Seal Kit (Includes Items 8,13,17,18,19,20,22 & 23)	1	
	2900768	Bearing Kit (Includes Items 8,13,14,15,16,22 & 23)	1	
		Lining Kit Options:		
	2900767	0920083 Brake (Prior to S/N 33476)		
	7018608	0920109 Brake (S/N 33476 to Present)		

**SECTION 2 TURNTABLE**

# SECTION 2 TURNTABLE

FIGURE 2-21. SWING BRAKE ASSEMBLY (APRIL 1992 TO PRESENT) (CONTINUED)

FIG & ITEM #	PART NUMBER	DESCRIPTION	QTY.	REV.

**S  
E  
C  
T  
I  
O  
N  
  
2  
  
T  
U  
R  
N  
T  
A  
B  
L  
E**

# SECTION 2 TURNTABLE

FIGURE 2-22. SWING HUB ASSEMBLY

SECTION 2 TURNTABLE

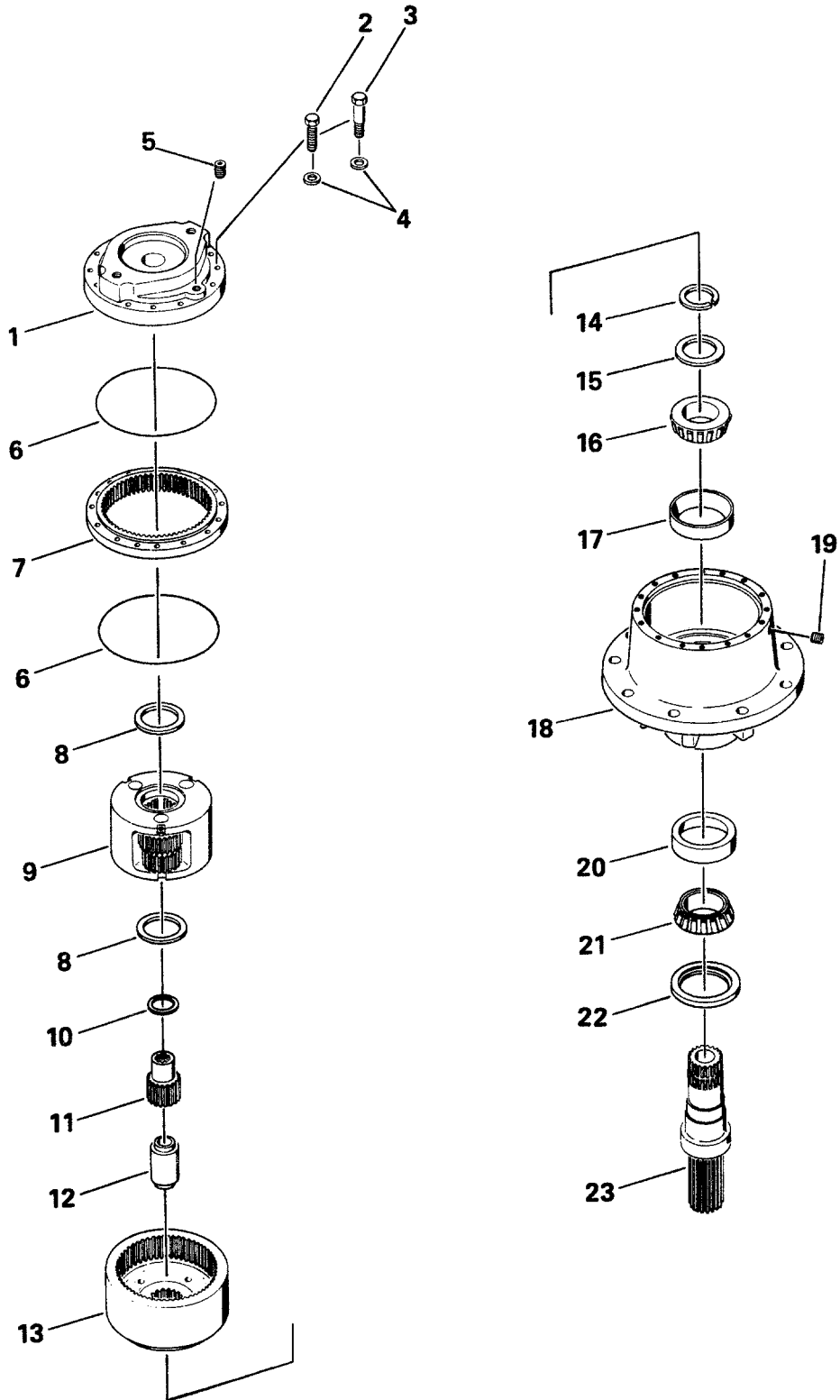

# SECTION 2 TURNTABLE

**FIGURE 2-22. SWING HUB ASSEMBLY**

FIG & ITEM #	PART NUMBER	DESCRIPTION	QTY.	REV.
	2780055	<b>SWING HUB ASSEMBLY</b>	Ref.	-
1	7000209	Cover	1	
2	7000217	Bolt, Hex Head	8	
3	7000214	Bolt, Hex Head, Shoulder	4	
4	4751500	Flatwasher	12	
5	7000242	Plug, Pipe	1	
6	Kit	O-Ring	2	
7	7000208	Gear, Ring	1	
8	7000253	Washer, Thrust	2	
9	7000207	Planet Carrier Assembly (No Service Breakdown Parts Purchase Entire Assembly)	1	
10	7000270	Washer, Thrust	1	
11	7000268	Gear, Sun-Input	1	
12	7000269	Spacer, Sun Gear	1	
13	7000246	Gear, Internal	1	
	7000271	Hub Assembly	1	
14	Kit	Ring, Retaining	1	
15	Kit	Spacer	1	
16	7000258	Bearing, Tapered Roller	1	
17	7000257	Cup, Bearing	1	
18	7000210	Hub	1	
19	7000242	Plug, Pipe	1	
20	7000255	Cup, Bearing	1	
21	7000256	Bearing, Tapered Roller	1	
22	Kit	Seal	1	
23	7000233	Shaft, Output	1	
	2900034	----- Kit, Repair (Includes Items 6, 14, 15 and 22)	1	

SECTION 2 TURNTABLE

# SECTION 2 TURNTABLE

FIGURE 2-23. ROTARY COUPLING AND COLLECTOR RING ASSEMBLY AND INSTALLATION

SECTION 2 TURNTABLE

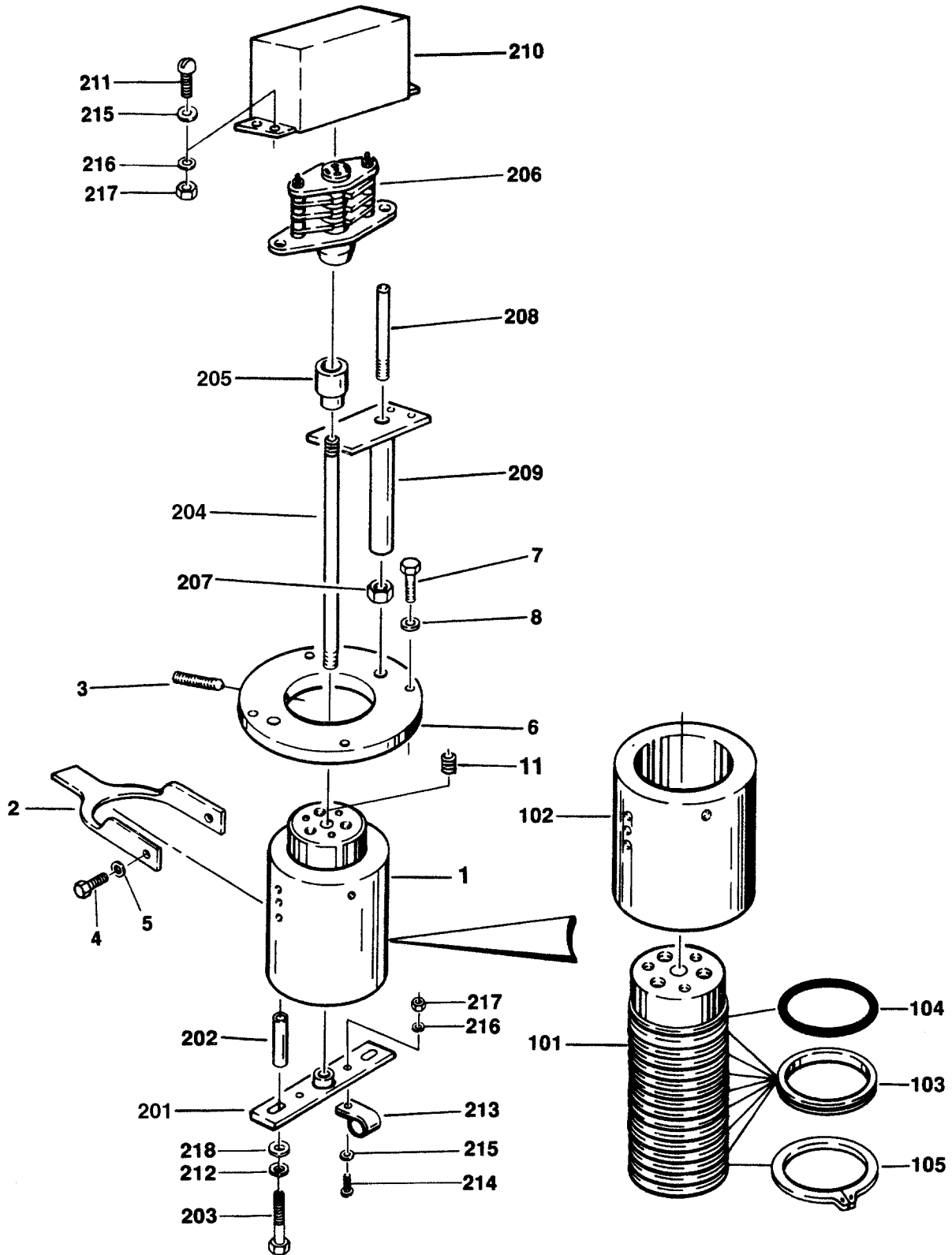



# SECTION 2 TURNTABLE

**FIGURE 2-23. ROTARY COUPLING AND COLLECTOR RING ASSEMBLY AND INSTALLATION**

FIG & ITEM #	PART NUMBER	DESCRIPTION	QTY.	REV.
		<b>ROTARY COUPLING AND COLLECTOR RING ASSEMBLY AND INSTALLATION</b>	Ref.	
		<b>ROTARY OIL COUPLING INSTALLATION (STANDARD PARTS)</b>	Ref.	
	0230153	<b>ROTARY OIL COUPLING INSTALLATION - MACHINES WITH RACINE VALVES AND SINGLE SPEED DRIVE MOTORS</b>	Ref.	-
	0234479	<b>ROTARY OIL COUPLING INSTALLATION - MACHINES WITH RACINE VALVES AND 2 SPEED DRIVE MOTORS</b>	Ref.	I
	0238032	<b>ROTARY OIL COUPLING INSTALLATION - MACHINES WITH VICKERS VALVES AND OPTIONAL 4WD/2WS ONLY</b>	Ref.	-
	0250611	<b>ROTARY OIL COUPLING INSTALLATION - MACHINES WITH VICKERS VALVES AND OPTIONAL 2WD/4WS OR 4WD/4WS ONLY</b>	Ref.	C
1		Oil Coupling Assembly Options (See Items 101-105 for Breakdown):	1	
	1660154	Machines with Racine Valves & Single Speed Drive Motors (5 Port)		
	1660154	Machines with Racine Valves & 2 Speed Drive Motors (5 Port)		
	1660160	Machines with Vickers Valves & Optional 4WD/2WS (6 Port)		
	1660185	Machines with Vickers Valves & Optional 2WD/4WS or 4WD/4WS Only (6 Port)		
2	3530403	Plate, Retaining	1	
3	3951820	Setscrew 1/2" - 13NC x 2 1/2"	2	
4	0641807	Bolt 1/2"-13NC x 7/8"	2	
5	4761800	Lockwasher 1/2"	2	
6	1440154	Collar	1	
7	0641512	Bolt 5/16"-18NC x 1 1/2"	4	
8	4761500	Lockwasher 5/16"	4	
9	0100011	Loctite #242 (Not Shown)	A/R	
10	0100019	Loctite #271 (Not Shown)	A/R	
11	2200202	Plug, Pipe (Used when not equipped with Collector Ring)	1	
		<b>ROTARY OIL COUPLING ASSEMBLIES</b>	Ref.	
101		Swivel Body Options:	1	
	0620055	Body for 1660154 Coupling		
	0620058	Body for 1660160 Coupling		
	0620106	Body for 1660185 Coupling		
102		Swivel Housing Options:	1	
	2760025	Housing for 1660154 Coupling		
	2760091	Housing for 1660160 and 1660185 Couplings		
103	Kit	T-Seal	7	
104	3760004	Ring, Retaining	1	

# SECTION 2 TURNTABLE

**FIGURE 2-23. ROTARY COUPLING AND COLLECTOR RING ASSEMBLY AND INSTALLATION**

FIG & ITEM #	PART NUMBER	DESCRIPTION	QTY.	REV.
105	Kit	O-Ring	1	
		-----		
		Seal Kit Options:	1	
	2901146	1660154, 1660160 & 1660185 Coupling (Includes Items 103 & 105)		
	Use 1660213EX	1660213 Coupling (was p/n 7013175)		
		<b>Note: Due to Complexity of repair, seal kit no longer available. Use rebuilt unit as replacement.</b>		
	0232123	<b>COLLECTOR RING INSTALLATION - 4WD/2WS MACHINES ONLY</b>	Ref.	7
	0251561	<b>COLLECTOR RING INSTALLATION - 4WD/4WS AND 2WD/4WS MACHINES ONLY</b>	Ref.	B
201		Bracket Weldment Options:	1	
	0230470	Bracket Weldment - 4WD/2WS		
	4843822	Bracket Weldment - 4WD/4WS & 2WD/4WS		
202	0960224	Bushing	2	
203	0641418	Bolt 1/4"-20NC x 2 1/4"	2	
204		Pipe Options:	1	
	3460065	Pipe - 4WD/2WS		
	2180763	Pipe - 4WD/4WS & 2WD/4WS		
205		Bushing Options:	1	
	0230435	Bushing - 4WD/2WS		
	0961531	Bushing - 4WD/4WS & 2WD/4WS		
206	3760053	Collector Ring Assembly	1	
207	3311801	Nut 1/2"-13NC	2	
208	3420290	Pin, Drive	2	
209	0231047	Guide, Drive	2	
210	1670594	Cover	1	
211	0721005	Screw, Machine #10-24NC x 5/8"	4	
212	4761400	Lockwasher 1/4"	2	
213	1320040	Clamp, Cable	2	
214	3911012	Screw, Machine	1	
215	4751000	Flatwasher #10	6	
216	4761000	Lockwasher #10	5	
217	3311001	Nut #10-24NC	5	
218	4751400	Flatwasher 1/4"	2	

**SECTION 2 TURNTABLE**

# SECTION 2 TURNTABLE

FIGURE 2-23. ROTARY COUPLING AND COLLECTOR RING ASSEMBLY AND INSTALLATION

FIG & ITEM #	PART NUMBER	DESCRIPTION	QTY.	REV.

**S  
E  
C  
T  
I  
O  
N  
  
2  
  
T  
U  
R  
N  
T  
A  
B  
L  
E**

# SECTION 2 TURNTABLE

FIGURE 2-24. DEUTZ ENGINE INSTALLATION WITHOUT NOISE REDUCTION  
(BUILT PRIOR TO DECEMBER 1992)

SECTION 2 TURNTABLE

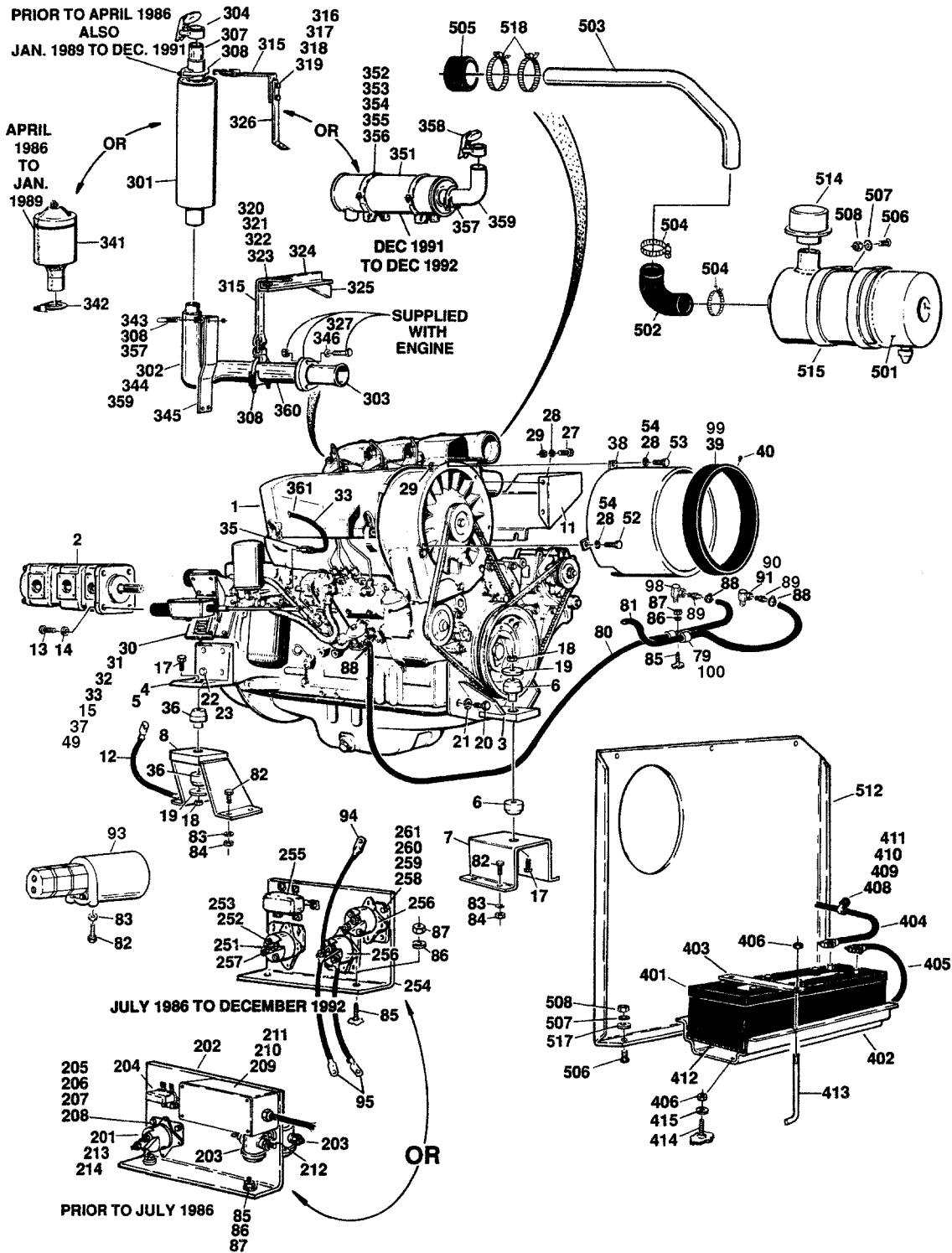

# SECTION 2 TURNTABLE

**FIGURE 2-24. DEUTZ ENGINE INSTALLATION WITHOUT NOISE REDUCTION (BUILT PRIOR TO DECEMBER 1992)**

FIG & ITEM #	PART NUMBER	DESCRIPTION	QTY.	REV.
		<b>DEUTZ ENGINE INSTALLATION WITHOUT NOISE REDUCTION (BUILT PRIOR TO DECEMBER 1992)</b>	Ref.	
	0236375	<b>DEUTZ F3L912 ENGINE ASSEMBLY - MACHINES WITH RACINE PROPORTIONAL VALVES AND SINGLE SPEED DRIVE</b>	Ref.	G
	0237287	<b>DEUTZ F3L912 ENGINE ASSEMBLY - MACHINES WITH RACINE PROPORTIONAL VALVES AND TWO SPEED DRIVE</b>	Ref.	D
	0237997	<b>DEUTZ F3L912 ENGINE ASSEMBLY - MACHINES WITH VICKERS PROPORTIONAL VALVES AND STANDARD ENGINE</b>	Ref.	I
	0238024	<b>DEUTZ ENGINE ASSEMBLY - MACHINES WITH VICKERS PROPORTIONAL VALVES AND CLEAN BURN ENGINE</b>	Ref.	G
	0238022	<b>DEUTZ F4L912 ENGINE ASSEMBLY - MACHINES WITH VICKERS PROPORTIONAL VALVES AND STANDARD ENGINE</b>	Ref.	J
1		Engine Assembly Options:	1	
	2000066	Engine Assembly - F3L912 Standard		
	2000094	Engine Assembly - F3L912W Clean Burn		
	2000083	Engine Assembly - F4L912 Standard		
2		Pump Assembly Options:		
	3600107	Machines with Racine Proportional Valves & Single Speed Drive (See Figure 2-37 for Breakdown)	1	
	3600113	Machines with Racine Proportional Valves & Two Speed Drive (See Figure 2-37 for Breakdown)	1	
		Machines with Vickers Proportional Valves Options:		
	3600072	Pump with 1 Outlet in End Cover (Prior to Mid 1987) (See Figure 2-38 for Breakdown)		
	3600139	Pump with 2 Outlets in End Cover (Mid 1987 to December 1992) (See Figure 2-39 for Breakdown)		
3	4842079	Support, Motor (Front)	1	
4	0181158	Support, Motor (Rear Left Side)	1	
5	0181159	Support, Motor (Rear Right Side)	1	
6	3200133	Mount, Engine (Front)	1	
7	3200206	Bracket, Mounting (Front)	1	
8	4842167	Bracket, Mounting (Rear)	2	
9	Not Used			
10	Not Used			
11		Deflector Options:	1	
	4060580	Deutz F3L912 Engine		
	4060610	Deutz F4L912 Engine		
12	1060044	Cable, Battery (Start Solenoid to Ground)	1	
13	0641810	Bolt 1/2" - 18NC x 1 1/4"	2	
14	4761800	Lockwasher 1/2"	2	

**SECTION 2 TURNTABLE**

# SECTION 2 TURNTABLE

**FIGURE 2-24. DEUTZ ENGINE INSTALLATION WITHOUT NOISE REDUCTION (BUILT PRIOR TO DECEMBER 1992) (CONTINUED)**

FIG & ITEM #	PART NUMBER	DESCRIPTION	QTY.	REV.
15	Not Required	Bracket, Terminal Strip Mounting Options: Machines with Racine Proportional Valves Machines with Vickers Proportional Valves	1	
	0901402			
16	Not Used			
17	0642032	Bolt 5/8"-20NC x 4"	3	
18	3312005	Locknut 5/8"-20NC	3	
19	4740242	Flatwasher, Special	3	
20	0701427	Bolt, Metric 14mm x 100m	4	
21	4740191	Lockwasher, Metric 14mm	4	
22	0701215	Bolt, Metric 12mm x 35mm	8	
23	4832100	Lockwasher, Metric 12mm	8	
24	Not Used			
25	Not Used			
26	Not Used			
27	Not Used			
28	4761400	Lockwasher 1/4"	3	
29	3311401	Nut 1/4"-20NC	2	
30	0721006	Bolt #10-24NF x 3/4"	2	
31	4761000	Lockwasher #10	2	
32	3321001	Nut #10-24NF	2	
33	2750527	Hose 1/8" x 78"	A/R	
34	1320060	Clamp, Hose (Not Shown - Located on Adapter Plate at Rear of Engine)	1	
35	4420001	Tape, Sealant	A/R	
36	3200183	Mount, Engine (Rear)	2	
37		Cover, Terminal Strip Options:	1	
	Not Required	Machines with Racine Proportional Valves		
	1670414	Machines with Vickers Proportional Valves		
38		Tube, Air Intake Options:	1	
	4563232	Deutz F3L912 - Machines with Racine Proportional Valves		
	4843320	Deutz F3L912 - Machines with Vickers Proportional Valves		
	4843384	Deutz F4L912 - Machines with Vickers Proportional Valves		
39	4280002	Band, Neoprene	30 in.	
40	3820009	Rivet	3	
41 to 48	Not Used			
49		Decal - Wire Identification Options:	1	
	Not Required	Machines with Racine Proportional Valves		
	1700821	Machines with Vickers Proportional Valves		
50 to 51	Not Used			
52	0700617	Bolt, Metric 6mm x 45mm	1	
53	0641416	Bolt 1/4"-20NC x 2"	2	
54	4711400	Lockwasher 1/4"	5	

**SECTION 2 TURNTABLE**

# SECTION 2 TURNTABLE

**FIGURE 2-24. DEUTZ ENGINE INSTALLATION WITHOUT NOISE REDUCTION (BUILT PRIOR TO DECEMBER 1992) (CONTINUED)**

FIG & ITEM #	PART NUMBER	DESCRIPTION	QTY.	REV.
		<b>DEUTZ ENGINE INSTALLATION</b>	Ref.	
	0236374	<b>DEUTZ F3L912 ENGINE INSTALLATION - MACHINES WITH RACINE PROPORTIONAL VALVES AND SINGLE SPEED DRIVE</b>	Ref.	A
	0237288	<b>DEUTZ F3L912 ENGINE INSTALLATION - MACHINES WITH RACINE PROPORTIONAL VALVES AND TWO SPEED DRIVE</b>	Ref.	A
	0237998	<b>DEUTZ F3L912 ENGINE INSTALLATION - MACHINES WITH VICKERS PROPORTIONAL VALVES AND STANDARD ENGINE</b>	Ref.	H
	0238025	<b>DEUTZ F3L912 ENGINE INSTALLATION - MACHINES WITH VICKERS PROPORTIONAL VALVES AND CLEAN BURN ENGINE</b>	Ref.	E
	0238023	<b>DEUTZ F4L912 ENGINE INSTALLATION - MACHINES WITH VICKERS PROPORTIONAL VALVES BUILT PRIOR TO MARCH 1991 AND STANDARD ENGINE</b>	Ref.	K
	0251822	<b>DEUTZ F4L912 ENGINE INSTALLATION - MACHINES WITH VICKERS PROPORTIONAL VALVES BUILT MARCH 1991 TO DECEMBER 1992 AND STANDARD ENGINE</b>	Ref.	C
79	1320041	Clamp	10	
80		Fuel Return Line Options:	A/R	
	2720366	Hose - 1/4"	8 Ft.	
	2720271	Hose - 3/16"	10.5 Ft.	
81		Fuel Supply Line Options:	8.5 Ft.	
	2750532	Hose - 1/4" (Used 1991 to December 1992)		
	2750015	Hose - 1/4" (Used Through 1990)		
82	0641614	Bolt 3/8"-16NC X 1 3/4"	14	
83	4761600	Lockwasher 3/8"	14	
84	3311601	Nut 3/8"-16NC	12	
85	4300031	Stud 1/4"-20NC x 5/8" (Welded On Part)	5	
86	4761400	Lockwasher 1/4"	5	
87	3311401	Nut 1/4"-20NC	5	
88	1320022	Clamp	4	
89		Fitting, Barbed Options:	2	
	2220317	Machines Built With Racine Valves		
	2220063	Machines Built With Vickers Valves		
90		Supply Line Fitting Options:	1	
	2220302	Machines Built With Racine Valves		
		Machines Built With Vickers Valves		
	2220317	Fitting (Prior to January 1991)		
	2220720	Fitting (January 1991 to December 1992)		
91	4420001	Tape, Sealant	A/R	
92	2420030	Gauge, Oil Pressure (Not Shown - Located at Ground Control)	1	
93		Auxiliary Pump Assembly Options:	1	
		Machines Built With Racine Valves		
	See Note	Auxiliary Pump Assembly	1	

**SECTION 2 TURNTABLE**

# SECTION 2 TURNTABLE

**FIGURE 2-24. DEUTZ ENGINE INSTALLATION WITHOUT NOISE REDUCTION (BUILT PRIOR TO DECEMBER 1992) (CONTINUED)**

FIG & ITEM #	PART NUMBER	DESCRIPTION	QTY.	REV.
		<b>Note: 3600115 Pump is no longer available - use 3600071 Pump.</b>		
	7013755	Replacement Motor	1	
	7004412	Replacement Coupling	1	
	Not Available	Replacement Pump (Purchase 3600071 Pump Assembly)	1	
		Machines Built With Vickers Valves		
	3600052	Stone-Fenner Pump (Used Prior to Mid 1989)		
	7000483	Replacement Motor (Includes Coupling)	1	
	7004412	Replacement Coupling	1	
	7004416	Replacement Pump	1	
	2900164	Pump Seal Kit	1	
	3600071	Haldex/Barnes Pump (Used Mid 1989 to December 1992)		
	7004248	Replacement Motor Only	1	
	7004436	Replacement Motor with Bracket	1	
	7012576	Replacement Mounting Bracket Only	1	
	7004249	Replacement Coupling	1	
	7004247	Replacement Pump	1	
	Not Available	Pump Seal Kit	1	
94	1060045	Cable, Battery (Aux. Relay to Start Relay)	1	
95	1060149	Cable, Battery (Aux. Relay to Aux. Pump and Start Relay to Starter)	2	
96	2220001	Fitting, Swivel (Not Shown - Located at Ground Control with Item 92)	1	
97	2200261	Fitting, Coupling (Not Shown - Located at Ground Control)	1	
98		Return Line Fitting Options:	1	
	2220302	Machines Built With Racine Valves		
		Machines Built With Vickers Valves		
	2220317	Fitting (Prior to January 1991)		
	2180536	Fitting (January 1991 to December 1992)		
99		Clamp Options:	1	
	Not Required	Machines Built With Racine Valves		
	1320059	Machines Built With Vickers Valves		
100		Clamp, Insulated Options:	3	
	Not Required	Machines Built With Racine Valves		
	1320040	Machines Built With Vickers Valves		
101		Fitting Options (Not Shown - Located at Ground Control with Item 92):	1	
	Not Required	Machines Built With Racine Valves		
	2220124	Machines Built With Vickers Valves		
	0236850	<b>ELECTRICAL PANEL ASSEMBLY (MACHINES BUILT PRIOR TO JULY 1986)</b>	Ref.	E
201	3740059	Relay	1	
202	3530425	Plate, Mounting	1	
203	3740002	Relay	2	
204	3740030	Relay, Adlo	1	

**SECTION 2 TURNTABLE**



# SECTION 2 TURNTABLE

**FIGURE 2-24. DEUTZ ENGINE INSTALLATION WITHOUT NOISE REDUCTION (BUILT PRIOR TO DECEMBER 1992) (CONTINUED)**

FIG & ITEM #	PART NUMBER	DESCRIPTION	QTY.	REV.
205	0641006	Bolt #10-24NC x 3/4"	6	
206	4761000	Lockwasher #10	6	
207	3311001	Nut #10-24NC	6	
208	4751000	Flatwasher #10	6	
209	0060021	Module Actuator	1	
210	0641406	Bolt 1/4"-20NC x 3/4"	2	
211	4761400	Lockwasher 1/4"	2	
212	3300220	Nut, Special	6	
213	3311001	Nut #10-24NC	3	
214	3310801	Nut #8-32NC	3	
	0237627	<b>ELECTRICAL PANEL ASSEMBLY (MACHINES BUILT JULY 1986 TO DECEMBER 1992)</b>	Ref.	F
251	3740059	Relay	1	
252	3321001	Nut #10-32NF	3	
253	3310801	Nut #8-32NC	1	
254	3530425	Plate, Mounting	1	
255		Relay Options:	1	
	3740030	Relay, Adlo (Used Prior to April 1991)		
	3740080	Relay, Sealed (Used April 1991 to December 1992)		
256	3740067	Relay	2	
257	3300220	Nut, Special	6	
258	0641405	Bolt 1/4"-20NC x 5/8"	7	
259	4761400	Lockwasher 1/4"	7	
260	3311401	Nut 1/4"-20NC	7	
261	4711400	Flatwasher 1/4" Narrow	6	
	0236388	<b>EXHAUST INSTALLATION - MACHINES BUILT PRIOR TO APRIL 1986 AND MACHINES BUILT JANUARY 1989 TO DECEMBER 1991 (SEE SECTION 10 FOR NON-STANDARD EXHAUST SYSTEMS)</b>	Ref.	I
301	3220077	Muffler	1	
302	4562664	Pipe, Exhaust	1	
303	0080117	Adaptor	1	
304	1120169	Rain Cap	1	
305	Not Used			
306	Not Used			
307	0960960	Tube	1	
308	1320019	Clamp	4	
309	Not Used			
310	Not Used			
311	Not Used			
312	Not Used			
313	Not Used			

**SECTION 2 TURNTABLE**

# SECTION 2 TURNTABLE

**FIGURE 2-24. DEUTZ ENGINE INSTALLATION WITHOUT NOISE REDUCTION (BUILT PRIOR TO DECEMBER 1992) (CONTINUED)**

FIG & ITEM #	PART NUMBER	DESCRIPTION	QTY.	REV.
314	4100025	Sleeve, Fiberglass (Not Shown)	15.6"	
315	0901387	Bracket, Hanger	2	
316	0641507	Bolt 5/16"-18NC x 7/8"	2	
317	4751500	Flatwasher 5/16"	2	
318	4761500	Lockwasher 5/16"	2	
319	3311501	Nut 5/16"-18NC	2	
320	0641607	Bolt 3/8"-16NC x 7/8"	1	
321	4751600	Flatwasher 3/8"	1	
322	4761600	Lockwasher 3/8"	1	
323	3311601	Nut 3/8"-16NC	1	
324	0181286	Angle, Support	1	
325	2551030	Gusset	1	
326	0901719	Bracket, Support	1	
327	4740252	Flatwasher, Special	3	
	0237541	<b>EXHAUST INSTALLATION - MACHINES BUILT APRIL 1986 TO JANUARY 1989 (SEE SECTION 10 FOR NON-STANDARD EXHAUST SYSTEMS)</b>	Ref.	-
341	3220043	Muffler	1	
342	1320019	Clamp, Exhaust	1	
343	1320062	Clamp, Exhaust	1	
344	4562929	Pipe, Exhaust	1	
345	4340483	Support	1	
346	4740252	Flatwasher, Special	3	
	0252050	<b>EXHAUST INSTALLATION - MACHINES BUILT DECEMBER 1991 TO DECEMBER 1992 (SEE SECTION 10 FOR NON-STANDARD EXHAUST SYSTEMS)</b>	Ref.	A
351	3220080	Muffler	1	
352	0340041	Band, Muffler	2	
353	0641406	Bolt 1/4"-20NC x 3/4"	4	
354	4751400	Flatwasher 1/4"	4	
355	4761400	Lockwasher 1/4"	4	
356	3311401	Nut 1/4"-20NC	4	
357	1320011	Clamp	4	
358	1120406	Rain-Cap	1	
359	4565267	Tube, Exhaust	2	
360	4565268	Tube, Flex Exhaust	1	
361	4565269	Adaptor, Exhaust	1	
	0236389	<b>BATTERY INSTALLATION</b>	Ref.	B
401	0400020	Battery	1	
402	3509770	Tray, Battery	1	
403	0361027	Bar	1	
404	1060147	Cable, Battery (+ Batt to Starter)	1	

SECTION 2 TURNTABLE

# SECTION 2 TURNTABLE

**FIGURE 2-24. DEUTZ ENGINE INSTALLATION WITHOUT NOISE REDUCTION (BUILT PRIOR TO DECEMBER 1992) (CONTINUED)**

FIG & ITEM #	PART NUMBER	DESCRIPTION	QTY.	REV.
405	1060046	Cable, Battery (- Batt to Ground)	1	
406	3311601	Nut 3/8"-16NC	5	
407	Not Used			
408	1320041	Clamp	3	
409	4300031	Stud (Welded on Part)	3	
410	4761400	Lockwasher 1/4"	3	
411	3311401	Nut 1/4"-20NC	3	
412	3980006	Masonite	1	
413	0630003	Rod, Tie-Down	2	
414	4300034	Stud (Welded on Part)	3	
415	4761600	Lockwasher 3/8"	3	
	0236390	<b>AIR CLEANER INSTALLATION - DEUTZ F3L912</b>	Ref.	G
	0251822	<b>AIR CLEANER INSTALLATION - DEUTZ F4L912 (SEE SECTION 10 FOR HOSTILE ENVIRONMENT NON-STANDARD COMPONENTS)</b>	Ref.	C
501		Air Cleaner/Filter Options:	1	
	2120087	Air Cleaner Assembly (Used Prior to August 1986)		
	7004214	Filter - 2120087 Air Cleaner	1	
	1340020	Air Cleaner Assembly (Used August 1986 to December 1992)	1	
	7004214	Filter - 1340020 Air Cleaner	1	
502	0080039	Elbow, Rubber	1	
503		Tube Options:	1	
	4562667	Deutz F3L912		
	4562928	Deutz F4L912		
504		Clamp Options:	2	
	1320016	Deutz F3L912		
	1320058	Deutz F4L912		
505	2720224	Hose	1	
506	4300031	Stud (Welded on Parts)	10	
507	4761400	Lockwasher 1/4"	10	
508	3311401	Nut 1/4"-20NC	10	
509	Not Used			
510	Not Used			
511	Not Used			
512	3380320	Baffle	1	
513	Not Used			
514	1120161	Bonnet	1	
515	0340002	Band	2	
516	Not Used			
517	4711400	Flatwasher 1/4"	10	
518	1320058	Clamp	2	

**SECTION 2 TURNTABLE**

# SECTION 2 TURNTABLE

**FIGURE 2-24. DEUTZ ENGINE INSTALLATION WITHOUT NOISE REDUCTION (BUILT PRIOR TO DECEMBER 1992) (CONTINUED)**

FIG & ITEM #	PART NUMBER	DESCRIPTION	QTY.	REV.
		<b>ENGINE COMPONENTS (NOT SHOWN)</b>	Ref.	
	2000066	<b>Engine Assembly - F3L912 Standard</b>	Ref.	
	2000094	<b>Engine Assembly - F3L912W Clean Burn</b>	Ref.	
	2000083	<b>Engine Assembly - F4L912 Standard</b>	Ref.	
		Gasket and Filter Kit Options:		
	7014685	Gasket and Filter Kit - Deutz F3L912 (Includes 3 different Fuel Line Washers - 12 of each, 1 Oil Plug Washer, 1 Fuel Filter, 1 Oil Filter and 1 Gasket Set)	1	
	7014686	Gasket and Filter Kit - Deutz F4L912 (Includes 3 different Fuel Line Washers - 12 of each, 1 Oil Plug Washer, 1 Fuel Filter, 1 Oil Filter and 1 Gasket Set)	1	
	Use 7029274	Filter, Fuel (was p/n 7000649)	1	
	Use 7029276	Filter, Engine Oil (was p/n 7000648)	1	
	Use 7020410	Alternator (Bosch) (was p/n 7000663)	1	
	7000872	Alternator (Delco-Remy)	1	
	70002234	Strap, Alternator Adjustment	1	
	7020413	Starter (was p/n 7000661)	1	
	7020420	Starter (Remanufactured)	1	
	7000697	Belt, Blower	1	
	7000698	Belt, Alternator	1	
		Manifold, Exhaust Options:	1	
	7000700	Engine F3L912 - 2000066 & 2000094	1	
	70001927	Engine F4L912 - 2000083		
	7000699	Gasket, Doughnut (Engine F3L912 - 2000066 & 2000094)	1	
	7016310	Lever, Throttle (Engine F3L912 - 2000066 & 2000094)	1	
	7016309	Washer, Copper Sealing	1	
	Use 7019607	Switch, Solenoid (was p/n 7016341)	1	
	7016364	Pump, Fuel Lift	1	
	7020407	Gasket, Lift Pump	1	
	7020432	Lift Pump Repair Kit	1	
	7019617	Crankshaft (Engine F3L912 - 2000066 & 2000094)	1	
	7020439	Flywheel	1	
	7020208	Gear, Ring (Flywheel)	1	
	7020400	Washer (Fuel Line)	1	
	7020401	Washer	1	
	7020402	Washer (Fuel Line)	1	
	7020403	Washer (Fuel Line)	1	
	7020405	Washer (Oil Plug)	1	
	7020409	Dipstick	1	
	7020421	Nozzle, Injector	1	
	7020422	Injector	1	
	7020423	Gasket, Injector Tip	1	
	7020433	Gasket	1	
	7020465	Cap, Filler (Engine F3L912 - 2000066 & 2000094)	1	
	7026173	Switch, Broken Belt	1	

**SECTION 2 TURNTABLE**

# SECTION 2 TURNTABLE

**FIGURE 2-24. DEUTZ ENGINE INSTALLATION WITHOUT NOISE REDUCTION (BUILT PRIOR TO DECEMBER 1992) (CONTINUED)**

FIG & ITEM #	PART NUMBER	DESCRIPTION	QTY.	REV.
	7026668	Plug	2	
	7016330	Switch, Oil Pressure	1	
	70001361	Pump, Fuel Injector (Engine F4L912 - 2000083)	4	
	70001928	Gasket, Exhaust Manifold (Engine F4L912 - 2000083)	4	
	70002252	Ring, Head Fire (Engine F4L912 - 2000083)	4	
	70002253	Complete Engine Gasket Set (Engine F4L912 - 2000083)	1	
	70002254	Piston/Cylinder Kit (Engine F4L912 - 2000083)	4	
	70002258	Bolt, Cylinder Head (Engine F4L912 - 2000083)	4	
	70002259	Washer, Head Bolt (Engine F4L912 - 2000083)	4	
	7020498	Fan (Engine F4L912 - 2000083)	1	
	7026125	Flange, Exhaust (Engine F4L912 - 2000083)	1	
	7027250	Spring, Tension (Actuator) (Engine F4L912 - 2000083)	1	

**SECTION 2 TURNTABLE**

# SECTION 2 TURNTABLE

FIGURE 2-25. DEUTZ ENGINE INSTALLATION WITH NOISE REDUCTION (BUILT DECEMBER 1992 TO PRESENT)

SECTION 2 TURNTABLE

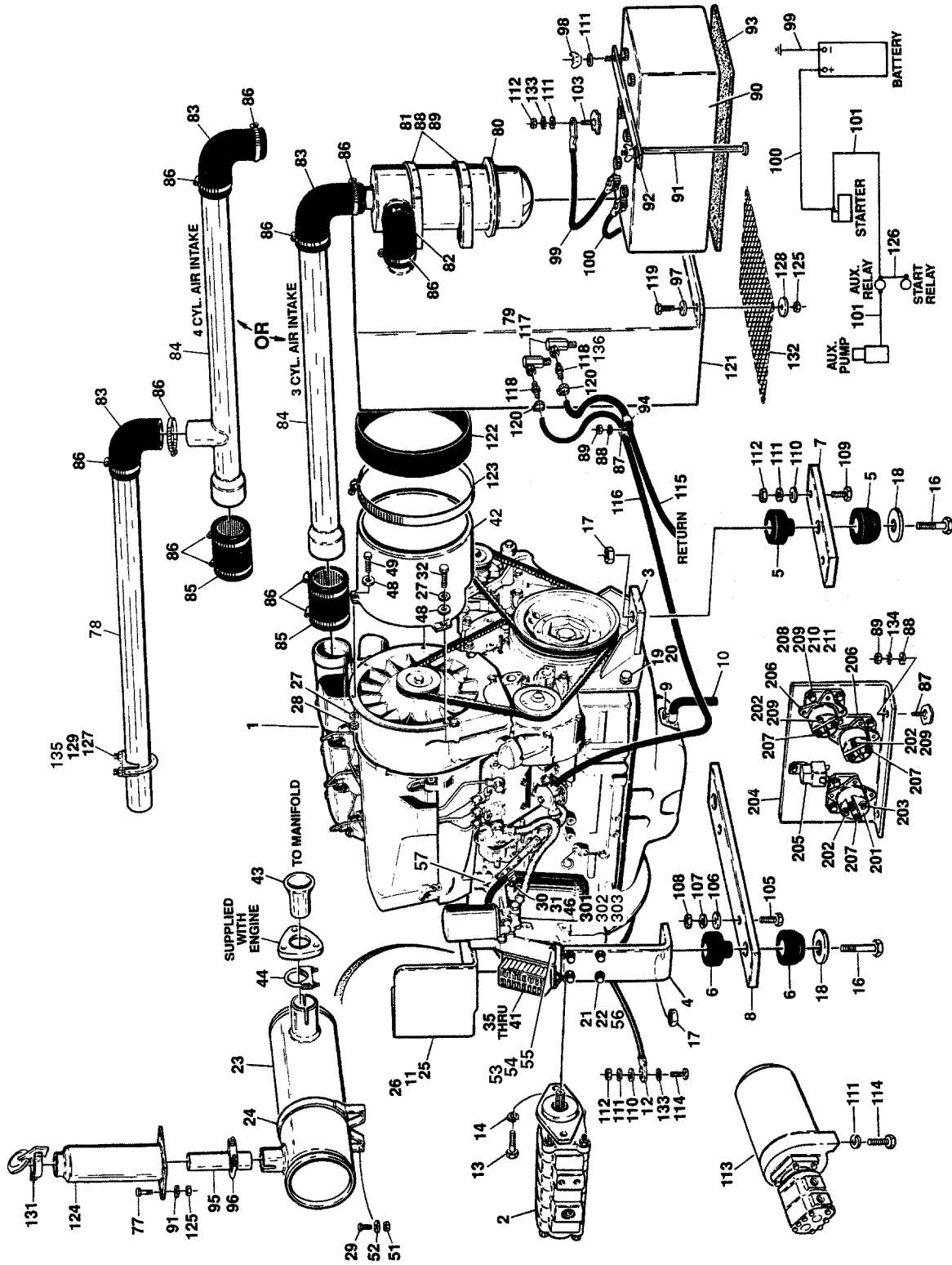

# SECTION 2 TURNTABLE

**FIGURE 2-25. DEUTZ ENGINE INSTALLATION WITH NOISE REDUCTION (BUILT DECEMBER 1992 TO PRESENT)**

FIG & ITEM #	PART NUMBER	DESCRIPTION	QTY.	REV.
		<b>DEUTZ ENGINE INSTALLATION WITH NOISE REDUCTION (BUILT DECEMBER 1992 TO PRESENT)</b>	Ref.	
	0253385	<b>DEUTZ F3L912 ENGINE ASSEMBLY - STANDARD</b>	Ref.	D
	0253387	<b>DEUTZ F3L912 ENGINE ASSEMBLY - CLEAN BURN</b>	Ref.	C
	0253327	<b>DEUTZ F4L912 ENGINE ASSEMBLY - STANDARD</b>	Ref.	C
	0254243	<b>EXHAUST INSTALLATION</b>	Ref.	A
1		Engine Options:	1	
	2000066	Engine, Deutz F3L912 - Standard		
	2000094	Engine, Deutz F3L912W - Clean Burn		
	2000083	Engine, Deutz F4L912 - Standard		
2	3600139	Pump Assembly (See Figure 2-39 for Breakdown)	1	
3	3200229	Support, Motor (Front)	1	
4	3200228	Support, Motor (Rear)	2	
5	3200133	Mount, Motor (Front)	1	
6	3200183	Mount, Motor (Rear)	2	
7	3200227	Plate, Mounting (Front)	1	
8	3200306	Plate, Mounting (Rear)	1	
9	4640742	Valve, Drain	1	
10		Hardware Options:	A/R	
	4565945	Tube (Engine, Deutz F3L912)	1	
	2720042	Hose (Engine, Deutz F4L912)	6 in.	
11	4832000	Lockwasher, Metric 10mm	2	
12		Cable, Battery (Engine to Ground) Options:	1	
	1060045	Engine, Deutz F3L912		
	1060044	Engine, Deutz F4L912		
13	0641810	Bolt 1/2"-13NC x 1 1/4"	2	
14	4761800	Lockwasher 1/2"	2	
15	Not Used			
16	0642032	Bolt 5/8"-11NC x 4"	3	
17	3312005	Locknut 5/8"-11NC	3	
18	4740242	Flatwasher, Special	3	
19	0701427	Bolt, Metric 14mm x 100mm	4	
20	4740191	Lockwasher, Metric 14mm	4	
21	0701215	Bolt, Metric 12mm x 35mm	A/R	
22	4832100	Lockwasher 12mm	8	
23	3220082	Muffler	1	
24	0340041	Band, Muffler	1	
25	0901849	Bracket, Muffler	1	
26	0701015	Bolt, Metric 10mm x 35mm	2	
27	4761400	Lockwasher 1/4"	3	
28		Locknut 1/4"-20NC Options:	A/R	
	3311405	Prior to July 1994	2	
	3311401	July 1994 to Present	2	
29	0641508	Bolt 5/16"-18NC x 1"	2	
30	2220001	Fitting, Swivel (Prior to July 1994)	1	
31	4420001	Tape, Sealing	A/R	

# SECTION 2 TURNTABLE

**FIGURE 2-25. DEUTZ ENGINE INSTALLATION WITH NOISE REDUCTION (BUILT DECEMBER 1992 TO PRESENT) (CONTINUED)**

FIG & ITEM #	PART NUMBER	DESCRIPTION	QTY.	REV.
32	0700617	Bolt, Metric 6mm x 45mm	A/R	
33	Not Used			
34	Not Used			
35	0901402	Bracket, Terminal Strip	1	
36	1320060	Clamp	1	
37	1670414	Cover, Terminal Strip	1	
38	3910812	Screw, Machine #8-32NC x 3/4"	2	
39	4770800	Starwasher #8	2	
40	3310801	Nut #8-32NC	2	
41	1700821	Decal - Wire Identification	1	
42		Air Intake Weldment Options:	1	
	4843320	Engine, Deutz F3L912		
	4843384	Engine, Deutz F4L912		
43	4565269	Adapter, Exhaust	1	
44	1320011	Clamp, Exhaust	1	
45	Not Used			
46	2750527	Hose	1	
47	Not Used			
48	4751400	Flatwasher 1/4"	A/R	
49	0641416	Bolt 1/4"-20NC x 2"	2	
50	Not Used			
51	3311505	Locknut 5/16"-18NC	2	
52	4751500	Flatwasher 5/16"	4	
53	0700810	Bolt Metric 8mm x 20mm	2	
54	4751500	Flatwasher	2	
55	4761500	Lockwasher	2	
56	0701217	Bolt Metric 12mm x 45mm	4	
57	1320222	Clamp (S/N 38256 to Present)	1	
	0253386	<b>DEUTZ ENGINE INSTALLATION - STANDARD F3L912</b>	Ref.	E
	0253388	<b>DEUTZ ENGINE INSTALLATION - CLEAN BURN F3L912</b>	Ref.	E
	0253328	<b>DEUTZ ENGINE INSTALLATION - F4L912</b>	Ref.	E
77	0641408	Bolt 1/4"-20NC x 1"	4	
78		Tube Options:	1	
	Not Required	Engine, Deutz F3L912		
	4844238	Engine, Deutz F4L912		
79	4420001	Tape, Sealant	A/R	
80	1340020	Air Cleaner Assembly (See Section 10 for Hostile Environment/Non-Standard Air Cleaners)	1	
	7004214	Filter	1	
81	0340020	Band, Mounting	2	
82	0080046	Elbow	1	
83	0080039	Elbow	A/R	
84		Tube Options:	1	
	4565877	Engine, Deutz F3L912		
	4565655	Engine, Deutz F4L912		

**SECTION 2 TURNTABLE**



# SECTION 2 TURNTABLE

**FIGURE 2-25. DEUTZ ENGINE INSTALLATION WITH NOISE REDUCTION (BUILT DECEMBER 1992 TO PRESENT) (CONTINUED)**

FIG & ITEM #	PART NUMBER	DESCRIPTION	QTY.	REV.
85	2720224	Hose	1	
86	1320058	Clamp	6	
87	4300032	Stud (Welded on Part)	8	
88	4761400	Lockwasher 1/4"	12	
89	3311401	Nut 1/4"-20NC	12	
90	0400020	Battery	1	
91	0236768	Rod, Tie-Down	2	
92	0361027	Strap, Tie-Down	1	
93	3980006	Seat, Masonite	1	
94	1320041	Clamp	6	
95	4565751	Pipe, Exhaust	1	
96	1320011	Clamp, Exhaust	1	
97	4751400	Flatwasher 1/4"	6	
98	3300029	Wingnut 3/8"-16NC	2	
99	1060046	Cable, Battery (- Batt to Ground)	1	
100	1060147	Cable, Battery (+ Batt to Start Solenoid)	1	
101	1060149	Cable, Battery (Start Solenoid to Aux Relay and Aux Relay to Aux Pump)	2	
102	2200261	Fitting, Coupling (Not Shown - Located at Ground Control with Item 130)	1	
103	4300034	Stud (Welded on Part)	1	
104	2220001	Fitting, Swivel (Not Shown - Located at Ground Control with Item 130)	1	
105	0642020	Bolt 5/8 x 2 1/2"	2	
106	4752000	Flatwasher 5/8"	2	
107	4762000	Lockwasher 5/8"	2	
108	3312001	Nut 5/8"-20NC	2	
109	0641620	Bolt 3/8"-16NC x 2 1/2"	2	
110	4751600	Flatwasher 3/8"	3	
111	4761600	Lockwasher 3/8"	8	
112	3311601	Nut 3/8"-16NC	4	
113	3600071	Auxiliary Pump Assembly - Haldex/Barnes	1	
	7004248	Motor Assembly	1	
	7004436	Motor Assembly With Mounting Bracket	1	
	7012576	Bracket Only	1	
	7004249	Coupling	1	
	7004247	Pump Assembly	1	
	Not Available	Seal Kit - 7004247 Pump	1	
114	0641614	Bolt 3/8"-16NC x 1 3/4"	3	
115	2720271	Hose, Fuel (Return)	10.5 Ft.	
116	2750532	Hose, Fuel (Supply)	8.5 Ft.	
117		Fitting, Swivel Adapter Options:	2	
	2220302	Prior to July 1994		
	2220063	July 1994 to Present		
118	2220720	Fitting, Barbed	A/R	
119	0641412	Bolt 1/4"-20NC x 1 1/2"	6	
120	1320022	Clamp, Hose	4	
121	0253194	Inlet Box Assembly	1	
122	4280002	Neoprene	2.5 Ft.	

**SECTION 2 TURNTABLE**

# SECTION 2 TURNTABLE

**FIGURE 2-25. DEUTZ ENGINE INSTALLATION WITH NOISE REDUCTION (BUILT DECEMBER 1992 TO PRESENT) (CONTINUED)**

FIG & ITEM #	PART NUMBER	DESCRIPTION	QTY.	REV.
123	1320059	Clamp	1	
124	4844235	Snorkel	1	
125	3311405	Locknut 1/4"-20NC	6	
126	1060045	Cable, Battery (Aux Relay to Start Relay)	1	
127	4751500	Flatwasher 5/16"	2	
128	4740362	Washer, Fender	6	
129	4761500	Lockwasher 5/16"	2	
130	2420030	Gauge, Oil Pressure (Not Shown - Located at Ground Control)	1	
131	1120423	Raincap	1	
132	3536008	Plate, Cover	1	
133	4791600	Starwasher 3/8"	3	
134	4791400	Starwasher 1/4"	2	
135		Clamp Options:	1	
	Not Required	Engine, Deutz F3L912		
	1320021	Engine, Deutz F4L912		
136	2180536	Fitting, Barbed (July 1994 to Present)	1	
	0237627	<b>ELECTRICAL PANEL ASSEMBLY</b>	Ref.	F
201	3740059	Relay	1	
202	3321001	Nut #10-32NF	3	
203	3310801	Nut #8-32NC	1	
204	3530425	Plate, Mounting	1	
205	3740080	Relay, Sealed	1	
206	3740067	Relay	2	
207	3300220	Nut, Special	6	
208	0641405	Bolt 1/4"-20NC x 5/8"	7	
209	4761400	Lockwasher 1/4"	7	
210	3311401	Nut 1/4"-20NC	7	
211	4711400	Flatwasher 1/4" Narrow	6	
	4931671	<b>ENGINE DISTRESS INSTALLATION (PRIOR TO SEPTEMBER 1994)</b>	Ref.	B
	0255152	<b>ENGINE DISTRESS INSTALLATION (SEPTEMBER 1994 TO PRESENT)</b>	Ref.	B
301	2180360	Fitting, Tee	1	
	4360065	Switch, Oil Pressure	1	
	4360179	Switch, Temperature (Not Shown - Located in Head Under Shroud)	1	
	0251683	<b>ENGINE RUN LIGHT INSTALLATION</b>	Ref.	B
302	4360037	Switch, Pressure	1	
	2180360	Fitting, Tee	1	

**SECTION 2 TURNTABLE**

# SECTION 2 TURNTABLE

**FIGURE 2-25. DEUTZ ENGINE INSTALLATION WITH NOISE REDUCTION (BUILT DECEMBER 1992 TO PRESENT) (CONTINUED)**

FIG & ITEM #	PART NUMBER	DESCRIPTION	QTY.	REV.
	0255274	<b>LOW OIL PRESSURE SHUTDOWN INSTALLATION</b>	Ref.	4
303	2180360	Fitting, Tee	1	
	4360065	Switch, Oil Pressure	1	
	2180749	Fitting, 45°	1	
		<b>ENGINE COMPONENTS (NOT SHOWN)</b>	Ref.	
	2000066	<b>Engine Assembly - F3L912 Standard</b>	Ref.	
	2000094	<b>Engine Assembly - F3L912W Clean Burn</b>	Ref.	
	2000083	<b>Engine Assembly - F4L912 Standard</b>	Ref.	
		Gasket and Filter Kit Options:		
	7014685	Gasket and Filter Kit - Deutz F3L912 (Includes 3 different Fuel Line Washers - 12 of each. 1 Oil Plug Washer, 1 Fuel Filter, 1 Oil Filter and 1 Gasket Set)	1	
	7014686	Gasket and Filter Kit - Deutz F4L912 (Includes 3 different Fuel Line Washers - 12 of each, 1 Oil Plug Washer, 1 Fuel Filter, 1 Oil Filter and 1 Gasket Set)	1	
	Use 7029274	Filter, Fuel (was p/n 7000649)	1	
	Use 7029276	Filter, Engine Oil (was p/n 7000648)	1	
	Use 7020410	Alternator (Bosch) (was p/n 7000663)	1	
	7000872	Alternator (Delco-Remy)	1	
	70002234	Strap, Alternator Adjustment	1	
	7020413	Starter (was p/n 7000661)	1	
	7020420	Starter (Remanufactured)	1	
	7000697	Belt, Blower	1	
	7000698	Belt, Alternator	1	
		Manifold, Exhaust Options:	1	
	7000700	Engine F3L912 - 2000066 & 2000094	1	
	70001927	Engine F4L912 - 2000083	1	
	7000699	Gasket, Doughnut (Engine F3L912 - 2000066 & 2000094)	1	
	7016310	Lever, Throttle (Engine F3L912 - 2000066 & 2000094)	1	
	7016309	Washer, Copper Sealing	1	
	Use 7019607	Switch, Solenoid (was p/n 7016341)	1	
	7016364	Pump, Fuel Lift	1	
	7020407	Gasket, Lift Pump	1	
	7020432	Lift Pump Repair Kit	1	
	7019617	Crankshaft (Engine F3L912 - 2000066 & 2000094)	1	
	7020439	Flywheel	1	
	7020208	Gear, Ring (Flywheel)	1	
	7020400	Washer (Fuel Line)	1	
7020401	Washer	1		
7020402	Washer (Fuel Line)	1		
7020403	Washer (Fuel Line)	1		
7020405	Washer (Oil Plug)	1		
7020409	Dipstick	1		

**SECTION 2 TURNTABLE**

# SECTION 2 TURNTABLE

**FIGURE 2-25. DEUTZ ENGINE INSTALLATION WITH NOISE REDUCTION (BUILT DECEMBER 1992 TO PRESENT) (CONTINUED)**

FIG & ITEM #	PART NUMBER	DESCRIPTION	QTY.	REV.
	7020421	Nozzle, Injector	1	
	7020422	Injector	1	
	7020423	Gasket, Injector Tip	1	
	7020433	Gasket	1	
	7020465	Cap, Filler (Engine F3L912 - 2000066 & 2000094)	1	
	7026173	Switch, Broken Belt	1	
	7026668	Plug	2	
	7016330	Switch, Oil Pressure	1	
	70001361	Pump, Fuel Injector (Engine F4L912 - 2000083)	4	
	70001928	Gasket, Exhaust Manifold (Engine F4L912 - 2000083)	4	
	70002252	Ring, Head Fire (Engine F4L912 - 2000083)	4	
	70002253	Complete Engine Gasket Set (Engine F4L912 - 2000083)	1	
	70002254	Piston/Cylinder Kit (Engine F4L912 - 2000083)	4	
	70002258	Bolt, Cylinder Head (Engine F4L912 - 2000083)	4	
	70002259	Washer, Head Bolt (Engine F4L912 - 2000083)	4	
	7020498	Fan (Engine F4L912 - 2000083)	1	
	7026125	Flange, Exhaust (Engine F4L912 - 2000083)	1	
	7027250	Spring, Tension (Actuator) (Engine F4L912 - 2000083)	1	

**SECTION 2 TURNTABLE**

# SECTION 2 TURNTABLE

FIGURE 2-25. DEUTZ ENGINE INSTALLATION WITH NOISE REDUCTION (BUILT DECEMBER 1992 TO PRESENT) (CONTINUED)

FIG & ITEM #	PART NUMBER	DESCRIPTION	QTY.	REV.

**S  
E  
C  
T  
I  
O  
N  
  
2  
  
T  
U  
R  
N  
T  
A  
B  
L  
E**

# SECTION 2 TURNTABLE

FIGURE 2-26. ADECO THROTTLE COMPONENTS INSTALLATION - DEUTZ ENGINE MACHINES.

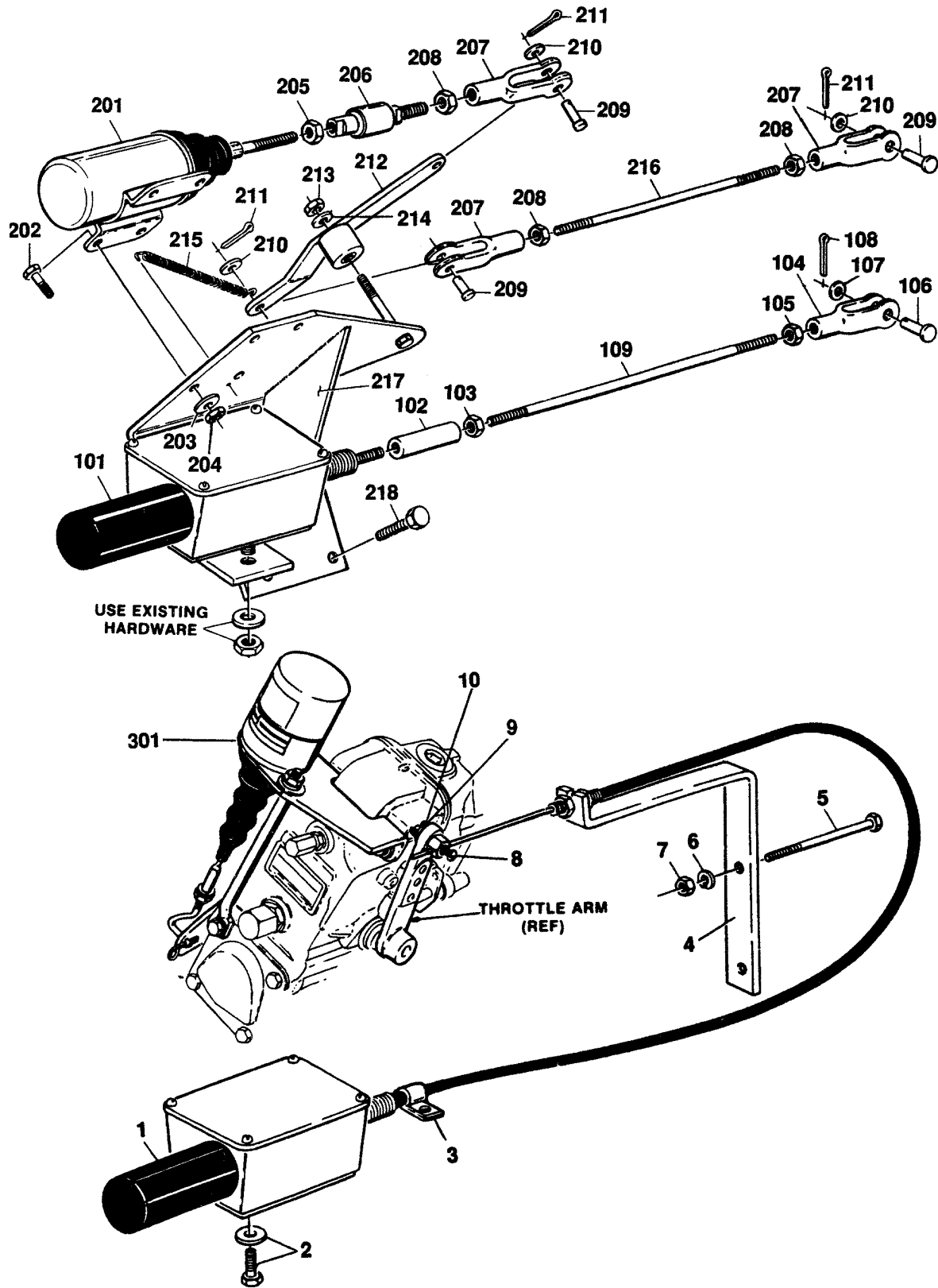

SECTION 2 TURNTABLE

# SECTION 2 TURNTABLE

**FIGURE 2-26. ADECO THROTTLE COMPONENTS INSTALLATION - DEUTZ ENGINE MACHINES.**

FIG & ITEM #	PART NUMBER	DESCRIPTION	QTY.	REV.
		<b>ADECO THROTTLE COMPONENTS INSTALLATION - DEUTZ ENGINE MACHINES</b>	Ref.	
	0237635	<b>THROTTLE ACTUATOR INSTALLATION (TURNTABLE MOUNTED ACTUATOR)</b>	Ref.	B
1	0060023	Actuator	1	
	7008804	Bellows, Rubber	1	
	7008829	Board, Circuit (Hi-Speed)	1	
	7008821	Motor, Drive	1	
	7008828	Cable, Throttle	1	
2	0641409	Bolt 1/4"-20NC x 1 1/8"	2	
	4751400	Flatwasher 1/4"	2	
3	1320041	Clamp, Cable	2	
4	0901389	Bracket, Cable	1	
5	0630400	Bolt, Metric M8-1.25 x 90MM	2	
6	4761500	Lockwasher 5/16"	2	
7	3290801	Nut, Metric M8-1.25	2	
8	4460302	Stop, Cable	1	
9	4711400	Flatwasher 1/4" Narrow	1	
10	3450203	Pin, Cotter 1/16" x 3/4"	1	
	0236953	<b>THROTTLE ACTUATOR INSTALLATION (ENGINE BRACKET MOUNTED ACTUATOR)</b>	Ref.	A
101	0060020	Actuator (Use Existing Hardware)	1	
	7008804	Bellows, Rubber	1	
	7008807	Board, Circuit (Hi-Speed)	1	
	7008821	Motor, Drive	1	
102	3300218	Connector	1	
103	3321401	Nut 1/4"-28NF	1	
104	1360112	Clevis	1	
105	3321401	Nut 1/4"-28NF	1	
106	3430406	Pin, Clevis	1	
107	4751400	Flatwasher 1/4"	1	
108	3450203	Pin, Cotter 1/16" x 3/4"	1	
109	3840819	Rod	1	
	0237630	<b>STOP-RUN SOLENOID INSTALLATION (TURNTABLE MOUNTED ACTUATOR)</b>	Ref.	-
	0236953	<b>STOP-RUN SOLENOID INSTALLATION (ENGINE BRACKET MOUNTED ACTUATOR)</b>	Ref.	A
201	3740055	Solenoid	1	
202	0641406	Bolt 1/4"-20NC x 3/4"	4	
203	4751400	Flatwasher 1/4"	4	
204	3311401	Nut 1/4"-20NC	4	
205	3321401	Nut 1/4"-28NF	1	
206	4160086	Spring, Swivel	1	

**SECTION 2 TURNTABLE**

# SECTION 2 TURNTABLE

**FIGURE 2-26. ADECO THROTTLE COMPONENTS INSTALLATION - DEUTZ ENGINE MACHINES.**

FIG & ITEM #	PART NUMBER	DESCRIPTION	QTY.	REV.
207	1360112	Clevis	3	
208	3321401	Nut 1/4"-28NF	1	
209	3430406	Pin, Clevis	1	
210	4751400	Flatwasher 1/4"	1	
211	3450203	Pin, Cotter 1/16" x 3/4"	1	
212	4842269	Arm	1	
213	3311605	Locknut 3/8" - 16NC	1	
214	4751600	Flatwasher 3/8"	1	
215	4160024	Spring	1	
216	3840818	Rod	1	
217		Mounting Bracket Options:	1	
	4842476	Bracket (Not Shown - Turntable Mounted Actuator)		
	4842270	Bracket (Engine Bracket Mounted Actuator)		
218	0630136	Bolt, Metric 8MM x 24MM	4	
		<b>STOP-RUN SOLENOID INSTALLATION (GOVERNOR MOUNTED)</b>	Ref.	-
301	0250069	Fuel Shutdown Kit (Includes Mounting Hardware)	1	

**SECTION 2 TURNTABLE**



# SECTION 2 TURNTABLE

FIGURE 2-26. ADECO THROTTLE COMPONENTS INSTALLATION - DEUTZ ENGINE MACHINES.

FIG & ITEM #	PART NUMBER	DESCRIPTION	QTY.	REV.

**S  
E  
C  
T  
I  
O  
N  
  
2  
  
T  
U  
R  
N  
T  
A  
B  
L  
E**

# SECTION 2 TURNTABLE

FIGURE 2-27. GENERATOR INSTALLATION - DEUTZ ENGINE MACHINES

SECTION 2 TURNTABLE

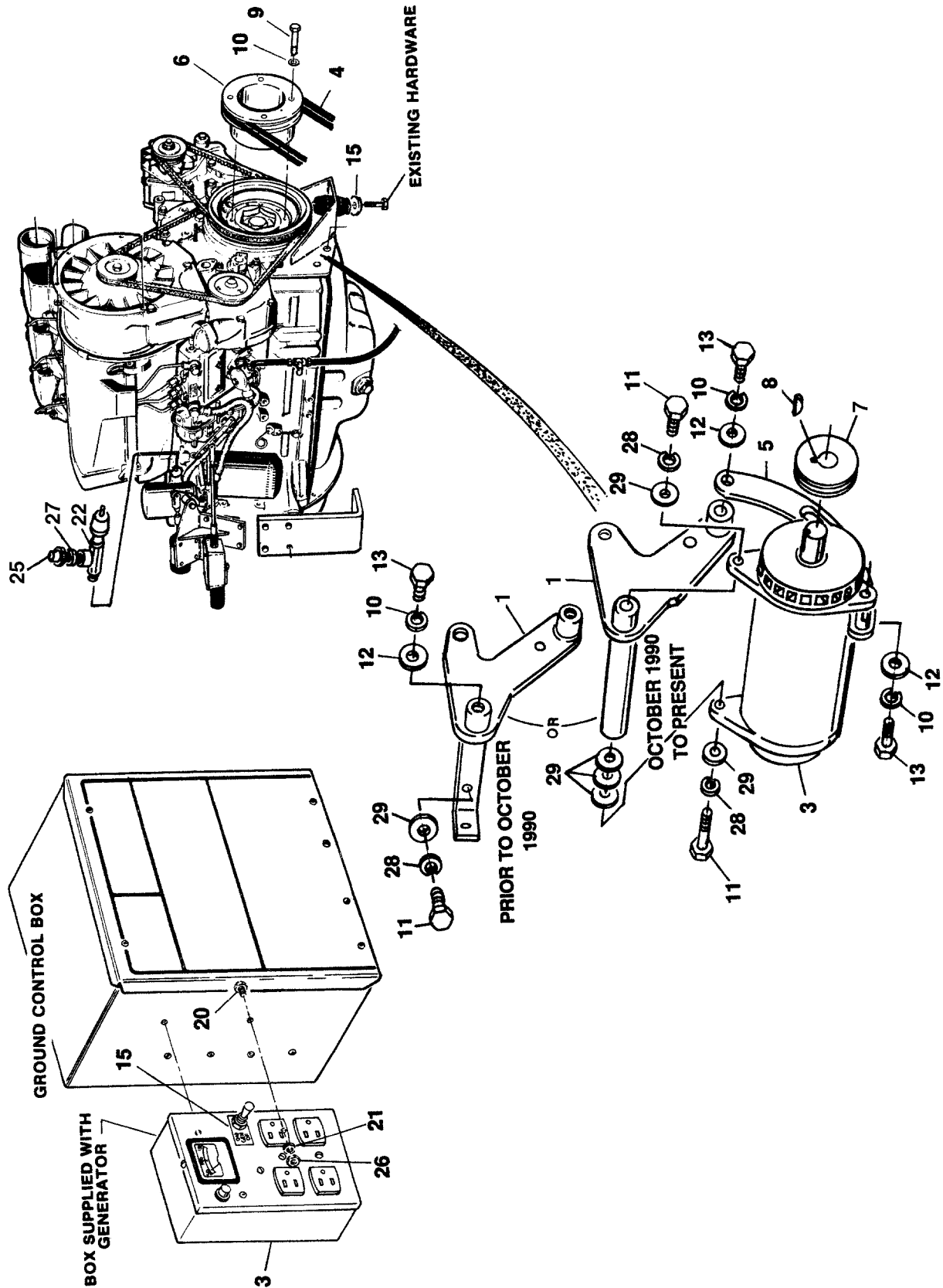

# SECTION 2 TURNTABLE

**FIGURE 2-27. GENERATOR INSTALLATION - DEUTZ ENGINE MACHINES**

FIG & ITEM #	PART NUMBER	DESCRIPTION	QTY.	REV.
		<b>GENERATOR INSTALLATION - DEUTZ ENGINE MACHINES</b> <b>Note: For machines with GFI receptacles see Section 10</b>	Ref.	
	0237132	<b>110V GENERATOR INSTALLATION - DEUTZ F3L912 ENGINE MACHINES BUILT PRIOR TO OCTOBER 1990</b>	Ref.	B
	0251422	<b>110V GENERATOR INSTALLATION - DEUTZ F3L912 ENGINE MACHINES BUILT OCTOBER 1990 TO PRESENT</b>	Ref.	H
	0251562	<b>110V GENERATOR INSTALLATION - DEUTZ F4L912 ENGINE MACHINES</b>	Ref.	F
1		Bracket, Support Options:	1	
	4842701	Prior to October 1990		
	4843133	October 1990 to Present		
2	Not Used			
3	2460011	110V Generator and Control Box Assembly	1	
	7012558	Generator Assembly	1	
	7020193	Power Cord	1	
	7026199	Armature	1	
	7020108	Brush	4	
	7020109	Holder, Brush	4	
	7012513	Cap, Brush Holder	4	
	7012514	Fan	1	
	7020110	Bell End, Front	1	
	7020111	Bell End, Rear	1	
	7020190	Bearing	2	
	7003657	Control Box Assembly	1	
		<b>Note: Replacement 110V Control Box comes with 2 std Receptacles p/n 4460190. Optional Industrial Twist Lock Receptacles p/n 4460027 must be ordered separately.</b>		
	4360542	Breaker, Circuit	1	
	2420203	Voltmeter	1	
	4460190	Receptacle	2	
	2920162	Lamp	1	
	7020191	Switch, Toggle	1	
	3520028	Plug, Hole	1	
	7020194	Breaker, Circuit	1	
4		V-Belt Options:	1	
	0480043	Used Prior to June 1992		
	0480050	Used June 1992 to Present		
5	4340511	Support, Adjustable	1	
6	3580109	Pulley		
7		Pulley Options:	1	
	3580100	Prior to October 1990		
	3580134	October 1990 to Present		
8	2860012	Key, Woodruff	1	
9	0700821	Bolt, Metric 8mm x 65mm	4	

# SECTION 2 TURNTABLE

**FIGURE 2-27. GENERATOR INSTALLATION - DEUTZ ENGINE MACHINES (CONTINUED)**

FIG & ITEM #	PART NUMBER	DESCRIPTION	QTY.	REV.
10	4761500	Lockwasher 5/16"	6	
11	0681510	Bolt 5/16" - 18NC x 1 1/4" (Grade 8)	2	
12	4751500	Flatwasher 5/16"	A/R	
13	0641507	Bolt 5/16"-18NC x 7/8"	2	
14	3251476	Decal - On/Off	1	
15	4460023	Connector, Terminal	1	
16	Not Used			
17	Not Used			
18	Not Used			
19	4920039	Wire - Red (Not Shown)	12 ft.	
20	0641406	Bolt 1/4"-20NC x 3/4"	2	
21	4761400	Lockwasher 1/4"	2	
22	Not Used	Fitting, Tee Options:	A/R	
	Not Required	Prior to October 1990	0	
	2180360	October 1990 to Present	1	
23	Not Used			
24	Not Used			
25		Switch, Pressure Options:	A/R	
	Not Required	Prior to October 1990	0	
	4360037	October 1990 to Present	1	
26	3311401	Nut 1/4" - 20NC	2	
27		Fitting, Adaptor Options:	A/R	
	Not Required	Prior to October 1990	0	
	2180730	October 1990 to Present	1	
28	4761600	Lockwasher 3/8"	2	
29	4751600	Flatwasher 3/8"	4	

**SECTION 2 TURNTABLE**

# SECTION 2 TURNTABLE

FIGURE 2-27. GENERATOR INSTALLATION - DEUTZ ENGINE MACHINES (CONTINUED)

FIG & ITEM #	PART NUMBER	DESCRIPTION	QTY.	REV.

**S  
E  
C  
T  
I  
O  
N  
  
2  
  
T  
U  
R  
N  
T  
A  
B  
L  
E**

# SECTION 2 TURNTABLE

FIGURE 2-28. FORD LSG-423 ENGINE INSTALLATIONS (PRIOR TO FEBRUARY 1995)

SECTION 2 TURNTABLE

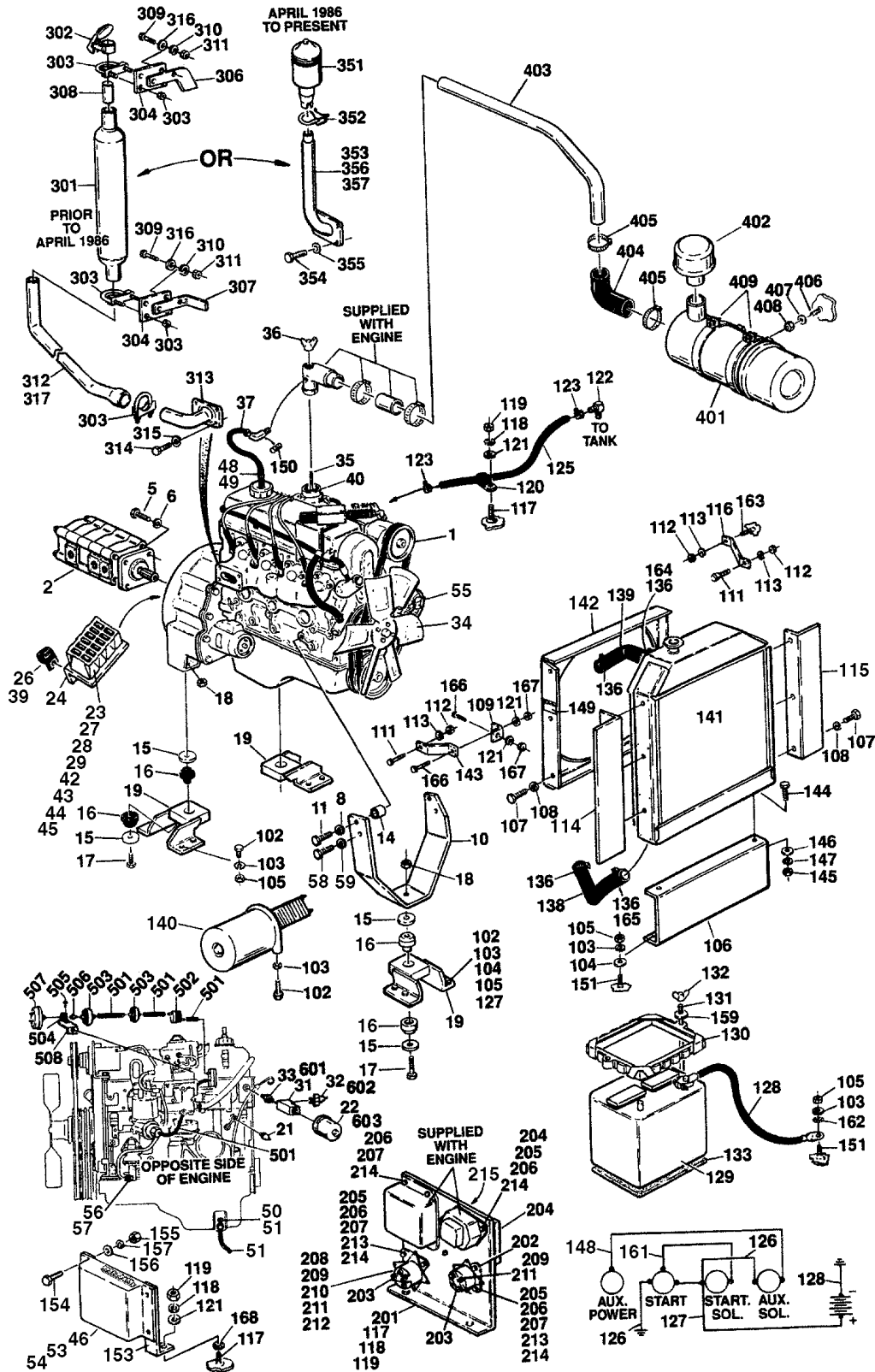

# SECTION 2 TURNTABLE

**FIGURE 2-28. FORD LSG-423 ENGINE INSTALLATIONS (PRIOR TO FEBRUARY 1995)**

FIG & ITEM #	PART NUMBER	DESCRIPTION	QTY.	REV.
		<b>Note: For Westinghouse and Piston Pump Machines Refer to Section 10.</b>		
	0236317	<b>FORD ENGINE ASSEMBLY - STANDARD MACHINES WITH RACINE PROP VALVES AND SINGLE SPEED DRIVE MOTORS</b>	Ref.	H
	0237154	<b>FORD ENGINE ASSEMBLY - STANDARD MACHINES WITH RACINE PROP VALVES AND TWO SPEED DRIVE MOTORS</b>	Ref.	B
	0236683	<b>FORD ENGINE ASSEMBLY - DUAL FUEL MACHINES WITH RACINE PROP VALVES AND SINGLE SPEED DRIVE MOTORS</b>	Ref.	G
	0237156	<b>FORD ENGINE ASSEMBLY - DUAL FUEL MACHINES WITH RACINE PROP VALVES AND TWO SPEED DRIVE MOTORS</b>	Ref.	B
	0237936	<b>FORD ENGINE ASSEMBLY - STANDARD MACHINES</b>	Ref.	I
	0237938	<b>FORD ENGINE ASSEMBLY - DUAL FUEL MACHINES WITH VICKERS PROP VALVES</b>	Ref.	K
	0254971	<b>FORD ENGINE ASSEMBLY - LP GAS ONLY MACHINES WITH VICKERS PROP VALVES</b>	Ref.	B
	0250168	<b>FORD ENIGNE ASSEMBLY - U/L DUAL FUEL MACHINES WITH VICKERS PROP VALVES</b>	Ref.	7
	0238657	<b>FORD ENGINE ASSEMBLY - U/L LP GAS ONLY MACHINES WITH VICKERS PROP VALVES</b>	Ref.	J
1	2000088	Engine, Ford LSG-423	1	
2		Pump Assembly Options:	1	
		Machines Built With Racine Valves		
	3600113	Pump with 1" - 1" - 1/2" Gear Set Single Speed Drive Motors) (See Figure 2-37 for Breakdown)		
	3600125	Pump with 1" - 3/4" - 1/2" Gear Set (2 Speed Drive Motors) (See Figure 2-37 for Breakdown)		
		All Machines Built With Vickers Valves		
	3600072	Pump with 1 Outlet in End Cover (Prior to Mid 1987) (See Figure 2-38 for Breakdown)		
	3600139	Pump with 2 Outlets in End Cover (Mid 1987 to February 1995) (See Figure 2-39 for Breakdown)		
3	Not Used			
4	Not Used			
5	0641812	Bolt 1/2"-13NC x 1 1/2"	A/R	
6	4761800	Lockwasher 1/2"	A/R	
7	Not Used			
8	4761600	Lockwasher 3/16"	4	
9	Not Used			
10	3200198	Support, Engine (Front)	1	
11	0711014	Bolt, Metric 10mm x 30mm (Grade 8)	3	
12	Not Used			
13	0701020	Bolt, Metric 10mm x 60mm (Grade 8)	1	
14	4562637	Spacer	1	
15	4740242	Flatwasher, Special	5	

**SECTION 2 TURNTABLE**

# SECTION 2 TURNTABLE

**FIGURE 2-28. FORD LSG-423 ENGINE INSTALLATIONS (PRIOR TO FEBRUARY 1995)**

FIG & ITEM #	PART NUMBER	DESCRIPTION	QTY.	REV.
16		Mount, Motor (Color Coded Green and White) Options:	3	
	3200133	Machines Built With Racine Valves		
	3200183	All Machines Built With Vickers Valves		
17	0642034	Bolt 5/8"-11NC x 4 1/4"	3	
18	3312005	Locknut 5/8"-11NC	3	
19	4842168	Support Weldment	3	
20	Not Used			
21	2420024	Sender, Temperature	1	
22	2420033	Sender, Oil Pressure	1	
23		Bracket, Terminal Strip Options:	1	
	Not Required	Machines Built With Racine Valves		
	0901401	Machines Built With Vickers Valves		
	Not Required	Machines Built With Vickers Valves - UL		
24		Decal - Terminal Strip Label Options:	1	
	Not Required	Machines Built With Racine Valves		
	1700901	Machines Built With Vickers Valves		
	Not Required	Machines Built With Vickers Valves - UL		
25		Cover, Terminal Strip Options:	1	
	Not Required	Machines Built With Racine Valves		
	1670414	Machines Built With Vickers Valves		
	Not Required	Machines Built With Vickers Valves - UL		
26		Clamp Options:	2	
	Not Required	Machines Built With Racine Valves		
	1320070	Machines Built With Vickers Valves		
	Not Required	Machines Built With Vickers Valves - UL		
27		Screw, Round Head #8-32NC x 3/4 Options:	2	
	Not Required	Machines Built With Racine Valves		
	3910812	Machines Built With Vickers Valves		
	Not Required	Machines Built With Vickers Valves - UL		
28		Starwasher #8 Options:	2	
	Not Required	Machines Built With Racine Valves		
	4770800	Machines Built With Vickers Valves		
	Not Required	Machines Built With Vickers Valves - UL		
29		Nut #8-32NC Options:	2	
	Not Required	Machines Built With Racine Valves		
	3310801	Machines Built With Vickers Valves		
	Not Required	Machines Built With Vickers Valves - UL		
30	0100020	Sealant, Pipe (Not Shown)	A/R	
31	2180360	Fitting, Tee	1	
32	4360037	Switch, Oil Pressure	1	
33	2220273	Fitting, Reducer	1	
34		Fan - 15" Options:	1	
	2060015	Machines Built With Racine Valves		
	2060016	All Machines Built With Vickers Valves		
35	4300056	Stud, Carburetor	1	
36	3300202	Wingnut 1/4"-20NC	1	
37	2720160	Hose	18 in.	
38	Not Used			

**SECTION 2 TURNTABLE**



# SECTION 2 TURNTABLE

**FIGURE 2-28. FORD LSG-423 ENGINE INSTALLATIONS (PRIOR TO FEBRUARY 1995)**

FIG & ITEM #	PART NUMBER	DESCRIPTION	QTY.	REV.
39		Flatwasher 1/2" Options:	2	
	Not Required	Machines Built With Racine Valves		
	4751800	Machines Built With Vickers Valves		
	Not Required	Machines Built With Vickers Valves - UL		
40	0080091	Adapter, Choke - Standard (See Dual Fuel Installation for Dual Fuel.LP Gas Units)	1	
41	Not Used			
42		Bolt 1/4"-20NC x 3/4" Options:	1	
	Not Required	Machines Built With Racine Valves		
	0641406	Machines Built With Vickers Valves		
	Not Required	Machines Built With Vickers Valves - UL		
43		Nut 1/4"-20NC Options:	1	
	Not Required	Machines Built With Racine Valves		
	3311401	Machines Built With Vickers Valves		
	Not Required	Machines Built With Vickers Valves - UL		
44		Flatwasher 1/4" Options:	1	
	Not Required	Machines Built With Racine Valves		
	4751400	Machines Built With Vickers Valves		
	Not Required	Machines Built With Vickers Valves - UL		
45		Lockwasher 1/4" Options:	1	
	Not Required	Machines Built With Racine Valves		
	4761400	Machines Built With Vickers Valves		
	Not Required	Machines Built With Vickers Valves - UL		
46		Controller, Precision Governor Options:	1	
	Not Required	Machines Built With Racine Valves		
	1600098	All Machines Built With Vickers Valves		
47	Not Used			
48		Tube, Plastic Options:	1 in.	
	Not Required	Machines Built With Racine Valves		
	4562516	All Machines Built With Vickers Valves		
49		Clamp Options:	1	
	Not Required	Machines Built With Racine Valves		
	1320022	Machines Built With Vickers Valves		
50		Valve Oil Drain Options:	1	
	Not Required	Machines Built With Racine Valves		
	4640750	All Machines Built With Vickers Valves		
51		Hose Options:	9 in.	
	Not Required	Machines Built With Racine Valves		
	2750532	All Machines Built With Vickers Valves		
52		Clamp Options:	A/R	
	Not Required	Machines Built With Racine Valves		
	1320032	All Machines Built With Vickers Valves		
53		Cover, Terminal Options:	1	
	Not Required	Standard		
	1670523	UL		
54		Cover, Terminal Options:	1	
	Not Required	Standard		
	1670523	UL		

# SECTION 2 TURNTABLE

**FIGURE 2-28. FORD LSG-423 ENGINE INSTALLATIONS (PRIOR TO FEBRUARY 1995)**

FIG & ITEM #	PART NUMBER	DESCRIPTION	QTY.	REV.
55	See Note 0160011	Alternator Options: Alternator (Standard) Alternator (U/L Approved)	1	
56	Not Required 2720058	Hose Options: Standard UL	9 in.	
57	Not Required 1320022	Clamp Options: Standard UL	1	
58	Not Required 0701015	Bolt Options: Standard UL	1	
59	Not Required 4751600	Flatwasher Options: Standard UL	1	
		<b>FORD ENGINE INSTALLATION (STANDARD PARTS)</b>	Ref.	
	0236318	<b>FORD ENGINE INSTALLATION - STANDARD MACHINES WITH RACINE PROP VALVES &amp; SINGLE SPEED DRIVE MOTORS</b>	Ref.	J
	0237155	<b>FORD ENGINE INSTALLATION - STANDARD MACHINES WITH RACINE PROP VALVES AND TWO SPEED DRIVE MOTORS</b>	Ref.	C
	0236684	<b>FORD ENGINE INSTALLATION - DUAL FUEL MACHINES WITH RACINE PROP VALVES &amp; SINGLE SPEED DRIVE MOTORS</b>	Ref.	G
	0237157	<b>FORD ENGINE INSTALLATION - DUAL FUEL MACHINES WITH RACINE PROP VALVES AND TWO SPEED DRIVE MOTORS</b>	Ref.	C
	0237937	<b>FORD ENGINE INSTALLATION - STANDARD MACHINES WITH VICKERS PROP VALVES BUILT PRIOR TO DECEMBER 1992</b>	Ref.	F
	0237939	<b>FORD ENGINE INSTALLATION - DUAL FUEL MACHINES WITH VICKERS PROP VALVES BUILT PRIOR TO DECEMBER 1992</b>	Ref.	F
	0250235	<b>FORD ENGINE INSTALLATION - U/L DUAL FUEL MACHINES BUILT PRIOR TO DECEMBER 1992</b>	Ref.	H
	0253599	<b>FORD ENGINE INSTALLATION - U/L DUAL FUEL MACHINES BUILT DECEMBER 1992 TO FEBRUARY 1995)</b>	Ref.	B
	0238658	<b>FORD ENGINE INSTALLATION - U/L LP GAS ONLY MACHINES BUILT PRIOR TO DECEMBER 1992</b>	Ref.	G
	0253598	<b>FORD ENGINE INSTALLATION - U/L LP GAS ONLY MACHINES BUILT DECEMBER 1992 TO FEBRUARY 1995</b>	Ref.	B
101	Not Used			
102	0641612	Bolt 3/8"-16NC x 1 1/2"	A/R	
103	4761600	Lockwasher 3/8"	A/R	
104	4751600	Flatwasher 3/8"	A/R	
105	3311601	Nut 3/8"-16NC	A/R	
106	4340343	Support, Radiator	1	

**SECTION 2 TURNTABLE**

# SECTION 2 TURNTABLE

**FIGURE 2-28. FORD LSG-423 ENGINE INSTALLATIONS (PRIOR TO FEBRUARY 1995)**

FIG & ITEM #	PART NUMBER	DESCRIPTION	QTY.	REV.
107	3941804	Screw, Self-Tapping #8-24NC x 1/2"	12	
108	4761800	Lockwasher #8	12	
109	0181234	Angle, Mounting	1	
110	Not Used			
111	0630360	Bolt, Carriage 5/16"-18NC x 1 1/4"	2	
112	3311501	Nut 5/16"-18NC	4	
113	4761500	Lockwasher 5/16"	4	
	Not Required	Machines Built With Racine Valves		
	0641406	Machines Built With Vickers Valves		
	Not Required	Machines Built With Vickers Valves - UL		
114		Baffle Options:	1	
	3380318	Machines Built With Racine Valves		
	3536244	Machines Built With Vickers Valves		
		Machines Built With Vickers Valves - UL		
	3536244	(Prior to December 1992)		
	3536549	(December 1992 to February 1995)		
115		Baffle Options:	1	
	3380319	Machines Built With Racine Valves		
	3380319	Machines Built With Vickers Valves		
		Machines Built With Vickers Valves - UL		
	3380319	(Prior to December 1992)		
	3536549	(December 1992 to February 1995)		
116	0880076	Brace	1	
117	4300032	Stud (Welded on Part)	A/R	
118	4761400	Lockwasher 1/4"	A/R	
119	3311401	Nut 1/4 - 20NC	A/R	
120	1320041	Clamp	3	
121	4751400	Flatwasher 1/4"	A/R	
122	2220317	Fitting, Barbed 90°	1	
123	1320022	Clamp	2	
124	2200051	Plug, Pipe (Not Shown Located at Fuel Tank)	1	
125	2720015	Hose, Fuel Line	75 in.	
126	1060045	Cable, Battery (Starter to Ground and Start Relay to Aux Relay)	2	
127	1060147	Cable, Battery (+ Battery to Start Relay)	1	
128	1060046	Cable, Battery (- Battery to Ground)	1	
129	0400003	Battery	1	
130	0400002	Hold-Down, Battery	1	
	2910479	Clip, Hold-Down	2	
131	0236768	Rod, Tie-Down	2	
132	3300029	Wingnut 3/8"-16NC	2	
133	3980003	Seat Battery	1	
134		Gauge, Oil Pressure Options (Not Shown - Located at Ground Control Box):	1	
	2420035	Prior to August 1994		
	2420164	August 1994 to February 1995		
135	2420019	Gauge, Temperature Options (Not Shown - Located at Ground Control Box):	1	
	2420019	Prior to August 1994		
	2420159	August 1994 to February 1995		

**SECTION 2 TURNTABLE**

# SECTION 2 TURNTABLE

**FIGURE 2-28. FORD LSG-423 ENGINE INSTALLATIONS (PRIOR TO FEBRUARY 1995)**

FIG & ITEM #	PART NUMBER	DESCRIPTION	QTY.	REV.
136	1320012	Clamp	4	
137	Not Used			
138	2720232	Hose, Radiator (Bottom)	1	
139	2720254	Hose, Radiator (Top)	1	
140		Auxiliary Pump Assembly Options:	1	
		Machines Built With Racine Valves		
	See Note	Auxiliary Pump Assembly	1	
		<b>Note: When replacing complete assembly use 3600071 pump assembly in place of original equipment 3600115 pump assembly.</b>		
		All Machines Built With Vickers Valves		
	3600071	Auxiliary Pump Assembly - Haldex/Barnes	1	
	7004436	Replacement Motor and Bracket Assembly	1	
	7004248	Replacement Motor Only	1	
	7012576	Replacement Bracket Only	1	
	7004249	Replacement Coupling	1	
	7004247	Replacement Pump	1	
	Not Available	Seal Kit - 7004247 Pump	1	
141	3620026	Radiator	1	
142		Shroud, Fan Options:	1	
	2680334	Machines Built With Racine Valves		
	2680386	All Machines Built With Vickers Valves		
143	4340525	Support, Radiator	1	
144	0630375	Bolt, Carriage 7/16" - 14NC x 1"	2	
145	3311701	Nut 1/16"-14NC x 1"	2	
146	4751700	Flatwasher 7/16"	2	
147	4761700	Lockwasher 7/16"	2	
148		Cable, Battery (Aux Relay to Aux Pump) Options:	1	
	1060129	Machines Built With Racine Valves		
	1060149	Machines Built With Vickers Valves		
		Machines Built With Vickers Valves - UL		
	1060030	Prior to August 1994		
	1060197	August 1994 to February 1995		
149	3250914	Nameplate - Caution: Fan Blade	1	
150	2200053	Fitting, Plug	1	
151	4300034	Stud (Welded on Part)	4	
152	0641614	Bolt 3/8"-16NC x 1 3/4"	A/R	
153		Bracket, Controller Options:	1	
	Not Required	Machines Built With Racine Valves		
	0901419	Machines Built With Vickers Valves		
	Not Required	Machines Built With Vickers Valves - UL		
154		Screw #10-24NCx 3/4" Options:	4	
	Not Required	Machines Built With Racine Valves		
	3911012	Machines Built With Vickers Valves		
	Not Required	Machines Built With Vickers Valves - UL		
155		Nut #10-24NC Options:	4	
	Not Required	Machines Built With Racine Valves		
	3311001	Machines Built With Vickers Valves		
	Not Required	Machines Built With Vickers Valves - UL		

SECTION 2 TURNTABLE

# SECTION 2 TURNTABLE

**FIGURE 2-28. FORD LSG-423 ENGINE INSTALLATIONS (PRIOR TO FEBRUARY 1995)**

FIG & ITEM #	PART NUMBER	DESCRIPTION	QTY.	REV.
156		Flatwasher #10 Options:	4	
	Not Required	Machines Built With Racine Valves		
	4751000	Machines Built With Vickers Valves		
	Not Required	Machines Built With Vickers Valves - UL		
157		Lockwasher #10 Options:	4	
	Not Required	Machines Built With Racine Valves		
	4761000	Machines Built With Vickers Valves		
	Not Required	Machines Built With Vickers Valves - UL		
158	Not Used			
159	4711600	Flatwasher 3/8" Narrow	2	
160		Cable, Battery (Start Relay to Starter) Options:	1	
	Not Required	Machines Built With Racine Valves		
	1060093	All Machines Built With Vickers Valves		
161		Cable, Battery (Start Relay to Starter) Options:	1	
	1060045	Machines Built With Racine Valves		
	4920961	All Machines Built With Vickers Valves		
162	4791600	Starwasher 3/8"	4	
163	4300038	Stud (Welded on Part)	1	
164	1320014	Clamp	1	
165	1320031	Clamp	1	
166	0641406	Bolt 1/4"-20NC x 3/4"	2	
167	3311405	Locknut 1/4"-20NC	2	
168	4791400	Starwasher 1/4"	2	
-----				
<b>Note: The items below are not shown, but required for U/L machines.</b>				
	0860614	Box, Contactor	1	
	3740067	Relay, Contactor	1	
	3740049	Relay	1	
	4060701	Shield, Hose	9 ft.	
	2120113	Base, Filter	1	
	2120114	Element, Filter	1	
	4640618	Valve, Fuel Shut-Off	1	
	1060092	Cable, Battery (Contactor Box to Aux Relay)	1	
	0840025	Boot, Cable	8	
	0840026	Boot, Cable	28	
	0840027	Boot, Cable	16	
	0840029	Boot, Cable	2	
	3730018	Resistor, Field (Prior to August 1994)	1	

**SECTION 2 TURNTABLE**

# SECTION 2 TURNTABLE

**FIGURE 2-28. FORD LSG-423 ENGINE INSTALLATIONS (PRIOR TO FEBRUARY 1995)**

FIG & ITEM #	PART NUMBER	DESCRIPTION	QTY.	REV.
	0236321	<b>ELECTRICAL PANEL ASSEMBLY - MACHINES WITH RACINE PROP VALVES</b>	Ref.	I
	0237859	<b>ELECTRICAL PANEL ASSEMBLY - MACHINES WITH VICKERS PROP VALVES</b>	Ref.	E
201	3509714	Plate, Mounting	1	
202	3740067	Relay, Prestolite	1	
203	3300220	Nut, Special	4	
204	3740061	Solenoid, Start Lockout	1	
205	3311401	Nut 1/4"-20NC	7	
206	0641405	Bolt 1/4"-20NC x 5/8"	10	
207	4761400	Lockwasher 1/4"	10	
208	3740059	Relay, Motorcraft	1	
209	3311001	Nut #10-24NC	2	
210	3310801	Nut #8-32NC	1	
211	4761000	Lockwasher #10	2	
212	4760800	Lockwasher #8	1	
213	4711400	Flatwasher 1/4"	4	
214	4791400	Starwasher 1/4"	9	
215		Actuator, Adeco Throttle Options:	1	
	0060021	Machines Built With Racine Valves		
	Not Required	All Machines Built With Vickers Valves		
	0236319	<b>EXHAUST INSTALLATION (USED PRIOR TO APRIL 1986) (SEE SECTION 10 FOR NON STANDARD EXHAUST SYSTEMS)</b>	Ref.	C
301	3220058	Muffler	1	
302	1120169	Cap, Rain	1	
303	1320019	Clamp	3	
304	4340470	Plate, Support	2	
305	Not Used			
306	4340420	Bracket, Support	1	
307	4340421	Bracket, Support	1	
308	0960960	Tube	1	
309	0641408	Bolt 1/4"-20NC x 1"	4	
310	4761400	Lockwasher 1/4"	4	
311	3311401	Nut 1/4"-20NC	4	
312	4562636	Pipe, Exhaust	1	
313	4841950	Adaptor, Exhaust	1	
314	0701010	Bolt, Metric 10mm x 20mm	4	
315	4761600	Lockwasher 3/8"	4	
316	4751400	Flatwasher 1/4"	4	
317	4100025	Sleeve, Fiberglass	42 in.	

**SECTION 2 TURNTABLE**

# SECTION 2 TURNTABLE

**FIGURE 2-28. FORD LSG-423 ENGINE INSTALLATIONS (PRIOR TO FEBRUARY 1995)**

FIG & ITEM #	PART NUMBER	DESCRIPTION	QTY.	REV.
	0237497	<b>EXHAUST INSTALLATION (USED APRIL 1986 TO DECEMBER 1992)</b>	Ref.	-
	0253595	<b>EXHAUST INSTALLATION (USED DECEMBER 1992 TO FEBRUARY 1995)</b> <b>Note: See Section 10 for Non-Standard Exhaust Systems</b>	Ref.	A
351		Muffler Options:	1	
	3220043	(Used April 1986 to December 1992)		
	3220052	(Used December 1992 to February 1995)		
352	1320019	Clamp	1	
353	4842226	Tube, Exhaust	1	
354	0701010	Bolt 10mm x 20mm	4	
355	4832000	Lockwasher 10mm	4	
356	4920096	Wire, Safety	2 ft.	
357	4100025	Sleeve, Fiberglass	3 ft.	
	0236398	<b>AIR CLEANER INSTALLATION - STANDARD</b>	Ref.	F
	0250720	<b>AIR CLEANER INSTALLATION - U/L MACHINES</b>		
401		Air Cleaner Assembly Options:	1	
	1340020	Air Cleaner Assembly (Standard)		
	7004214	Element, Air Cleaner	1	
	1340050	Air Cleaner Assembly (UL Machines)	1	
	7010638	Element, Air Cleaner	1	
402	1120161	Bonnet	1	
403	4842362	Tube, Air Intake	1	
404	0080039	Elbow, Rubber	1	
405	1320016	Clamp	2	
406	4300032	Stud (Welded on Part)	4	
407	4761400	Lockwasher 1/4"	4	
408	3311401	Nut 1/4"-20NC	4	
409	0340002	Bands	2	
	0237071	<b>VACUUM SWITCH INSTALLATION (SEPTEMBER 1985 TO APRIL 1986)</b>	Ref.	-
	0236988	<b>VACUUM SWITCH INSTALLATION (PRIOR TO SEPTEMBER 1985)</b>	Ref.	-
501	2720016	Hose	A/R	
502	2120112	Filter	1	
503	4360195	Switch, Vacuum Delay	2	
504	1320041	Clamp	2	
505	0641405	Bolt 1/4"-20NC x 5/8"	1	
	4761400	Lockwasher 1/4"	1	
	3311401	Nut 1/4"-20NC	1	
506	2220295	Fitting, Coupling	1	
507	4360067	Switch, Vacuum	1	
508	0901306	Bracket (4" Long)	1	
	0901333	Bracket (4 3/4" Long)	1	

**SECTION 2 TURNTABLE**

# SECTION 2 TURNTABLE

**FIGURE 2-28. FORD LSG-423 ENGINE INSTALLATIONS (PRIOR TO FEBRUARY 1995)**

FIG & ITEM #	PART NUMBER	DESCRIPTION	QTY.	REV.
	4931589	<b>ENGINE DISTRESS INSTALLATION (PRIOR TO JULY 1994)</b>	Ref.	B
	0255058	<b>ENGINE DISTRESS INSTALLATION (JULY 1994 TO FEBRUARY 1995)</b>	Ref.	A
601	2180360	Fitting, Tee	1	
602	4360182	Switch, Oil Pressure	1	
603	4360157	Switch, Water Temperature	1	
		<b>ENGINE COMPONENTS</b>	Ref.	
	2000088	<b>Engine, Ford LSG-423</b>	1	
	9982700	Carburetor (Standard Gas) Without Built-in Choke (Machines Built through 1989)	1	
	7000643	Carburetor (Standard Gas) With Built-in Choke (Machines Built 1990 to February 1995)	1	
	7000878	Rebuilt Kit - 9982700 and 7000643 Carburetor	1	
	7024321	Gasket, Carburetor (Top)	1	
	7000646	Gasket, Carburetor	1	
	7000895	Choke Assembly	1	
	1140009	Carburetor - LP Gas	1	
	7000877	Fuel Shut-Off (With Wire)	1	
	7000884	Fuel Shut-Off (With Terminal Post)	1	
	7012577	Vacuum Line Fitting	1	
	7012578	Vacuum Line Tube Assembly	1	
	7000867	Engine Harness	1	
	7010633	Fuel Pump Assembly	1	
	Use 7019932	Spark Plug (was p/n 7012595)	4	
	7019931	Wire Set, Spark Plug	1	
	7014677	Major Components Kit (Includes 1 each of Standard Gas Carburetor, Water Pump, Fuel Pump, Starter and Standard Alternator)	1	
	7010633	Pump, Fuel	1	
	Use 7012679	Starter (was p/n 7000868)	1	
	7000874	Alternator	1	
	7014678	Gasket/Electrical Kit (Includes Upper and Lower Gasket Kits, 1 each of Thermostat, Ring Gear, Belt, Coil, Ignition Module, Voltage Regulator, Starter Solenoid and Hose)	1	
	7000871	Coil	1	
	7000869	Module, Ignition	1	
	7000870	Regulator, Voltage	1	
	7014679	Tune-up Kit (Includes 4 Spark Plugs and 1 each of Oil Filter, Fuel Filter, Cap, Rotor and Ignition Wire Set)	1	
	7012595	Plug, Spark	4	
	Use 7021869	Filter, Engine Oil (Case of 12) (was p/n 7014501)	1	
	7022153	Pump, Water	1	
	7022180	Gear, Ring (Flywheel)	1	
	7023667	Fitting, Tee (Water By-Pass)	1	

**SECTION 2 TURNTABLE**



# SECTION 2 TURNTABLE

FIGURE 2-28. FORD LSG-423 ENGINE INSTALLATIONS (PRIOR TO FEBRUARY 1995)

FIG & ITEM #	PART NUMBER	DESCRIPTION	QTY.	REV.

**S  
E  
C  
T  
I  
O  
N  
  
2  
  
T  
U  
R  
N  
T  
A  
B  
L  
E**

# SECTION 2 TURNTABLE

FIGURE 2-29. ADECO THROTTLE INSTALLATIONS - FORD ENGINE MACHINES BUILT PRIOR TO MID 1987

SECTION 2 TURNTABLE

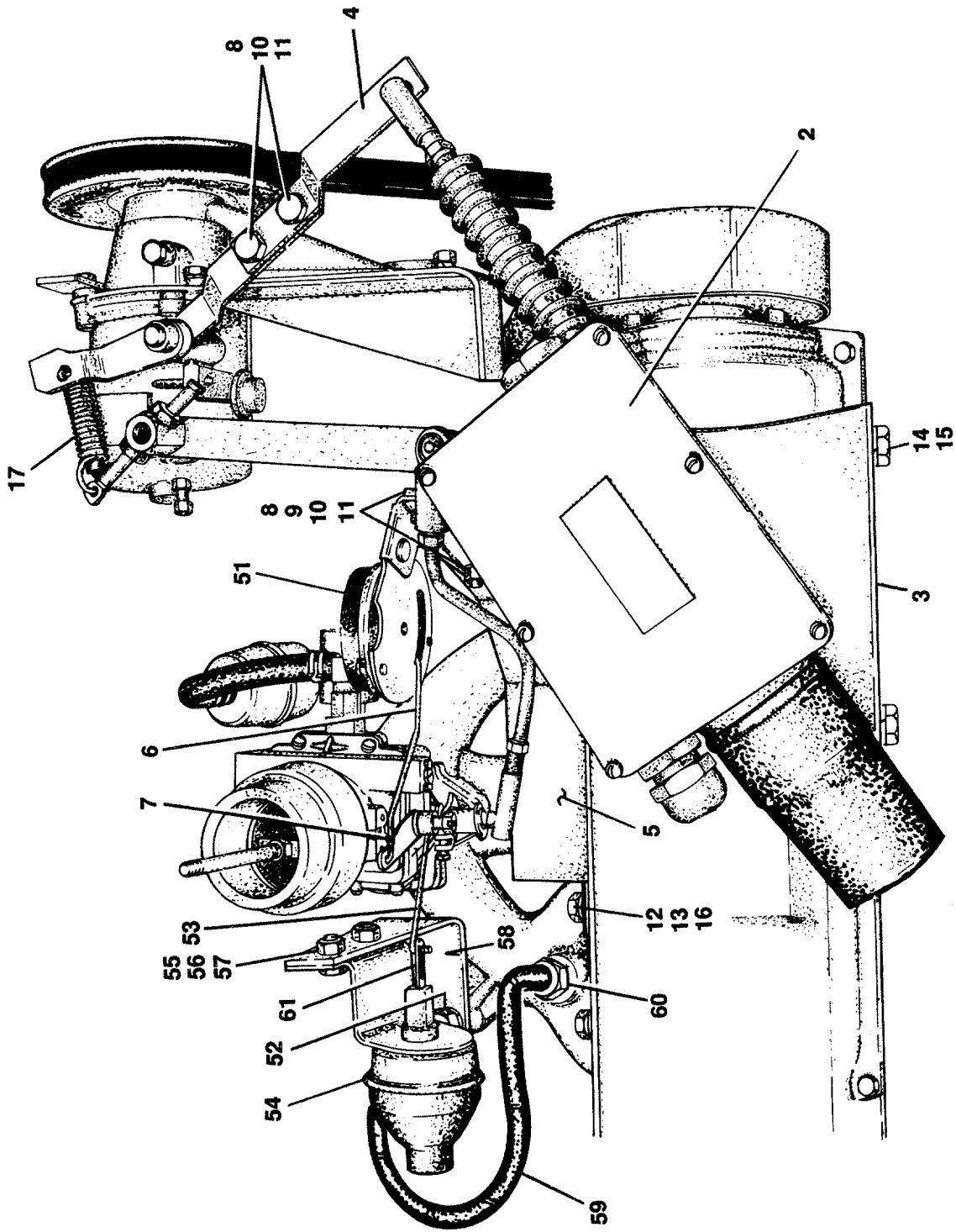

# SECTION 2 TURNTABLE

**FIGURE 2-29. ADECO THROTTLE INSTALLATIONS - FORD ENGINE MACHINES BUILT PRIOR TO MID 1987**

FIG & ITEM #	PART NUMBER	DESCRIPTION	QTY.	REV.
		<b>ADECO THROTTLE INSTALLATIONS - FORD ENGINE MACHINES BUILT PRIOR TO MID 1987</b>	Ref.	
		<b>Note: For Machines With Solenoid Controlled Throttle (Built Prior To Mid 1985) Replace With Adeco Throttle.</b>		
		<b>ADECO THROTTLE INSTALLATION (STANDARD PARTS)</b>	Ref.	
1	Not Used			
2	0060020	Actuator, Adeco	1	
	7008807	Board, Circuit	1	
	7008804	Bellows, Rubber	1	
	7008821	Motor, Drive	1	
3	4842263	Bracket, Actuator Mounting	1	
4	3010081	Link, Throttle	1	
5	0901297	Bracket, Choke Mounting	1	
6	3840821	Rod, Choke	1	
7	1380111	Clip, Rod	1	
8	0641406	Bolt 1/4"-20NC x 3/4"	4	
9	4751400	Flatwasher 1/4"	2	
10	4761400	Lockwasher 1/4"	4	
11	3311401	Nut 1/4"-20NC	4	
12	0630384	Bolt, Metric 8mm x 40mm	2	
13	4751500	Flatwasher 5/16"	3	
14	0630135	Bolt, Metric 10mm x 30mm	2	
15	4740116	Lockwasher, Metric 10mm	2	
16	4761500	Lockwasher 5/16"	2	
17	4160084	Spring	1	
	0236965	<b>ADECO THROTTLE INSTALLATION (Without Vacuum Pull-Off - Built Mid 1985 to April 1986) (Variable Parts)</b>	Ref.	-
	0237356	<b>ADECO THROTTLE INSTALLATION (WITH VACUUM PULL-OFF BUILT APRIL 1986 TO MID 1987) (VARIABLE PARTS)</b>	Ref.	B
51		Choke Kit Options:	1	
	2900097	Machines Built Mid 1985 to April 1986		
	0237715	Machines Built April 1986 to Mid 1987		
		<b>Note: Items 52-61 Machines Built April 1996 to Mid 1987 Only.</b>		
52	0700810	Bolt, Metric 8mm x 20mm	1	
53	3840855	Rod, Choke Pull-Off	1	
54	0060022	Actuator, Vacuum Choke Pull-Off	1	
55	3910808	Screw, Round Head #8-32NC x 1/2"	2	
56	4760800	Lockwasher #8	2	
57	3310801	Nut #8-32NC	2	
58	0901347	Bracket, Actuator	1	
59	2720016	Hose	12 in.	

**SECTION 2 TURNTABLE**

# SECTION 2 TURNTABLE

FIGURE 2-29. ADECO THROTTLE INSTALLATIONS - FORD ENGINE MACHINES BUILT PRIOR TO MID 1987 (CONTINUED)

FIG & ITEM #	PART NUMBER	DESCRIPTION	QTY.	REV.
60	2180666	Fitting	1	
61	1380112	Clip	1	

**S  
E  
C  
T  
I  
O  
N  
  
2  
  
T  
U  
R  
N  
T  
A  
B  
L  
E**

# SECTION 2 TURNTABLE

FIGURE 2-29. ADECO THROTTLE INSTALLATIONS - FORD ENGINE MACHINES BUILT PRIOR TO MID 1987 (CONTINUED)

FIG & ITEM #	PART NUMBER	DESCRIPTION	QTY.	REV.

**S  
E  
C  
T  
I  
O  
N  
  
2  
  
T  
U  
R  
N  
T  
A  
B  
L  
E**

# SECTION 2 TURNTABLE

FIGURE 2-30. PRECISION GOVERNOR INSTALLATION - FORD ENGINE MACHINES BUILT MID 1987 TO FEBRUARY 1995

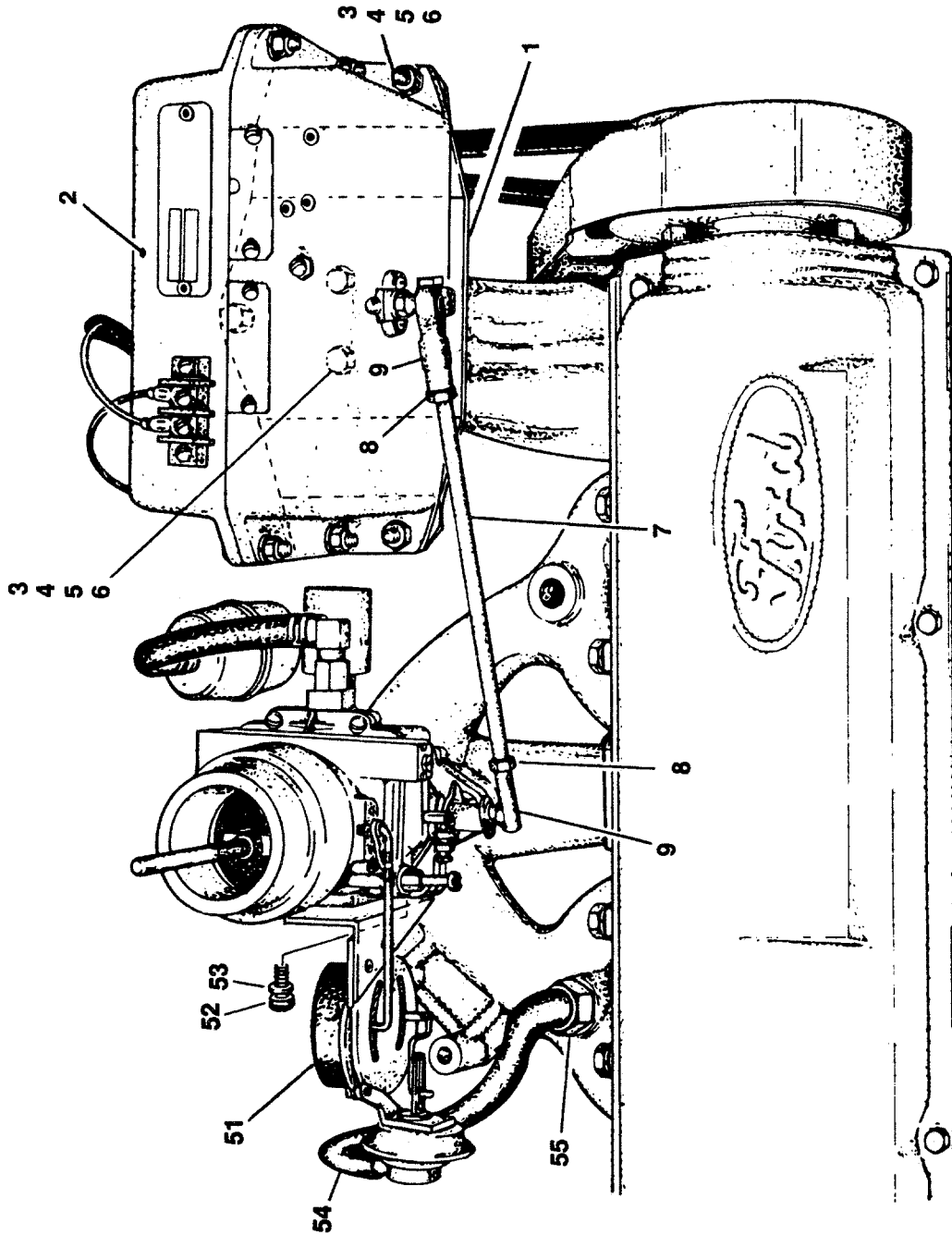

# SECTION 2 TURNTABLE

**FIGURE 2-30. PRECISION GOVERNOR INSTALLATION - FORD ENGINE MACHINES BUILT MID 1987 TO FEBRUARY 1995**

FIG & ITEM #	PART NUMBER	DESCRIPTION	QTY.	REV.
		<b>PRECISION GOVERNOR INSTALLATION - FORD ENGINE MACHINES BUILT MID 1987 TO FEBRUARY 1995</b>	Ref.	
	0238044	<b>PRECISION GOVERNOR INSTALLATION (STANDARD PARTS)</b>	Ref.	A
1	0901373	Bracket, Governor	1	
2	2500004	Governor	1	
3	0641408	Bolt 1/4"-20NC x 1"	7	
4	3311401	Nut 1/4"-20NC	7	
5	4751400	Flatwasher 1/4"	7	
6	4761400	Lockwasher 1/4"	7	
7	3840898	Rod	1	
8	3321401	Nut 1/4"-28NF	2	
9	1660157	Coupling, Ball - Joint	2	
	0238044	<b>PRECISION GOVERNOR INSTALLATION (VARIABLE PARTS REQUIRED ON 1987-1989 MODELS WITHOUT BUILT-IN CHOKE, 1990 MODELS HAVE CARBURETOR WITH BUILT-IN CHOKE)</b>	Ref.	A
51	0237568	Choke and Vacuum Pull-Off Assembly (Includes Sensor)	1	
52	3910812	Screw, Round Head #8-32NC x 3/4"	2	
53	4760800	Lockwasher #8	2	
54	2720016	Hose	1 ft.	
55	2180666	Fitting	1	

**SECTION 2 TURNTABLE**

# SECTION 2 TURNTABLE

FIGURE 2-31. GENERATOR INSTALLATION - FORD ENGINE MACHINES BUILT PRIOR TO FEBRUARY 1995

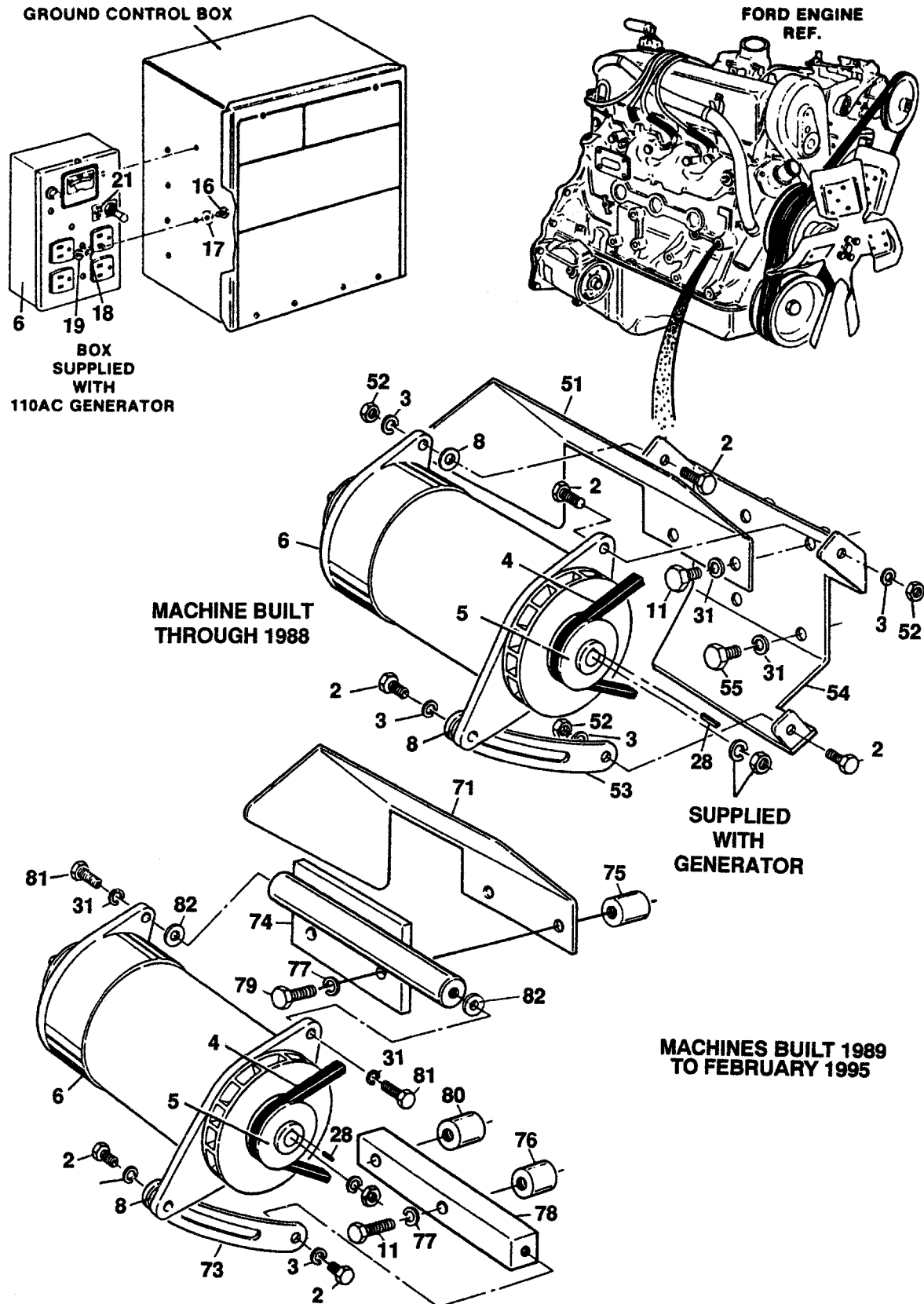

SECTION 2 TURNTABLE



# SECTION 2 TURNTABLE

**FIGURE 2-31. GENERATOR INSTALLATION - FORD ENGINE MACHINES BUILT PRIOR TO FEBRUARY 1995**

FIG & ITEM #	PART NUMBER	DESCRIPTION	QTY.	REV.
		<b>GENERATOR INSTALLATION - FORD ENGINE MACHINES BUILT PRIOR TO FEBRUARY 1995 (OPTIONAL)</b>	Ref.	
		<b>Note: U/L Machines use special items listed in Section 10 plus items listed below.</b>		
		<b>GENERATOR INSTALLATION (STANDARD PARTS)</b>	Ref.	
1	Not Used			
2	0641508	Bolt 5/16"-18NC x 1"	3	
3	4761500	Lockwasher 5/8"	4	
4		V-Belt Options:	1	
	0480037	(Prior to May 1987)		
	0480048	(May 1987 to February 1995)		
5	3580134	Pulley	1	
6	2460011	Generator and Control Box Assembly	1	
	7012558	Generator Assembly	1	
	7020193	Power Cord	1	
	7026199	Armature	1	
	7020108	Brush	4	
	7020109	Holder, Brush	4	
	7012513	Cap, Brush Holder	4	
	7012514	Fan	1	
	7020110	Bell End, Front	1	
	7020111	Bell End, Rear	1	
	7020190	Bearing	2	
	7003657	Control Box Assembly	1	
		<b>Note: Replacement 110V Control Box comes with 2 std Receptacles p/n 4460190. Optional Industrial Twist Lock Receptacles p/n 4460027 must be ordered separately.</b>		
	4360542	Breaker, Circuit	1	
	2420203	Voltmeter	1	
	4460190	Receptacle	2	
	2920162	Lamp	1	
	7020191	Switch, Toggle	1	
	3520028	Plug, Hole	1	
	7020194	Breaker, Circuit	1	
7	Not Used			
8	4751500	Flatwasher 5/16"	1	
9	Not Used			
10	Not Used			
11	0701021	Bolt, Metric 10mm x 65mm	2	
12	Not Used			
13	Not Used			
14	Not Used			
15	Not Used			
16	0721004	Screw, Machine #10-24NC x 1/2"	2	
17	4751000	Flatwasher #10	4	

**SECTION 2 TURNTABLE**

# SECTION 2 TURNTABLE

**FIGURE 2-31. GENERATOR INSTALLATION - FORD ENGINE MACHINES BUILT PRIOR TO FEBRUARY 1995 (CONTINUED)**

FIG & ITEM #	PART NUMBER	DESCRIPTION	QTY.	REV.
18	4761000	Lockwasher #10	2	
19	3311001	Nut #10-24NC	2	
20	Not Used			
21	3251476	Decal - On/Off	1	
22		Cable, Electrical -12/4 Options:	3ft/.9m	
	1060012	Prior to S/N 60653		
	1060515	S/N 60653 to February 1995		
23	4460134	Connector (Not Shown - Located at Generator)	1	
24	4460071	Connector (Not Shown - Located at Ground Control box)	1	
25	3300048	Locknut, Conduit (Not Shown - Located at Ground Control Box)	1	
26	0960238	Bushing (Not Shown - Located at Ground Control Box)	1	
27	4460023	Connector, Terminal (Not Shown - Located at Generator Control Box)	1	
28	2860012	Key	1	
29 to 30	Not Used			
31	4761600	Lockwasher 3/8"	A/R	
	0236382	<b>GENERATOR INSTALLATION (PRIOR TO MAY 1987) (VARIABLE PARTS)</b>	Ref.	C
	0236383	<b>GENERATOR INSTALLATION (MAY 1987 THROUGH 1988)</b>	Ref.	F
51	4060579	Shield, Heat	1	
52	3311501	Nut 5/16"-18NC	4	
53	4340436	Support, Adjustable	1	
54		Support Options:	1	
	4340437	(Prior to May 1987)		
	4340438	(May 1987 through 1988)		
55	0630135	Bolt, Metric 10mm x 30mm	2	
	0239244	<b>GENERATOR INSTALLATION (1989 TO MAY 1991) (VARIABLE PARTS)</b>	Ref.	I
	0251947	<b>GENERATOR INSTALLATION (MAY 1991 TO FEBRUARY 1995) (VARIABLE PARTS)</b>	Ref.	4
71	4060696	Shield, Heat	1	
72	Not Used			
73	4340565	Support, Adjustable	1	
74	4843156	Support Weldment	1	
75	4564123	Tube, Spacer	A/R	
76	4564329	Tube, Spacer	1	
77	4740116	Lockwasher, Metric 10mm	4	
78	0361704	Bar, Mounting	1	
79	0701022	Bolt, Metric 10mm x 70mm	4	
80	4564328	Tube, Spacer	1	
81	0681610	Bolt 3/8"-16NC x 1 1/4" (Grade 8)	3	
82	4751600	Flatwasher 3/8"	3	

**SECTION 2 TURNTABLE**

# SECTION 2 TURNTABLE

FIGURE 2-31. GENERATOR INSTALLATION - FORD ENGINE MACHINES BUILT PRIOR TO FEBRUARY 1995 (CONTINUED)

FIG & ITEM #	PART NUMBER	DESCRIPTION	QTY.	REV.

**S  
E  
C  
T  
I  
O  
N  
  
2  
  
T  
U  
R  
N  
T  
A  
B  
L  
E**

# SECTION 2 TURNTABLE

FIGURE 2-32. FORD LRG423/LRG425 ENGINE INSTALLATION (FEBRUARY 1995 TO PRESENT)

SECTION 2 TURNTABLE

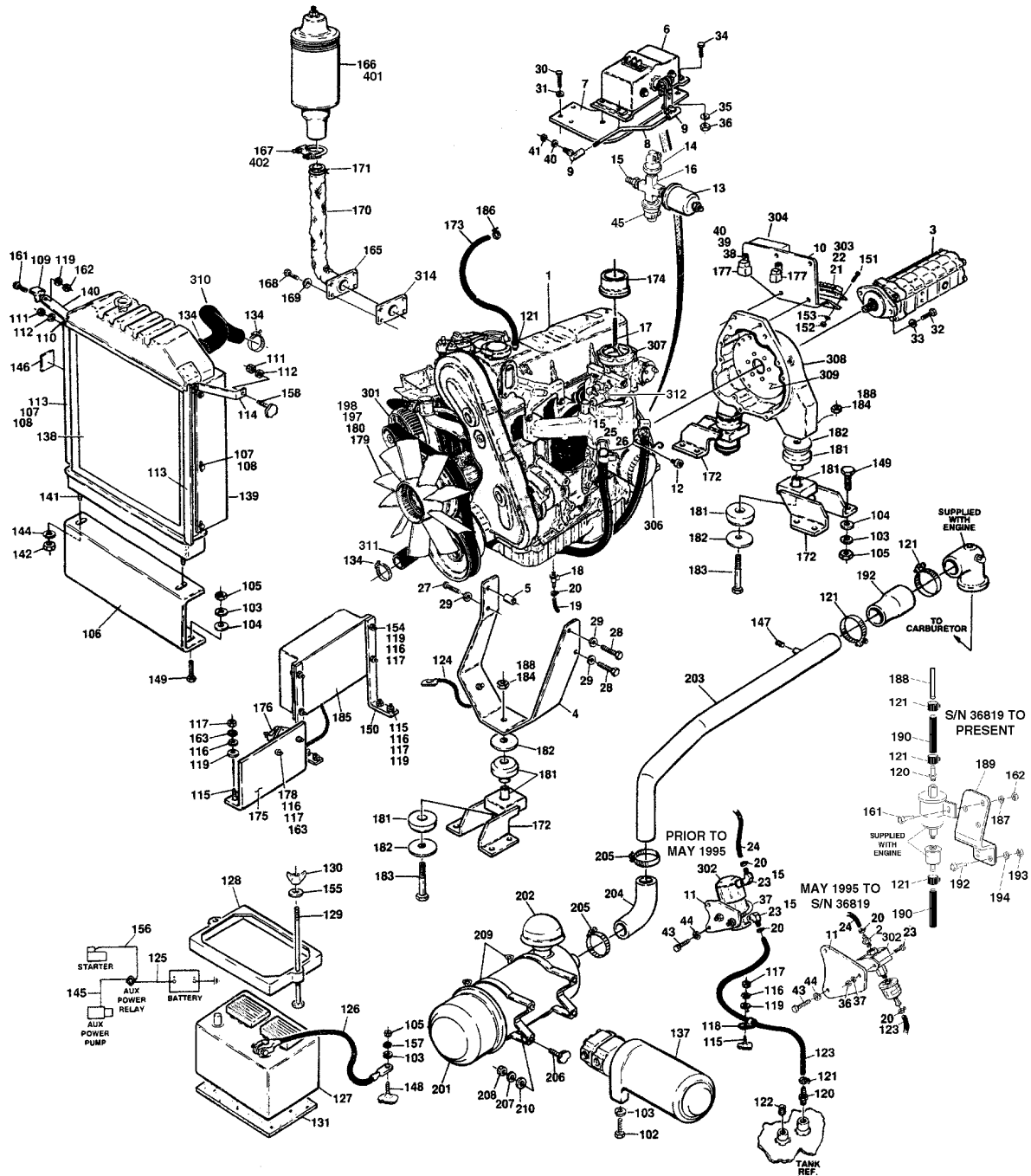

# SECTION 2 TURNTABLE

**FIGURE 2-32. FORD LRG423/LRG425 ENGINE INSTALLATION (FEBRUARY 1995 TO PRESENT)**

FIG & ITEM #	PART NUMBER	DESCRIPTION	QTY.	REV.
		<b>FORD LRG423 ENGINE INSTALLATION (FEBRUARY 1995 TO PRESENT)</b>	Ref.	
	0255120	<b>FORD ENGINE ASSEMBLY - STANDARD GAS (PRIOR TO S/N 36819)</b>	Ref.	E
	0257888	<b>FORD ENGINE ASSEMBLY - STANDARD GAS (S/N 36819 TO PRESENT)</b>	Ref.	4
	0255121	<b>FORD ENGINE ASSEMBLY - DUAL FUEL (PRIOR TO S/N 36819)</b>	Ref.	F
	0257889	<b>FORD ENGINE ASSEMBLY - DUAL FUEL (S/N 36819 TO PRESENT)</b>	Ref.	6
1		Engine Options:	1	
	2000126	Prior to S/N 36819		
	2000153	S/N 36819 to S/N 37616		
	2000157	S/N 37616 to S/N 39226		
	2000159	S/N 39226 to Present		
2	2220315	Fitting, Straight Barb	1	
3	3600139	Pump Assembly - Main (See Figure 2-39 for Breakdown)	1	
4	3200377	Mount, Engine (Front)	1	
5	4566605	Tube, Spacer	1	
6	2500005	Precision Governor Actuator	1	
7	0902088	Bracket, Governor Mounting	1	
8	3841255	Rod, Throttle	1	
9	1660157	Coupling, Ball Joint	2	
10		Bracket, Terminal Strip Mounting Options:	1	
	0902089	Prior to S/N 36819		
	0902447	S/N 36819 to Present		
11	0902087	Bracket, Fuel Pump Mounting	1	
12	2420024	Sender, Water Temperature	1	
13	2420033	Sender, Oil Pressure	1	
14	4360037	Switch, Oil Pressure	1	
15	2220273	Fitting, Reducer	A/R	
16		Fitting Options:	1	
	2180360	Prior to May 1995		
	2220994	May 1995 to Present		
17	4300056	Stud, Carburetor	1	
18		Valve, Oil Drain Options:	1	
	4640750	Prior to S/N 34331		
	4640989	S/N 34331 to Present		
19	2750532	Hose	30in/76cm	
20	1320022	Clamp, Hose	3	
21	1700901	Decal, Terminal Strip	1	
22	1670414	Cover, Terminal	1	
23		Hardware Options:	A/R	
	2220805	Fitting, 90° (Prior to May 1995)	2	
	0641404	Bolt 1/4-20NC x 1/2" (May 1995 to Present)	2	
24	2720058	Fuel Line	18in/46cm	
25	2180536	Fitting, Straight Pipe	1	

**SECTION 2 TURNTABLE**

# SECTION 2 TURNTABLE

FIGURE 2-32. FORD LRG423/LRG425 ENGINE INSTALLATION (FEBRUARY 1995 TO PRESENT)

FIG & ITEM #	PART NUMBER	DESCRIPTION	QTY.	REV.
26	2720271	Hose, Vacuum	30in/76cm	
27	0701022	Bolt 10mm x 70mm	2	
28	0701014	Bolt 10mm x 30mm	2	
29	4832000	Lockwasher 10mm	4	
30	0700810	Bolt 8mm x 20mm	3	
31	4831900	Lockwasher 8mm	3	
32	0641812	Bolt 1/2"-13NC x 1 1/2"	2	
33	4761800	Lockwasher 1/2"	2	
34	0641408	Bolt 1/4"-20NC x 1"	4	
35	4761400	Lockwasher 1/4" (Prior to May 1995)	4	
36		Nut Options:	A/R	
	3311401	Nut 1/4"-20NC (Prior to May 1995)		
	3311405	Locknut 1/4"-20NC (May 1995 to Present)		
37		Hardware Options:	A/R	
	1320019	Clamp (Prior to May 1995)	1	
	4791400	Lockwasher (May 1995 to Present)	2	
38	0721014	Bolt #10-24NC	2	
39	3311001	Nut #10-24NC	2	
40	4761000	Lockwasher #10	2	
41	3321401	Nut 1/4"-28NF	1	
42	0100020	Sealant, Pipe (Not Shown)	A/R	
43	0701015	Bolt, Metric 10mm x 35mm (Prior to S/N 36819)	1	
44	4791600	Starwasher 3/8" (Prior to S/N 36819)	2	
45	4360405	Switch, Oil Pressure (May 1995 to Present)	1	
	0255123	<b>FORD LRG423 ENGINE INSTALLATION - STANDARD GAS (Prior to S/N 36819)</b>	Ref.	6
	0257947	<b>FORD LRG425 ENGINE INSTALLATION - STANDARD GAS (S/N 36819 to Present)</b>	Ref.	5
	0255125	<b>FORD LRG423 ENGINE INSTALLATION - DUAL FUEL (Prior to S/N 36819)</b>	Ref.	C
	0257922	<b>FORD LRG425 ENGINE INSTALLATION - DUAL FUEL (S/N 36819 to Present)</b>	Ref.	6
101	Not Used			
102	0641612	Bolt 3/8"-16NC x 1 1/2"	2	
103	4751600	Flatwasher 3/8"	18	
104	4761600	Lockwasher 3/8"	14	
105	3311601	Nut 3/8"-16NC	16	
106	4340343	Support, Radiator	1	
107	3940804	Screw, Self-Tapping #10-24NC x 1/2"	12	
108	4750800	Lockwasher 3/16"	12	
109	0181234	Angle	1	
110	0630360	Bolt, Carriage 5/16"-18NC x 1 1/4"	2	
111	3311501	Nut 5/16"-18NC	3	
112	4761500	Lockwasher 5/16"	3	
113	3536549	Baffle	2	
114	0880076	Brace	1	
115	4300032	Stud (Welded on Part)	11	
116	4761400	Lockwasher 1/4"	17	

# SECTION 2 TURNTABLE

**FIGURE 2-32. FORD LRG423/LRG425 ENGINE INSTALLATION (FEBRUARY 1995 TO PRESENT)**

FIG & ITEM #	PART NUMBER	DESCRIPTION	QTY.	REV.
117	3311401	Nut 1/4"-20NC	17	
118	1320041	Clamp	3	
119	4751400	Flatwasher 1/4"	11	
120	2220315	Fitting, Barbed	A/R	
121	1320022	Clamp 1/4"	3	
122	2200051	Plug, Pipe	1	
123	2720015	Hose, Fuel Line (Prior to S/N 36819)	A/R	
124	1060045	Cable, Battery (Engine to Ground)	1	
125	1060147	Cable, Battery (+ Battery to Aux Relay)	1	
126	1060046	Cable, Battery (- Battery to Ground)	1	
127		Battery Options:	1	
	0400003	Prior to S/N 36819		
	0400075	S/N 36819 to Present		
128		Hold-Down, Battery Options:	1	
	0400002	Prior to S/N 36819		
	0361810	S/N 36819 to Present		
129	0236768	Rod, Hold-Down	2	
130	3300029	Wingnut 3/8"-16NC	2	
131		Seat, Battery Options:	1	
	3980003	Prior to S/N 36819		
	3980007	S/N 36819 to Present		
132	2420035	Gauge, Oil Pressure (Not Shown - Located at Ground Controls)	1	
133	2420019	Gauge, Temperature (Not Shown - Located at Ground Controls)	1	
134	1320012	Clamp	4	
135	Not Used			
136	Not Used			
137	3600071	Auxiliary Pump Assembly - Haldex/Barnes	1	
	7004248	Motor	1	
	7004436	Motor with Bracket	1	
	7012576	Bracket	1	
	7004249	Coupling	1	
	7004247	Pump	1	
138	3620026	Radiator	1	
139	2680386	Hood, Fan Shroud	1	
140	4340525	Support, Radiator	1	
141	0630375	Bolt, Carriage 7/16"-14NC x 1"	2	
142	3311701	Nut 7/16"-14NC	2	
143	Not Used			
144	4761700	Lockwasher 7/16"	2	
145	1060149	Cable, Battery (Aux. Relay to Aux Power)	1	
146	3250914	Decal, Caution	1	
147		Fitting, Plug - 3/8" NPT Options:	1	
	2200233	Prior to S/N 36819		
	2200053	S/N 36819 to Present		
148	4300034	Stud (Welded on Part)	1	
149	0641614	Bolt 3/8"-16NC x 1 3/4"	14	
150	0901419	Bracket, Controller	2	
151	3910812	Screw, Machine #8-32NC x 3/4"	2	

**SECTION 2 TURNTABLE**

# SECTION 2 TURNTABLE

**FIGURE 2-32. FORD LRG423/LRG425 ENGINE INSTALLATION (FEBRUARY 1995 TO PRESENT)**

FIG & ITEM #	PART NUMBER	DESCRIPTION	QTY.	REV.
152	3310801	Nut #8-32	NC	
153	4770800	Starwasher #8	2	
154	0641408	Bolt 1/4"-20NC x 1"	4	
155	4711600	Flatwasher 3/8" Narrow	2	
156	1060093	Cable, Battery (Aux Relay to Starter)	1	
157	4791600	Starwasher 3/8"	4	
158	4300038	Stud (Welded on Part)	1	
159	Not Used			
160	Not Used			
161	0641406	Bolt 1/4"-20NC x 3/4"	5	
162	3311405	Locknut 1/4"-20NC	3	
163	4771400	Starwasher 1/4"	A/R	
164	0641608	Bolt 3/8"-16NC x 1"	1	
165	4842226	Tube	1	
166		Muffler Options:	1	
	3220052	Dual Fuel Machines		
	3220052	Standard Machines (Prior to June 1997)		
	3220043	Standard Machines (June 1997 to Present)		
167	1320019	Clamp	1	
168	0701010	Bolt, Metric M10 x 1.5 x 20mm	4	
169	4832000	Lockwasher, Metric M10	4	
170	4100025	Sock, Fiberglass	3ft//9m	
171	4920096	Wire, Safety	2ft./1.6m	
172	4842168	Support	3	
173	2720160	Hose 1/2"	18 in/ 46cm	
174	0080091	Adapter, Choke	1	
175	3538387	Panel, Electrical	1	
176	3740067	Relay, Auxiliary	1	
177	3740080	Relay, Bosch	2	
178	0641406	Bolt 1/4"-20NC x 3/4"	2	
179	0080210	Adaptor, Fan Spacer	1	
180	2060025	Fan, Suction	1	
181	3200183	Mount, Rubber	3	
182	4740242	Flatwasher, Special	5	
183	0642032	Bolt 5/8"-11NC x 4"	3	
184	3312005	Locknut 5/8"-11NC	3	
185	1600211	Controller, Precision Governor	1	
186	1320032	Clamp	1	
187	4791400	Lockwasher (S/N 36819 to Present)	3	
188	4567169	Tube, Fuel Line (S/N 36819 to Present)	1	
189	3570697	Plate, Fuel Mounting (S/N 36819 to Present)	1	
190	2720058	Fuel Line (S/N 36819 to Present)	6.3ft/1.92m	
191	Not Used			
192	0641507	Bolt 5/16"-18 x 7/8 (S/N 36819 to Present)	2	
193	3311505	Locknut 5/16"-18 (S/N 36819 to Present)	2	
194	4791500	Lockwasher 5/16" (S/N 36819 to Present)	2	
195	0100011	Loctite #242 (Not Shown)	A/R	
196	0100020	Sealant, Thread (Not Shown)	A/R	
197	0630400	Bolt, Metric 8mm x 1.25 x 90mm	4	

**SECTION 2 TURNTABLE**



# SECTION 2 TURNTABLE

**FIGURE 2-32. FORD LRG423/LRG425 ENGINE INSTALLATION (FEBRUARY 1995 TO PRESENT)**

FIG & ITEM #	PART NUMBER	DESCRIPTION	QTY.	REV.
198	4831900	Lockwasher 8mm	4	
199	4562516	Tube, Hose	1 in/2.5cm	
	0255541	<b>AIR CLEANER INSTALLATION</b>	Ref.	-
201	1340020	Air Cleaner Assembly	1	
	7004214	Element, Air Cleaner	1	
202	1120161	Cap	1	
203	4844996	Tube	1	
204	0080039	Elbow, Rubber	1	
205	1320016	Clamp	2	
206	4300032	Stud (Welded on Part)	4	
207	4761400	Lockwasher 1/4"	4	
208	3311401	Nut 1/4"-20NC	4	
209	0340002	Band, Mounting	2	
210	4751400	Flatwasher 1/4"	4	
	0255058	<b>ENGINE DISTRESS INSTALLATION (NOT SHOWN)</b>	Ref.	B
	2180360	Fitting, Tee	1	
	4360182	Switch, Oil Pressure	1	
	4360157	Switch, Water Temperature	1	
		<b>ENGINE COMPONENTS</b>	Ref.	
	2000126	<b>Ford LRG-423 Engine (Prior to S/N 36819)</b>	Ref.	
		<b>Ford LRG-425 Engine</b>	Ref.	
	2000153	<b>S/N 36819 to S/N 37616</b>	Ref.	
	2000157	<b>S/N 37616 to S/N 39226</b>	Ref.	
	2000159	<b>S/N 39226 to Present</b>	Ref.	
301		Alternator Options:	1	
	7012680	LRG-423 Engine		
	7019977	LRG-425 Engine		
	7019997	Regulator (LRG-425 Engine)	1	
		Belt, Alternator Options	1	
	7019921	LRG-423 Engine		
	Use 7027402	LRG-425 Engine (was p/n 7019979)		
	7019929	Pulley, Idler (LRG-423 Engine)	1	
	7019978	Tensioner, Belt (LRG-425 Engine)	1	
302		Fuel Pump - Electric (Facet) Options:	1	
	7016600	Used on Engine - 2000126, 2000153 & 2000157		
	7019983	Used on Engines - 2000159		
		Filter, Fuel (Used with Facet Pump) Options:	1	
	7016601	Used on Engine - 2000126 & 2000157		
	Use 7027972	Used on Engines - 2000153 & 2000159 (was p/n 7019928)		
303		Harness, Engine Options:	1	
	7012682	LRG-423 Engine		
	7019980	LRG-425 Engine		

**SECTION 2 TURNTABLE**

# SECTION 2 TURNTABLE

**FIGURE 2-32. FORD LRG423/LRG425 ENGINE INSTALLATION (FEBRUARY 1995 TO PRESENT)**

FIG & ITEM #	PART NUMBER	DESCRIPTION	QTY.	REV.
304	7012681	Module, Ignition Options: LRG-423 Engine	1	
	Use 7023687	LRG-425 Engine (was 7019961)		
305	7012679	Starter (Far Side - Not Shown)	1	
	7025145	Solenoid, Starter (Far Side - Not Shown)		
306	Use 7021869	Filter, Engine Oil (Case of 12) (was p/n 7014501)	1	
307		Carburetor Options:	1	
	7012690	Used on 2000126 Engines		
	Use 7019988	Used on Engine - 2000153 & 2000157 (was p/n 7019974)		
	7019988	Used on Engines - 2000159		
	7024321	Gasket, Carburetor (Top)		
	7000646	Gasket, Carburetor		
	7019933	Carburetor Repair Kit		
	7016605	Choke, Automatic		
		Float Assembly Options:		
	7023471	LRG-423 Engine		
	7027292	LRG-425 Engine		
		Base, Carburetor Options:		
	Not Available	LRG-423 Engine		
	7025122	LRG-425 Engine		
	308	7020120		
7019976		Flywheel	1	
7022180		Gear, Ring	1	
309	Use 1660249	Coupling (was p/n 7012656)	1	
310	Use 7019926	Hose, Radiator (Top) (was p/n 7016375)	1	
311	Use 7019927	Hose, Radiator (Bottom) (was p/n 7016376)	1	
312		Pump, Water Options (Not Shown):	1	
	Use 7022153	LRG-423 Engine (was p/n 7016638)		
	7019985	LRG-425 Engine		
		Tube Inlet, Water Pump Options (Not Shown):		
	Not Available	LRG-423 Engine		
	7019982	LRG-425 Engine		
		Thermostat (Not Shown) (LRG-425 Engine)		
	Not Available	LRG-423 Engine		
	7022156	LRG-425 Engine		
		Gasket, Water Outlet Connection Options (Not Shown):		
Not Available	LRG-423 Engine			
7025134	LRG-425 Engine			
313		Gasket, Exhaust manifold to head Options (Not Shown):	1	
	7022143	LRG-423 Engine		
	Not Available	LRG-425 Engine		
314	70002307	Gasket Options (Exhaust manifold to Pipe):	1	
315	4360157	Switch, Water Temperature (Not Shown)	1	
316	7000884	Fuel Shut-Off (With Terminal Post) (Not Shown)	1	
317	Use 7025126	Manifold, Intake (was p/n 7019923) (Not Shown)	1	
318	7019924	Manifold, Exhaust (Not Shown)	1	
319	7019925	Valve, PCV (Not Shown)	1	

**SECTION 2 TURNTABLE**

# SECTION 2 TURNTABLE

**FIGURE 2-32. FORD LRG423/LRG425 ENGINE INSTALLATION (FEBRUARY 1995 TO PRESENT)**

FIG & ITEM #	PART NUMBER	DESCRIPTION	QTY.	REV.
320	7019930	Coil, Ignition (Not Shown)	1	
	7019932	Spark Plug (Not Shown)	4	
	7019931	Wire Set, Spark Plug (Not Shown)	1	
321	7022178	Sensor, Crank (Not Shown)	1	
322	7019981	Indicator, Oil Level (Not Shown) (Used on Engines - 2000159)	1	
323	2420109	Dipstick (Not Shown) (Used on Engines - 2000159)	1	
324	4564281	Tube, Dipstick (Not Shown) (Used on Engines - 2000159)	1	
325	70000163	Needle-Spring Load Fuel Valve (Not Shown) (Used on Engines - 2000159)	1	
326	7022139	Sensor, MAP (Not Shown) (Used on Engines - 2000159)	1	
	0258793	<b>EXHAUST STANDARD</b>	Ref.	
	0258794	<b>EXHAUST PURIFIER (OPTIONAL)</b>	Ref.	
401		Muffler Options:	1	
	3220043	Standard		
	3220115	Purifier		
402	1320019	Clamp, Muffler	1	

SECTION 2 TURNTABLE

# SECTION 2 TURNTABLE

FIGURE 2-33. 110 VOLT GENERATOR INSTALLATION - FORD MACHINES BUILT FEBRUARY 1995 TO PRESENT (OPTIONAL)

SECTION 2 TURNTABLE

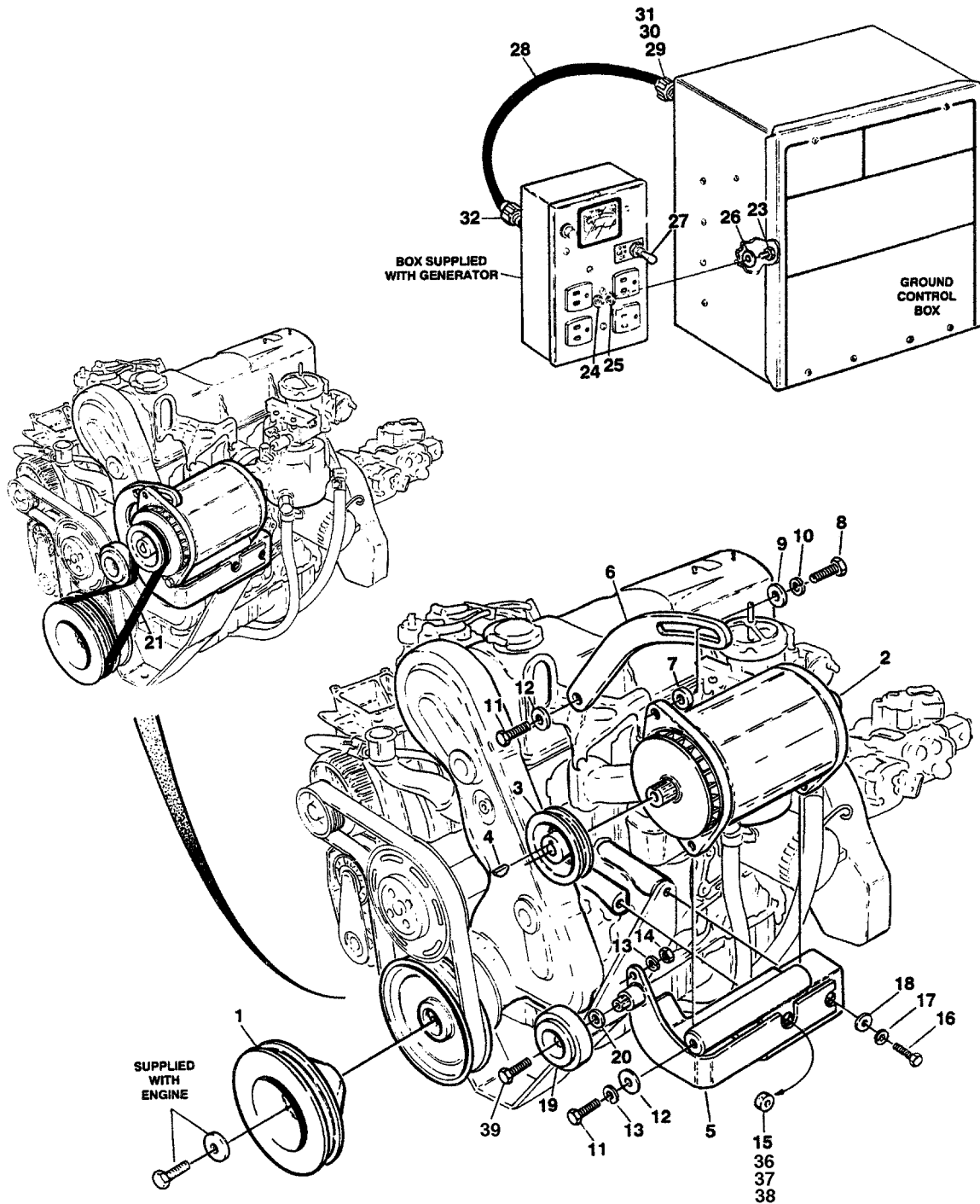

# SECTION 2 TURNTABLE

**FIGURE 2-33. 110 VOLT GENERATOR INSTALLATION - FORD MACHINES BUILT FEBRUARY 1995 TO PRESENT (OPTIONAL)**

FIG & ITEM #	PART NUMBER	DESCRIPTION	QTY.	REV.
	0255227	<b>GENERATOR INSTALLATION</b>	Ref.	8
1	3580250	Pulley, Crankshaft	1	
2	2460011	Generator and Control Box Assembly	1	
	7012558	Generator Assembly	1	
	7020193	Power Cord	1	
	7026199	Armature	1	
	7020108	Brush	4	
	7020109	Holder, Brush	4	
	7012513	Cap, Brush Holder	4	
	7012514	Fan	1	
	7020110	Bell End, Front	1	
	7020111	Bell End, Rear	1	
	7020190	Bearing	2	
	7003657	Control Box Assembly	1	
		<b>Note: Replacement 110V Control Box comes with 2 std Receptacles p/n 4460190. Optional Industrial Twist Lock Receptacles p/n 4460027 must be ordered separately.</b>		
	4360542	Breaker, Circuit	1	
	2420203	Voltmeter	1	
	4460190	Receptacle	2	
	2920162	Lamp	1	
	7020191	Switch, Toggle	1	
	3520028	Plug, Hole	1	
	7020194	Breaker, Circuit	1	
3	3580134	Pulley	1	
4	2860012	Key, Woodruff	1	
5	0902104	Bracket, Generator Mounting	1	
6	0200530	Arm, Adjusting	1	
7	4564417	Tube, Spacer	1	
8	0641508	Bolt 5/16"-18NC x 1"	1	
9	4751500	Flatwasher 5/16"	1	
10	4761500	Lockwasher 5/16"	1	
11	0641612	Bolt 3/8"-16NC x 1 1/2"	3	
12	4751600	Flatwasher 3/8"	3	
13	4761600	Lockwasher 3/8"	3	
14	3311601	Nut 3/8"-16NC	1	
15	4566650	Tube, Spacer	1	
16	0701015	Bolt 10mm - 1.5 x 35mm	2	
17	4812000	Flatwasher 10mm	2	
18	4832000	Lockwasher	2	
19	3580239	Pulley, Idler	1	
20	4740275	Spacer	1	
21	0480090	Belt, Generator	1	
22	0100011	Loctite (Not Shown)	A/R	
23	0721004	Bolt #10-24NC x 1/2"	2	
24	3311001	Nut #10-24NC	2	
25	4751000	Flatwasher #10	6	

**SECTION 2 TURNTABLE**

# SECTION 2 TURNTABLE

**FIGURE 2-33. 110 VOLT GENERATOR INSTALLATION - FORD MACHINES BUILT FEBRUARY 1995 TO PRESENT (OPTIONAL) (CONTINUED)**

**SECTION 2 TURNTABLE**

FIG & ITEM #	PART NUMBER	DESCRIPTION	QTY.	REV.
26	4761000	Lockwasher #10	2	
27	3251476	Nameplate, Generator	1	
28		Cable, Electrical -12/4 Options:	3ft/.9m	
	1060012	Prior to S/N 60653		
	1060515	S/N 60653 to Present		
29	4460071	Connector, Strain Relief	1	
30	0960238	Bushing	1	
31	3300048	Nut, Conduit	1	
32	4460023	Connector, Strain Relief	1	
33 to 35	Not Used			
36	4070585	Shim (.010)	A/R	
37	4070586	Shim (.005)	A/R	
38	4070587	Shim (.002)	A/R	
39	0641608	Bolt 3/8"-16NC x 1"	1	

# SECTION 2 TURNTABLE

FIGURE 2-33. 110 VOLT GENERATOR INSTALLATION - FORD MACHINES BUILT FEBRUARY 1995 TO PRESENT (OPTIONAL) (CONTINUED)

FIG & ITEM #	PART NUMBER	DESCRIPTION	QTY.	REV.

**S  
E  
C  
T  
I  
O  
N  
  
2  
  
T  
U  
R  
N  
T  
A  
B  
L  
E**

# SECTION 2 TURNTABLE

FIGURE 2-34. DUAL FUEL INSTALLATION - FORD ENGINE MACHINES

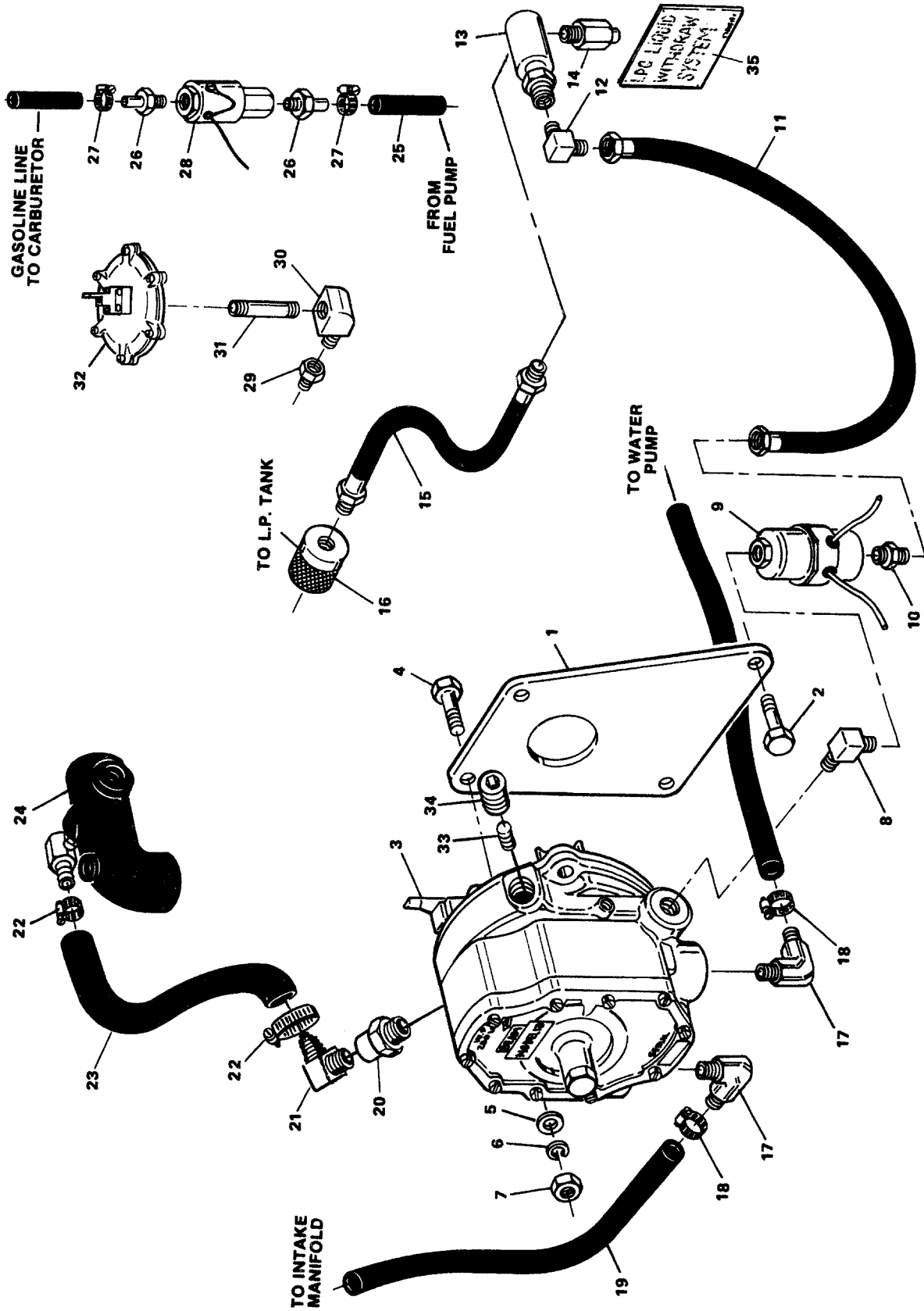

SECTION 2 TURNTABLE



# SECTION 2 TURNTABLE

**FIGURE 2-34. DUAL FUEL INSTALLATION - FORD ENGINE MACHINES**

FIG & ITEM #	PART NUMBER	DESCRIPTION	QTY.	REV.
		<b>DUAL FUEL INSTALLATION - FORD ENGINE MACHINES</b>	Ref.	
1		Plate, Regulator Mounting Options:	1	
	3530210	(Prior to March 1995)		
	0902089	(Not Shown - March 1995 to S/N 36819)		
	0902447	(Not Shown - S/N 36819 to Present)		
2	0641711	Bolt 7/16"-14NC x 1 3/8"	2	
3	4700005	Regulator	1	
	7017515	Repair Kit	1	
4	0641416	Bolt 1/4"-20NC x 2"	2	
5	4751400	Flatwasher 1/4" (Prior to S/N 36819)	2	
6	4761400	Lockwasher 1/4" (Prior to S/N 36819)	2	
7		Nut Options:	2	
	3311401	Nut 1/4"-20NC (Prior to S/N 36819)		
	3311405	Locknut 1/4"-20NC (S/N 36819 to Present)		
8	2220082	Fitting, 90°	1	
9	2120077	L.P. Filter Lock	1	
10	2180418	Fitting	1	
11	2720149	Hose	1	
12	2180504	Fitting, 90°	1	
13	2180388	Filter	1	
14	2180389	Valve, Relief	1	
15	2720117	Hose	1	
16	2180387	Fitting, L.P. Tank	1	
17		Fitting, 90° Options:	2	
	2220313	Prior to March 1995		
	2220675	March 1995 to Present		
18	1320022	Clamp, Hose	2	
19	2750532	Hose	24 in.	
20	2220251	Fitting, Reducer	1	
21		Fitting Options:	1	
	2220675	Fitting, 90° (Prior to S/N 36819)		
	2210016	Fitting, Nipple (S/N 36819 to Present)		
22	1320030	Clamp, Hose	2	
23	2720112	Hose	24 in.	
24	0080124	Adapter, Carburetor	1	
25	2720058	Hose	9 in.	
26	2220315	Fitting, Barbed	A/R	
	2220648	Fitting, 90° (Located at Fuel Pump - March 1995 to May 1995)	1	
	2220437	Fitting, Reducer (Located at Fuel Pump - March 1995 to May 1995)	1	
27	1320022	Clamp, Hose (Prior to May 1995)	2	
28	4640391	Valve, Fuel Lock (Prior to May 1995)	1	
	1320060	Clamp, Mounting (Not Shown)	1	
29		Fitting, Reducer Options:	1	
	2220430	Prior to March 1995		
	2220273	March 1995 to Present		

**SECTION 2 TURNTABLE**

# SECTION 2 TURNTABLE

**FIGURE 2-34. DUAL FUEL INSTALLATION - FORD ENGINE MACHINES (CONTINUED)**

FIG & ITEM #	PART NUMBER	DESCRIPTION	QTY.	REV.
30	2200461	Fitting, 90° (Prior to March 1985)	1	
	2180360	Fitting, Tee (March 1995 to Present)	1	
	2720271	Hose, Vacuum (March 1995 to Present)	A/R	
	2180536	Fitting, Barbed	1	
31	2180420	Fitting, Nipple (Prior to March 1995)	1	
	2180104	Fitting, Nipple (March 1995 to Present)	1	
32	4360188	Switch, Vacuum	1	
33	2200221	Plug, 1/8"	1	
34	2200204	Plug, 3/4"	1	
35	1700818	Decal - LPG Liquid Withdraw System (Located on Hood Next to Item #14)	1	

**SECTION 2 TURNTABLE**

# SECTION 2 TURNTABLE

FIGURE 2-34. DUAL FUEL INSTALLATION - FORD ENGINE MACHINES (CONTINUED)

FIG & ITEM #	PART NUMBER	DESCRIPTION	QTY.	REV.

**S  
E  
C  
T  
I  
O  
N  
  
2  
  
T  
U  
R  
N  
T  
A  
B  
L  
E**

# SECTION 2 TURNTABLE

FIGURE 2-35. PUMP COUPLING INSTALLATIONS

SECTION 2 TURNTABLE

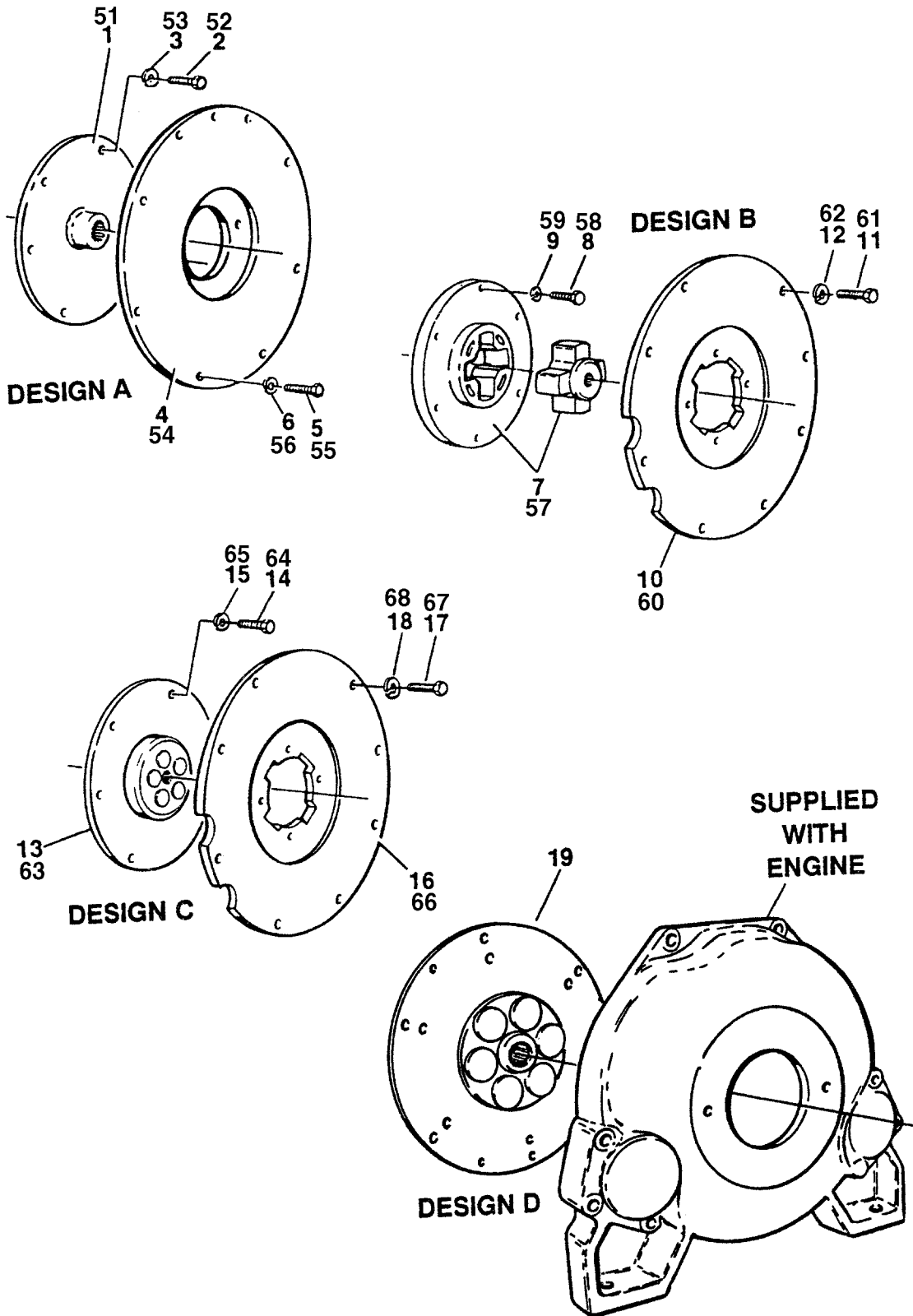

# SECTION 2 TURNTABLE

**FIGURE 2-35. PUMP COUPLING INSTALLATIONS**

FIG & ITEM #	PART NUMBER	DESCRIPTION	QTY.	REV.
		<b>PUMP COUPLING INSTALLATIONS</b>	Ref.	
		<b>PUMP COUPLING INSTALLATIONS (FORD ENGINES)</b>	Ref.	
		<b>JLG DISC INSTALLATION (DESIGN A)</b>	Ref.	
1	1760019	Disc Assembly (Machines with 4 Bolt Mount Pump)	1	
	1760106	Disc Assembly (Machines with 2 Bolt Mount Pump)	1	
2	0641606	Bolt 3/8"-16NC x 3/4"	6	
3	4761600	Lockwasher 3/8"	6	
4	0080121	Adapter, Pump (Machines with 4 Bolt Mount Pump)	1	
	0080119	Adapter, Pump (Machines with 2 Bolt Mount Pump)	1	
5	0641608	Bolt 3/8"-16NC x 1"	8	
6	4761600	Lockwasher 3/8"	8	
	0239962	<b>LOVEJOY COUPLING INSTALLATION (DESIGN B)</b>	Ref.	-
7	1660170	Coupling - Lovejoy	1	
	1660174	Hub, Coupling	1	
	1660175	Disc, Coupling	1	
8	0641610	Bolt 3/8"-16NC x 1 1/4"	6	
9	4761600	Lockwasher 3/8"	6	
10	0080163	Adapter, Pump	1	
11	0641610	Bolt 3/8"-16NC x 1 1/4"	8	
12	4761600	Lockwasher 3/8"	8	
	0250599	<b>HAYES COUPLING INSTALLATION (DESIGN C)</b>	Ref.	-
13	1660183	Coupling (Design C)	1	
14	0641607	Bolt 3/8"-16NC x 7/8"	6	
15	4761600	Lockwasher 3/8"	6	
16	0080163	Adapter, Pump Mounting (Design C)	1	
17	0641610	Bolt 3/8"-16NC x 1 1/4"	8	
18	4761600	Lockwasher 3/8"	8	
	3020021	Grease	A/R	
	1660218	<b>HAYES COUPLING INSTALLATION (DESIGN D)</b>	Ref.	-
19	7012656	Coupling (Design D)	1	
		<b>PUMP COUPLING INSTALLATIONS (DEUTZ ENGINES)</b>	Ref.	
		<b>JLG DISC INSTALLATION (DESIGN A)</b>	Ref.	
51	1760019	Disc Assembly (Use with 4 Bolt Mounted Pump)	1	
	1760106	Disc Assembly (Use with 2 Bolt Mounted Pump)	1	
52	0701010	Bolt, Metric 10mm x 20mm	6	
53	4832000	Lockwasher 10mm	6	
54	0080029	Plate, Adapter (Use with 4 Bolt Mounted Pump)	1	
	0080087	Plate, Adapter (Use with 2 Bolt Mounted Pump)	1	
55	0701014	Bolt 10mm x 30mm	12	

# SECTION 2 TURNTABLE

**FIGURE 2-35. PUMP COUPLING INSTALLATIONS (CONTINUED)**

FIG & ITEM #	PART NUMBER	DESCRIPTION	QTY.	REV.
56	4832000	Lockwasher, Metric 10mm	12	
	0239954	<b>LOVEJOY COUPLING INSTALLATION (DESIGN B)</b>	Ref.	-
57	1660170	Coupling - Lovejoy	1	
	1660174	Hub, Coupling	1	
	1660175	Disc, Coupling	1	
58	0701014	Bolt, Metric 10mm x 30mm	6	
59	4832000	Lockwasher 10mm	6	
60	0080164	Adapter, Pump	1	
61	0701014	Bolt, Metric 10mm x 30mm	12	
62	4832000	Lockwasher 10mm	12	
	0250600	<b>HAYES COUPLING INSTALLATION (DESIGN C)</b>	Ref.	-
63	1660183	Coupling (Design C)	1	
64	0701010	Bole, Metric 10mm x 20mm	6	
65	4832000	Lockwasher 10mm	6	
66	0080164	Adapter, Pump	1	
67	0701014	Bolt, Metric 10mm x 30mm	12	
68	4832000	Lockwasher 10mm	12	
<b>Note: Design D not used on Deutz Engines</b>				

**SECTION 2 TURNTABLE**

# SECTION 2 TURNTABLE

FIGURE 2-35. PUMP COUPLING INSTALLATIONS (CONTINUED)

FIG & ITEM #	PART NUMBER	DESCRIPTION	QTY.	REV.

**S  
E  
C  
T  
I  
O  
N  
  
2  
  
T  
U  
R  
N  
T  
A  
B  
L  
E**

# SECTION 2 TURNTABLE

FIGURE 2-36. WISCONSIN ENGINE INSTALLATION

SECTION 2 TURNTABLE

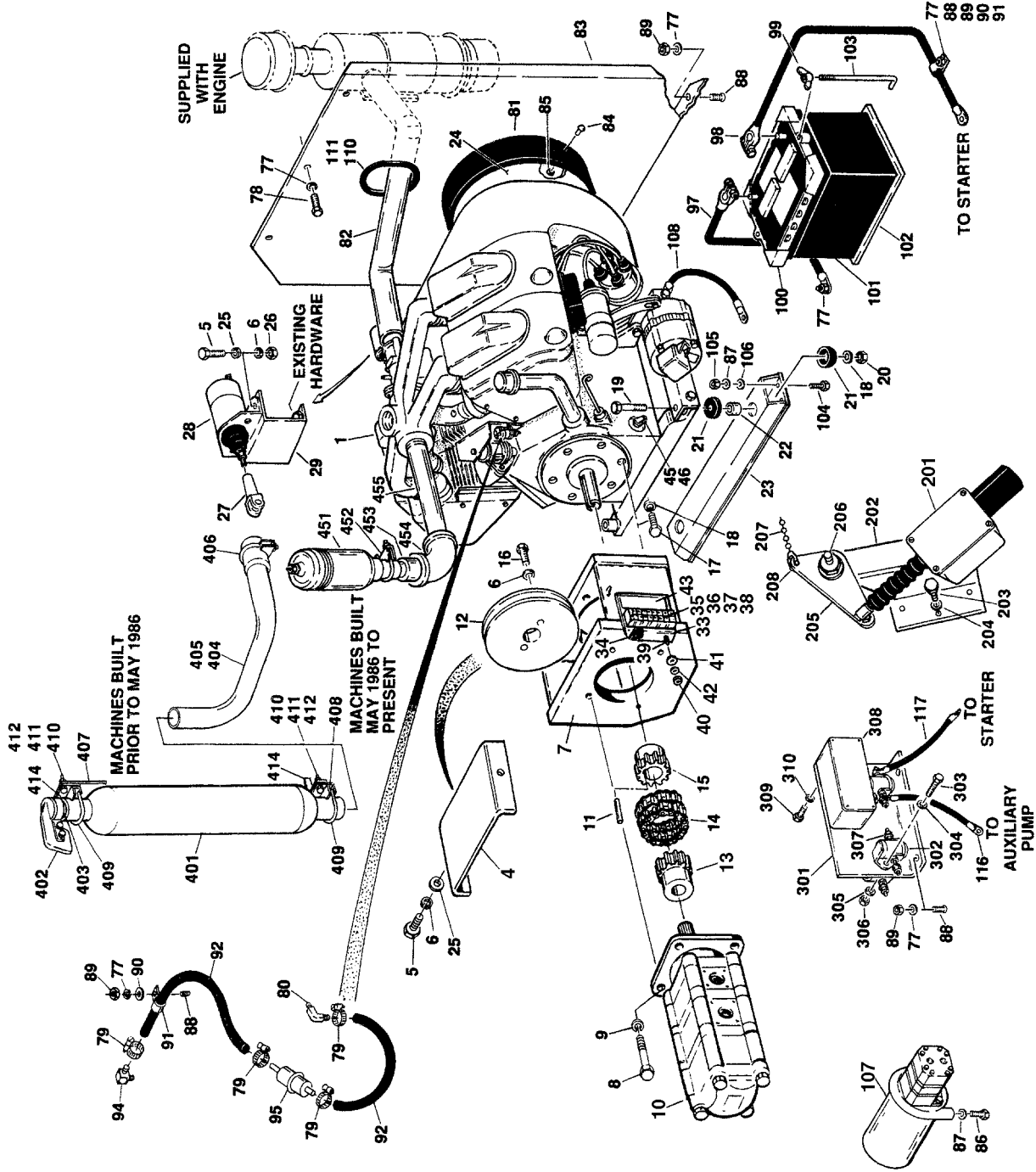



# SECTION 2 TURNTABLE

**FIGURE 2-36. WISCONSIN ENGINE INSTALLATION**

FIG & ITEM #	PART NUMBER	DESCRIPTION	QTY.	REV.
		<b>WISCONSIN ENGINE INSTALLATION</b>	Ref.	
	0236985	<b>ENGINE ASSEMBLY - STANDARD MACHINES WITH SINGLE SPEED DRIVE AND RACINE PROPORTIONAL VALVES</b>	Ref.	E
	0237285	<b>ENGINE ASSEMBLY - STANDARD MACHINES WITH 2 SPEED DRIVE AND RACINE PROPORTIONAL VALVES</b>	Ref.	C
	0238016	<b>ENGINE ASSEMBLY - STANDARD MACHINES WITH VICKERS PROPORTIONAL VALVES</b>	Ref.	D
	0238997	<b>ENGINE ASSEMBLY - DUAL FUEL MACHINES WITH VICKERS VALVES PROPORTIONAL (REFER TO FORD DUAL FUEL FOR LP COMPONENTS)</b>	Ref.	A
1	2000070	Engine - Wisconsin V465D	1	
2	Not Used			
3	Not Used			
4		Cover, Pump Adapter Options:		
	1670221	Cover, Pump Adapter (Machines with Racine Valves)	1	
		Adapter Cover Options (Machines with Vickers Valves):		
	1670221	Prior to July 1988		
	1670478	July 1988 to Present		
5	0641408	Bolt 1/4"-20NC x 1"	4	
6	4761400	Lockwasher 1/4"	7	
7		Adapter, Pump Options:		
	0080108	Adapter, Pump (Machines with Racine Valves)		
	0080143	Adapter, Pump (Machines with Vickers Valves)		
8	0641810	Bolt 1/2"-13NC x 1 1/4"	2	
9	4761800	Lockwasher 1/2"	2	
10		Pump Assembly Options:		
	3600107	Pump for Single Speed Drive Machines (See Figure 2-37 for Breakdown)		
		Pump Assembly Options (Machines with Vickers Valves):		
	3600072	Pump - Prior to July 1988 (See Figure 2-38 for Breakdown)		
	3600139	Pump - July 1988 to Present (See Figure 2-39 for Breakdown)		
11	2880619	Key, Square	1	
12	3580079	Pulley	1	
13		Coupling Options:		
	1660020	Coupling (Machines with Racine Valves)		
	1660144	Coupling (Machines with Vickers Valves)		
14	1260026	Chain	1	
15	1660133	Coupling	1	
16	0641412	Bolt 1/4"-20NC x 1 1/2"	2	
17	0642014	Bolt 5/8"-11NC x 1 3/4"	4	
18	4762000	Lockwasher 5/8"	8	
19	0642034	Bolt 5/8"-11NC x 4 1/4"	4	

**SECTION 2 TURNTABLE**

# SECTION 2 TURNTABLE

**FIGURE 2-36. WISCONSIN ENGINE INSTALLATION (CONTINUED)**

FIG & ITEM #	PART NUMBER	DESCRIPTION	QTY.	REV.
20	3312005	Locknut 5/8"-11NC	4	
21	3200062	Mount, Motor	8	
22	4560161	Tube	4	
23	4842285	Support, Engine	2	
24	3760235	Ring, Shroud	1	
25	4751400	Flatwasher 1/4"	5	
26	3311401	Nut 1/4"-20NC	3	
27	1360061	Clevis, Yoke	1	
28	3740028	Solenoid, Choice	1	
29	0901325	Bracket, Choke Solenoid	1	
30 to 32	Not Used			
33	0901401	Bracket, Terminal Strip (Machines with Vickers Valves Only)	1	
34	1320070	Clamp, Wire (Machines with Vickers Valves Only)	1	
35	1670414	Cover, Terminal Strip (Machines with Vickers Valves Only)	1	
36	3910812	Screw, Machine #8-32NC x 3/4" (Machines with Vickers Valves Only)	2	
37	4770800	Starwasher #8 (Machines with Vickers Valves Only)	2	
38	3310801	Nut #8-32NC (Machines with Vickers Valves Only)	2	
39	4300034	Stud (Welded on Part) (Machines with Vickers Valves Only)	2	
40	3311601	Nut 3/8"-16NC (Machines with Vickers Valves Only)	2	
41	4751600	Flatwasher 3/8" (Machines with Vickers Valves Only)	2	
42	4761600	Lockwasher 3/8" (Machines with Vickers Valves Only)	2	
43	1700820	Decal - Wire Identification (Machines with Vickers Valves Only)	1	
44	Not Used			
45	2180450	Fitting, Straight	1	
46	2200345	Fitting, 90°	1	
	0236986	<b>ENGINE INSTALLATION - STANDARD MACHINES WITH SINGLE SPEED DRIVE AND RACINE PROPORTIONAL VALVES</b>	Ref.	C
	0237286	<b>ENGINE INSTALLATION - STANDARD MACHINES WITH 2 SPEED DRIVE AND RACINE PROPORTIONAL VALVES</b>	Ref.	A
	0238017	<b>ENGINE INSTALLATION - STANDARD MACHINES WITH VICKERS PROPORTIONAL VALVES</b>	Ref.	A
	0238998	<b>ENGINE INSTALLATION - DUAL FUEL MACHINES WITH VICKERS PROPORTIONAL VALVES (REFER TO FORD DUAL FUEL FOR LP COMPONENTS)</b>	Ref.	C
77	4761400	Lockwasher 1/4"	16	
78	3900022	Screw, Self-Tapping 1/4" x 7/8"	3	
79	1320022	Clamp, Hose	2	
80	2220296	Fitting, 90°	1	
81	4280252	Strip, Rubber	47 in.	
82	2720262	Hose, Air Intake	1	
83	3380339	Baffle, Air	1	
84	3820009	Rivet	12	

**SECTION 2 TURNTABLE**

# SECTION 2 TURNTABLE

**FIGURE 2-36. WISCONSIN ENGINE INSTALLATION (CONTINUED)**

FIG & ITEM #	PART NUMBER	DESCRIPTION	QTY.	REV.
85	4750600	Flatwasher #6	12	
86	0641612	Bolt 3/8"-16NC x 1 1/2"	2	
87	4761600	Lockwasher 3/8"	10	
88	4300032	Stud (Welded on Part)	13	
89	3311401	Nut 1/4"-20NC	13	
90	4751400	Flatwasher 1/4"	8	
91	1320041	Clamp	7	
92	2720015	Hose	80 in.	
93	2200051	Plug, Pipe (Located at Tank - Not Shown)	1	
94	2220317	Fitting, 90°	1	
95	2120042	Filter, In-Line (Includes 2 Clamps)	1	
96	4300038	Stud (Welded on Part) (Located on Turntable to Mount Air Cleaner - Not Shown)	4	
97	1060046	Cable, Battery (- Batt to Ground)	1	
98	1060147	Cable, Battery (+ Batt to Starter)	1	
99	3300029	Wingnut	2	
100	0400002	Hold-Down, Battery	1	
101	0400003	Battery	1	
102	3980003	Masonite	1	
103	0232573	Rod, Hold-Down	2	
104	0641614	Bolt 3/8"-16NC x 1 3/4"	8	
105	3311605	Locknut 3/8"	8	
106	4751600	Flatwasher 3/8"	8	
107		Auxiliary Pump Assembly Options:	1	
	See Note	Auxiliary Pump Assembly (Machines with Racine Valves) <b>Note: Recommended using 3600071 pump in place of standard equipment 3600115 pump.</b>	1	
	See Note	Auxiliary Pump Options (Machines with Vickers Valves): <b>Note: When Pump Assembly cannot be identified or when replacing complete pump assembly recommend using 3600071.</b>	1	
	3600052	Pump Assembly - Stone Model DB001198 (Used prior to October 1990 on standard machine and prior to June 1989 on dual fuel machines).		
	7000483	Replacement Motor (Includes Coupling)	1	
	7004412	Replacement Coupling	1	
	7004416	Replacement Pump	1	
	2900164	Seal Kit - 7004416 Pump	1	
	3600141	Pump Assembly - JSB Model 1210429 (Used June 1989 to October 1989) (Except coupling, all other replacement component must be custom built - recommend using 3600071)		
	7004249	Replacement Coupling	1	
	3600071	Pump Assembly - JSB 1210080 and 1210382 (Used October 1990 to present)	1	
	7004436	Replacement Motor with Bracket	1	
	7004248	Replacement Motor without Bracket	1	

# SECTION 2 TURNTABLE

**FIGURE 2-36. WISCONSIN ENGINE INSTALLATION (CONTINUED)**

FIG & ITEM #	PART NUMBER	DESCRIPTION	QTY.	REV.
107 (cont'd)	7012576	Replacement Bracket	1	
	7004249	Replacement Coupling	1	
	7004247	Replacement Pump	1	
	Not Available	Seal Kit - 7004247 Pump	1	
108	1060045	Cable, Battery (Engine to Ground)	1	
109	0100020	Sealant, Pipe (Not Shown)	A/R	
110	2820001	Protector, Edge	1 ft.	
111	0100001	Adhesive #4061	A/R	
112	2750527	Hose (To Oil Pressure Gauge at Ground Control Box - Not Shown)	78 in.	
113	2220001	Fitting, Swivel (Located at Oil Pressure Gauge near Ground Control Box)	1	
114	2200261	Fitting, Coupling (Located at Oil Pressure Gauge near Ground Control Box)	1	
115	4420001	Tape, Sealant (Not Shown)	A/R	
116	0400008	Cable, Battery (Aux Relay to Aux Pump)	1	
117	1060054	Cable, Battery (Aux Relay to Starter)	1	
	0236992	<b>THROTTLE INSTALLATION - MACHINES WITH RACINE PROPORTIONAL VALVES</b>	Ref.	A
	0237687	<b>THROTTLE INSTALLATION - MACHINES WITH VICKERS PROPORTIONAL VALVES</b>	Ref.	-
201	Not Used	Actuator Assembly Options:		
	0060020	Actuator Assembly (Machines with Racine Valves)	1	
	7008807	Board, Circuit	1	
	7008821	Motor	1	
	7008822	Cover, Motor	1	
	7008804	Bellows, Rod	1	
	0060024	Actuator Assembly (Machines with Vickers Valves)	1	
	7008829	Board, Circuit	1	
	7008821	Motor	1	
	7008822	Cover, Motor	1	
	7008804	Bellows, Rod	1	
202	4842288	Bracket	1	
203	0641406	Bolt 1/4"-20NC x 3/4"	3	
204	4761400	Lockwasher 1/4"	3	
205	0200291	Arm	1	
206	3311605	Locknut 3/8"-16NC	1	
	4751600	Flatwasher 3/8"	2	
207	1260082	Chain	1 ft.	
208	1660083	Coupling	2	
	3430304	Pin, Clevis	1	
	3450203	Pin, Cotter	1	

**SECTION 2 TURNTABLE**

# SECTION 2 TURNTABLE

**FIGURE 2-36. WISCONSIN ENGINE INSTALLATION (CONTINUED)**

FIG & ITEM #	PART NUMBER	DESCRIPTION	QTY.	REV.
	0237297	<b>ELECTRICAL PANEL ASSEMBLY (MACHINES WITH RACINE PROPORTIONAL VALVES)</b>	Ref.	-
	0237874	<b>ELECTRICAL PANEL ASSEMBLY (MACHINES WITH VICKERS PROPORTIONAL VALVES) (NOT SHOWN)</b>	Ref.	B
301	3530425	Plate, Mounting	1	
302		Relay Options:	A/R	
	3740002	Relay (Machines with Racine Valves)	3	
	3740067	Relay (Machines with Vickers Valves)	2	
303	0641006	Bolt #10-24NC	2	
304	4751000	Flatwasher #10	2	
305	4761000	Lockwasher #10	2	
306	3311001	Nut #10-24NC	2	
307	3300220	Nut, Special	2	
308	0060021	Module, Actuator (Machines with Racine Valves Only)	1	
309	0641406	Bolt 1/4"-20NC x 3/4" (Machines with Racine Valves Only)	2	
310	4761400	Lockwasher 1/4" (Machines with Racine Valves Only)	2	
	0236990	<b>EXHAUST INSTALLATION - MACHINES BUILT PRIOR TO MAY 1986</b>	Ref.	A
401	3220058	Muffler	1	
402	1120169	Raincap	1	
403	0960960	Bushing	1	
404	4563021	Pipe, Exhaust	1	
405	4100025	Sleeve, Fiberglass	19 in.	
406	1320011	Clamp, Muffler	1	
407	4340420	Support (Upper)	1	
408	4340421	Support (Lower)	1	
409	1320019	Clamp	2	
410	0641408	Bolt 1/4"-20NC x 1"	4	
411	4761400	Lockwasher 1/4"	4	
412	3311401	Nut 1/4"-20NC	4	
413	Not Used			
414	4340470	Plate, Support	2	
	0237574	<b>EXHAUST INSTALLATION - MACHINES BUILT MAY 1986 TO PRESENT</b>	Ref.	A
451	3220043	Muffler	1	
452	1320019	Clamp	1	
453	2180593	Nipple	1	
454	2200349	Fitting, 90°	1	
455	2180671	Nipple	1	

**SECTION 2 TURNTABLE**

# SECTION 2 TURNTABLE

FIGURE 2-37. MAIN PUMP ASSEMBLY (MACHINES WITH RACINE PROPORTIONAL VALVES)

SECTION 2 TURNTABLE

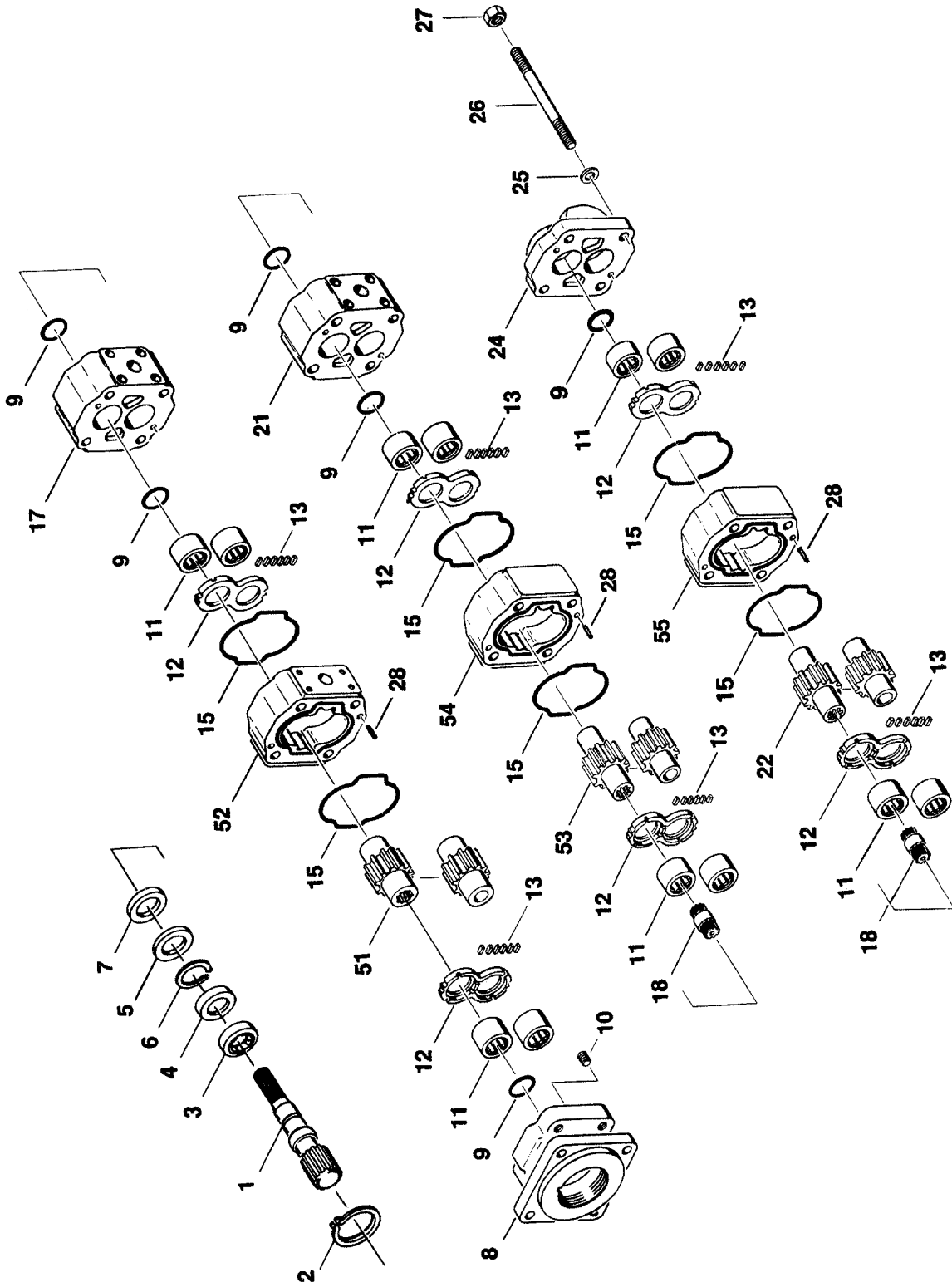

# SECTION 2 TURNTABLE

**FIGURE 2-37. MAIN PUMP ASSEMBLY (MACHINES WITH RACINE PROPORTIONAL VALVES)**

FIG & ITEM #	PART NUMBER	DESCRIPTION	QTY.	REV.
		<b>MAIN PUMP ASSEMBLY (MACHINES WITH RACINE PROPORTIONAL VALVES)</b>	Ref.	
		<b>PUMP ASSEMBLY (STANDARD PARTS)</b>	Ref.	
1	7000501	Shaft, Input	1	
2	7003162	Ring, Snap	1	
3	7000505	Bearing	1	
4	7003164	Spacer	1	
5	7003165	Ring, Bearing Retainer	1	
6	7003166	Ring, Retaining	1	
7	Kit	Seal, Lip	1	
8	7005496	Cover, Shaft End	1	
9	Kit	Seal, Ring	6	
10	7003103	Plug	1	
11	7003168	Bearing, Roller	12	
12	7005436	Plate, Thrust	6	
13	Kit	Seal, Pocket		
14	Not Used			
15	Kit	Seal, Gasket	6	
16	Not Used			
17	7005498	Carrier, Bearing - Ported	1	
18	7003174	Shaft, Connecting	2	
19	Not Used			
20	Not Used			
21	7005498	Carrier, Bearing - Ported	1	
22	7003177	Gear Set	1	
23	Not Used			
24	7000479	Cover, Port End	1	
25	7001293	Washer	4	
26	7003180	Stud	4	
27	7003114	Nut	4	
28	7005447	Pin, Dowel	8	
	2900120	----- Seal Kit (Includes Items 7, 9, 13 and 15)	1	

**SECTION 2 TURNTABLE**

# SECTION 2 TURNTABLE

**FIGURE 2-37. MAIN PUMP ASSEMBLY (MACHINES WITH RACINE PROPORTIONAL VALVES)**

FIG & ITEM #	PART NUMBER	DESCRIPTION	QTY.	REV.
	3600107	<b>PUMP ASSEMBLY - 1 1/4", 1 1/4" AND 1/2" GEAR SETS (DEUTZ AND WISCONSIN MACHINES WITH SINGLE SPEED DRIVE) (VARIABLE PARTS)</b>	Ref.	B
	3600113	<b>PUMP ASSEMBLY - 1", 1" AND 1/2" GEAR SETS (DEUTZ AND WISCONSIN MACHINES WITH 2 SPEED DRIVE AND FORD MACHINES WITH SINGLE SPEED DRIVE) (VARIABLE PARTS)</b>	Ref.	A
	3600125	<b>PUMP ASSEMBLY - 1", 3/4" and 1/2" GEAR SETS (FORD MACHINES WITH 2 SPEED DRIVE) (VARIABLE PARTS)</b>	Ref.	A
51		Gear Set Options:	1	
	7003189	Pump Assembly - 1 1/4, 1 1/4 & 1/2 Gear Sets		
	7003171	Pump Assembly - 1, 1 & 1/2 Gear Sets		
	7003171	Pump Assembly - 1, 3/4 & 1/2 Gear Sets		
52		Housing, Gear - With Ports Options:	1	
	7000481	Pump Assembly - 1 1/4, 1 1/4 & 1/2 Gear Sets		
	7005497	Pump Assembly - 1, 1 & 1/2 Gear Sets		
	7005538	Pump Assembly - 1, 3/4 & 1/2 Gear Sets		
53		Gear Set Options:	1	
	7003189	Pump Assembly - 1 1/4, 1 1/4 & 1/2 Gear Sets		
	7003171	Pump Assembly - 1, 1 & 1/2 Gear Sets		
	7003175	Pump Assembly - 1, 3/4 & 1/2 Gear Sets		
54		Housing, Gear - Without Ports Options:	1	
	7005500	Pump Assembly - 1 1/4, 1 1/4 & 1/2 Gear Sets		
	7005439	Pump Assembly - 1, 1 & 1/2 Gear Sets		
	7005539	Pump Assembly - 1, 3/4 & 1/2 Gear Sets		
55		Housing, Gear - Without Ports Options:	1	
	7003178	Pump Assembly - 1 1/4, 1 1/4 & 1/2 Gear Sets		
	7003178	Pump Assembly - 1, 1 & 1/2 Gear Sets		
	7005540	Pump Assembly - 1, 3/4 & 1/2 Gear Sets		

**SECTION 2 TURNTABLE**



# SECTION 2 TURNTABLE

FIGURE 2-37. MAIN PUMP ASSEMBLY (MACHINES WITH RACINE PROPORTIONAL VALVES)

FIG & ITEM #	PART NUMBER	DESCRIPTION	QTY.	REV.

**S  
E  
C  
T  
I  
O  
N  
  
2  
  
T  
U  
R  
N  
T  
A  
B  
L  
E**

# SECTION 2 TURNTABLE

FIGURE 2-38. MAIN PUMP ASSEMBLY (MACHINES WITH VICKERS PROPOR-TIONAL VALVES BUILT PRIOR TO MID 1987 - HAS ONE OUTLET IN END COVER)

SECTION 2 TURNTABLE

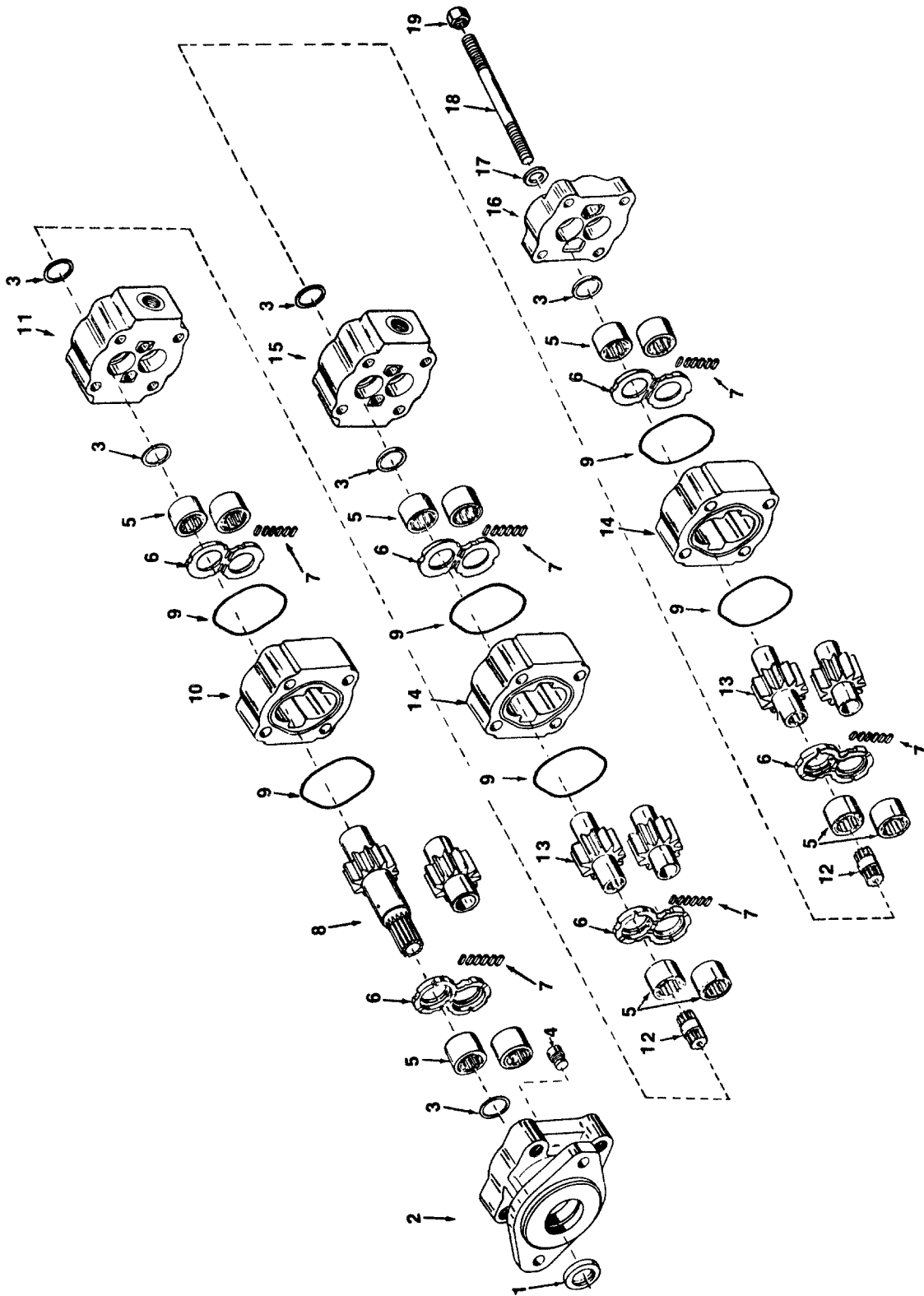

# SECTION 2 TURNTABLE

**FIGURE 2-38. MAIN PUMP ASSEMBLY (MACHINES WITH VICKERS PROPORTIONAL VALVES BUILT PRIOR TO MID 1987 - HAS ONE OUTLET IN END COVER)**

FIG & ITEM #	PART NUMBER	DESCRIPTION	QTY.	REV.
		<b>MAIN PUMP ASSEMBLY (MACHINES WITH VICKERS PROPORTIONAL VALVES BUILT PRIOR TO MID 1987 - HAS ONE OUTLET IN END COVER)</b>	Ref.	C
	3600072	<b>PUMP ASSEMBLY</b>	Ref.	
1	Kit	Seal, Lip	1	
2	7005509	Cover, End	1	
3	Kit	Seal, Ring	6	
4	7003103	Plug	1	
5	7003168	Bearing, Roller	12	
6	7005511	Plate, Thrust	6	
7	Kit	Seal, Pocket	3 strips	
8	7005505	Shaft and Gear	1 set	
9	Kit	Seal, Gasket	6	
10	7003176	Housing, Gear	1	
11	7005512	Carrier, Bearing	1	
12	7003174	Shaft, Connecting	2	
13	7003177	Gear Set	2 sets	
14	7003178	Housing, Gear	2	
15	7005513	Carrier, Bearing	1	
16	7005541	Cover, Rear	1	
17	7001293	Washer	4	
18	7005542	Stud	4	
19	7003114	Nut	4	
		-----		
	2900120	Kit, Seal (Kit Includes Items 1, 3, 7 and 9)	1	

**SECTION 2 TURNTABLE**

# SECTION 2 TURNTABLE

FIGURE 2-39. MAIN PUMP ASSEMBLY (MACHINES WITH VICKERS PROPORTIONAL VALVES BUILT MID 1987 TO PRESENT - HAS 2 OUTLETS IN END COVER)

SECTION 2 TURNTABLE

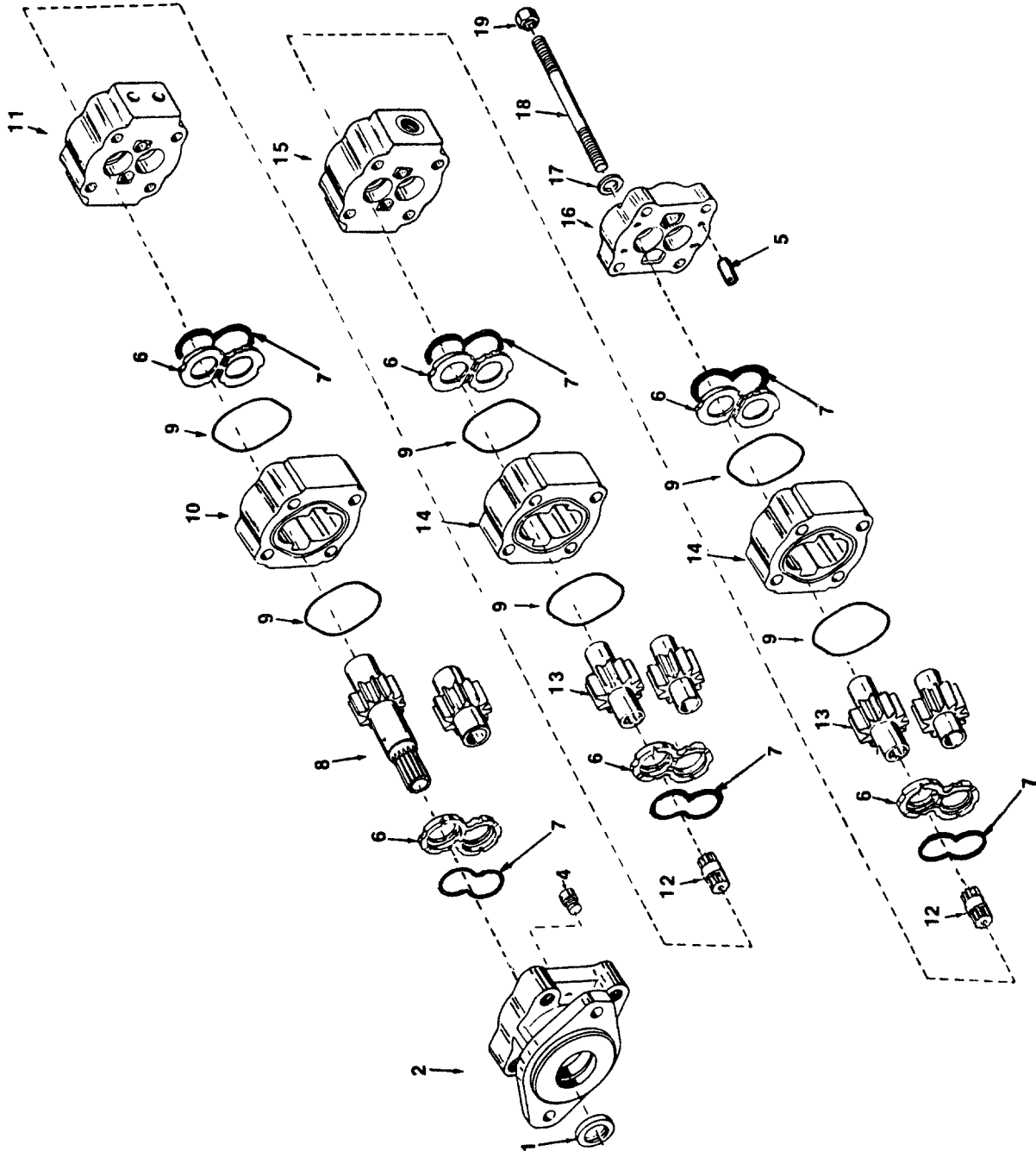

# SECTION 2 TURNTABLE

**FIGURE 2-39. MAIN PUMP ASSEMBLY (MACHINES WITH VICKERS PROPORTIONAL VALVES BUILT MID 1987 TO PRESENT - HAS 2 OUTLETS IN END COVER)**

FIG & ITEM #	PART NUMBER	DESCRIPTION	QTY.	REV.
	3600139	<b>MAIN PUMP ASSEMBLY (MACHINES WITH VICKERS PROPORTIONAL VALVES BUILT MID 1987 TO PRESENT - HAS 2 OUTLETS IN END COVER)</b>	Ref.	B
1	Kit	Seal, Lip	1	
2	7009513	Cover, End with Bushings	1	
3	Not Used			
4	7003103	Plug	1	
5	7009500	Dowel	12	
6	7009503	Plate, Thrust	6	
7	Kit	Seal, Channel	6	
8	7009509	Shaft and Gear	1 Set	
9	Kit	Seal, Gasket	6	
10	7009510	Housing, Gear	1	
11	7009508	Carrier, Bearing with Bushings	1	
12	7005599	Shaft, Connecting	2	
13	7005598	Gear Set	2	
14	7009504	Housing, Gear	1	
15	7009505	Carrier, Bearing with Bushings	1	
16	7009511	Cover, Rear with Bushings	1	
17	7005597	Washer	4	
18	7005562	Stud	4	
19	7005595	Nut	4	
		-----		
	7016913	Kit, Seal (Includes Items 1, 7 and 9)	1	

**SECTION 2 TURNTABLE**

# SECTION 2 TURNTABLE

FIGURE 2-40. TANKS INSTALLATION

SECTION 2 TURNTABLE

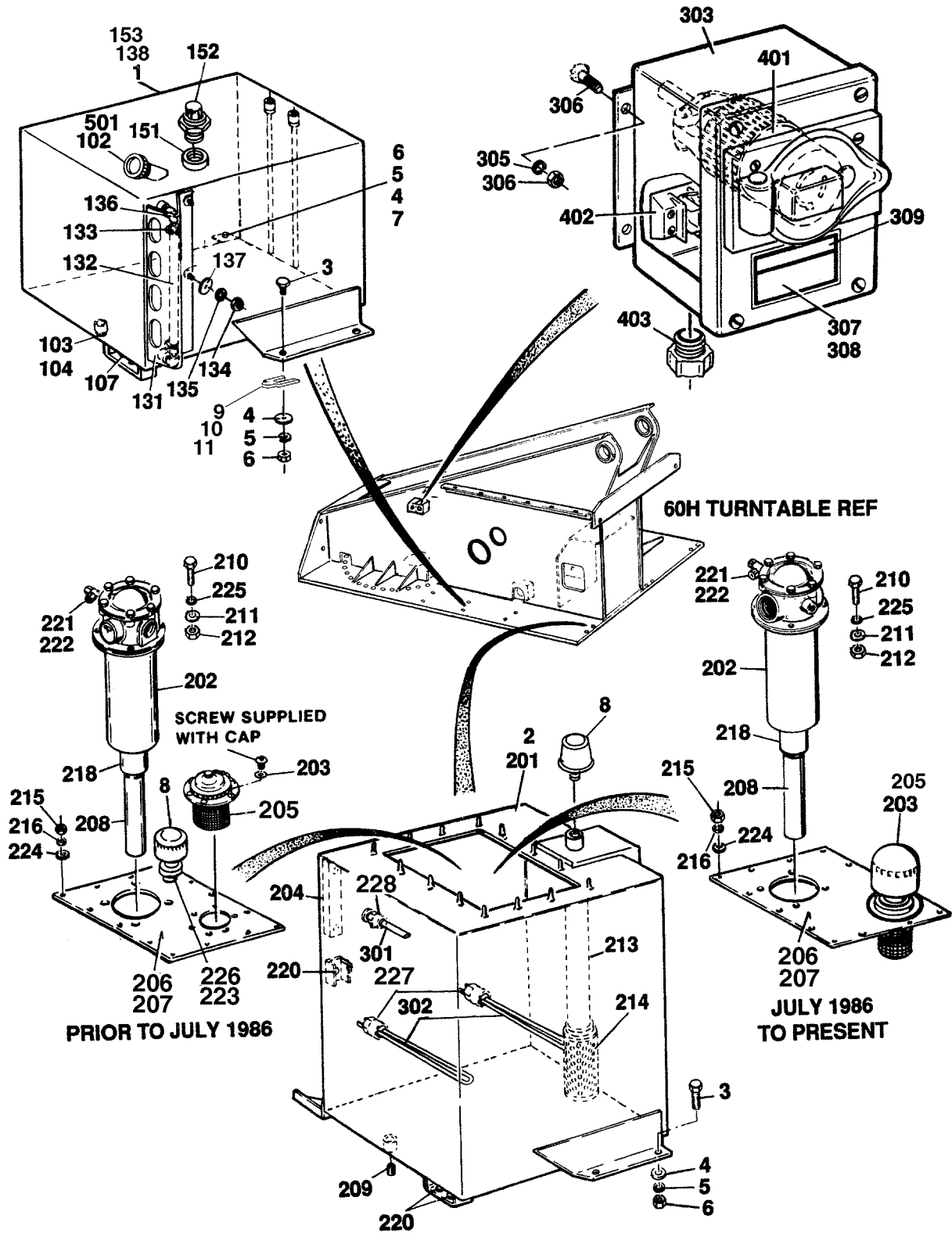

# SECTION 2 TURNTABLE

**FIGURE 2-40. TANKS INSTALLATION**

FIG & ITEM #	PART NUMBER	DESCRIPTION	QTY.	REV.
		<b>Note: For Piston Pump, U/L and Westinghouse Machines see Section 10.</b>		
	0236288	<b>FUEL AND HYDRAULIC TANKS INSTALLATION - MACHINES WITH STANDARD SIGHT GAUGE ON FUEL TANK</b>	Ref.	D
	0239337	<b>FUEL AND HYDRAULIC TANKS INSTALLATION - MACHINES WITH OPTIONAL MECHANICAL GAUGE ON FUEL TANK (PRIOR TO MAY 1995)</b>	Ref.	A
	0236874	<b>FUEL AND HYDRAULIC TANKS INSTALLATION - MACHINES WITH HEATERS BUILT PRIOR TO MAY 1993</b>	Ref.	G
	0254192	<b>FUEL AND HYDRAULIC TANKS INSTALLATION - MACHINES WITH HEATERS BUILT MAY 1993 TO PRESENT</b>	Ref.	A
	0239255	<b>HOOD BRACKET AND HYDRAULIC TANK INSTALLATION - LP ONLY MACHINES</b>	Ref.	B
1		Fuel Tank Assembly Options (See Items 101-152 for Breakdown):	1	
	0236285	Machines with Standard Sight Gauge on Fuel Tank (Prior to June 1995)		
	0255823	Machines with Standard Sight Gauge on Fuel Tank (June 1995 to Present)		
	0239332	Machines with Optional Mechanical Gauge on Fuel Tank		
	0236285	Machines with Heaters		
	0901188	Machines with LP Only (Bracket, Hood) (Not Shown - Located in place of Fuel Tank)	1	
2		Hydraulic Tank Assembly Options (See Items 201-228 for Breakdown):	1	
		Machines with Standard Sight Gauge on Fuel Tank:		
	See Note	Tank - Prior to July 1986		
		<b>Note: Use 4400214 in place of Standard 0236286.</b>		
	4400214	Tank - July 1986 to Present		
		Machines with Optional Mechanical Gauge on Fuel Tank:		
	4400214	Hydraulic Tank Assembly		
		Machines with Heaters:		
	See Note	Tank - Prior to December 1988		
		<b>Note: Use 4400268 in place of standard modified 0236286 Tank</b>		
	4400268	Tank - December 1988 to Present		
		Machines with LP Only:		
	4400214	Hydraulic Tank Assembly	1	
3	0641614	Bolt 3/8"-16NC x 1 3/4"	6	
4	4751600	Flatwasher 3/8"	8	
5	4761600	Lockwasher 3/8"	8	
6	3311601	Nut 3/8"-16NC	8	
7	4300034	Stud (Welded on Part)	2	

SECTION 2 TURNTABLE

# SECTION 2 TURNTABLE

**FIGURE 2-40. TANKS INSTALLATION (CONTINUED)**

FIG & ITEM #	PART NUMBER	DESCRIPTION	QTY.	REV.
8		Breather Options:	1	
	1340021	Breather (Prior to July 1986)		
	1340046	Breather (July 1986 to Present)		
9	4070410	Shim 1/16 (May 1995 to Present)	A/R	
10	4070411	Shim 1/8 (May 1995 to Present)	A/R	
11	4070412	Shim 3/16 (May 1995 to Present)	A/R	
		<b>FUEL TANK ASSEMBLY (STANDARD PARTS)</b>	Ref.	
101	Not Used			
102	1120314	Cap, Fill	1	
103	2200052	Plug, Pipe	1	
104	0100020	Sealant, Pipe	A/R	
105	Not Used			
106	Not Used			
107	33000205	Nut, Retainer	3	
	0236285	<b>FUEL TANK ASSEMBLY WITH SIGHT GAUGE (PRIOR TO JUNE 1995) (VARIABLE PARTS)</b>	Ref.	5
	0255823	<b>FUEL TANK ASSEMBLY WITH SIGHT GAUGE (JUNE 1995 TO PRESENT) (VARIABLE PARTS)</b>	Ref.	2
131	4060574	Protector, Gauge	1	
132	4562516	Tube, Sight	15in/ 38cm	
133	1320022	Clamp, Hose	2	
134	3311401	Nut 1/4"-20NC	3	
135	4761400	Lockwasher 1/4"	3	
136	2180467	Fitting, 90° Barbed	2	
137	4751400	Flatwasher 1/4"	3	
138		Tank, Fuel Options:	1	
	4841917	Prior to June 1995		
	4400385	June 1995 to Present		
	0239332	<b>FUEL TANK ASSEMBLY WITH MECHANICAL GAUGE (VARIABLE PARTS)</b>	Ref.	2
151	2200268	Coupling	1	
152	2420051	Gauge, Fuel	1	
153	4841917	Tank, Fuel	1	

**SECTION 2 TURNTABLE**



# SECTION 2 TURNTABLE

**FIGURE 2-40. TANKS INSTALLATION (CONTINUED)**

FIG & ITEM #	PART NUMBER	DESCRIPTION	QTY.	REV.
		<b>HYDRAULIC TANK ASSEMBLY (STANDARD PARTS)</b>	Ref.	
	0236286	<b>HYDRAULIC TANK ASSEMBLY - MACHINES WITH AND WITHOUT HEATERS BUILT PRIOR TO JULY 1986 (VARIABLE PARTS)</b>	Ref.	D
	4400214	<b>HYDRAULIC TANK ASSEMBLY - MACHINES WITHOUT HEATERS BUILT JULY 1986 TO PRESENT (VARIABLE PARTS)</b>	Ref.	C
	4400268	<b>HYDRAULIC TANK ASSEMBLY - MACHINES WITH HEATERS BUILT JULY 1986 TO PRESENT (VARIABLE PARTS)</b>	Ref.	B
201	4841918	Tank Hydraulic	1	
202	2120103	Filter Assembly	1	
	2120107	Element, Filter	1	
	7004244	Pressure, Indicator	1	
	7012559	Gasket (Between filter & tank)	1	
	7016333	O-Ring	1	
203	4740338	Washer, Sealing	6	
204	2420080	Gauge, Level	1	
	7016664	Washer, Sealing	2	
205		Cap Options:	1	
	1120287	Cap and Strainer (Machines with & without Heaters Built Prior to July 1986)		
	1340045	Cap and Breather (Machines with & without Heaters Built July 1986 to Present)		
206		Lid Options:	1	
	4842375	Machines with & without Heaters Built Prior to July 1986		
	1670468	Machines with & without Heaters Built July 1986 to Present		
207		Hardware Options:		
	0100009	Sealant, RTV (Machines with & without Heaters Built Prior to July 1986)	A/R	
	3960371	Gasket (Machines with & without Heaters Built July 1986 to Present)	1	
208	2180605	Pipe	1	
209	3520022	Plug, Magnetic	1	
210	0641612	Bolt 3/8"-16NC x 1 1/2"	4	
211	4761600	Lockwasher 3/8"	4	
212	3311601	Nut 3k/8"-16NC	4	
213	2180606	Nipple, Pipe	1	
214	2120104	Filter	1	
215	3311401	Nut 14"-20NC	A/R	
216	4761400	Lockwasher 1/4"	A/R	
217	0100020	Sealant, Pipe	A/R	
218	2200268	Fitting, Coupling	1	
219	2200203	Plug, Pipe 1/2"	1	
220	3300205	Nut, Retainer 5/16"-18NC	3	
221	2180614	Fitting, Straight	1	
222	2220728	Fitting, Tee	1	

**SECTION 2 TURNTABLE**

# SECTION 2 TURNTABLE

**FIGURE 2-40. TANKS INSTALLATION (CONTINUED)**

FIG & ITEM #	PART NUMBER	DESCRIPTION	QTY.	REV.
223		Fitting, Coupling Options:	A/R	
	2200265	Machines with & without Heaters Built Prior to July 1986	1	
	Not Required	Machines with & without Heaters Built July 1986 to Present	0	
224	4751400	Flatwasher 1/4"	A/R	
225	4740322	Washer, Sealing	4	
226		Nipple Options:	A/R	
	2180053	Machines with & without Heaters Built Prior to July 1986	1	
	Not Required	Machines with & without Heaters Built July 1986 to Present	0	
227		Fitting, Coupling Options:	A/R	
	Not Required	Machines with & without Heaters Built Prior to July 1986	0	
	Not Required	Machines without Heaters Built July 1986 to Present	0	
	2180399	Machines with Heaters Built July 1986 to Present	2	
228		Fitting, Coupling Options:	A/R	
	Not Required	Machines with & without Heaters Built Prior to July 1986	0	
	Not Required	Machines without Heaters Built July 1986 to Present	0	
	2180398	Machines with Heaters Built July 1986 to Present	1	
	0236874	<b>HEATERS AND CONTROLS INSTALLATION</b>	Ref.	G
301	1600043	Control, Thermoswitch	1	
302	2580018	Heater, Immersion	2	
303	0231756	Junction Box Assembly (See Items 401-403 for Breakdown)	2	
304	3311401	Nut 1/4"-20NC	4	
305	4761400	Lockwasher	4	
306	4300031	Stud (Welded on Part)	4	
307	3251836	Nameplate - Engine/Battery Manifold Heater (Left Box)	1	
308	3251272	Nameplate - Hydraulic Oil Tank Heater (Right Box)	1	
309	3251243	Nameplate - 120V-60Hz	2	
	0231756	<b>JUNCTION BOX ASSEMBLY</b>	Ref.	C
401	4460137	Receptacle, Female (1 Per Assembly)	1	
	4460082	Receptacle, Male (1 Per Assembly)	1	
402	4460007	Strip, Terminal (1 Per Assembly)	1	
403	4460049	Connector, Strain Relief (3 Per Assembly)	3	

**SECTION 2 TURNTABLE**

# SECTION 2 TURNTABLE

**FIGURE 2-40. TANKS INSTALLATION (CONTINUED)**

FIG & ITEM #	PART NUMBER	DESCRIPTION	QTY.	REV.
501		<b>FUEL CAP INSTALLATIONS</b>	Ref.	
	0257365	<b>FUEL CAP (STANDARD)</b>	Ref.	1
	0257366	<b>FUEL CAP RED (PROTECTOSEAL)</b>	Ref.	2
	0258626	<b>FUEL CAP BLUE (PROTECTOSEAL)</b>	Ref.	1
		Fuel Cap Options:	1	
	1120314	Standard		
	1120367	Protectoseal (Red)		
1120512	Protectoseal (Blue)			

SECTION 2 TURNTABLE

# SECTION 2 TURNTABLE

FIGURE 2-41. LP TANKS INSTALLATION

SECTION 2 TURNTABLE

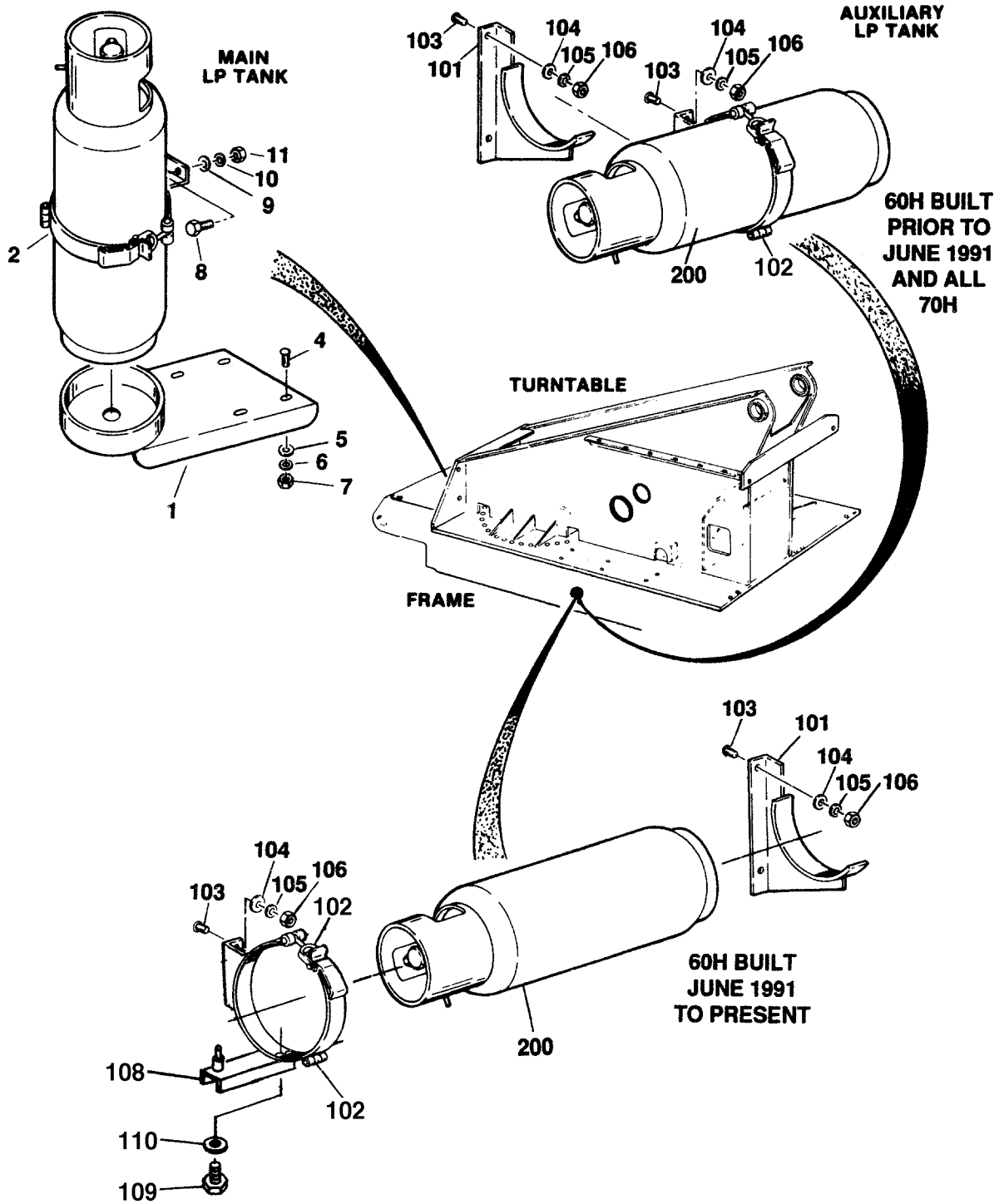

# SECTION 2 TURNTABLE

**FIGURE 2-41. LP TANKS INSTALLATION**

FIG & ITEM #	PART NUMBER	DESCRIPTION	QTY.	REV.
		<b>LP TANKS INSTALLATION</b>	Ref.	
	0236674	<b>LP TANKS INSTALLATION - TURNTABLE MOUNTED</b>	Ref.	E
1	0901345	Bracket	1	
2		Clamp Options:	1	
	1320023	Prior to May 1994		
	1320126	May 1994 to Present		
3	Not Used			
4	4300045	Stud (Welded on Part)	4	
5	4751800	Flatwasher 1/2"	4	
6	4761800	Lockwasher 1/2"	4	
7	33111801	Nut 1/2"-13NC	4	
8	0641508	Bolt 5/16"-18NC x 1"	2	
9	4751500	Flatwasher 5/16"	2	
10	4761500	Lockwasher 5/16"	2	
11	3311501	Nut 5/16"-18NC	2	
12	Not Used			
13	Not Used			
14	2540003	Grommet (Not Shown - Located in Hood)	4 in/10cm	
15	0100001	Adhesive (Use with Item 14)	A/R	
	0236674	<b>LP TANKS INSTALLATION - FRAME MOUNTED FOR 60H BUILT PRIOR TO JUNE 1991 AND 70H BUILT PRIOR TO MAY 1994</b>	Ref.	E
	0238916	<b>LP TANKS INSTALLATION - FRAME MOUNTED FOR 60H BUILT PRIOR TO JUNE 1991 AND 70H BUILT PRIOR TO MAY 1994</b>	Ref.	C
	0252048	<b>LP TANKS INSTALLATION - FRAME MOUNTED FOR 60H BUILT JUNE 1991 TO PRESENT</b>	Ref.	B
	0236674	<b>LP TANKS INSTALLATION - FRAME MOUNTED FOR 70H BUILT MAY 1994 TO PRESENT</b>	Ref.	E
	0238916	<b>LP TANKS INSTALLATION - FRAME MOUNTED FOR 70H SPARE TANK</b>	Ref.	D
101	0900935	Bracket	1	
102		Clamp Options:	1	
	1320023	60H (Built Prior to June 1991) 70H (Built Prior to May 1994)		
	1320126	60H (Built June 1991 to Present) 70H (Built May 1994 to Present)		
	1320023	70H Spare Tank		
103	4300034	Stud (Welded on Part)	4	
104	4751600	Flatwasher 3/8"	4	
105	4761600	Lockwasher 3/8"	4	
106	3311601	Nut 3/8"-16NC	4	
107	1320127	Toggle and Nut Clamp	1	
108	3200332	Mount, LP Tank	1	
109	0641403	Bolt 1/4"-20NC x 3/8"	2	
110	4761400	Lockwasher 1/4"	2	

# SECTION 2 TURNTABLE

**FIGURE 2-41. LP TANKS INSTALLATION (CONTINUED)**

FIG & ITEM #	PART NUMBER	DESCRIPTION	QTY.	REV.
		<b>LP TANK OPTIONS</b>	Ref.	
200	4400275	Tank - 43.5 Lb. Liquid Withdrawal (Aluminum)	2	
	4400038	Tank - 43.5 Lb. Vapor Withdrawal	2	
	4400420	Tank - 43.5 Lb. Liquid Withdrawal (Steel)	2	

**SECTION 2 TURNTABLE**

# SECTION 2 TURNTABLE

FIGURE 2-41. LP TANKS INSTALLATION (CONTINUED)

FIG & ITEM #	PART NUMBER	DESCRIPTION	QTY.	REV.

**S  
E  
C  
T  
I  
O  
N  
  
2  
  
T  
U  
R  
N  
T  
A  
B  
L  
E**

# SECTION 2 TURNTABLE

FIGURE 2-42. GROUND CONTROL COMPONENTS INSTALLATION (MACHINES WITH RACINE PROPORTIONAL VALVES)

SECTION 2 TURNTABLE

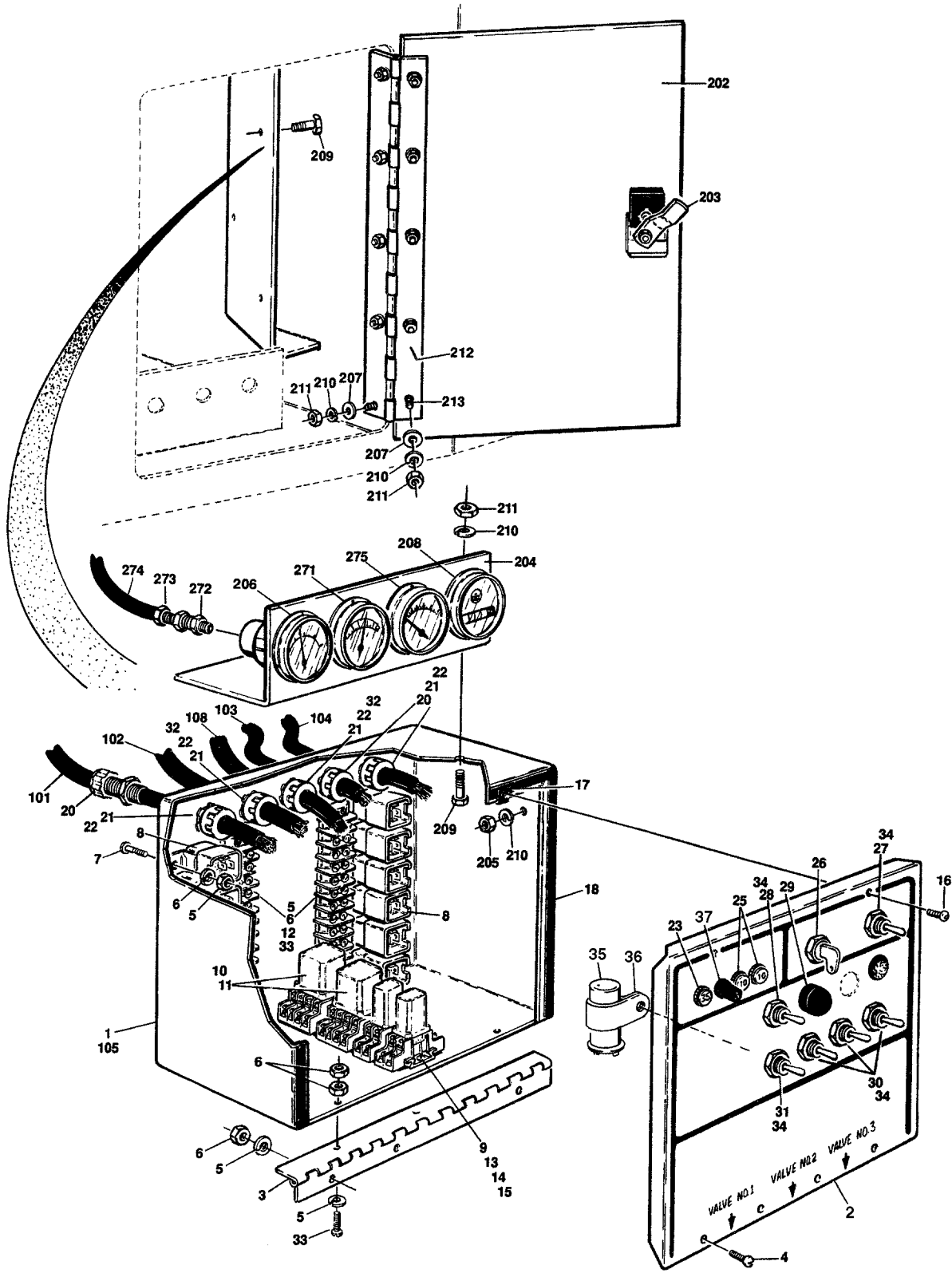



# SECTION 2 TURNTABLE

**FIGURE 2-42. GROUND CONTROL COMPONENTS INSTALLATION (MACHINES WITH RACINE PROPORTIONAL VALVES)**

FIG & ITEM #	PART NUMBER	DESCRIPTION	QTY.	REV.
		<b>GROUND CONTROL BOX ASSEMBLIES</b>	Ref.	
	0236506	<b>MACHINES WITH SOLENOID THROTTLE BUILT PRIOR TO OCTOBER 1985</b>	Ref.	B
	0237067	<b>MACHINES WITH ADECO THROTTLE BUILT OCTOBER 1985 TO PRESENT</b>	Ref.	C
1	0860487	Box	1	
		Lid Options:	1	
	3251522	Prior to October 1985		
	3251650	October 1985 to Present		
3	2600093	Hinge	1	
4	3911006	Screw, Round Head #10-24NC x 3/8"	4	
5	4761000	Lockwasher #10	A/R	
6	3311001	Nut #10-24NC	A/R	
7	3911008	Screw, Round Head #10-24NC x 1/2"	12	
8	3740049	Relay - SPDT	12	
9	4751000	Flatwasher #10	3	
10	3740016	Relay - 3PDT	2	
11	4120002	Socket, Relay	2	
12	4460263	Strip, Terminal	2	
13	3910610	Screw, Round Head #6-32NC x 5/8"	A/R	
14	4760600	Lockwasher #6	A/R	
15	3310601	Nut #6-32NC	A/R	
16	0750806	Screw #8 x 3/4"	2	
17	3300177	Nut, Tinnerman	2	
18	4280237	Strip, Rubber	33 in	
19	0100001	Adhesive (Not Shown)	A/R	
20	4460051	Connector, Strain Relief	3	
21	3300048	Nut, Conduit	4	
22	0960238	Bushing	4	
23	4360186	Breaker, Circuit - 35 Amp	1	
24	Not Used			
25	4360069	Breaker, Circuit - 10 Amp	3	
26	4360003	Switch, Key	1	
	2860002	Key, Replacement	1	
27	4360073	Switch, Toggle	1	
28	4360199	Switch, Toggle	1	
29	4360016	Switch, Push Button	1	
	0840004	Boot	1	
30	4360202	Switch, Toggle	3	
31	4360204	Switch, Toggle	1	
32	4460071	Connector, Strain Relief	1	
33	3911012	Screw, Round Head #10-24NC x 3/4"	A/R	
34	3790012	O-Ring	6	
35		Flasher Options:	1	
	4360089	Prior to October 1985		
	Not Required	October 1985 to Present		

# SECTION 2 TURNTABLE

**FIGURE 2-42. GROUND CONTROL COMPONENTS INSTALLATION (MACHINES WITH RACINE PROPORTIONAL VALVES) (CONTINUED)**

FIG & ITEM #	PART NUMBER	DESCRIPTION	QTY.	REV.
36	1320060	Clamp Options: Prior to October 1985	1	
	Not Required	October 1985 to Present		
37	4360212	Breaker, Circuit - 3 Amp (October 1985 to Present)	1	
		<b>HARNES INSTALLATIONS OPTIONS:</b>	Ref.	
	0860501	<b>MACHINES WITHOUT PROP TELE AND WITH SOLENOID THROTTLE BUILT PRIOR TO OCTOBER 1985</b>	Ref.	-
	0860508	<b>MACHINES WITHOUT PROP TELE AND WITH ADECO THROTTLE BUILT OCTOBER 1985 TO DECEMBER 1985</b>	Ref.	A
	0860518	<b>MACHINES WITHOUT PROP TELE AND WITH ADECO THROTTLE BUILT DECEMBER 1985 TO PRESENT</b>	Ref.	-
	0860488	<b>MACHINES WITH PROP TELE AND WITH SOLENOID THROTTLE BUILT PRIOR TO OCTOBER 1985</b>	Ref.	-
	0860519	<b>MACHINES WITH PROP TELE AND WITH ADECO THROTTLE BUILT OCTOBER 1985 TO PRESENT</b>	Ref.	-
101	4920454	Harness - 16/24 to Boom Options: Machines Without/With Prop Tele and with Solenoid Throttle (Prior to October 1985)	1	
	Not Required	Machines Without/With Prop Tele and with Adeco Throttle (October 1985 to Present)		
102	4920455	Harness - 12/4 to Boom Options: Machines Without/With Prop Tele and with Solenoid Throttle (Prior to October 1985)	1	
	Not Required	Machines Without/With Prop Tele and with Adeco Throttle (October 1985 to Present)		
103	4920463	Harness - Box to Engine Options: Machines Without/With Prop Tele and with Solenoid Throttle (Prior to October 1985)	1	
	4920528	Machines Without/With Prop Tele and with Adeco Throttle (October 1985 to Present)		
104	4920462	Harness - Box to Valves Options: Machines Without Prop Tele and with Solenoid Throttle (Prior to October 1985)	1	
	4920461	Machines With Prop Tele and with Solenoid Throttle (Prior to October 1985)		
	4920461	Machines Without Prop Tele and with Adeco Throttle (October 1985 to December 1985)		
	4920462	Machines With Prop Tele and with Adeco Throttle (October 1985 to Present)		
105		Ground Control Box Assembly (See Items 1-54 for Breakdown)	1	
	0236506	Machines Without/With Prop Tele and with Solenoid Throttle (Prior to October 1985)		
	0236506	Machines Without Prop Tele and with Adeco Throttle (October 1985 to December 1985)		

SECTION 2 TURNTABLE

# SECTION 2 TURNTABLE

**FIGURE 2-42. GROUND CONTROL COMPONENTS INSTALLATION (MACHINES WITH RACINE PROPORTIONAL VALVES) (CONTINUED)**

FIG & ITEM #	PART NUMBER	DESCRIPTION	QTY.	REV.
105 (cont'd)	0237067	Machines Without Prop Tele and with Adeco Throttle (December 1985 to Present)		
	0237067	Machines With Prop Tele and with Adeco Throttle (October 1985 to Present)		
106	Not Used			
107	Not Used			
108	1060016	Cable, Electrical - 16/3 to Limit Switches	12 ft.	
	0236886	<b>GROUND CONTROL INSTALLATIONS (WITHOUT PROP TELE)</b>	Ref.	D
	0236290	<b>GROUND CONTROL INSTALLATIONS (WITH PROP TELE)</b>	Ref.	J
201	Not Used			
202		Door Options:	1	
	1780146	Door - 14" W x 20 1/2" H (Prior to May 1985)		
	1780184	Door - 14" W x 20 1/2" H (May 1985 to March 1991)		
	1780234	Door - 17 5/8" W x 22 1/2" H (March 1991 to Present)		
203	2940042	Latch	1	
204	3380309	Panel, Gauge	1	
205	3300182	Nut, Retainer	3	
206	2420006	Ammeter	1	
207	4751400	Flatwasher 1/4"	10	
208	2420009	Hourmeter	1	
209	0641408	Bolt 1 1/4"-20NC x 1"	6	
210	4761400	Lockwasher 1/4"	16	
211	3311401	Nut 1/4"-20NC	13	
212	4300031	Stud (Welded on Part)	5	
213	2600094	Hinge	1	
214	0100011	Loctite #242 (Not Shown)	A/R	
		<b>GAUGES INSTALLATION (FROM ENGINE INSTALLATION) (VARIABLE PARTS)</b>	Ref.	
271		Oil Pressure Gauge Options:	1	
	2420030	Deutz Powered Machines		
	2420035	Ford Powered Machines		
	Consult Factory	Wisconsin Powered Machines		
272	2420001	Fitting, Swivel	1	
273	2200261	Fitting, Coupling	1	
274		Hose Options:	A/R	
	Consult Factory	Ford and Deutz Powered Machines		
	2750527	Wisconsin Powered Machines		
275		Temperature Gauge Options:	A/R	
	Not Required	Deutz Powered Machines		
	2420019	Ford Powered Machines		
	Not Required	Wisconsin Powered Machines		

**SECTION 2 TURNTABLE**

# SECTION 2 TURNTABLE

FIGURE 2-43. GROUND CONTROL COMPONENTS INSTALLATION (MACHINES WITH VICKERS PROPORTIONAL VALVES)

SECTION 2 TURNTABLE

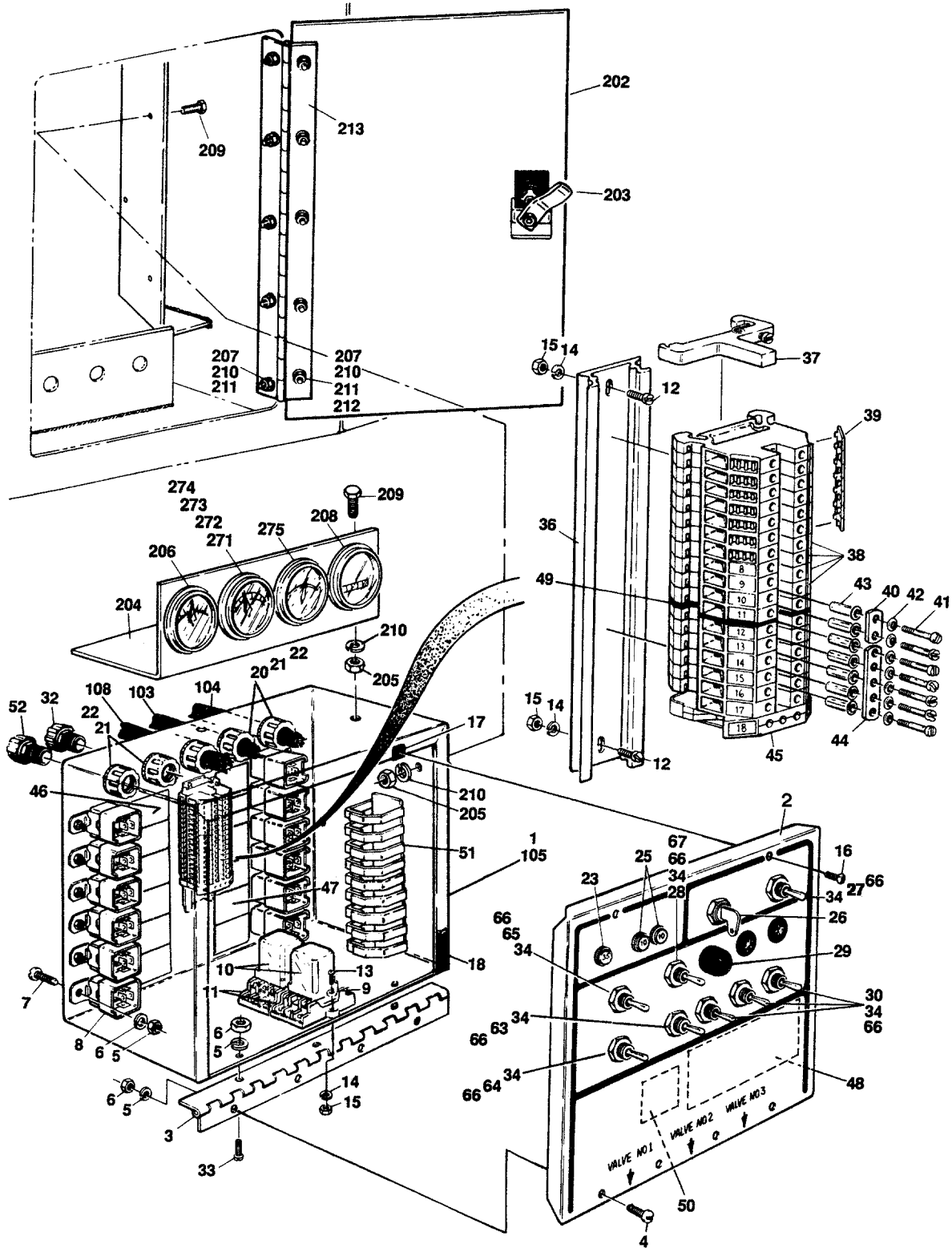

# SECTION 2 TURNTABLE

**FIGURE 2-43. GROUND CONTROL COMPONENTS INSTALLATION (MACHINES WITH VICKERS PROPORTIONAL VALVES)**

FIG & ITEM #	PART NUMBER	DESCRIPTION	QTY.	REV.
		<b>Note: See Section 10 for U/L Approved Ground Control Box</b>		
	0237855	<b>GROUND CONTROL BOX ASSEMBLY - MACHINES WITH STANDARD CAPACITY BUILT PRIOR TO MAY 1994</b>	Ref.	G
	0860908	<b>GROUND CONTROL BOX ASSEMBLY - MACHINES WITH STANDARD CAPACITY BUILT MAY 1994 TO PRESENT</b>	Ref.	4
	0251659	<b>GROUND CONTROL BOX ASSEMBLY - MACHINES WITH 750 LBS. CAPACITY BUILT PRIOR TO MAY 1994</b>	Ref.	-
	0860924	<b>GROUND CONTROL BOX ASSEMBLY - MACHINES WITH 750 LBS. CAPACITY BUILT MAY 1994 TO PRESENT</b>	Ref.	A
1	0860547	Box	1	
2		Lid Options:	1	
	3251650	Machines with Standard Capacity (Built Prior to May 1994)		
	3252343	Machines with Standard Capacity (Built May 1994 to S/N 48804)		
	3252638	Machines with Standard Capacity (S/N 48804 to Present)		
	3252088	Machines with 750 Lbs. Capacity (Built Prior to May 1994)		
	3252344	Machines with 750 Lbs. Capacity (Built May 1994 to Present)		
3	2600093	Hinge	1	
4	3911006	Screw, Round Head #10-24NC x 3/8"	4	
5	4761000	Lockwasher #10	20	
6	3311001	Nut #10-24NC	19	
7	3911008	Screw, Round Head #10-24NC x 1/2"	12	
8	3740049	Relay - SPDT	12	
9	4751000	Flatwasher #10	3	
10	3740016	Relay - 3PDT	2	
11	4120002	Socket, Relay	2	
12	3910606	Screw, Round Head #6-32NC x 3/8"	2	
13	3910610	Screw, Round Head #6-32MC x 5/8"	3	
14	4760600	Lockwasher #6	5	
15	3310601	Nut #6-32NC	5	
16	0750806	Screw #8 x 3/4"	2	
17	3300177	Nut, Tinnerman	2	
18	4420037	Strip, Rubber	33 in.	
19	0100001	Adhesive (Not Shown)	A/R	
20	4460051	Connector, Strain Relief	3	
21	3300048	Nut, Conduit	4	
22	0960238	Bushing	4	
23	4360186	Breaker, Circuit - 35Amp	1	
24	Not Used			

**SECTION 2 TURNTABLE**

# SECTION 2 TURNTABLE

**FIGURE 2-43. GROUND CONTROL COMPONENTS INSTALLATION (MACHINES WITH VICKERS PROPORTIONAL VALVES) (CONTINUED)**

FIG & ITEM #	PART NUMBER	DESCRIPTION	QTY.	REV.
25	4360069	Breaker, Circuit - 10 Amp	2	
26		Switch, Key Options:	1	
	4360003	Prior to S/N 48804		
	4360466	S/N 48804 to Present		
		Key, Replacement Options:	1	
	2860002	Prior to S/N 48804		
	2860030	S/N 48804 to Present	1	
	4070991	Shim.125 (S/N 48804 to Present Only)	A/R	
	4070987	Shim.015 (S/N 48804 to Present Only)	A/R	
	3910804	Screw #8-32NC x 1/4 (S/N 48804 to Present Only)	2	
27		Switch, Toggle Options:	1	
	4360073	Built Prior to May 1994		
	4360201	Built May 1994 to Present		
28	4360199	Switch, Toggle	1	
29	4360274	Switch, Push Button	1	
30	4360202	Switch, Toggle	3	
31	Not Used			
32	4460071	Connector, Strain Relief	1	
33	3911012	Screw, Round Head #10-24NC x 3/4"	3	
34	3790012	O-Ring	6	
35	Not Used			
36	3640492	Rail (Prior to May 1995)	6 in.	
	3640555	Rail (May 1995 to Present)	1	
37	4460299	Stop, Terminal	1	
38	4460298	Strip, Terminal	A/R	
39	4460301	Marker, Terminal	1	
40	4460308	Bar, Buss (2 Position)	1	
41	4460305	Screw, Terminal	7	
42	4460306	Washer, Terminal	7	
43	4460307	Sleeve, Terminal	7	
44	4460311	Bar, Buss (5 Position)	1	
45	4460303	Block, Ground	1	
46	1700788	Decal, Relay Functions	1	
47	1700789	Decal, Relay Functions	1	
48	1700790	Decal, Relay Schematic	1	
49	4460300	Barrier, Terminal	1	
50	4460488	Clamp, Cable	5	
51	1840002	Duct (When Equipped)	11 in.	
52	4460244	Connector, Strain Relief	1	
53 to 62	Not Used			
63		Switch Options:	1	
	4360200	Switch, Toggle (Built Prior to May 1994)		
	4360202	Switch, Toggle (Built May 1994 to Present)		
64		Switch, Toggle Options:	1	
	Not Required	Built Prior to May 1994		
	4360202	Built May 1994 to Present		
65		Switch, Toggle Options:	1	
	Not Required	Built Prior to May 1994		
	4360200	Built May 1994 to Present		

**SECTION 2 TURNTABLE**

# SECTION 2 TURNTABLE

**FIGURE 2-43. GROUND CONTROL COMPONENTS INSTALLATION (MACHINES WITH VICKERS PROPORTIONAL VALVES) (CONTINUED)**

FIG & ITEM #	PART NUMBER	DESCRIPTION	QTY.	REV.
66	Not Required 4060802	Guard, Switch Options: Built Prior to May 1994 Built May 1994 to Present	7	
67	Not Required 4360141	Cover, Switch, - Red Options: Built Prior to May 1994 Built May 1994 to Present	1	
	0860548	<b>HARNES INSTALLATIONS (MACHINES WITH STANDARD CAPACITY BUILT PRIOR TO MAY 1994)</b>	Ref.	-
	0860909	<b>HARNES INSTALLATIONS (MACHINES WITH STANDARD CAPACITY BUILT MAY 1994 TO PRESENT)</b>	Ref.	-
	0860712	<b>HARNES INSTALLATIONS (MACHINES WITH 750 LBS. CAPACITY BUILT PRIOR TO MAY 1994)</b>	Ref.	-
	0860923	<b>HARNES INSTALLATIONS (MACHINES WITH 750 LBS. CAPACITY BUILT MAY 1994 TO PRESENT)</b>	Ref.	-
101	Not Used			
102	Not Used			
103	4920845	Harness - Box to Engine	1	
104	4920842	Harness - Box to Valves	1	
105		Ground Control Box Assembly Options (See Items 1-67 for Breakdown): Machines with Standard Capacity Options: 0237855 Box Assembly (Prior to May 1994) 0860908 Box Assembly (May 1994 to Present) Machines with 750 Lbs. Capacity Options: 0251659 Box Assembly (Prior to May 1994) 0860924 Box Assembly (May 1994 to Present)	1	
108	1060016 Not Required	Cable, Electrical - 16/3 to Limit Switches Options: Machines with Standard Capacity Machines with 750 Lbs. Capacity	A/R 12 ft. 0	
	0238045	<b>GROUND CONTROL INSTALLATIONS - STANDARD MACHINES (PRIOR TO MARCH 1991)</b>	Ref.	
	0239215	<b>GROUND CONTROL INSTALLATIONS - STANDARD MACHINES (MARCH 1991 TO PRESENT)</b>	Ref.	F
	0251677	<b>GROUND CONTROL INSTALLATIONS - 750 LBS MACHINES</b>	Ref.	F
201	Not Used			
202	1780184 1780234	Door Options: Door - 14"W x 20 1/2"H (Prior to March 1991) Door - 17 5/8"W x 22 1/2"H (March 1991 to Present)	1	
203	2940042	Latch	1	
204	3380309	Panel, Gauge	1	
205	3300182	Nut, Retainer	3	
206	2420091	Volt Meter	1	
207	4751400	Flatwasher 1/4"	10	

# SECTION 2 TURNTABLE

**FIGURE 2-43. GROUND CONTROL COMPONENTS INSTALLATION (MACHINES WITH VICKERS PROPORTIONAL VALVES) (CONTINUED)**

FIG & ITEM #	PART NUMBER	DESCRIPTION	QTY.	REV.
208	2420009	Hourmeter	1	
209	0641408	Bolt 1/4"-20NC x 1"	6	
210	4761400	Lockwasher 1/4"	16	
211	3311401	Nut 1/4"-20NC	13	
212	4300031	Stud (Welded on Part)	5	
213	2600094	Hinge	1	
214	0100011	Loctite #242 (Not Shown)	A/R	
		<b>Gauges Installation (From Engine Installation) (Variable Parts)</b>	Ref.	
271		Oil Pressure Gauge Options:	1	
	2420030	Deutz Powered Machines		
	2420035	Ford Powered Machines - Prior to August 1994 and February 1995 to Present		
	2420164	Ford Powered Machines - August 1994 to February 1995		
	Consult Factory	Wisconsin Powered Machines		
272	2420001	Fitting, Swivel	1	
273	2200261	Fitting, Coupling	1	
274		Hose Options:	A/R	
	Consult Factory	Ford and Deutz Powered Machines		
	2750527	Wisconsin Powered Machines		
275		Temperature Gauge Options:	A/R	
	Not Required	Deutz Powered Machines		
	2420019	Ford Powered Machines - Prior to August 1994 and February 1995 to Present		
	2420159	Ford Powered Machines - August 1994 to February 1995		
	Not Required	Wisconsin Powered Machines		

**SECTION 2 TURNTABLE**



# SECTION 2 TURNTABLE

FIGURE 2-43. GROUND CONTROL COMPONENTS INSTALLATION (MACHINES WITH VICKERS PROPORTIONAL VALVES) (CONTINUED)

FIG & ITEM #	PART NUMBER	DESCRIPTION	QTY.	REV.

**S  
E  
C  
T  
I  
O  
N  
  
2  
  
T  
U  
R  
N  
T  
A  
B  
L  
E**

# SECTION 2 TURNTABLE

FIGURE 2-44. GROUND CONTROL COMPONENTS INSTALLATION (MACHINES WITH HYDRAULIC CONTROLS)

SECTION 2 TURNTABLE

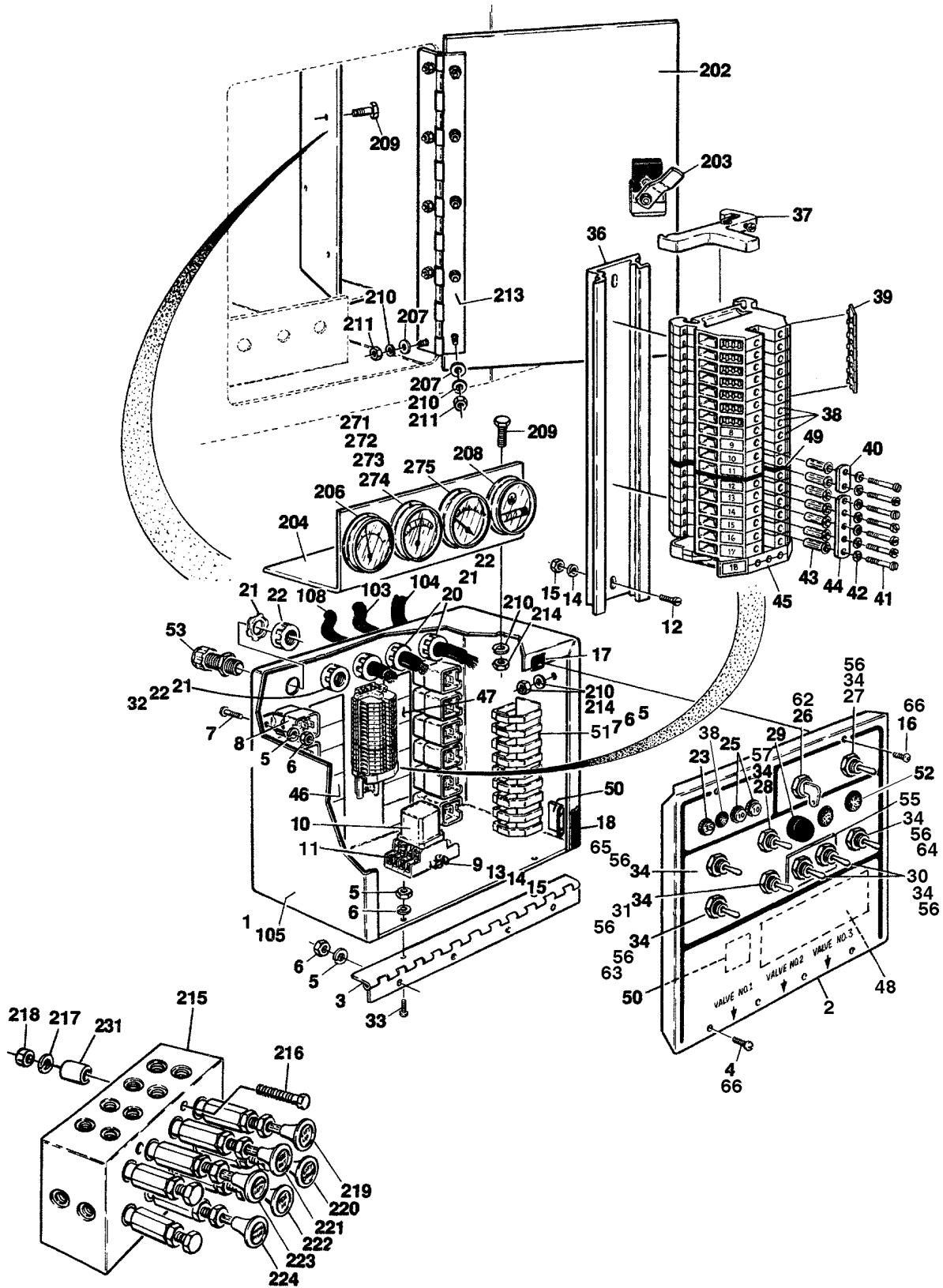

# SECTION 2 TURNTABLE

**FIGURE 2-44. GROUND CONTROL COMPONENTS INSTALLATION (MACHINES WITH HYDRAULIC CONTROLS)**

FIG & ITEM #	PART NUMBER	DESCRIPTION	QTY.	REV.
		<b>GROUND CONTROL BOX ASSEMBLIES:</b>	Ref.	
	0239219	<b>GROUND CONTROL BOX ASSEMBLY - MACHINES BUILT PRIOR TO MAY 1994</b>	Ref.	D
	0860913	<b>GROUND CONTROL BOX ASSEMBLY - MACHINES BUILT MAY 1994 TO PRESENT</b>	Ref.	B
1	0860547	Box	1	
2		Lid Options:	1	
	3251650	Machines Built Prior to May 1994		
	3252343	Machines Built May 1994 to Present		
2	Not Used			
3	2600093	Hinge	1	
4	3911006	Screw, Round Head #10-24NC x 3/8"	4	
5	4761000	Lockwasher #10	19	
6	3311001	Nut #10-24NC	22	
7	3911008	Screw, Round Head #10-24NC x 1/2"	12	
8	3740049	Relay - SPDT	12	
9	4751000	Flatwasher #10	2	
10	3740016	Relay - 3PDT	1	
11	4120002	Socket, Relay	1	
12	3910606	Screw, Round Head #6-32NC x 3/8"	2	
13	3910610	Screw, Round Head #6-32NC x 5/8"	A/R	
14	4760600	Lockwasher #6	A/R	
15	3310601	Nut #6-32NC	A	
16	0750806	Screw #8 x 3/4"	2	
17	3300177	Nut, Tinnerman	2	
18	4420037	Strip, Rubber	33 in.	
19	0100001	Adhesive (Not Shown)	A/R	
20	4460051	Connector, Strain Relief	2	
21	3300048	Nut, Conduit	4	
22	0960238	Bushing	4	
23	4360186	Breaker, Circuit - 35 Amp	1	
24	Not Used			
25	4360069	Breaker, Circuit - 10 Amp	2	
26		Switch, Key Options:	1	
	4360003	Prior to S/N 48804		
	4360466	S/N 48804 to Present		
		Key, Replacement Options:	1	
	2860002	Prior to S/N 48804		
	2860030	S/N 48804 to Present	1	
	4070991	Shim .125 (S/N 48804 to Present Only)	A/R	
	4070987	Shim .015 (S/N 48804 to Present Only)	A/R	
27		Switch, Toggle Options:	1	
	4360073	Machines Built Prior to May 1994		
	4360201	Machines Built May 1994 to Present		
28	4360199	Switch, Toggle	1	
29	4360274	Switch, Push Button	1	
30	4360202	Switch, Toggle	1	

# SECTION 2 TURNTABLE

**FIGURE 2-44. GROUND CONTROL COMPONENTS INSTALLATION (MACHINES WITH HYDRAULIC CONTROLS) (CONTINUED)**

FIG & ITEM #	PART NUMBER	DESCRIPTION	QTY.	REV.
31		Switch, Toggle Options:	1	
	4360200	Machines Built Prior to May 1994		
	4360202	Machines Built May 1994 to Present		
32	4460071	Connector, Strain Relief	2	
33	3911016	Screw, Round Head #10-24NC x 1"	3	
34	3790012	O-Ring	6	
35		Plug, Hole Options:	1	
	Not Required	Machines Built Prior to May 1994		
	3520026	Machines Built May 1994 to Present		
36	3640492	Rail (Prior to May 1995)	6 in.	
	3640555	Rail (May 1995 to Present)	1	
37	4460299	Stop, Terminal	1	
38	4460298	Strip, Terminal	A/R	
39	4460301	Marker, Terminal	1	
40	4460308	Bar, Buss (2 Position)	1	
41	4460305	Screw, Terminal	7	
42	4460306	Washer, Terminal	7	
43	4460307	Sleeve, Terminal	7	
44	4460311	Bar, Buss (5 Position)	1	
45	4460303	Block, Ground	1	
46	1700788	Decal, Relay Functions	1	
47	1700789	Decal, Relay Functions	1	
48		Decal, Relay Schematic	1	
	1700790	Machines Built Prior to May 1994		
	Not Required	Machines Built May 1994 to Present		
49	4460300	Barrier, Terminal	A/R	
50	4460488	Clamp, Cable	5	
51		Duct Options:	11in.	
	1840002	Machines Built Prior to May 1994		
	Not Required	Machines Built May 1994 to Present		
52	3520028	Plug	A/R	
53	4460244	Connector	1	
54	Not Used			
55		Nameplate - Rotate & Level Options:	1	
	3251880	Machines Built Prior to May 1994		
	Not Required	Machines Built May 1994 to Present		
56		Guard, Switch Options:	4	
	Not Required	Machines Built Prior to May 1994		
	4060802	Machines Built May 1994 to Present		
57		Cover, Red Switch Options:	1	
	Not Required	Machines Built Prior to May 1994		
	4360141	Machines Built May 1994 to Present		
58 to 61	Not Used			
62		Screw #8-32NC x 1/4 Options:	1	
	Not Required	Machines Built Prior to May 1994		
	3910804	Machines Built May 1994 to Present		
63		Switch, Toggle Options:	1	
	Not Required	Machines Built Prior to May 1994		
	4360202	Machines Built May 1994 to Present		

**SECTION 2 TURNTABLE**

# SECTION 2 TURNTABLE

**FIGURE 2-44. GROUND CONTROL COMPONENTS INSTALLATION (MACHINES WITH HYDRAULIC CONTROLS) (CONTINUED)**

FIG & ITEM #	PART NUMBER	DESCRIPTION	QTY.	REV.
64		Hardware Options:	A/R	
	3520028	Plug (Machines Built Prior to May 1994)	1	
	4360202	Switch, Toggle (Machines Built May 1994 to Present)	1	
65		Switch, Toggle Options:	1	
	Not Required	Machines Built Prior to May 1994		
	4360202	Machines Built May 1994 to Present		
66		Washer, Nylon Options:	6	
	Not Required	Machines Built Prior to May 1994		
	4740120	Machines Built May 1994 to Present		
		<b>HARNES INSTALLATIONS</b>	Ref.	-
101	Not Used			
102	Not Used			
103	4920845	Harness - Box to Engine	1	
104	4921131	Harness - Box to Valves	1	
105	0239219	Ground Control Box Assembly Options (See Items 1-72 for Breakdown):	1	
	0239219	Box Assembly (Prior to May 1994)		
	0860913	Box Assembly (May 1994 to Present)		
106	Not Used			
107	Not Used			
108	1060016	Cable, Electrical - 16/3 to Limit Switches	12 ft.	
	0239214	<b>GROUND CONTROL INSTALLATION</b>	Ref.	I
201	Not Used			
202	1780234	Door	1	
203	2940042	Latch	1	
204	3380309	Panel, Gauge	1	
205	0100011	Loctite #242 (Not Shown)	A/R	
206	2420091	Volt Meter	1	
207	4751400	Flatwasher 1/4"	10	
208	2420009	Hourmeter	1	
209	0641406	Bolt 1/4"-20NC x 3/4"	6	
210	4761400	Lockwasher 1/4"	16	
211	3311401	Nut 1/4"-20NC	13	
212	4300031	Stud (Welded on part)	5	
213	2600094	Hinge	1	
214	3300182	Nut, Retainer	3	
215	4640558	Valve Assembly - Ground Control	1	
	7009353	Cartridge (With Knob)	6	
	7009354	Cartridge (Without Knob)	2	
216	0641538	Bolt 5/16"-18NC x 4 3/4"	4	
217	4761500	Lockwasher 5/16"	4	
218	3311501	Nut 5/16"-18NC	4	
219	3251868	Decal - Lift Up	1	
220	3251869	Decal - Lift Down	1	

**SECTION 2 TURNTABLE**

# SECTION 2 TURNTABLE

**FIGURE 2-44. GROUND CONTROL COMPONENTS INSTALLATION (MACHINES WITH HYDRAULIC CONTROLS) (CONTINUED)**

FIG & ITEM #	PART NUMBER	DESCRIPTION	QTY.	REV.
221	3251867	Decal - Tele Out	1	
222	3251866	Decal - Tele In	1	
223	3251864	Decal - Swivel Left	1	
224	3251865	Decal - Swivel Right	1	
225 to 230	Not Used			
231	4563996	Tube, Spacer	4	
<b>GAUGES INSTALLATION (FROM ENGINE INSTALLATION) (VARIABLE PARTS)</b>			Ref.	
271		Oil Pressure Gauge Options:	1	
	2420030	Deutz Powered Machines		
	2420035	Ford Powered Machines - Prior to August 1994 and February 1995 to Present		
	2420164	Ford Powered Machines - August 1994 to February 1995		
	Consult Factory	Wisconsin Powered Machines		
272	2420001	Fitting, Swivel	1	
273	2200261	Fitting, Coupling	1	
274		Hose Options:	A/R	
	Consult Factory	Ford and Deutz Powered Machines		
	2750527	Wisconsin Powered Machines		
275		Temperature Gauge Options:	A/R	
	Not Required	Deutz Powered Machines		
	2420019	Ford Powered Machines - Prior to August 1994 and February 1995 to Present		
	2420159	Ford Powered Machines - August 1994 to February 1995		
	Not Required	Wisconsin Powered Machines		

**SECTION 2 TURNTABLE**

# SECTION 2 TURNTABLE

FIGURE 2-44. GROUND CONTROL COMPONENTS INSTALLATION (MACHINES WITH HYDRAULIC CONTROLS) (CONTINUED)

FIG & ITEM #	PART NUMBER	DESCRIPTION	QTY.	REV.

**S  
E  
C  
T  
I  
O  
N  
  
2  
  
T  
U  
R  
N  
T  
A  
B  
L  
E**

# SECTION 2 TURNTABLE

FIGURE 2-45. ELECTRICAL COMPONENTS INSTALLATION (TURNTABLE MOUNTED)

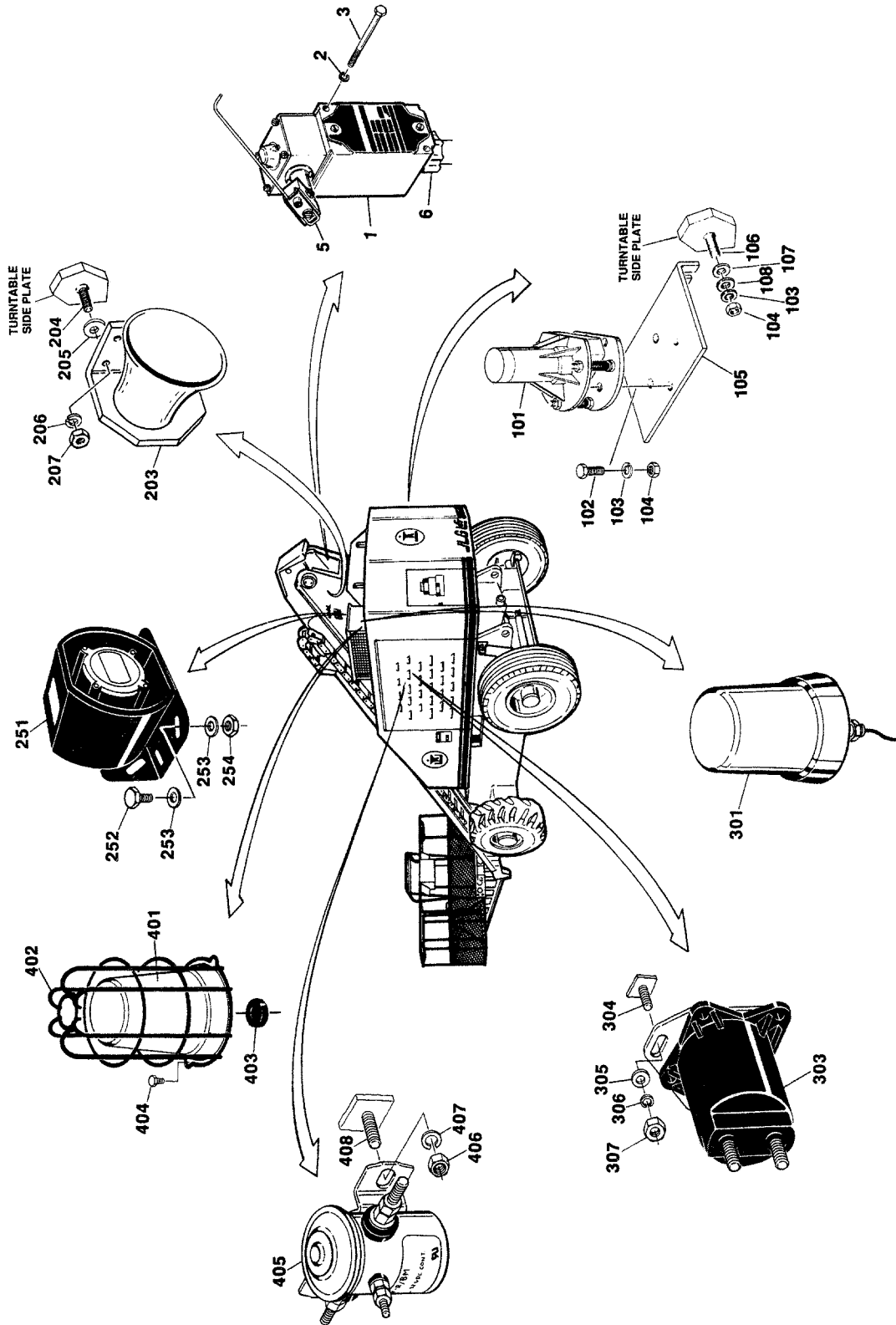



# SECTION 2 TURNTABLE

**FIGURE 2-45. ELECTRICAL COMPONENTS INSTALLATION (TURNTABLE MOUNTED)**

FIG & ITEM #	PART NUMBER	DESCRIPTION	QTY.	REV.
		<b>ELECTRICAL COMPONENTS INSTALLATION (TURNTABLE MOUNTED)</b>	Ref.	
	0236629	<b>HORIZONTAL CUTOUT LIMIT SWITCH INSTALLATION (STANDARD)</b>	Ref.	4
1	4360057	Switch, Limit	1	
2	4761000	Lockwasher #10	2	
3	0721014	Bolt #10-24NC x 1 3/4"	2	
4	Not Used			
5	0200048	Arm, Actuator	1	
6	4460049	Connector, Strain Relief	1	
	0236632	<b>TILT INDICATOR INSTALLATION (STANDARD - PRIOR TO JULY 1989)</b>	Ref.	-
	0238734	<b>TILT INDICATOR INSTALLATION (STANDARD - JULY 1989 TO PRESENT)</b>	Ref.	C
101	4360171	Indicator, Tilt	1	
102		Hardware Options:	A/R	
	0641406	Bolt 1/4"-20NC x 3/4" (Prior to July 1989)	4	
	4350106	Stud, Grooved (July 1989 to Present)	2	
103	4761400	Lockwasher 1/4" (Prior to July 1989)	6	
104	3311401	Nut 1/4"-20NC (Prior to July 1989)	6	
105	3508393	Plate, Mounting (Prior to July 1989)	1	
106	4300032	Stud (Welded on Part) (Prior to July 1989)	2	
107	4751500	Flatwasher 5/16" (Prior to July 1989)	2	
108	4751400	Flatwasher 1/4" (Prior to July 1989)	2	
		<b>ALARMS INSTALLATION (OPTIONAL ON STANDARD MACHINES BUILT PRIOR TO APRIL 1992)</b>	Ref.	
	0237054	<b>BACK-UP ALARM</b>	Ref.	B
	0237056	<b>DESCENT ALARM</b>	Ref.	B
	0239055	<b>MOTION ALARM</b>	Ref.	A
	0237055	<b>TILT ALARM</b>	Ref.	B
	0237012	<b>TRAVEL ALARM</b>	Ref.	A
201	Not Used			
202	Not Used			
203		Alarm Options:	1	
	See Note	Alarm (Used Prior to July 1989)		
	0140024	Alarm (Used July 1989 to April 1992)		
		<b>Note: Use 0140024 Alarm in place of original equipment 0140012 Alarm (No cover required with 0140024 alarm)</b>		
	0140024	Alarm (July 1989 to April 1992)		
204	4300031	Stud (Welded on Part)	4	
205	4751400	Flatwasher 1/4"	4	
206	4761400	Lockwasher 1/4"	4	

**SECTION 2 TURNTABLE**

# SECTION 2 TURNTABLE

**FIGURE 2-45. ELECTRICAL COMPONENTS INSTALLATION (TURNTABLE MOUNTED)**

FIG & ITEM #	PART NUMBER	DESCRIPTION	QTY.	REV.
207	3311401	Nut 1/4"-20NC	4	
	0251543	<b>ALARMS INSTALLATION (OPTIONAL ON STANDARD MACHINES BUILT APRIL 1992 TO PRESENT)</b>	Ref.	B
	0250122	<b>ALARMS INSTALLATION (U/L LISTED MACHINES)</b>	Ref.	A
251		Alarm Options:	1	
	0140032	Standard Machines		
	0140025	U/L Listed Machines (Prior to September 1995)		
	0140024	U/L Listed Machines (September 1995 to Present)		
252	0641406	Bolt 1/4"-20NC x 3/4"	2	
253	4751400	Flatwasher 1/4"	4	
254	3311405	Locknut 1/4"-20NC	2	
	0237010	<b>BEACON LIGHT INSTALLATION - AMBER (OPTIONAL)</b>	Ref.	B
	0237011	<b>BEACON LIGHT INSTALLATION - RED (OPTIONAL)</b>	Ref.	B
	0254186	<b>BEACON LIGHT INSTALLATION - DUAL (OPTIONAL)</b>	Ref.	-
301		Beacon Light Options:	A/R	
	2920018	Amber (Single)	1	
	2920018	Amber (Dual)	2	
	2920019	Red (Single)	1	
302		Bracket Options (Not Shown)	A/R	
	Not Required	(Single Beacons)		
	0901973	(Dual Beacons)	1	
303	3740067	Relay	1	
304	4300031	Stud (Welded on Part)	1	
305	4751400	Flatwasher 1/4"	2	
306	4761400	Lockwasher 1/4"	2	
307	3311401	Nut 1/4"-20NC	2	
	0250584	<b>STROBE LIGHT INSTALLATIONS (OPTIONAL ON MACHINES BUILT PRIOR TO FEBRUARY 1994)</b>	Ref.	-
	0254457/ 0254699	<b>STROBE LIGHT INSTALLATIONS (OPTIONAL ON MACHINES BUILT FEBRUARY 1994 TO PRESENT)</b>	Ref.	-/-
401		Strobe Light Options:	1	
	2920081	Amber (Machines Built Prior to February 1994)		
	2920105	Amber (Machines February 1994 to Present)		
	2920109	Red (Machines February 1994 to Present)		
402		Guard, Light Options:	1	
	2920082	Machines Built Prior to February 1994		
	4060829	Machines February 1994 to Present		
403		Grommet Options:	1	
	Not Required	Machines Built Prior to February 1994		
	2540016	Machines February 1994 to Present		

**SECTION 2 TURNTABLE**

# SECTION 2 TURNTABLE

**FIGURE 2-45. ELECTRICAL COMPONENTS INSTALLATION (TURNTABLE MOUNTED)**

FIG & ITEM #	PART NUMBER	DESCRIPTION	QTY.	REV.
404	Not Required	Screw, Self-Tapping 1/4" x 1/2" Options: Machines Built Prior to February 1994	4	
	3941404	Machines February 1994 to Present		
405	3740002	Relay (Machines Built Prior to February 1994)	1	
406	3311401	Nut 1/4"-20NC (Machines Built Prior to February 1994)	2	
407	4761400	Lockwasher (Machines Built Prior to February 1994)	2	
408	4300031	Stud (Welded on Part) (Machines Built Prior to February 1994)	2	

SECTION 2 TURNTABLE

# SECTION 2 TURNTABLE

FIGURE 2-46. HOODS INSTALLATION (MACHINES BUILT PRIOR TO DECEMBER 1992)

SECTION 2 TURNTABLE

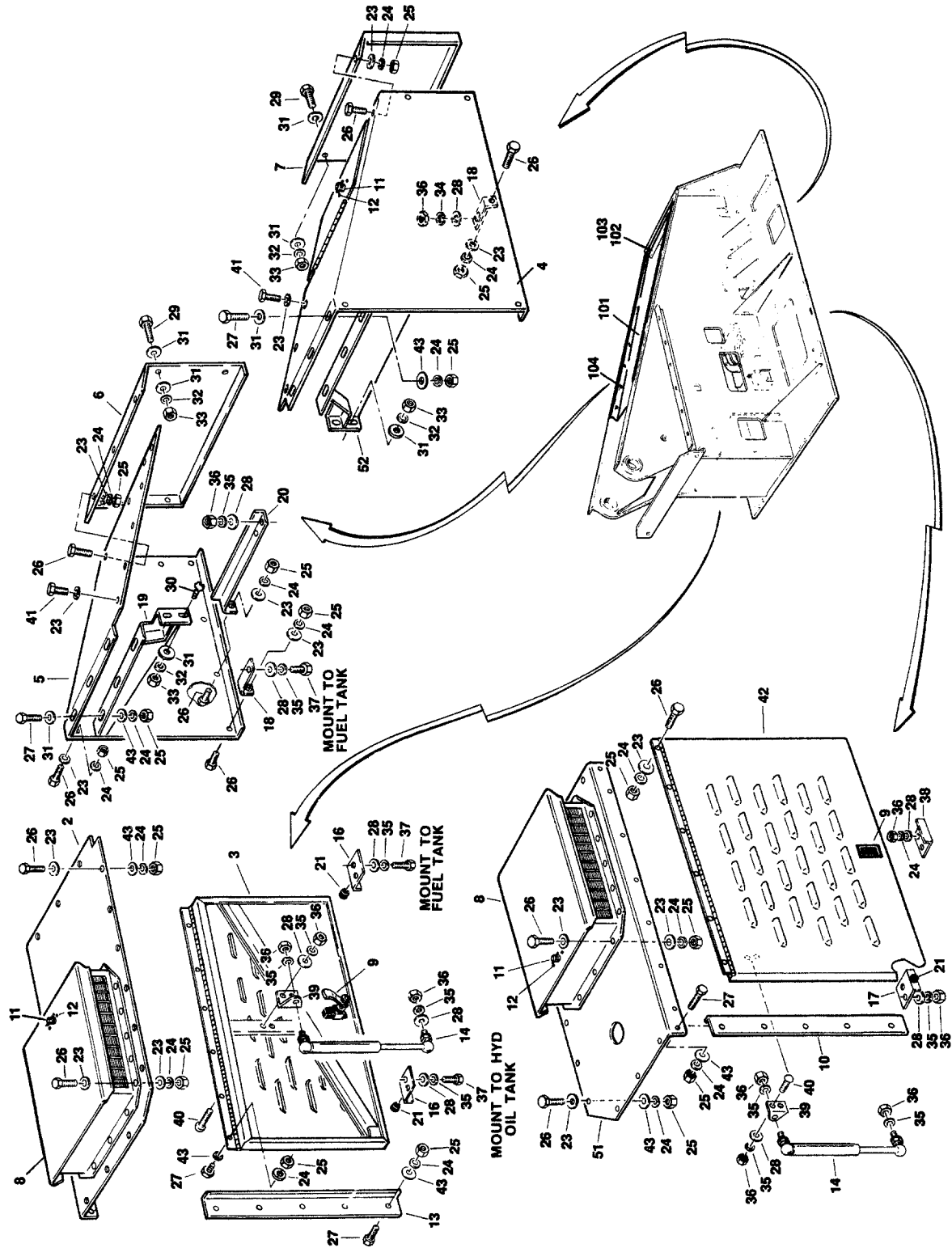

# SECTION 2 TURNTABLE

**FIGURE 2-46. HOODS INSTALLATION (MACHINES BUILT PRIOR TO DECEMBER 1992)**

FIG & ITEM #	PART NUMBER	DESCRIPTION	QTY.	REV.
		<b>HOODS INSTALLATIONS (MACHINES BUILT PRIOR TO DECEMBER 1992)</b>	Ref.	
	1280640	<b>HOODS INSTALLATION (STANDARD PARTS)</b> <b>Note: Replacement Decals Must Be Ordered Separately - See Section 8.</b>	Ref. Ref.	K
1	Not Used			
2		Panel - Top Hood (Tank Side) Options: Panel with 12 Bolt Holes on Top (Prior to May 1987)	1	
	1780152	Panel with 16 Bolt Holes on Top (May 1987 to December 1992)		
	1780219	Door (Tank Side)	1	
3	4842227	Hood (Engine Side)	1	
4	4841974	Hood (Tank Side) Options: Hood with Welded-on Steel Manual Storage Box (Prior to July 1987)	1	
5	4841983	Hood with Welded-on Steel Manual Storage Box (July 1987 to December 1992)		
	1780174	Panel - End (Tank Side) Options: Panel (Prior to September 1992)	1	
6	1780147	Panel (September 1992 to December 1992)		
	4844252	Panel - End (Engine Side)	1	
7	1780148	Ventilator Weldment	2	
8	4842979	Latch	2	
9	2940042	Panel - Filler (Engine Side)	1	
10	1780171	Latch	3	
11	2940050	Rivet	6	
12	3820012	Panel - Filler (Tank Side)	1	
13	1780172	Gas Spring Assembly	2	
14	4160081	Not Used		
15	Not Used	Bracket, Door Stop (Tank Side)	2	
16	0901197	Bracket, Door Stop (Engine Side)	2	
17	0901198	Bracket, Hood Mounting	4	
18	0901199	Bracket, Hood Support - Top (Tank side)	1	
19	4842052	Bracket, Hood Support - Bottom (Tank Side)	2	
20	0901188	Bumper, Door	4	
21	0940036	Not Used		
22	Not Used	Flatwasher 1/4"	92	
23	4751400	Lockwasher 1/4"	126	
24	4761400	Locknut 1/4"-20NC (Item 24 not required when Locknuts are used)	94	
25	3311405	Bolt 1/4"-20NC x 3/4"	78	
26	0641406	Bolt 1/4"-20NC x 1"	16	
27	0641408	Flatwasher 5/16"	19	
28	4751500	Bolt 3/8"-16NC x 1 1/4"	4	
29	0641610	Stud (Welded on Part)	4	
30	4300034	Flatwasher 3/8"	12	
31	4751600	Lockwasher 3/8"	4	
32	4761600			

# SECTION 2 TURNTABLE

**FIGURE 2-46. HOODS INSTALLATION (MACHINES BUILT PRIOR TO DECEMBER 1992)**

FIG & ITEM #	PART NUMBER	DESCRIPTION	QTY.	REV.
33	3311605	Locknut 3/8"-16NC (Item 32 not required when Locknuts are used)	8	
34	4300038	Stud (Welded on Part)	13	
35	4761500	Lockwasher 5/16"	6	
36	3311505	Locknut 5/16"-18NC (Items 35 not required when Locknuts are used)	20	
37	0641508	Bolt 5/16"-18NC x 1"	5	
38	0901235	Bracket, Door Latch (Engine Side)	1	
39	3200222	Bracket, Mounting - Gas Spring	2	
40	0630383	Bolt, Carriage 5/16"-18NC x 3/4"	4	
41	3941406	Screw, Self-Tapping 1/4" x 3/4"	8	
42	4842694	Door (Engine Side)	1	
43	4740362	Washer, Fender	34	
44	0100011	Loctite #242 (Not Shown)	A/R	
	0237474	<b>HOODS INSTALLATION - DEUTZ POWERED MACHINES (VARIABLE PARTS)</b>	Ref.	F
	0236307	<b>HOODS INSTALLATION - FORD POWERED MACHINES (VARIABLE PARTS)</b>	Ref.	M
	0239138	<b>HOODS INSTALLATION - WISCONSIN POWERED MACHINES</b>	Ref.	D
51		Panel - Hood Top (Engine Side) Options:	1	
		Deutz Powered Machines		
	1780205	Panel (Prior to November 1989)		
	1780239	Panel (November 1989 to December 1992)		
		Ford Powered Machines		
	1780151	Panel (Prior to April 1986)		
	1780204	Panel (April 1986 to November 1989)		
	1780239	Panel (November 1989 to December 1992)		
		Wisconsin Powered Machines		
	1780233	Panel (Prior to November 1989)		
	1780239	Panel (November 1989 to December 1992)		
52	4842051	Bracket, Hood Support - Top (Engine Side) Options:	1	
	4842051	Deutz Powered Machines		
		Ford Powered Machines		
	4842051	Bracket (Prior to January 1987)		
	0901418	Bracket (January 1987 to December 1992)		
	4842051	Wisconsin Powered Machines		
	0236193	<b>TURNTABLE SHIELD INSTALLATION</b>	Ref.	A
101	4060572	Shield	1	
102	0641405	Bolt 1/4"-20NC x 5/8"	5	
103	4761400	Lockwasher 1/4"	5	
104	3941405	Screw, Self-Tapping 1/4" x 5/8"	3	

**SECTION 2 TURNTABLE**

# SECTION 2 TURNTABLE

FIGURE 2-46. HOODS INSTALLATION (MACHINES BUILT PRIOR TO DECEMBER 1992)

FIG & ITEM #	PART NUMBER	DESCRIPTION	QTY.	REV.

**S  
E  
C  
T  
I  
O  
N  
  
2  
  
T  
U  
R  
N  
T  
A  
B  
L  
E**

# SECTION 2 TURNTABLE

FIGURE 2-47. HOODS INSTALLATION (MACHINES BUILT DEC. 1992 TO PRESENT)

SECTION 2 TURNTABLE

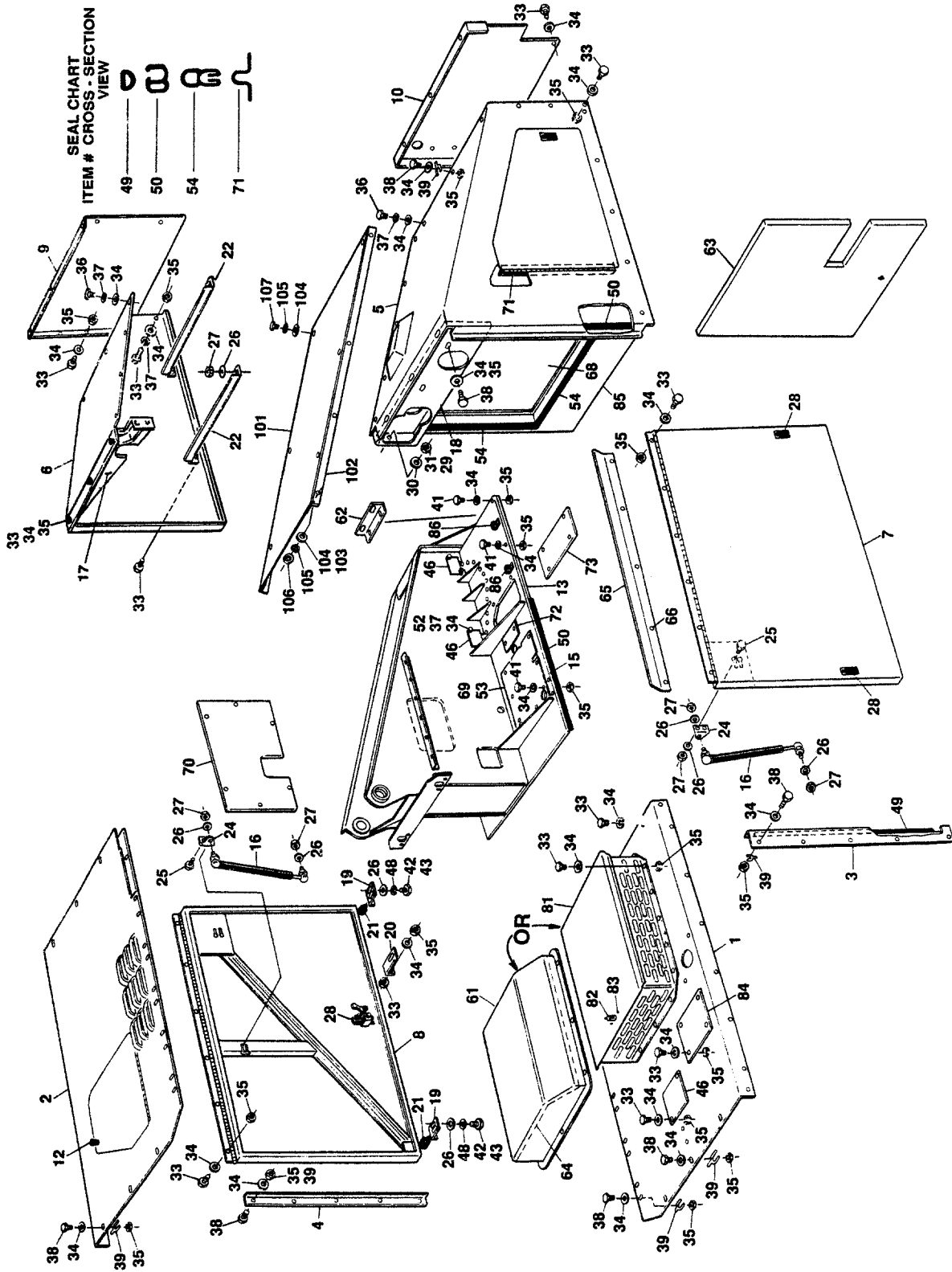



# SECTION 2 TURNTABLE

**FIGURE 2-47. HOODS INSTALLATION (MACHINES BUILT DEC. 1992 TO PRESENT)**

FIG & ITEM #	PART NUMBER	DESCRIPTION	QTY.	REV.
		<b>HOODS INSTALLATION (MACHINES BUILT DECEMBER 1992 TO PRESENT)</b>	Ref.	
		<b>HOODS INSTALLATION (STANDARD PARTS)</b>	Ref.	
		<b>Note: Replacement Decals Must Be Ordered Separately - See Section 8.</b>	Ref.	
1	1780270	Panel - Hood Top (Engine Side)	1	
2	4844391	Panel - Hood Top (Valve Side)	1	
3	1780271	Panel - Filler (Engine Side)	1	
4	1780172	Panel - Filler (Valve Side)	1	
5	4844180	Hood (Engine Side)	1	
6		Hood (Tank Side) Options:	1	
	1780174	Prior to May 1995		
	3380418	May 1995 to Present		
7	4844074	Door (Engine Side)	1	
8	4844113	Door (Tank Side)	1	
9	4844252	Panel, End (Valve Side)	1	
10	1780148	Panel, End (Engine Side)	1	
11	Not Used			
12	2940051	Latch	1	
13	0901850	Bracket, Hood	1	
14	Not Used			
15	3536088	Plate, Stop	1	
16	4160081	Gas Spring	2	
17	4842052	Bracket, Support - Top (Tank Side)	1	
18	4844234	Bracket, Support - Top (Tank Side)	1	
19	0901197	Bracket, Door Stop	2	
20	0901199	Bracket, Hood Mounting	1	
21	0940036	Bumper, Door	2	
22	0901188	Bracket, Support - Bottom (Tank Side)	1	
23	Not Used			
24	3200222	Bracket, Gas Spring Mounting	2	
25	0630383	Bolt, Carriage 5/16"-18NC x 3/4"	4	
26	4751500	Flatwasher 5/16"	A/R	
27	3311505	Locknut 5/16"-18NC	8	
28	2940042	Latch	4	
29	4300034	Stud (Welded on Part)	4	
30	4751600	Flatwasher 3/8"	12	
31	3311605	Locknut 3/8"-16NC	8	
32	4300038	Stud (Welded on Part)	4	
33	0641406	Bolt 1/4"-20NC x 3/4"	48	
34	4751400	Flatwasher 1/4"	A/R	
35	3311405	Locknut 1/4"-20NC	A/R	
36	3941406	Screw, Self-tapping 1/4" x 3/4"	10	
37	4761400	Lockwasher 1/4"	A/R	
38	0641408	Bolt 1/4"-20NC x 1"	A/R	
39	4740362	Washer, Fender	34	
40	0641610	Bolt 3/8"-16NC x 1 1/4"	4	

# SECTION 2 TURNTABLE

**FIGURE 2-47. HOODS INSTALLATION (MACHINES BUILT DEC. 1992 TO PRESENT) (CONTINUED)**

FIG & ITEM #	PART NUMBER	DESCRIPTION	QTY.	REV.
41	0641412	Bolt 1/4"-20NC x 1 1/2"	A/R	
42	0641508	Bolt 5/16"-18NC x 1"	5	
43	0100011	Loctite #242 (Not Shown)	A/R	
44 to 45	Not Used			
46	1670321	Cover	A/R	
47	Not Used			
48	4761500	Lockwasher	5	
49	3960433	Seal	69 in.	
50	3960418	Seal	A/R	
51	Not Used			
52	3311401	Nut 1/4"-20NC	A/R	
53	1670644	Cover, Base Plate	1	
54	3960389	Seal	A/R	
55	4060803	Shield, Trim Lock (Not Shown - Located on Turntable)	2ft	
	0253371	<b>HOODS INSTALLATION - DEUTZ POWERED MACHINES (VARIABLE PARTS)</b>	Ref.	E
61	4844236	Duct Weldment	1	
62	3536282	Panel, Filler	1	
63	2820056	Foam, Acoustical	1	
64	2820057	Foam, Acoustical	1	
65	3535951	Plate, Shield	1	
66	3820018	Rivet	5	
67	2820053	Foam, Acoustical	1	
68	2820058	Foam, Acoustical	1	
69	Not Used			
70	1670658	Cover, Side Sheet	1	
71	3960429	Seal (With Self-Stick Tape)	21 in.	
72	1670657	Cover	1	
73	1670668	Cover, Base Plate	1	
74	4060803	Shield, Trim Lock (Not Shown - Located on Turntable)	2ft	
	0253373	<b>HOODS INSTALLATION - FORD POWERED MACHINES (VARIABLE PARTS)</b>	Ref.	E
81	4680015	Ventilator	1	
82	2940050	Latch	1	
83	3820012	Rivet	2	
84	1670656	Cover, Hood	1	
85	4844323	Baffle	1	
86	1320041	Clamp	1	
	0253990	<b>TURNTABLE SHIELD INSTALLATION</b>	Ref.	A
101	4060851	Shield	1	
102	0181704	Angle	2	
103	4300031	Stud (Welded on Part)	8	
104	4751400	Flatwasher 1/4"	14	
105	4761400	Lockwasher 1/4"	14	

**SECTION 2 TURNTABLE**

# SECTION 2 TURNTABLE

FIGURE 2-47. HOODS INSTALLATION (MACHINES BUILT DEC. 1992 TO PRESENT) (CONTINUED)

FIG & ITEM #	PART NUMBER	DESCRIPTION	QTY.	REV.
106	3311401	Nut 1/4"-20NC	8	
107	3941405	Screw, Self-Tapping 1/4" x 5/8"	6	

**S  
E  
C  
T  
I  
O  
N  
  
2  
  
T  
U  
R  
N  
T  
A  
B  
L  
E**

# SECTION 2 TURNTABLE

FIGURE 2-47. HOODS INSTALLATION (MACHINES BUILT DEC. 1992 TO PRESENT) (CONTINUED)

FIG & ITEM #	PART NUMBER	DESCRIPTION	QTY.	REV.

**S  
E  
C  
T  
I  
O  
N  
  
2  
  
T  
U  
R  
N  
T  
A  
B  
L  
E**

# SECTION 3 BOOM

TABLE OF CONTENTS		
FIGURE	DESCRIPTION	PAGE
3-1	BOOM COMPONENT ASSEMBLIES.....	3-2
3-2	BOOM WIPERS INSTALLATION .....	3-10
3-3	EXTEND-A-REACH INSTALLATIONS (60H+6 Machines) .....	3-12

**S  
E  
C  
T  
I  
O  
N  
  
3  
  
B  
O  
O  
M**

# SECTION 3 BOOM

## FIGURE 3-1. BOOM COMPONENT ASSEMBLIES

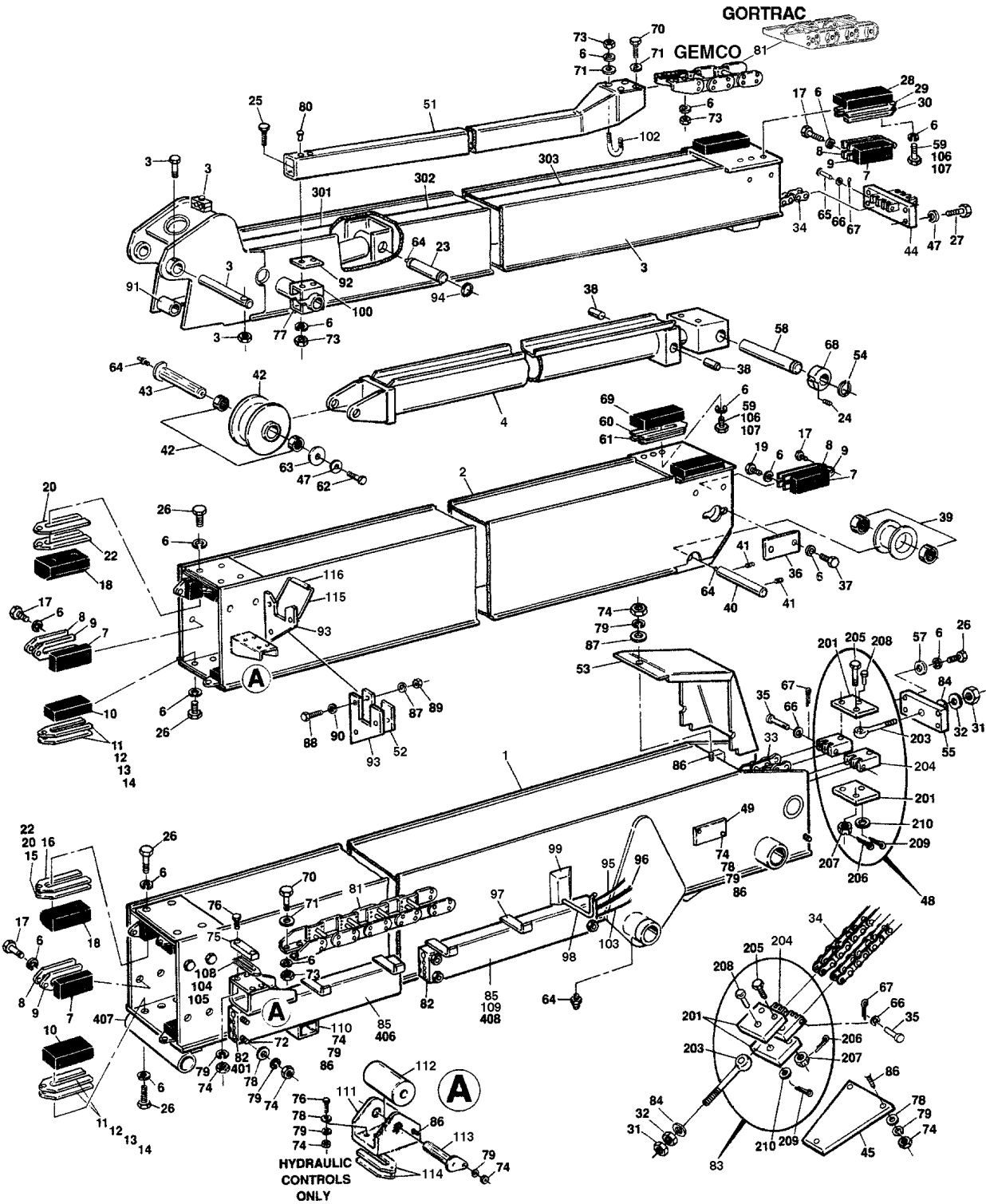

# SECTION 3 BOOM

**FIGURE 3-1. BOOM COMPONENT ASSEMBLIES**

FIG & ITEM #	PART NUMBER	DESCRIPTION	QTY.	REV.
		<b>BOOM COMPONENT ASSEMBLIES</b>	Ref.	
	0800392	<b>BOOM ASSEMBLY - 60H WITH STANDARD CONTROL</b>	Ref.	27
	0800577	<b>BOOM ASSEMBLY - 60H WITH HYDRAULIC CONTROL</b>	Ref.	12
	0800505	<b>BOOM ASSEMBLY - 60H+6 WITH STANDARD CONTROL</b>	Ref.	9
	0800418	<b>BOOM ASSEMBLY - 70H WITH STANDARD CONTROL</b>	Ref.	21
	0800631	<b>BOOM ASSEMBLY - 70H WITH HYDRAULIC CONTROL</b>	Ref.	13
1		Boom Base Weldment Options:	A/R	
	0800391	60H/60H+6	1	
	0960985	Bushing	2	
	0800421	70H	1	
	0960985	Bushing	2	
2		Boom Mid Weldment Options:	1	
	0800390	60H with Standard Control		
		60H with Hydraulic Control		
	0800390	Mid (Prior to July 1991)		
	0800744	Mid (July 1991 to Present)		
	0800390	60H+6 with Standard Control		
	0800420	70H with Standard Control		
		70H with Hydraulic Control		
	0800420	Mid (Prior to March 1992)		
	0800751	Mid (March 1992 to Present)		
3		Boom Fly Weldment Options:	1	
		60H with Standard Control		
	0800389	Fly (Prior to June 1985)		
	0800417	Fly (June 1985 to Present)		
	1320052	Clamp	1	
	3421088	Boom Pin Assembly (Includes Hardware)	1	
	0800417	60H with Hydraulic Control		
	1320052	Clamp	1	
	3421088	Boom Pin Assembly (Includes Hardware)	1	
	0800471	60H+6 with Standard Control		
	1320052	Clamp	1	
	0800419	70H with Standard Control		
	1320052	Clamp	1	
	3421088	Boom Pin Assembly (Includes Hardware)	1	
	0800419	70H with Hydraulic Control		
	1320052	Clamp	1	
4		Telescope Cylinder Assembly Options (See Section 5 for Breakdown):	1	
	1681516	60H/60H+6		
		70H Options:		
	1681574	Cylinder (Prior to December 1986)		
	1681813	Cylinder (December 1986 to Present)		

**SECTION 3 BOOM**

# SECTION 3 BOOM

**FIGURE 3-1. BOOM COMPONENT ASSEMBLIES (CONTINUED)**

FIG & ITEM #	PART NUMBER	DESCRIPTION	QTY.	REV.
5	Not Used			
6	4761600	Lockwasher 3/8"	74	
7	3340394	Pad, Wear	12	
8	4070502	Shim 1/16"	A/R	
9	4070501	Shim 1/8"	A/R	
10	3340403	Pad, Wear	4	
11	4070508	Shim 1/16"	A/R	
12	4070507	Shim 1/8"	A/R	
13	4070505	Shim 3/16"	A/R	
14	4070506	Shim 1/4"	A/R	
15	4070497	Shim 1/8"	A/R	
16	4070500	Shim 1/4"	A/R	
17	0641606	Bolt 3/8"-16NC x 3/4"	22	
18	3340399	Pad, Wear	4	
19	0641614	Bolt 3/8"-16NC x 1 3/4"	2	
20	4070499	Shim 1/32"	A/R	
21	0100019	Loctite #271	A/R	
22	4070498	Shim 1/16"	A/R	
23		Attach Pin Options:	1	
	3420424	Pin (Machines Built Prior to June 1985)		
	3421207	Pin (Machines Built June 1985 to Present)		
		<b>Note: See Extend-A-Reach Installation for 66H and 60H+6 Models.</b>		
24	3951603	Bolt, Socket Head 3/8"-16NC x 3/8" (Not Shown)	2	
25	0641644	Bolt 3/8"-16NC x 5 1/2"	2	
26	0641612	Bolt 3/8"-16NC x 1 1/2"	24	
27	0641814	Bolt 1/2"-13NC x 1 3/4"	4	
28	3340401	Pad, Wear	2	
29	4070504	Shim 1/16	2	
30	4070503	Shim 1/8"	6	
31	3312202	Nut, Jam 3/4"-10NC	2	
32	3300241	Locknut 3/4"-10NC (Grade 8)	2	
33		Chain, Extend Options:	1 set	
	1260149	60H/60H+6		
	1260176	70H		
34		Chain, Retract Options:	1 set	
	1260166	60H/60H+6		
	1260177	70H		
35	3420414	Pin, Clevis	4	
36	0360372	Bar	2	
37	0641605	Bolt 3/8"-16NC x 5/8"	4	
38	3420410	Pin, Trunion	2	
39	0237557	Sheave Assembly Options:	1	
	0961857	Bushing	2	
40	3421349	Pin, Sheave	1	
41	3951608	Setscrew 3/8"-16NC x 1"	2	
42	0237564	Telescope Sheave Assembly	1	
	0960406	Bushing	2	

SECTION 3 BOOM



# SECTION 3 BOOM

**FIGURE 3-1. BOOM COMPONENT ASSEMBLIES (CONTINUED)**

FIG & ITEM #	PART NUMBER	DESCRIPTION	QTY.	REV.
43		Telescope Sheave Pin Options:	1	
	0236298	Pin (Prior to June 1985)		
	3421348	Pin (June 1985 to Present)		
44		Chain Attach Block Options:	1	
		60H with Standard Control		
	0236295	Block (Prior to June 1985)		
	0236585	Block (June 1985 to November 1992)		
	4844156	Block (November 1992 to Present)		
		60H with Hydraulic Control		
	0236295	Block (Prior to June 1985)		
	0236585	Block (June 1985 to Present)		
		60H+6 with Standard Control		
	0236585	Block (Prior to November 1992)		
	4844156	Block (November 1992 to Present)		
		70H with Standard Control		
	0236295	Block (Prior to November 1992)		
	4844274	Block (November 1992 to Present)		
		70H with Hydraulic Control		
	0236295	Block		
45	1670335	Plate, Cover	1	
46	Not Used			
47	4761800	Lockwasher 1/2"	5	
48	0236294	Chain Adjuster Assembly (Extend Chain) (See Items 201-251 for Breakdown)	1	
49	1670321	Cover, Side (Boom Base)	2	
50	Not Used			
51		Carrier Tube Options:	1	
		60H with Standard Control		
	1180137	Tube (Prior to June 1985)		
	1180150	Tube (June 1985 to Present)		
		60H with Hydraulic Control		
	1180182	Tube (Prior to January 1992)		
	1180265	Tube (January 1992 to Present)		
	1180150	60H+6 with Standard Control		
	1180153	70H with Standard Control		
		70H with Hydraulic Control		
	1180234	Tube (Prior to June 1985)		
	1180267	Tube (June 1985 to Present)		
52		Support, Plastic Options:	1	
	4340453	Machines with Standard Control		
	4340562	Machines with Hydraulic Control		
53	4060559	Shield, Boom End	1	
54	3760233	Ring, Retainer	2	
55		Block, Chain Attach Options:	1	
	0236505	Block (Prior to June 1985)		
	0236805	Block (June 1985 to Present)		
56	Not Used			
57	4740185	Washer, Hardened	4	

**SECTION 3 BOOM**

# SECTION 3 BOOM

**FIGURE 3-1. BOOM COMPONENT ASSEMBLIES (CONTINUED)**

FIG & ITEM #	PART NUMBER	DESCRIPTION	QTY.	REV.
58		Pin Options:	1	
	3420420	Pin (Prior to June 1985)		
	3421228	Pin (June 1985 to Present)		
59	0641610	Bolt 3/8"-16NC x 1 1/4"	12	
60	4070496	Shim 1/16"	A/R	
61	4070509	Shim 1/8"	A/R	
62	0651808	Bolt 1/2"-20NF x 1"	1	
63	4740003	Washer, Hardened	1	
64	2160002	Fitting, Grease	4	
65	3421029	Pin, Clevis	2	
66	4711400	Flatwasher 1/4" Narrow	6	
67	3450203	Pin, Cotter 1/16" x 3/4"	6	
68	0960979	Bushing, Eccentric	2	
69	3340397	Pad, Wear	2	
70	0641609	Bolt 3/8"-16NC x 1 1/8"	6	
71	4751600	Flatwasher 3/8"	10	
72	4300042	Stud	6	
73	3311602	Nut, Jam 3/8"-16NC	10	
74	3311401	Nut 1/4"-20NC	19	
75		Pad, Wear Options:	1	
	3340405	Machines with Standard Control		
	Not Required	Machines with Hydraulic Control		
76	0641414	Bolt 1/4"-20NC x 1 3/4"	2	
77	1320121	Clamp, Powertrack	1	
78	4751400	Flatwasher 1/4"	14	
79	4761400	Lockwasher 1/4"	19	
80	3520029	Plug, Hole (Prior to S/N 46278)	2	
81		Carrier, Hose and Cable Options:	A/R	
		60H/60H+6 with Standard Control	1	
	Use 1001119692	Gemco Replacement Parts (was p/n 1180104):	1	
	7006130	1 Foot Section	1	
	7006133	Feet, Mounting	4	
	7006131	1 Foot Section with Mounting Feet	2	
	7006138	Pin Kit	A/R	
	7006159	Tool Kit	1	
	1001119692	Gortrac Replacement Parts:	1	
	70003147	Section Repair Kit (6 Links)	1	
	70003148	Bracket, Mounting Kit	1	
	1180181	60H with Hydraulic Control	1	
	7006165	1 Foot Section	1	
	7006143	Feet, Mounting	4	
	7006155	Rod, Spring Loaded	A/R	
	1180136	70H with Standard Control	1	
	7006130	1 Foot Section	1	
	7006133	Feet, Mounting	4	
	7006131	1 Foot Section with Mounting Feet	2	
	7006138	Pin Kit	A/R	
	7006159	Tool Kit	1	

SECTION 3 BOOM

# SECTION 3 BOOM

**FIGURE 3-1. BOOM COMPONENT ASSEMBLIES (CONTINUED)**

FIG & ITEM #	PART NUMBER	DESCRIPTION	QTY.	REV.
81 (cont'd)	1180233	70H with Hydraulic Control	1	
	7006188	1 Foot Section	1	
	7006179	Feet, Mounting	4	
	7006180	Rod, Spring Loaded	A/R	
82	4340413	Support, Hydraulic Lines (Right Side)	3	
83	Not Used	Chain Adjuster Assembly Options (See Items 201-251 for Breakdown):	1	
		60H/60H+6 with Standard Control Options:		
	0236294	Adjuster (Prior to June 1985)		
	0236044	Adjuster (June 1985 to Present)		
	0236044	60H with Hydraulic Control		
	0236294	70H with Standard/Hydraulic Control		
84	4740057	Washer, Hardened	2	
85		Shield, Electric/Hydraulic Lines (Right Side) Options:	2	
	4060568	60H/60H+6		
	4060599	70H		
86	4300031	Stud	11	
87	4751500	Flatwasher 5/16"	9	
88	0641512	Bolt 5/16"-14NC x 1 1/2"	3	
89	3311501	Nut 5/16"-14NC	3	
90	4761500	Lockwasher 5/16"	3	
		Platform Level Cylinder Options (See Section 5 for Breakdowns):	1	
91		60H/70H with Standard/Hydraulic Control Options:		
	1681518	Cylinder (Prior to June 1985)		
	1681548	Cylinder (June 1985 to December 1986)		
	1681722	Cylinder (December 1986 to November 1991)		
	1682602	Cylinder (November 1991 to Present)		
		70H with Standard/Hydraulic Control Options:		
	1682602	Cylinder (November 1991 to S/N 33111)		
	1683534	Cylinder (S/N 33111 1991 to Present)		
	Not Required	60H+6		
	92	4280242	Strip, Reinforcement	1
93		Support, Mid Boom Options:	2	
	4340468	60H/60H+6 with Standard Control Options:		
	4340561	60H with Hydraulic Control		
	4340561	70H with Standard/Hydraulic Control		
94		Ring, Retaining Options:	2	
	3760133	60H/70H with Standard/Hydraulic Control Options:		
	Not Required	60H+6		
95		Cable, Electrical Options:	A/R	
	1060229	Cable, Electrical - 16/30 Cable (60H with Standard Control)	76.5 ft.	
	1060039	Cable, Electrical - 16/24 Cable (60H with Hydraulic Control)	76.5 ft.	
	1060229	Cable, Electrical - 16/30 Cable (60H+6 with Standard Control)	88.5 ft.	
	1060229	Cable, Electrical - 16/30 Cable (70H with Standard/Hydraulic Control) (Prior to May 1992)	88.5 ft.	
	1060516	Cable, Electrical - 16/30 Cable (70H with Standard/Hydraulic Control) (May 1992 to Present)	88.5 ft.	

**SECTION 3 BOOM**

# SECTION 3 BOOM

**FIGURE 3-1. BOOM COMPONENT ASSEMBLIES (CONTINUED)**

FIG & ITEM #	PART NUMBER	DESCRIPTION	QTY.	REV.
96		Cable, Electrical - 12/4	A/R	
	1060012	60H	77.3 ft.	
	1060012	66H/60H+6	89.3 ft.	
	1060012	70H (Prior to May 1992)	89.3 ft.	
	1060515	70H (May 1992 to Present)	89.3 ft.	
97	Not Used	Support, Power Track Options:	3	
	4340514	60H/60H+6 with Standard/Hydraulic Control		
		70H with Standard/Hydraulic Control		
	4340523	Support, Power Track (12 1/2" Length)		
	4340522	Support, Power Track (9 3/4" Length)		
98	3840840	Rod, Hanger	1	
99	2660042	Holder, Rod	1	
100	1320138	Clamp, Power Track	1	
101		Cover, Boom Options (S/N 34256 to Present - Not Shown Located on Bottom of Boom):	6	
	Not Required	60H/60H+6 with Standard Control		
	Not Required	60H with Hydraulic Control		
	1670836	70H with Standard/Hydraulic Control		
102		Clamp Options:	1	
	1320072	60H/60H+6 with Standard Control		
	1320171	60H with Hydraulic Control		
	1320171	70H with Standard/Hydraulic Control		
103		Harness - 110V Options:	1	
	4920613	60H with Standard/Hydraulic Control		
	4920865	60H+6 with Standard Control		
	4920616	70H with Standard/Hydraulic Control		
104	4070566	Shim 1/8"	A/R	
105	4070643	Shim 1/4"	A/R	
106	1380124	Clip, Retainer	12	
107	4920986	Wire, Mechanics	A/R	
108	4070743	Shim 1/2"	1	
		<b>Note: Items 109 to 116 Hydraulic Control Machines Only.</b>	1	
109		Hose Tube Weldment (Left Side) Options:	1	
	4843143	60H with Hydraulic Control		
	4843153	70H with Hydraulic Control		
110	4843106	Crossover Weldment	1	
111	4340570	Support, Roller	2	
112	3860048	Roller	2	
113	3421673	Pin	2	
114	4070727	Shim	4	
115	3841071	Rod	1	
116	4564881	Tubing, Wear	1	

**SECTION 3 BOOM**

# SECTION 3 BOOM

**FIGURE 3-1. BOOM COMPONENT ASSEMBLIES (CONTINUED)**

FIG & ITEM #	PART NUMBER	DESCRIPTION	QTY.	REV.
	0236044	<b>CHAIN ADJUSTER ASSEMBLY (REFER TO ITEM 83 FOR USAGE)</b>	Ref.	B
	0236294	<b>CHAIN ADJUSTER ASSEMBLY (REFER TO ITEM 48 FOR USAGE)</b>	Ref.	D
201	3509182	Plate	2	
202	Not Used			
203	0630374	Eyebolt	1	
204		Block, Chain Attach Options:	2	
	0560554	Chain Adjuster Assembly - 0236044		
	0560588	Chain Adjuster Assembly - 0236294		
205	0630347	Bolt 1/2"-13NC x 2 1/4" (Grade 8)	2	
206	3450405	Pin, Cotter 1/8" x 1 1/4"	2	
207	3311803	Nut, Slotted 1/2"-13NC	2	
208	3421142	Pin, Clevis 3/4" x 2"	1	
209	3450505	Pin, Cotter 5/32" x 1 1/4"	1	
210	4712200	Flatwasher 3/4" Narrow	1	
	1280732	<b>BOOM TAPE INSTALLATIONS</b>	Ref.	H
301	4420018	Tape - Blue	A/R	
		60H Standard Spec	119 in.	
		60H CSA/2:1 Stability Spec	108 in.	
		70H Standard Spec	147 in.	
		70H CSA/2:1 Stability Spec	137 in.	
302	4420016	Tape - Yellow	A/R	
		60H Standard Spec	27 in.	
		60H CSA/2:1 Stability Spec	33.5 in.	
		70H Standard Spec	33.5 in.	
		70H CSA/2:1 Stability Spec	37 in.	
303	4420017	Tape - Red	A/R	
		60H Standard Spec	42 in.	
		60H CSA/2:1 Stability Spec	47 in.	
		70H Standard Spec	45.5 in.	
		70H CSA/2:1 Stability Spec	52 in.	
	0236631	<b>STEERING TUBE INSTALLATION</b>	Ref.	B
401	4340447	Support, Tube (Left Side)	3	
402	4300036	Stud (Not Shown - Use with Item 401)	6	
403	3311401	Nut 1/4"-20NC (Not Shown - Use with Item 401)	6	
404	4751400	Flatwasher 1/4" (Not Shown - Use with Item 401)	6	
405	4761400	Lockwasher 1/4" (Not Shown - Use with Item 401)	6	
406	4060568	Shield (Left Side - Front)	1	
407	4842120	Crossover Weldment	1	
408	4060699	Shield (Left Side - Rear)	1	

**SECTION 3 BOOM**

# SECTION 3 BOOM

FIGURE 3-2. BOOM WIPERS INSTALLATION

MOOB 3 NOICES

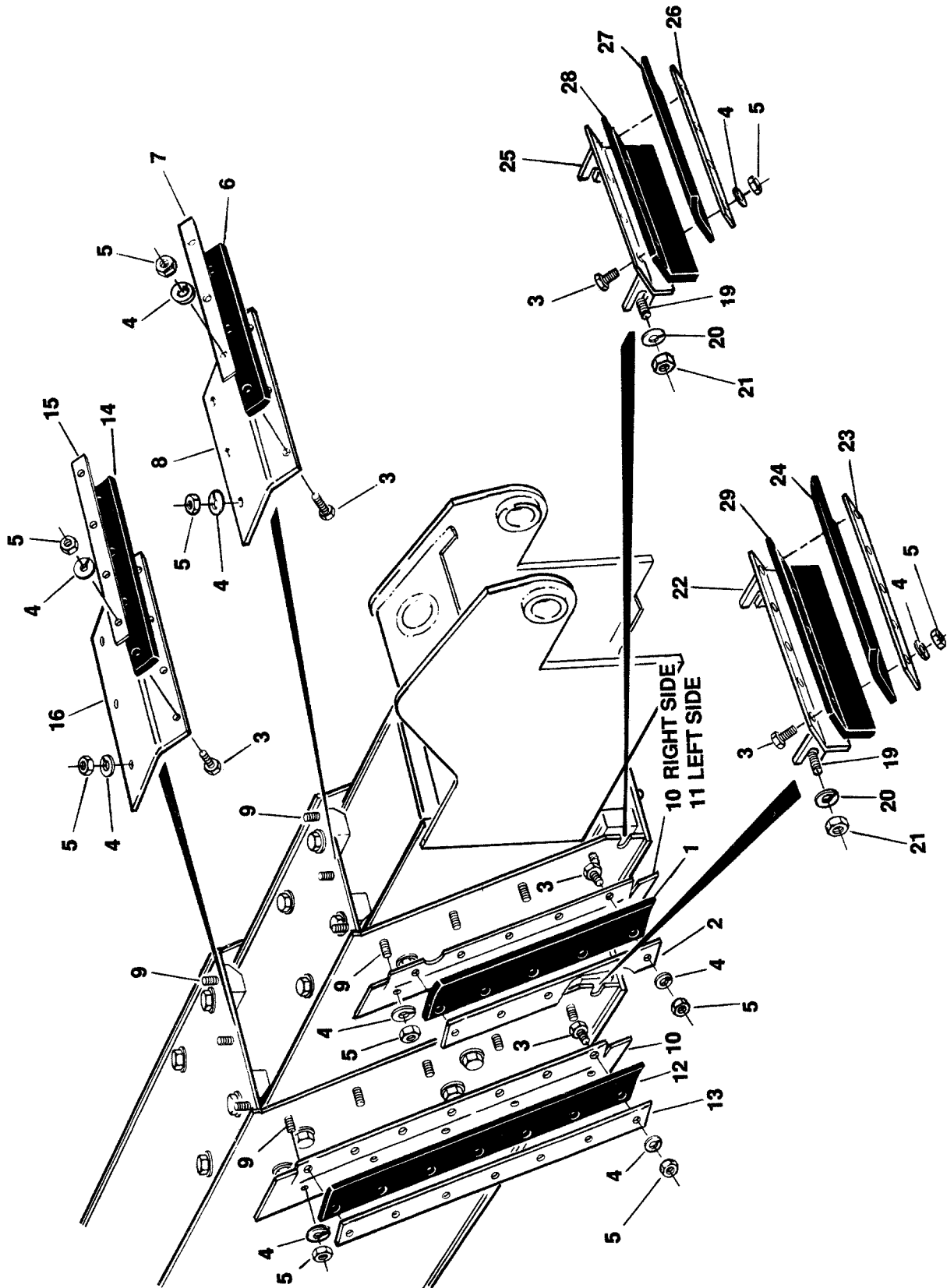

# SECTION 3 BOOM

**FIGURE 3-2. BOOM WIPERS INSTALLATION**

FIG & ITEM #	PART NUMBER	DESCRIPTION	QTY.	REV.
	0236155	<b>BOOM WIPERS INSTALLATION</b>	Ref.	B
1	0540061	Blade, Rubber (Mid Sides)	2	
2	4280229	Retainer, Strip (Mid Sides)	2	
3	0641407	Bolt 1/4"-20NC x 7/8"	37	
4	4761400	Lockwasher 1/4"	71	
5	3311401	Nut 1/4"-20NC	62	
6	0540045	Blade, Wiper (Mid Top)	1	
7	4280195	Retainer, Strip (Mid Top)	1	
8	2660040	Holder, Blade (Mid Top)	1	
9	4300031	Stud (Welded on Part)	24	
10	2660035	Holder, Blade (Mid Right Side)	1	
11	2660036	Holder, Blade (Mid Left Side)	1	
12	0540060	Blade, Wiper (Base Sides)	2	
13	4280228	Retainer, Strip (Base Sides)	2	
14	0540043	Blade, Wiper (Base Top)	1	
15	4280192	Retainer, Strip (Base Top)	1	
16	2660039	Holder, Blade (Base Top)	1	
17	2660037	Holder, Blade (Base Right Side)	1	
18	2660038	Holder, Blade (Base Left Side)	1	
19	4300034	Stud (Welded on Part)	8	
20	4751600	Flatwasher 3/8"	8	
21	3311601	Nut 3/8"-16NC	8	
22	2660033	Holder, Blade (Base Bottom)	1	
23	4280193	Retainer, Strip (Base Bottom)	1	
24	0540044	Blade, Wiper (Base Bottom)	1	
25	2660031	Holder, Blade (Mid Bottom)	1	
26	4280197	Retainer, Strip (Mid Bottom)	1	
27	0540047	Blade, Wiper (Mid Bottom)	1	
28	3960325	Seal (Mid Bottom)	1	
29	3960324	Seal (Base Bottom)	1	

SECTION 3 BOOM

# SECTION 3 BOOM

FIGURE 3-3. EXTEND-A-REACH INSTALLATIONS (60H+6 MACHINES)

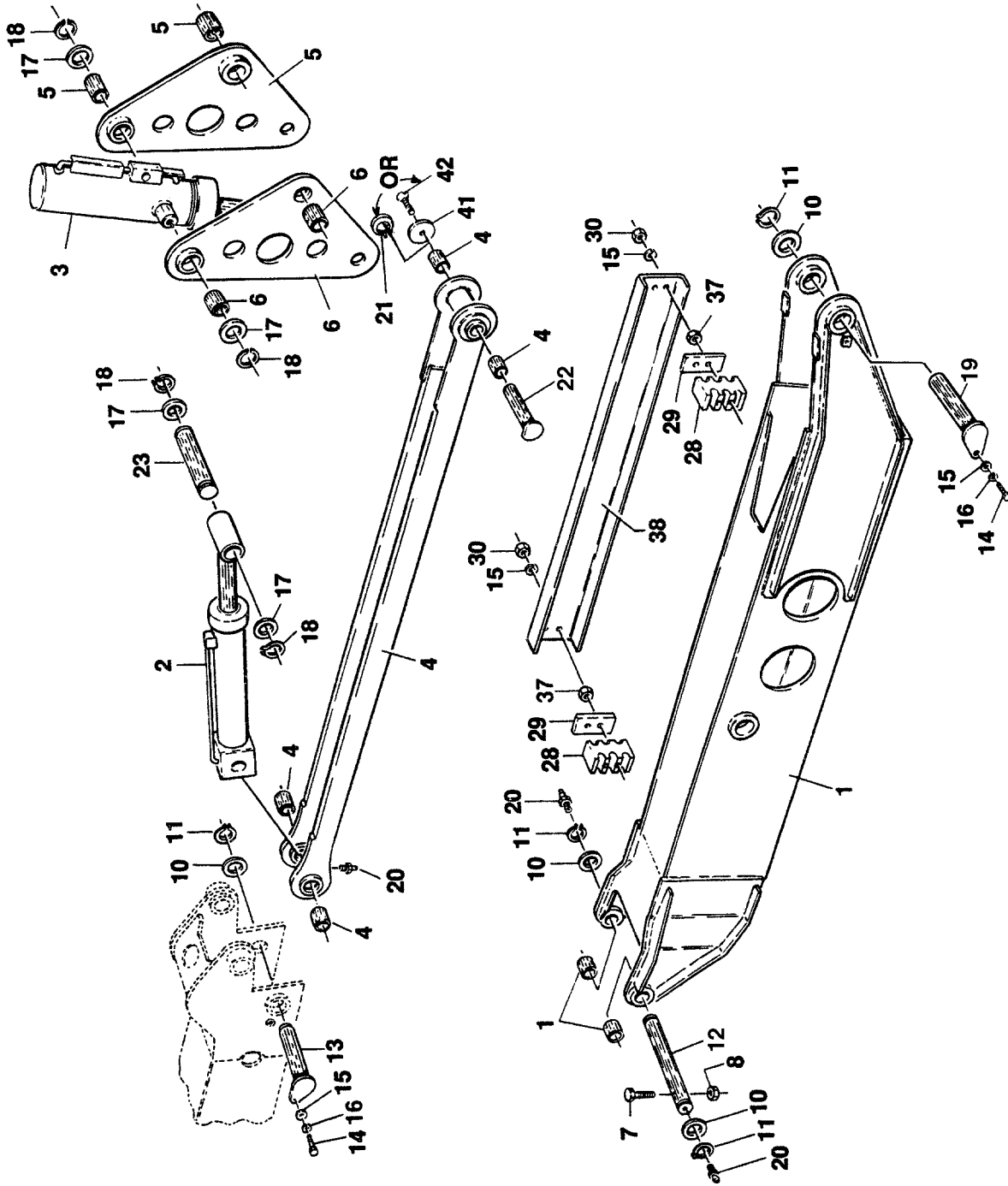

SECTION 3 BOOM



# SECTION 3 BOOM

**FIGURE 3-3. EXTEND-A-REACH INSTALLATIONS (60H+6 MACHINES)**

FIG & ITEM #	PART NUMBER	DESCRIPTION	QTY.	REV.
		<b>EXTEND-A-REACH INSTALLATIONS (60H+6 MACHINES)</b>	Ref.	
	0237673	<b>EXTEND-A-REACH INSTALLATION - STANDARD (PRIOR TO FEBRUARY 1991)</b>	Ref.	J
	0251632	<b>EXTEND-A-REACH INSTALLATION - STANDARD (FEBRUARY 1991 TO S/N 40600)</b>	Ref.	3
	0258949	<b>EXTEND-A-REACH INSTALLATION - STANDARD (S/N 40600 TO PRESENT)</b>	Ref.	1
	0251494	<b>EXTEND-A-REACH INSTALLATION - CSA (PRIOR TO S/N 40600)</b>	Ref.	4
	0258950	<b>EXTEND-A-REACH INSTALLATION - CSA (S/N 40600 TO PRESENT)</b>	Ref.	1
1		Snoot Weldment Options:	1	
	4842579	Prior to S/N 40600		
	4845930	S/N 40600 to Present		
	0961185	Bushing, Bronze	2	
2	1681730	Extend-A-Reach Lift Cylinder Assembly (See Section 5 for Breakdown)	1	
3		Extend-A-Reach Slave Level Cylinder Assembly (See Section 5 for Breakdown)	1	
	1681791	Cylinder (Prior to February 1991)		
	1682459	Cylinder (February 1991 to S/N 29914)		
	1683494	Cylinder (S/N 29914 to Present)		
4	4842601	Link Weldment	1	
	0961185	Bushing, Bronze (Boom Attach End)	2	
	0961098	Bushing, Bronze (Pivot Plate Attach End)	2	
5	4842606	Plate, Pivot (Right Side)	1	
	0961200	Bushing, Bronze (Front Center)	1	
	0961201	Bushing, Bronze (Top)	1	
6	4842605	Plate, Pivot (Left Side)	1	
	0961200	Bushing, Bronze (Front Center)	1	
	0961201	Bushing, Bronze (Top)	1	
7	0641622	Bolt 3/8"-16NC x 2 3/4"	1	
8	3311605	Locknut 3/8"-16NC	1	
9	0100011	Loctite #242 (Not Shown)	A/R	
10	4740332	Washer, Special	4	
11	3760233	Ring, Retaining	4	
12		Pin Options:	1	
	3421428	Prior to February 1991		
	3421823	February 1991 to Present		
	3421819	CSA Spec		
13	3421511	Pin	1	
14	0641606	Bolt 3/8"-16NC x 3/4"	2	
15	4751600	Flatwasher 3/8"	6	
16	4761600	Lockwasher 3/8"	2	
17	4740333	Washer, Special	4	
18	3760237	Ring, Retainer	4	

**SECTION 3 BOOM**

# SECTION 3 BOOM

**FIGURE 3-3. EXTEND-A-REACH INSTALLATIONS (60H+6 MACHINES) (CONTINUED)**

FIG & ITEM #	PART NUMBER	DESCRIPTION	QTY.	REV.
19		Pin Options:	1	
	3421513	Standard (Prior to S/N 40600)		
	3422768	Standard (S/N 40600 to Present)		
	3421821	CSA Spec (Prior to S/N 40600)		
	3422766	CSA Spec (S/N 40600 to Present)		
20	2160002	Fitting, Grease	6	
21	3760133	Ring, Retaining (Prior to February 1991)	1	
22		Pin Options:	1	
	3421429	Prior to February 1991		
	3421950	February 1991 to Present		
	3421950	CSA Spec		
23	3421376	Pin	1	
24	Not Used			
25	Not Used			
26	Not Used			
27	Not Used			
28	1320145	Clamp	2	
29	0361524	Bar	2	
30	3311605	Locknut 3/8"-16NC	4	
31	Not Used			
32	Not Used			
33	Not Used			
34	Not Used			
35	Not Used			
36	4300076	Stud 3/8"-16NC x 3 (Welded on Parts) (Not Shown)	4	
37	3311602	Nut, Jam 3/8"-16NC	4	
38	1670456	Cover, Hose	1	
39	Not Used			
40	2880508	Keystock (Not Shown) (Prior to S/N 40600)	1	
41	4740390	Washer	1	
42	0741606	Screw, Countersunk 3/8"-16NC x 3/4"	1	

**SECTION 3 BOOM**

# SECTION 4 PLATFORMS

<b>TABLE OF CONTENTS</b>		
<b>FIGURE</b>	<b>DESCRIPTION</b>	<b>PAGE</b>
4-1	STANDARD PLATFORM & FOOTSWITCH INSTALLATION . . . . .	4-2
4-2	LOW MOUNT PLATFORM & FOOTSWITCH INSTALLATION . . . . .	4-8
4-3	ROTATOR MOTOR ASSEMBLY . . . . .	4-14
4-4	CONSOLE BOX ASSEMBLIES - PQ Controllers Without Prop Tele (Machines Built Prior to September 1991) . . . . .	4-16
4-5	CONSOLE BOX ASSEMBLIES - PQ Controllers With Prop Tele (Machines Built Prior to September 1991) . . . . .	4-20
4-6	CONSOLE BOX ASSEMBLIES - PQ Controllers & Vickers Prop Valve (Machines Built September 1991 to Present) . . . . .	4-24
4-7	CONSOLE BOX ASSEMBLY - OEM Controllers . . . . .	4-30
4-8	CONSOLE BOX ASSEMBLY - Hydraulic Controls . . . . .	4-34
4-9	CAPACITY INDICATOR INSTALLATION (Optional) . . . . .	4-38
4-10	OPTIONAL COMMON PLATFORM MOUNTED COMPONENTS . . . . .	4-44

SECTION 4 PLATFORMS

# SECTION 4 PLATFORMS

FIGURE 4-1. STANDARD PLATFORM AND FOOTSWITCH INSTALLATION

SECTION 4 PLATFORMS

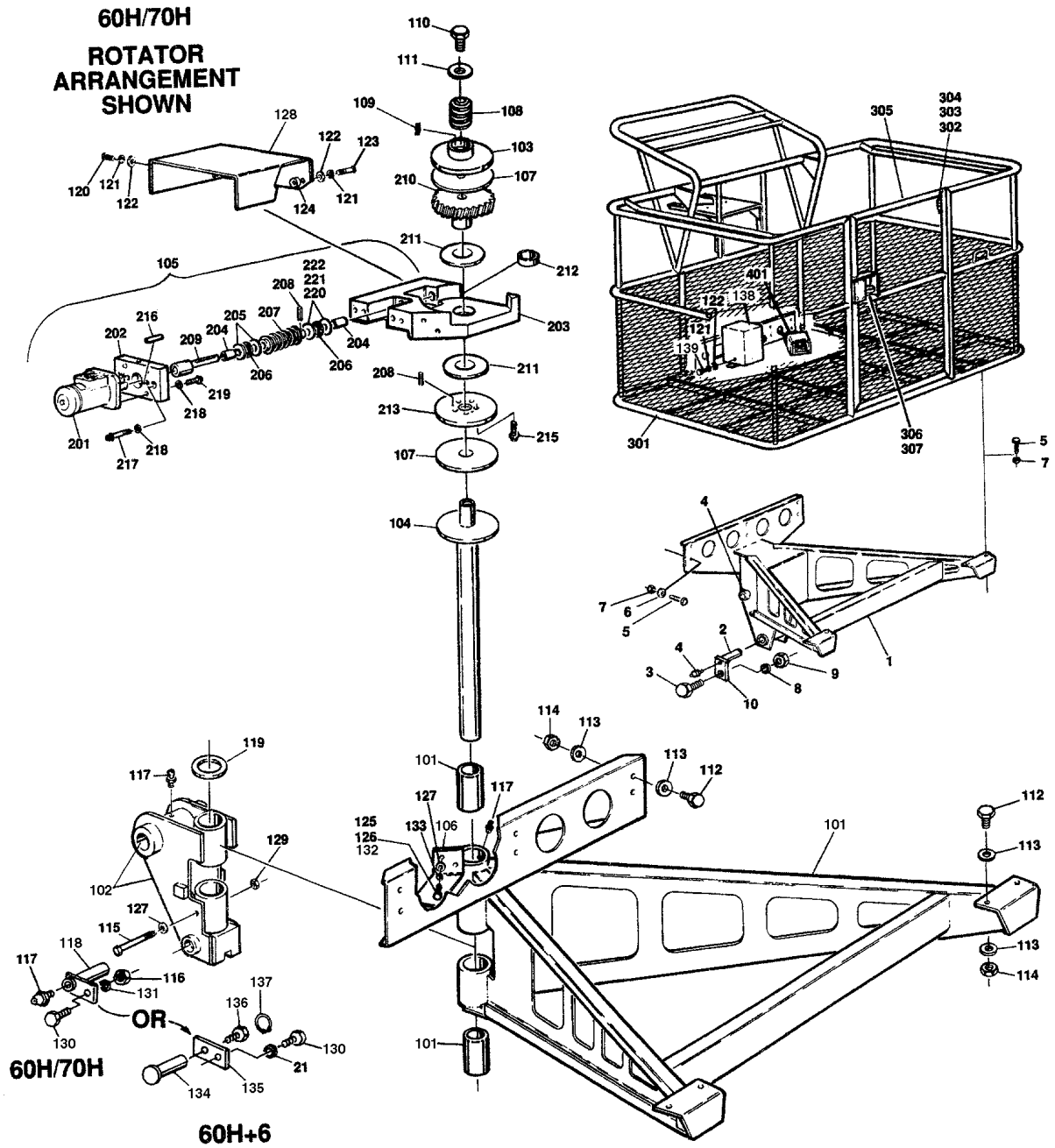

# SECTION 4 PLATFORMS

**FIGURE 4-1. STANDARD PLATFORM AND FOOTSWITCH INSTALLATION**

FIG & ITEM #	PART NUMBER	DESCRIPTION	QTY.	REV.
		<b>STANDARD PLATFORM AND FOOTSWITCH INSTALLATION</b>	Ref.	
	0236830	<b>FIXED SUPPORT INSTALLATION - MODEL 60H/70H</b>	Ref.	A
	0238154	<b>FIXED SUPPORT INSTALLATION - MODEL 60H+6</b>	Ref.	B
1		Support Weldment Options:	1	
	4842403	Support Weldment (60H/70H)		
	0961024	Bushing	2	
	4842817	Support Weldment (60H+6) (Not Shown)		
	0961185	Bushing	2	
2		Pin Options:	1	
	3421176	60H/70H		
		60H+6 Options:		
	3421426	Pin (Prior to January 1991)		
	3421825	Pin (January 1991 to November 1991)		
	3422019	Pin (November 1991 to Present)		
3		Bolt Options:	1	
	0641608	Bolt 3/8"-16NC x 1" (60H/70H)		
	0641405	Bolt 1/4"-20NC x 5/8" (Use After November 1991 Only) (60H+6)		
4	2160002	Fitting, Grease	A/R	
5	0681610	Bolt 3/8"-16NC x 1 1/4"	10	
6	4751600	Flatwasher 3/8"	A/R	
7		Locknut Options:	10	
	3311605	Locknut 3/8"-16NC (60H/70H)		
	3300143	Locknut 3/8" (60H+6)		
8	4761600	Lockwasher 3/8"	1	
9		Nut 3/8"-16NC Options:	1	
	3311601	60H/70H		
	Not Required	60H+6		
10		Hardware Options:	1	
		60H/70H Options:		
		Plate (Part of Item 2)		
		60H+6 Options:		
		Retainer Options:		
	Not Required	(Prior to January 1991)		
	4740385	Washer (January 1991 to November 1991)		
	0362079	Bar (November 1991 to Present)		
	3900159	Screw, Countersunk 1/2"-13NC x 3/4" (Not Shown - Used After January 1991)		
	3760237	Ring, Retaining (Not Shown - Used Prior to January 1991)		

**SECTION 4 PLATFORMS**

# SECTION 4 PLATFORMS

**FIGURE 4-1. STANDARD PLATFORM AND FOOTSWITCH INSTALLATION (CONTINUED)**

FIG & ITEM #	PART NUMBER	DESCRIPTION	QTY.	REV.
	0236831	ROTATOR AND SUPPORT INSTALLATION - MODEL 60H/70H (DOMESTIC/STANDARD)	Ref.	G
	0251459	ROTATOR AND SUPPORT INSTALLATION - MODEL 60H/70H (CSA/2=1 STABILITY)	Ref.	4
	0237672	ROTATOR AND SUPPORT INSTALLATION - MODEL 60H+6 (DOMESTIC/STANDARD)	Ref.	5
	0251488	ROTATOR AND SUPPORT INSTALLATION - MODEL 60H+6 (CSA/2=1 STABILITY)	Ref.	5
101		Support Weldment Options:	1	
	0236261	60H/70H		
	4842609	60H+6		
	0960564	Bushing, Bronze	2	
102		Pivot Weldment Options:	1	
	0236741	60H/70H		
	0961024	Bushing, Bronze	2	
		60H+6 Pivot Weldment Options:		
	0237975	Pivot (Prior to January 1991)		
	0251512	Pivot (January 1991 to Present)		
	0961185	Bushing, Bronze	2	
103	1120299	Cap	1	
104		Rotator Shaft Options:	1	
	4842046	Shaft (Standard/Domestic)		
	Use 4842046	Shaft (CSA/2:1 Stability) (was p/n 4040218)		
105	0235238	Rotator Assembly (See Items 201-226 for Breakdown)	1	
106		Mount Options:	1	
	3200194	Mount (60H/70H)		
	0901411	Mount, Rotator (Not Shown) (60H+6)		
107	3340454	Pad, Brake	2	
108	4160026	Washer, Belleville	8	
109	2880404	Key	1	
110	0652014	Bolt 5/8"-18NF x 1 3/4"	1	
111	4752000	Flatwasher 5/8"	1	
112	0681610	Bolt 3/8"-16NC x 1 1/4" (Grade 8)	10	
113	4751600	Flatwasher 3/8"	21	
114	3300143	Locknut 3/8"-16NC	10	
115	0641836	Bolt 1/2"-13NC x 4 1/2"	1	
116	3311601	Nut 3/8"-16NC	1	
117	2160002	Fitting, Grease	4	
118		Pin Options:	1	
	3421176	60H/70H		
	Not Required	60H+6		
119	4740158	Washer, Thrust	1	
120	0641404	Bolt 1/4"-20NC x 1/2"	1	
121	4761400	Lockwasher 1/4"	A/R	
122	4751400	Flatwasher 1/4"	A/R	
123	0641408	Bolt 1/4"-20NC x 1"	1	
124	4562083	Spacer	1	
125	0641811	Bolt 1/2"-13NC x 1 3/8"	2	

# SECTION 4 PLATFORMS

**FIGURE 4-1. STANDARD PLATFORM AND FOOTSWITCH INSTALLATION (CONTINUED)**

FIG & ITEM #	PART NUMBER	DESCRIPTION	QTY.	REV.
126	1380137	Clip, Retainer	2	
127	4751800	Flatwasher 1/2"	1	
128		Cover, Rotator Options:	1	
	1670322	60H/70H		
	1670421	60H+6		
129	3311805	Locknut 1/2"-13NC	1	
130		Bolt Options:	1	
	0641612	Bolt 3/8"-16NC x 1 1/2" (60H/70H)		
	0641405	Bolt 1/4"-20NC x 5/8" (60H+6) (Used after November 1991)		
131		Lockwasher 3/8" Options:	1	
	4761600	60H/70H		
	Not Required	60H+6		
132		Wire, Mechanics	A/R	
	4920986	60H/70H		
	4920385	60H+6		
133	4761800	Lockwasher 1/2"	2	
134		Pin Options:	1	
	Not Required	60H/70H		
		60H+6 Options:	1	
	3421426	Pin (Prior to January 1991)		
	3421825	Pin (January 1991 to November 1991)		
	3422019	Pin (November 1991 to Present)		
	0100011	Loctite #242	A/R	
		<b>Note: Items 135 to 139 Used on 60H+6 Only</b>		
135		Retainer Options:	1	
	Not Required	(Prior to January 1991)		
	4740385	Washer (January 1991 to November 1991)		
	0362079	Bar (November 1991 to Present)		
136	3900159	Screw, Countersunk 1/2"-13NC x 3/4" (Used after January 1991)	1	
137	3760237	Ring, Retaining (Prior to January 1991)	1	
138	1670422	Cover, Motor	1	
139	0641406	Bolt 1/4"-20NC x 3/4"	2	
	0235238	<b>ROTATOR ASSEMBLY</b>	Ref.	E
		<b>Note: For Machines Built Prior to September 1991 refer to Service Information Bulletin #91-5 for required upgrade.</b>		
201	3160083	Rotator Motor Assembly (See Figure 4-3 for Breakdown)	1	
202	0080099	Adapter, Motor	1	
203	2760064	Housing, Gear	1	
204	0440134	Bearing, Sleeve	2	
205	4740199	Washer, Thrust	4	
206	0440120	Bearing, Thrust	2	
207	2440043	Gear, Worm	1	
208	3440816	Rollpin 1/4" x 1"	4	
209	0080098	Adapter, Motor to Worm Gear	1	

SECTION 4 PLATFORMS

# SECTION 4 PLATFORMS

**FIGURE 4-1. STANDARD PLATFORM AND FOOTSWITCH INSTALLATION (CONTINUED)**

FIG & ITEM #	PART NUMBER	DESCRIPTION	QTY.	REV.
210	2440044	Gear, Worm	1	
211	4740256	Washer, Thrust	2	
212	0440135	Bearing, Sleeve	1	
213	1760068	Disc, Brake	1	
214	Not Used			
215	3931010	Bolt, Socket Head #10-24NC x 5/8"	5	
216	3441228	Rollpin 3/8" x 1 3/4"	2	
217	3931620	Bolt, Socket Head 3/8"-16NC x 1 1/4"	2	
218	4761600	Lockwasher 3/8"	6	
219	3931612	Bolt, Socket Head 3/8"-16NC x 3/4"	4	
220	4070585	Shim .010	A/R	
221	4070586	Shim .005	A/R	
222	4070587	Shim .002	A/R	
223	0100019	Loctite #271 (Not Shown)	A/R	
224	0100021	Primer (Not Shown)	A/R	
225	2160001	Fitting, Grease - 90°	1	
226	3020025	Grease (Not Shown)	A/R	
		<b>PLATFORM WELDMENTS</b>	Ref.	
		<b>Note: Replacement Decals Must Be Ordered Separately - See Section 8.</b>	Ref.	
301		Standard Platform Options:	1	
		3' x 4' (91.5cm x 123cm):		
		60H/70H:		
	3510138	Platform (Prior to July 1993)		
	3510438	Platform (July 1993 to Present)		
		60H+6:		
	3510439	Platform		
		3' x 5' (91.5cm x 152.5cm):		
		60H/70H:		
	3510141	Platform with PQ Controllers (Prior to September 1990)		
	3510150	Platform with OEM Controllers (Prior to September 1990)		
	3510268	Platform (September 1990 to Present)		
	3510234	Platform with Welded-on Bumper		
	3510268	Platform with Chain-Attached Bumper		
	3510512	Platform with Mesh to Top Rail		
		60H+6:		
	3510271	Platform		
	3510319	Platform with Welded-on Bumper		
	3510271	Platform with Chain Attached Bumper		

**SECTION 4 PLATFORMS**



# SECTION 4 PLATFORMS

**FIGURE 4-1. STANDARD PLATFORM AND FOOTSWITCH INSTALLATION (CONTINUED)**

FIG & ITEM #	PART NUMBER	DESCRIPTION	QTY.	REV.
301 (cont'd)		3' x 6' (91.5cm x 183cm):		
		60H/70H		
		3510148 Platform with PQ Controllers (Prior to September 1990)		
		3510161 Platform with OEM Controllers (Prior to September 1990)		
		Continued		
		60H/70H		
		3510269 Platform (September 1990 to Present)		
		3510262 Platform with Welded-on Bumper		
		3510269 Platform with Chain Attached Bumper		
		3510685 Platform with Mesh to Top Rail		
		60H+6:		
		3510272 Platform		
		3510320 Platform with Welded-on Bumper		
		3510272 Platform with Chain Attached Bumper		
		3' x 8' (91.5cm x 244cm):		
		60H/70H		
		3510139 Platform with PQ Controller (Prior to September 1990)		
		3510153 Platform with OEM Controller (Prior to September 1990)		
		3510270 Platform (September 1990 to Present)		
		3510348 Platform with Welded-on Bumper		
	3510270 Platform with Chain Attached Bumper			
	3510506 Platform with Mesh to Top Rail			
		Standard Platform Components:		
302	2600095	Pin, Hinge	2	
303	3311805	Locknut 1/2"-13NC	2	
304	2160006	Fitting, Grease	2	
305		Door Options:	1	
	1780145	Door (Prior to September 1990)		
	1780252	Door (September 1990 to Present)		
	1780288	Door with Mesh to Top Rail		
306	2940006	Latch, Door	1	
307	2560010	Handle	1	
	0237963	<b>FOOTSWITCH INSTALLATION</b>	Ref.	7
401	0641408	Bolt 1/4"-20NC x 1"	3	
	3311405	Locknut 1/4"-20NC	3	
	4740362	Washer, Fender	3	
	4360031	Footswitch	1	
	7000625	Block, Contact	2	
	4460071	Connector, Strain Relief	1	

**SECTION 4 PLATFORMS**

# SECTION 4 PLATFORMS

FIGURE 4-2. LOW MOUNT PLATFORM AND FOOTSWITCH INSTALLATION

SECTION 4 PLATFORMS

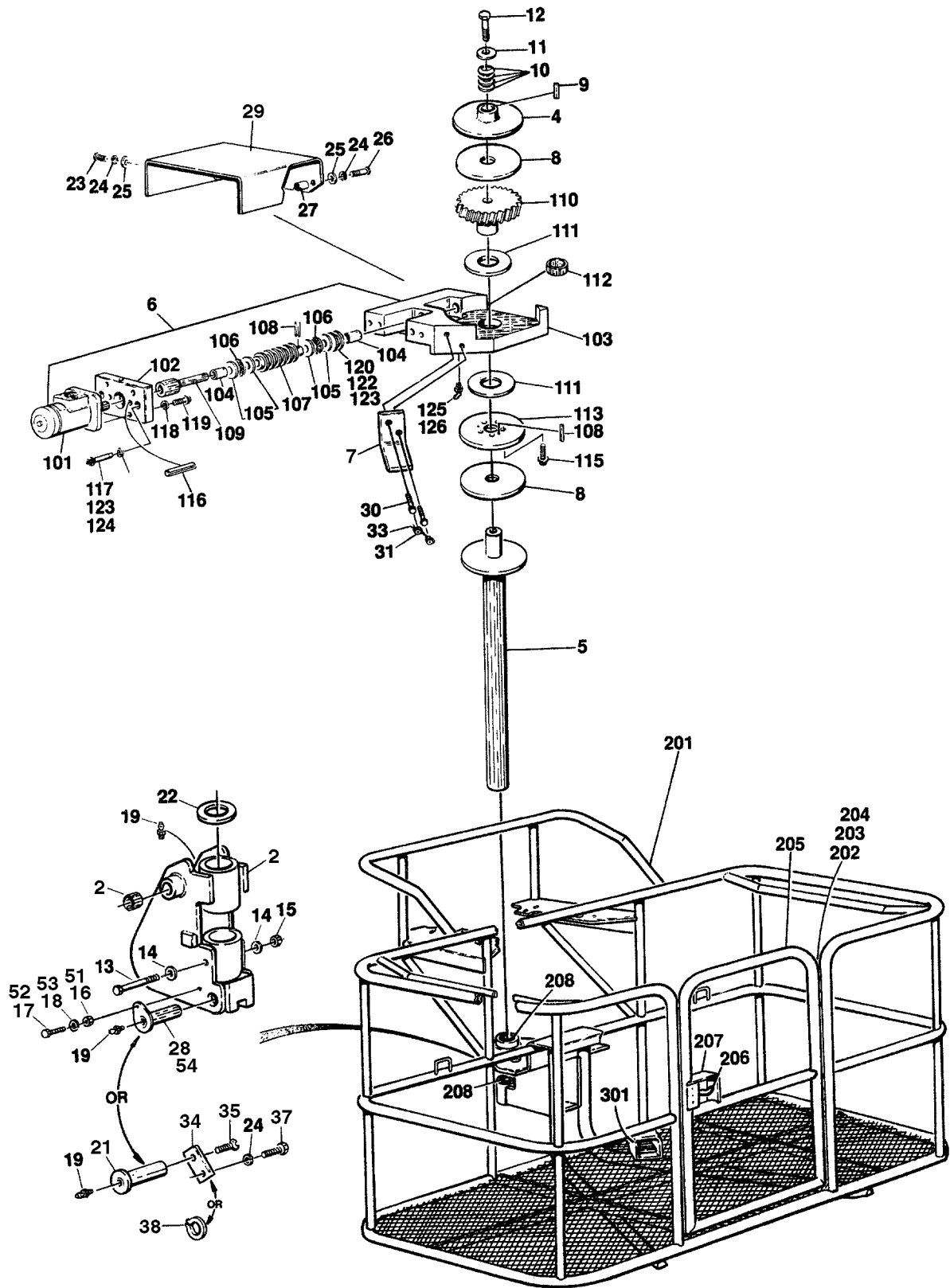

# SECTION 4 PLATFORMS

**FIGURE 4-2. LOW MOUNT PLATFORM AND FOOTSWITCH INSTALLATION**

FIG & ITEM #	PART NUMBER	DESCRIPTION	QTY.	REV.
		<b>LOW MOUNT PLATFORM AND FOOTSWITCH INSTALLATION</b>	Ref.	
	0239341	<b>ROTATOR AND SUPPORT INSTALLATION - MODELS 60H AND 70H (DOMESTIC/STANDARD)</b>	Ref.	8
	0251769	<b>ROTATOR AND SUPPORT INSTALLATION - MODELS 60H AND 70H (CSA/2:1 STABILITY)</b>	Ref.	5
	0239342	<b>ROTATOR AND SUPPORT INSTALLATION - MODEL 60H+6 (DOMESTIC/STANDARD)</b>	Ref.	G
	0251770	<b>ROTATOR AND SUPPORT INSTALLATION - MODEL 60H+6 (CSA/2:1 STABILITY)</b>	Ref.	5
1	Not Used			
2		Pivot Weldment Options:	1	
		60H/70H	1	
	0236741	Pivot Weldment	1	
	0961024	Bushing, Bronze	2	
		60H+6	2	
		Pivot Weldment Options:	1	
	0237975	Pivot (Prior to March 1991) (Not Shown)		
	0251512	Pivot (March 1991 to Present) (Not Shown)		
	0961185	Bushing, Bronze	2	
3	Not Used			
4	1120299	Cap	1	
5		Shaft Options:	1	
	4842046	Shaft (Domestic/Standard)		
	Use 4842046	Shaft (CSA/2:1 Stability) (was p/n 4040218)		
6	0235238	Rotator Assembly (See Items 101-126 for Breakdown)	1	
7		Mount Options:	1	
		60H/70H	1	
	0901525	Mount (Prior to July 1990)		
	0901721	Mount (July 1990 to S/N 34256)		
	0902414	Mount (S/N 34256 to Present)		
	0901524	60H+6	1	
8	3340454	Pad, Brake	2	
9	2880404	Key	1	
10	4160026	Washer, Belleville	8	
11	4752000	Flatwasher 5/8"	1	
12	0652014	Bolt 5/8"-18NF x 1 3/4"	1	
13	0641836	Bolt 1/2"-13NC x 4 1/2"	1	
14	4751800	Flatwasher 1/2"	1	
15	3311805	Locknut 1/2"-13NC	1	
16		Nut 3/8"-16NC Options:	1	
	3311601	60H/70H		
	Not Required	60H+6		
17		Bolt 3/8"-16NC x 1" Options:	1	
	0641608	60H/70H		
	Not Required	60H+6		

# SECTION 4 PLATFORMS

**FIGURE 4-2. LOW MOUNT PLATFORM AND FOOTSWITCH INSTALLATION (CONTINUED)**

FIG & ITEM #	PART NUMBER	DESCRIPTION	QTY.	REV.
18	4761600	Lockwasher 3/8" Options: 60H/70H	1	
	Not Required	60H+6		
19	2160002	Fitting, Grease	A/R	
20	Not Used			
21	Not Required	Pin Options: 60H/70H	1	
	3421426	60H+6 Options: Pin (Prior to March 1991)		
	3421825	Pin (March 1991 to November 1991)		
	3422019	Pin (November 1991 to Present)		
22	4740158	Washer, Thrust	1	
23	0641404	Bolt 1/4"-20NC x 1/2"	1	
24	4761400	Lockwasher 1/4"	2	
25	4751400	Flatwasher 1/4"	2	
26	0641408	Bolt 1k/4"-20NC x 1"	1	
27	4562083	Spacer, Tube	1	
28	Not Required	Pin Options: 60H/70H	1	
	3421176	60H+6		
29	Not Required	Cover Options: 60H/70H Options:	1	
	1670322	Cover (Prior to July 1990)		
	1670519	Cover (July 1990 to April 1992)		
	1670630	Cover (April 1992 to Present)		
	1670421	60H+6 Options: Cover (Prior to November 1992)		
	1670630	Cover (November 1992 to Present)		
30	0641811	Bolt 1/2"-13NC x 1 3/8"	2	
31	1380137	Clip, Retainer	2	
32	Not Used			
33	4920986	Wire, Mechanics	A/R	
34	Not Required	Retainer Options: 60H/70H	1	
	Not Required	60H+6 Options: (Prior to March 1991)		
	4740385	Washer (March 1991 to November 1991)		
	0362079	Bar (November 1991 to Present)		
35	Not Required	Hardware Options: 60H/70H	A/R	
	3900159	60H+6 - Screw, Countersunk 1/2"-13NC x 3/4" (Used March 1991 to Present)	1	
	0100011	Loctite #242	A/R	
36	Not Used			
37	Not Required	Hardware Options: 60H/70H	A/R	
	0641405	60H+6 - Bolt 1/4"-20NC x 5/8"	1	
38	Not Required	Hardware Options: 60H/70H	A/R	
	3760237	60H+6 - Ring, Retainer (Used Prior to March 1991)	1	

# SECTION 4 PLATFORMS

**FIGURE 4-2. LOW MOUNT PLATFORM AND FOOTSWITCH INSTALLATION (CONTINUED)**

FIG & ITEM #	PART NUMBER	DESCRIPTION	QTY.	REV.
	0250248	<b>FIXED SUPPORT INSTALLATION</b>	Ref.	A
51	3322601	Nut 3/8"-16NC	1	
52	0641609	Bolt 3/8"-16NC x 1 1/8"	1	
53	4761600	Lockwasher 3/8"	1	
54	3421176	Pin Weldment	1	
	0235238	<b>ROTATOR ASSEMBLY:</b> <b>Note: For Machines Built Prior to September 1991 refer to Service Information Bulletin #91-5 for required upgrade.</b>	Ref.	E
101	3160083	Rotator Motor Assembly (See Figure 4-3 for Breakdown)	1	
102	0080099	Adapter, Motor	1	
103	2760064	Housing, Gear	1	
104	0440134	Bearing, Sleeve	2	
105	4740199	Washer, Thrust	4	
106	0440120	Bearing, Thrust	2	
107	2440043	Gear, Worm	1	
108	3440816	Rollpin 1/4" x 1"	4	
109	0080098	Adapter, Motor to Worm Gear	1	
110	2440044	Gear, Worm	1	
111	4740256	Washer, Thrust	2	
112	0440135	Bearing, Sleeve	1	
113	1760068	Disc, Brake	1	
114	Not Used			
115	3931010	Bolt, Socket Head #10-24NC x 5/8"	5	
116	3441228	Rollpin 3/8" x 1 3/4"	2	
117	3931620	Bolt, Socket Head 3/8"-16NC x 1 1/4"	2	
118	4761600	Lockwasher 3/8"	6	
119	3931612	Bolt, Socket Head 3/8"-16NC x 3/4"	4	
120	4070585	Shim .010	A/R	
121	4070586	Shim .005	A/R	
122	4070587	Shim .002	A/R	
123	0100019	Loctite #271	A/R	
124	0200021	Primer	A/R	
125	2160001	Fitting, Grease - 90°	1	
126	3020025	Grease	A/R	
		<b>PLATFORM WELDMENTS</b>	Ref.	
		<b>Note: Replacement Decals Must Be Ordered Separately - See Section 8.</b>	Ref.	
201		Low Mount Platform Options: 3' x 5' (91.5cm x 152.5cm)	1	
	3510231	Platform - Fixed Support		
	3510194	Platform - Rotating Support (Prior to August 1990)		

# SECTION 4 PLATFORMS

**FIGURE 4-2. LOW MOUNT PLATFORM AND FOOTSWITCH INSTALLATION (CONTINUED)**

FIG & ITEM #	PART NUMBER	DESCRIPTION	QTY.	REV.	
201 (cont'd)	3510276	Platform - Rotating Support (August 1990 to Present)			
	3510254	Platform with Welded-on Bumpers (Standard Controls)			
	3510279	Platform with Welded-on Bumpers (Hydraulic Controls)			
	3510276	Platform with Chain Attached Bumpers			
	3510512	Platform with Mesh to Top Rail 3' x 6' (91.5cm x 183cm)			
	3510223	Platform - Rotating Support (Prior to August 1990)			
	3510277	Platform - Rotating Support (August 1990 to Present)			
	3510393	Platform with Welded-on Bumpers			
	3510277	Platform with Chain-Attached Bumpers 3' x 8' (91.5cm x 244cm)			
	3510211	Platform - Rotating Support (Prior to August 1990)			
	3510278	Platform - Rotating Support (August 1990 to Present)			
	3510380	Platform with Welded-on Bumpers			
	3510278	Platform with Chain Attached Bumpers			
			Standard Platform Components	A/R	
	202	2600143	Pin, Hinge	2	
	203	3311805	Locknut 1/2"-13NC	2	
204	2160006	Fitting, Grease	2		
205	1780145	Door Weldment (Machines Built Prior to April 1990)	1		
	1780252	Door Weldment (Machines Built August 1990 to Present)	1		
	1780288	Door Weldment with Mesh to Top Rail	1		
206	2940006	Latch, Door	1		
207	2560010	Handle	1		
208	0960564	Bushing, Bronze	2		
	0237963	<b>FOOTSWITCH INSTALLATION</b>	Ref.	7	
301	0641408	Bolt 1/4"-20NC x 1"	3		
	3311405	Locknut 1/4"-20NC	3		
	4740362	Washer, Fender	3		
	4360031	Footswitch	1		
	7000625	Block, Contact	2		
	4460071	Connector, Strain Relief	1		

**SECTION 4 PLATFORMS**

# SECTION 4 PLATFORMS

FIGURE 4-2. LOW MOUNT PLATFORM AND FOOTSWITCH INSTALLATION (CONTINUED)

FIG & ITEM #	PART NUMBER	DESCRIPTION	QTY.	REV.

**S  
E  
C  
T  
I  
O  
N  
4  
P  
L  
A  
T  
F  
O  
R  
M  
S**

# SECTION 4 PLATFORMS

FIGURE 4-3. ROTATOR MOTOR ASSEMBLY

SECTION 4 PLATFORMS

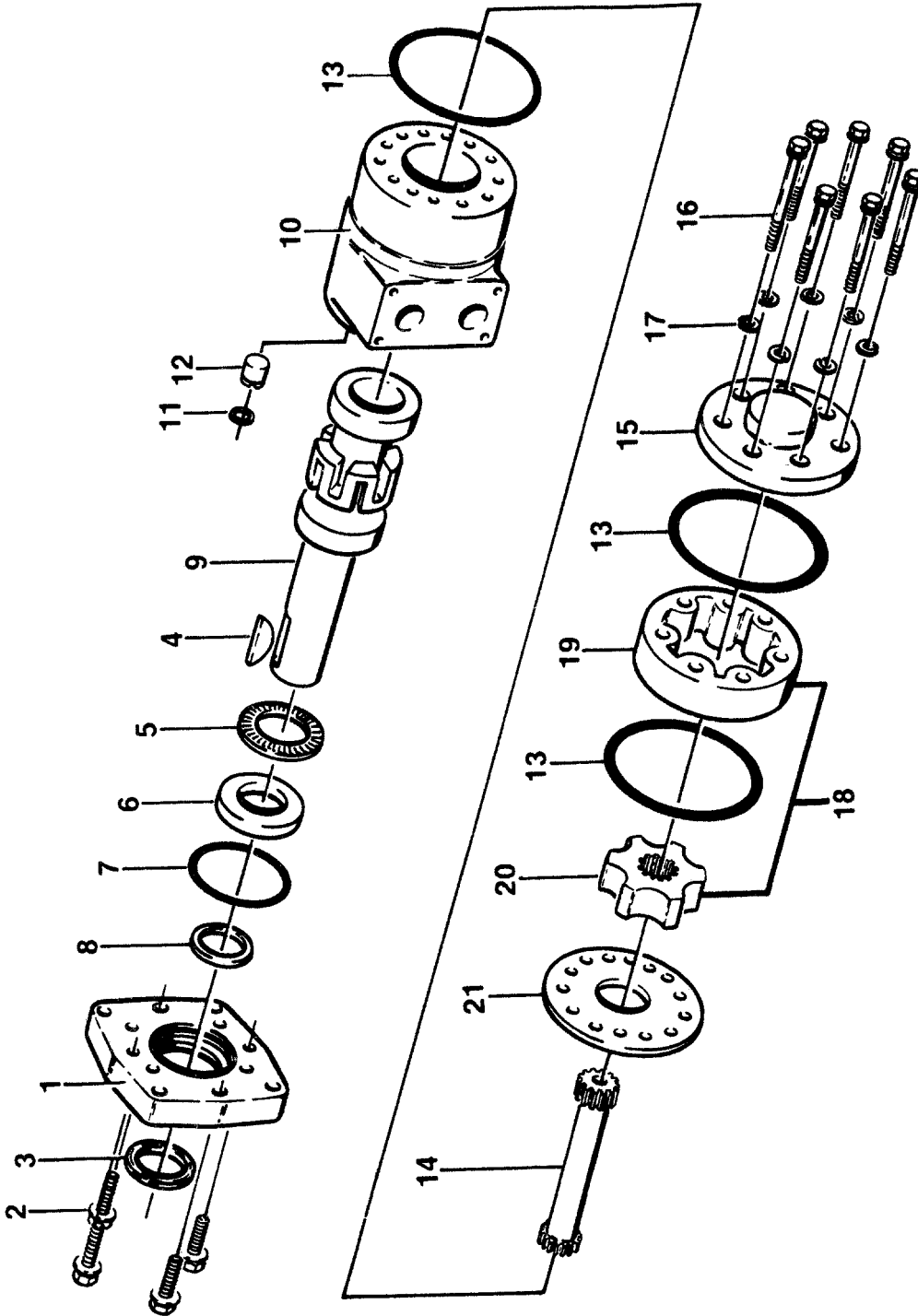



# SECTION 4 PLATFORMS

**FIGURE 4-3. ROTATOR MOTOR ASSEMBLY**

FIG & ITEM #	PART NUMBER	DESCRIPTION	QTY.	REV.
	3160083	<b>ROTATOR MOTOR ASSEMBLY</b>	Ref.	B
1	7002105	Flange, Mounting	1	
2	7002123	Screw, Cap	4	
3	Kit	Seal, Dust	1	
4	7002104	Key, Woodruff	1	
5	7002111	Bearing, Thrust Needle	1	
6	7002117	Thrust, Bearing Race	1	
7	Kit	Seal, O-Ring	1	
8	Kit	Seal, Pressure	1	
9	7002116	Shaft, Output	1	
10	7002103	Housing	1	
11	Kit	Seal	1	
12	7009992	Plug, Housing	1	
13	Kit	Seal, O-Ring	3	
14	7002112	Drive	1	
15	7002107	Cap, End	1	
16	7002100	Screw, Cap	7	
17	7000166	Lockwasher	7	
18	7002125	Gerotor Sub-Assembly	1	
19	7002110	Plate, Spacer	1	
		-----		
	2900455	Seal Kit (Includes Items 3,7,8, 11 and 13) (P/N 101-1009-007)	1	
	2900733	Seal Kit (Includes Items 3,7,8,11 and 13) (P/N's 101-1009-008 and 101-1009-009)	1	
		<b>Note: Identify by P/N stamped on nameplate located on Item 10.</b>		

# SECTION 4 PLATFORMS

FIGURE 4-4. CONSOLE BOX ASSEMBLIES - PQ CONTROLLERS WITHOUT PROP TELE (MACHINES BUILT PRIOR TO SEPTEMBER 1991)

SECTION 4 PLATFORMS

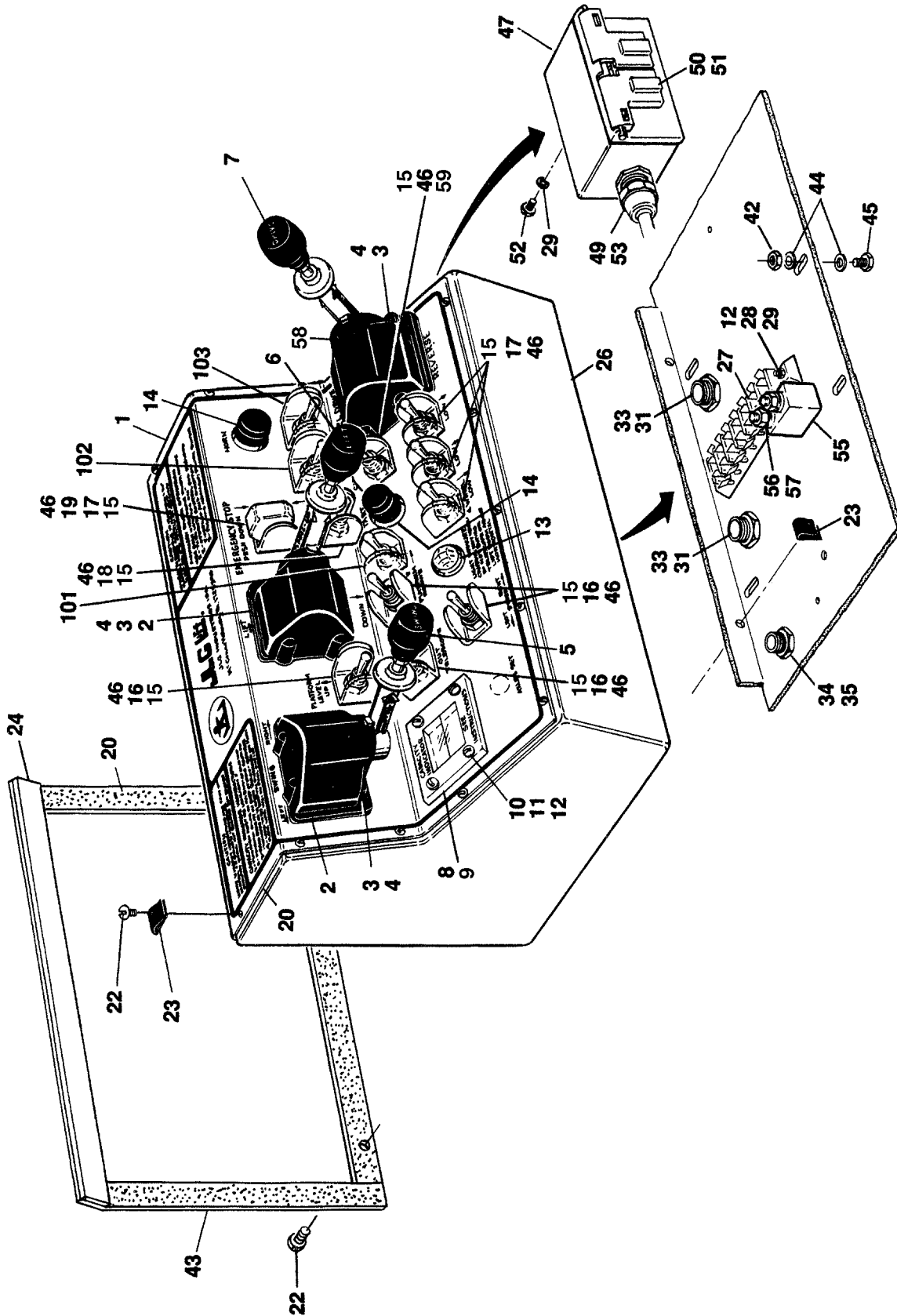

# SECTION 4 PLATFORMS

**FIGURE 4-4. CONSOLE BOX ASSEMBLIES - PQ CONTROLLERS WITHOUT PROP TELE (MACHINES BUILT PRIOR TO SEPTEMBER 1991)**

FIG & ITEM #	PART NUMBER	DESCRIPTION	QTY.	REV.
		<b>CONSOLE BOX ASSEMBLIES - PQ CONTROLLERS WITHOUT PROP TELE (MACHINES BUILT PRIOR TO SEPTEMBER 1991)</b>	Ref.	
	0236497	<b>CONSOLE ASSEMBLY (MACHINES WITH RACINE PROP VALVES AND WITHOUT CAPACITY INDICATOR AND WITH SOLENOID THROTTLE)</b>	Ref.	9
	0237041	<b>CONSOLE BOX ASSEMBLY (MACHINES WITH RACINE PROP VALVES AND WITHOUT CAPACITY INDICATOR AND WITH ADECO THROTTLE)</b>	Ref.	F
	0236493	<b>CONSOLE BOX ASSEMBLY (MACHINES WITH RACINE PROP VALVES WITH CAPACITY INDICATOR AND WITH SOLENOID THROTTLE)</b>	Ref.	9
	0237040	<b>CONSOLE BOX ASSEMBLY (STANDARD MACHINES WITH RACINE PROP VALVES AND WITH CAPACITY INDICATOR AND WITH ADECO THROTTLE)</b>	Ref.	G
	0237089	<b>CONSOLE BOX ASSEMBLY (CSA MACHINES WITH RACINE PROP VALVE AND WITH CAPACITY INDICATOR AND WITH ADECO THROTTLE)</b>	Ref.	D
	0237943	<b>CONSOLE BOX ASSEMBLY (2WD MACHINES WITH VICKERS PROP VALVE AND WITHOUT CAPACITY INDICATORS)</b>	Ref.	E
	0237942	<b>CONSOLE BOX ASSEMBLY (STANDARD 2WD MACHINES WITH VICKERS PROP VALVE AND WITH CAPACITY INDICATOR)</b>	Ref.	I
	0251667	<b>CONSOLE BOX ASSEMBLY (CSA 2WD MACHINES WITH VICKERS PROP VALVE AND WITH CAPACITY INDICATOR)</b>	Ref.	C
	0238199	<b>CONSOLE BOX ASSEMBLY (4WD MACHINES WITH VICKERS PROP VALVES AND WITHOUT CAPACITY INDICATOR)</b>	Ref.	E
	0238198	<b>CONSOLE BOX ASSEMBLY (STANDARD 4WD MACHINES WITH VICKERS VALVES AND WITH CAPACITY INDICATOR)</b>	Ref.	G
	0238255	<b>CONSOLE BOX ASSEMBLY (CSA 4WD MACHINES WITH VICKERS VALVE AND WITH CAPACITY INDICATOR)</b>	Ref.	G
1		Lid Console Options:	1	
	3251537	Machines With Racine Prop Valves And Without/ With Capacity Indicator		
	3251741	2WD Machines With Vickers Prop Valve And Without/With Capacity Indicators		
	3252086	CSA 2WD Machines With Vickers Prop Valve And With Capacity Indicator		
	3251741	Standard/CSA 4WD Machines With Vickers Prop Valves And Without/With Capacity Indicator		
2	1600094	Controller, PQ	2	
	7003737	Electrical Assembly	2	
3	0720803	Bolt #8-32NC x 3/8"	12	
4	4760800	Lockwasher #8	12	
5	2560040	Knob, Controller (Swing)	1	

SECTION 4 PLATFORMS

# SECTION 4 PLATFORMS

**FIGURE 4-4. CONSOLE BOX ASSEMBLIES - PQ CONTROLLERS WITHOUT PROP TELE  
(MACHINES BUILT PRIOR TO SEPTEMBER 1991) (CONTINUED)**

FIG & ITEM #	PART NUMBER	DESCRIPTION	QTY.	REV.
6	2560038	Knob, Controller (Lift)	1	
7	2560041	Knob, Controller (Drive)	1	
8	3960251	Gasket	1	
9		Decal - Capacity Options:	1	
	3251551	Machines Without Capacity Indicator		
	2960006	Machines With Capacity Indicator		
	Not Required	CSA 2WD Machines With Vickers Prop Valve And With Capacity Indicator		
10	3911014	Screw, Round Head #10-24NC x 7/8"	4	
11	4771000	Starwasher #10	4	
12	3311001	Nut #10-24NC	6	
13	2920015	Lamp	1	
14	4360274	Switch, Push Button	2	
15		Shield, Switch Options:	A/R	
	4060087	All Machines except CSA 2WD	A/R	
	4060229	CSA 2WD Machines With Vickers Prop Valve And With Capacity Indicator	9	
16	4360202	Switch, Toggle	4	
17	4360199	Switch, Toggle	4	
18		Switch, Toggle Options:	1	
	4360204	Machines With Racine Valves		
	4360200	Machines With Vickers Valve		
19	4360141	Guard, Switch	1	
20	4420038	Tape, Insulation	34 in.	
21	0100001	Adhesive (Not Shown)	A/R	
22	0751006	Screw #10-24NC x 3/4"	15	
23	3300177	Nut, Tinnerman	15	
24	3960250	Weatherstrip	16"	
25	0100009	Silicone-RTV (Not Shown)	A/R	
26	0860472	Box, Weldment	1	
27	4460263	Strip, Terminal	1	
28	3911012	Screw, Round Head #10-24NC x 3/4"	2	
29	4761000	Lockwasher #10	6	
30	Not Used			
31	3300048	Locknut, Conduit	2	
32	4460071	Connector, Strain Relief	1	
33	4460051	Connector, Strain Relief	1	
34	3300047	Locknut, Conduit	1	
35	4460052	Connector, Strain Relief	1	
36 to 40	Not Used			
41	0100011	Loctite #242 (Not Shown)	A/R	
42	3311405	Locknut 1/4"-20NC	4	
43	3509858	Plate, Rear Cover	1	
44	4751400	Flatwasher 1/4"	8	
45	0641407	Bolt 1/4"-20NC x 7/8"	4	
46	3790012	O-Ring	A/R	
47	0860038	Box, Receptacle	1	
48	Not Used			
49	4460049	Connector, Strain Relief	1	

# SECTION 4 PLATFORMS

**FIGURE 4-4. CONSOLE BOX ASSEMBLIES - PQ CONTROLLERS WITHOUT PROP TELE  
(MACHINES BUILT PRIOR TO SEPTEMBER 1991) (CONTINUED)**

FIG & ITEM #	PART NUMBER	DESCRIPTION	QTY.	REV.
50	4460190	Receptacle	1	
51	4060092	Shield, Weatherproof	1	
52	3900294	Screw, Machine #10-16NC x 1"	4	
53	0960407	Bushing	1	
54	Not Used			
55	4360209	Breaker, Circuit 20 Amp	1	
56	3321001	Nut #10-32NF	2	
57	4751000	Flatwasher #10	2	
58		Controller, PQ Options:	1	
	1600094	2WD Machines		
	7003737	Electrical Assembly	1	
	1600095	4WD Machines		
	7003746	Electrical Assembly	1	
59		Switch, Toggle (2WD/4WD) Options:	1	
	Not Required	2WD Machines		
	4360199	4WD Machines		
		<b>OPTIONAL INSTALLATIONS</b>	Ref.	
101		Glow Plug Control Components (Location may vary)		
	4360200	Switch, Toggle	1	
	4060087	Shield, Switch	1	
	3790012	O-Ring	1	
102		Beacon Lights Controls Components		
103		Lights Controls Components		
	4360199	Switch, Toggle	1	
	4060087	Shield, Switch	1	
	3790012	O-Ring	1	

**SECTION 4 PLATFORMS**

# SECTION 4 PLATFORMS

FIGURE 4-5. CONSOLE BOX ASSEMBLIES - PQ CONTROLLERS WITH PROP TELE (MACHINES BUILT PRIOR TO SEPTEMBER 1991)

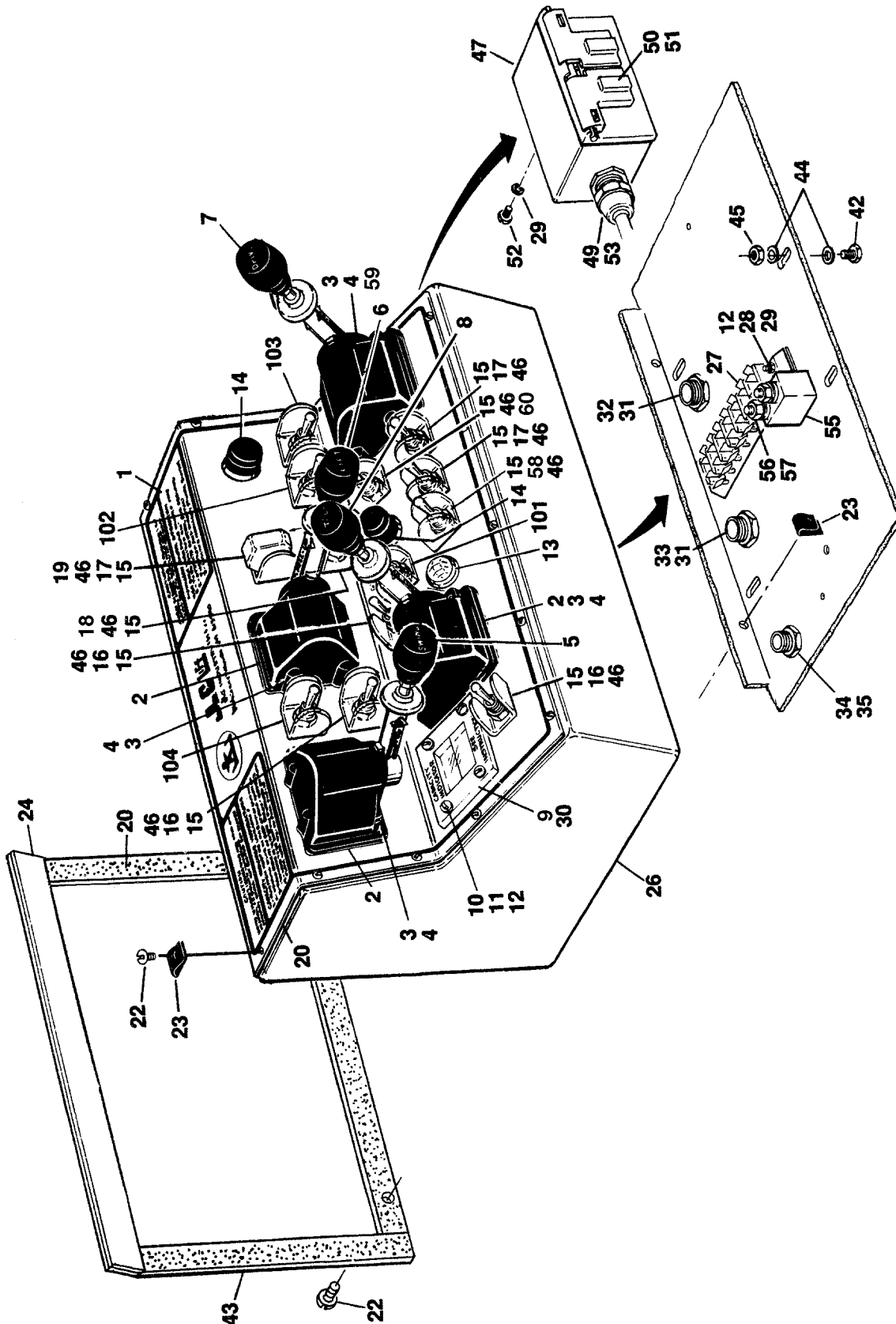

SECTION 4 PLATFORMS

# SECTION 4 PLATFORMS

**FIGURE 4-5. CONSOLE BOX ASSEMBLIES - PQ CONTROLLERS WITH PROP TELE (MACHINES BUILT PRIOR TO SEPTEMBER 1991)**

FIG & ITEM #	PART NUMBER	DESCRIPTION	QTY.	REV.
		<b>CONSOLE BOX ASSEMBLIES - PQ CONTROLLERS WITH PROP TELE (MACHINES BUILT PRIOR TO SEPTEMBER 1991)</b>	Ref.	
	0236821	<b>CONSOLE BOX ASSEMBLY (MACHINES WITH RACINE VALVES AND WITHOUT CAPACITY INDICATOR)</b>	Ref.	J
	0236822	<b>CONSOLE BOX ASSEMBLY (MACHINES WITH RACINE VALVES WITH CAPACITY INDICATOR)</b>	Ref.	J
	0237948	<b>CONSOLE BOX ASSEMBLY (2WD MACHINES WITH VICKERS VALVE AND WITHOUT CAPACITY INDICATOR)</b>	Ref.	E
	0237947	<b>CONSOLE BOX ASSEMBLY (2WD MACHINES WITH VICKERS VALVE AND WITH CAPACITY INDICATOR)</b>	Ref.	F
	0238216	<b>CONSOLE BOX ASSEMBLY (4WD MACHINES WITH VICKERS VALVES AND WITHOUT CAPACITY INDICATOR)</b>	Ref.	E
	0238215	<b>CONSOLE BOX ASSEMBLY (4WD MACHINES WITH VICKERS VALVE AND WITH CAPACITY INDICATOR)</b>	Ref.	E
1	3251742	Lid, Console	1	
2	1600094	Controller, PQ	3	
	7003737	Electrical Assembly	3	
3	0720803	Bolt #8-32NC x 3/8"	12	
4	4760800	Lockwasher #8	12	
5	2560040	Knob, Controller (Swing)	1	
6	2560038	Knob, Controller (Lift)	1	
7	2560041	Knob, Controller (Drive)	1	
8	2560039	Knob, Controller (Tele)	1	
9		Decal - Capacity Options:	1	
	3251551	Decal - Capacity (Machines Without Capacity Indicator)		
	2960006	Lens, Capacity Indicator (Machines With Capacity Indicator)		
10	3911014	Screw, Round Head #10-24NC x 7/8"	4	
11	4771000	Starwasher #10	4	
12	3311001	Nut #10-24NC	6	
13	2920015	Lamp	1	
14	4360274	Switch, Push Button	2	
15	4060087	Shield, Switch	A/R	
16	4360202	Switch, Toggle	3	
17	4360199	Switch, Toggle	3	
18		Toggle Switch Options:	1	
	4360204	Machines With Racine Valves		
	4360200	Machines With Vickers Valves		
19	4360141	Guard, Switch	1	
20	4420038	Tape, Insulation	34 in.	
21	0100001	Adhesive (Not Shown)	A/R	
22	0751006	Screw #10-24NC x 3/4"	15	
23	3300177	Nut, Tinnerman	15	

**SECTION 4 PLATFORMS**

# SECTION 4 PLATFORMS

**FIGURE 4-5. CONSOLE BOX ASSEMBLIES - PQ CONTROLLERS WITH PROP TELE (MACHINES BUILT PRIOR TO SEPTEMBER 1991) (CONTINUED)**

FIG & ITEM #	PART NUMBER	DESCRIPTION	QTY.	REV.
24	3960240	Weatherstrip	16"	
25	0100009	Silicone - RTV (Not Shown)	A/R	
26	0860472	Box Weldment	1	
27	4460263	Strip, Terminal	1	
28	3911012	Screw, Round Head #10-24NC x 3/4"	2	
29	4761000	Lockwasher #10	6	
30	3960251	Gasket	1	
31	3300048	Locknut, Conduit	2	
32	4460071	Connector, Strain Relief	1	
33	4460051	Connector, Strain Relief	1	
34	3300047	Locknut, Conduit	1	
35	4460052	Connector, Strain Relief	1	
36 to 40	Not Used			
41	0100011	Loctite #242 (Not Shown)	A/R	
42	3311405	Locknut 1/4"-20NC	4	
43	3509858	Plate, Rear Cover	1	
44	4751400	Flatwasher 1/4"	8	
45	0641407	Bolt 1/4"-20NC x 7/8"	4	
46	3790012	O-Ring	A/R	
47	0860038	Box, Receptacle	1	
48	Not Used			
49	4460049	Connector, Strain Relief	1	
50	4460190	Receptacle	1	
51	4060092	Shield, Weatherproof	1	
52	3911008	Screw, Machine #10-24NC x 1/2"	4	
53	0960407	Bushing	1	
54	Not Used			
55	4360209	Breaker, Circuit - 20 Amp	1	
56	3321001	Nut #10-32NF	2	
57	4751000	Flatwasher #10	2	
58		Switch, Toggle (Wheel Speed) Options:	1	
	Not Required	Machines with Racine Valves		
	4360199	Machines with Vickers Valves		
59		Controller, PQ Options:	1	
	1600094	2WD - Controller, PQ		
	7003737	Electrical Assembly	1	
	1600095	4WD -Controller, PQ		
	7003746	Electrical Assembly	1	
60		Switch, Toggle(2WD/4WD) Options:	1	
	Not Required	2WD Machines		
	4360199	4WD Machines		
		<b>OPTIONAL INSTALLATIONS</b>	Ref.	
101		Glow Plug Control Components (Location may vary)		
	4360200	Switch, Toggle	1	
	4060087	Shield, Switch	1	
	3790012	O-Ring	1	
102		Beacon Lights Controls Components		

**SECTION 4 PLATFORMS**



# SECTION 4 PLATFORMS

**FIGURE 4-5. CONSOLE BOX ASSEMBLIES - PQ CONTROLLERS WITH PROP TELE (MACHINES BUILT PRIOR TO SEPTEMBER 1991) (CONTINUED)**

FIG & ITEM #	PART NUMBER	DESCRIPTION	QTY.	REV.
103	4360199	Lights Controls Components Switch, Toggle	1	
	4060087	Shield, Switch	1	
	3790012	O-Ring	1	
104		Extend-A-Reach Control Components (60H+6 Only)		
	4360202	Switch, Toggle	1	
	4060087	Shield, Switch	1	
	3790012	O-Ring	1	
	3251746	Nameplate	1	

SECTION 4 PLATFORMS

# SECTION 4 PLATFORMS

FIGURE 4-6. CONSOLE BOX ASSEMBLY - PQ CONTROLLERS AND VICKERS PROP VALVE (MACHINES BUILT SEPTEMBER 1991 TO PRESENT)

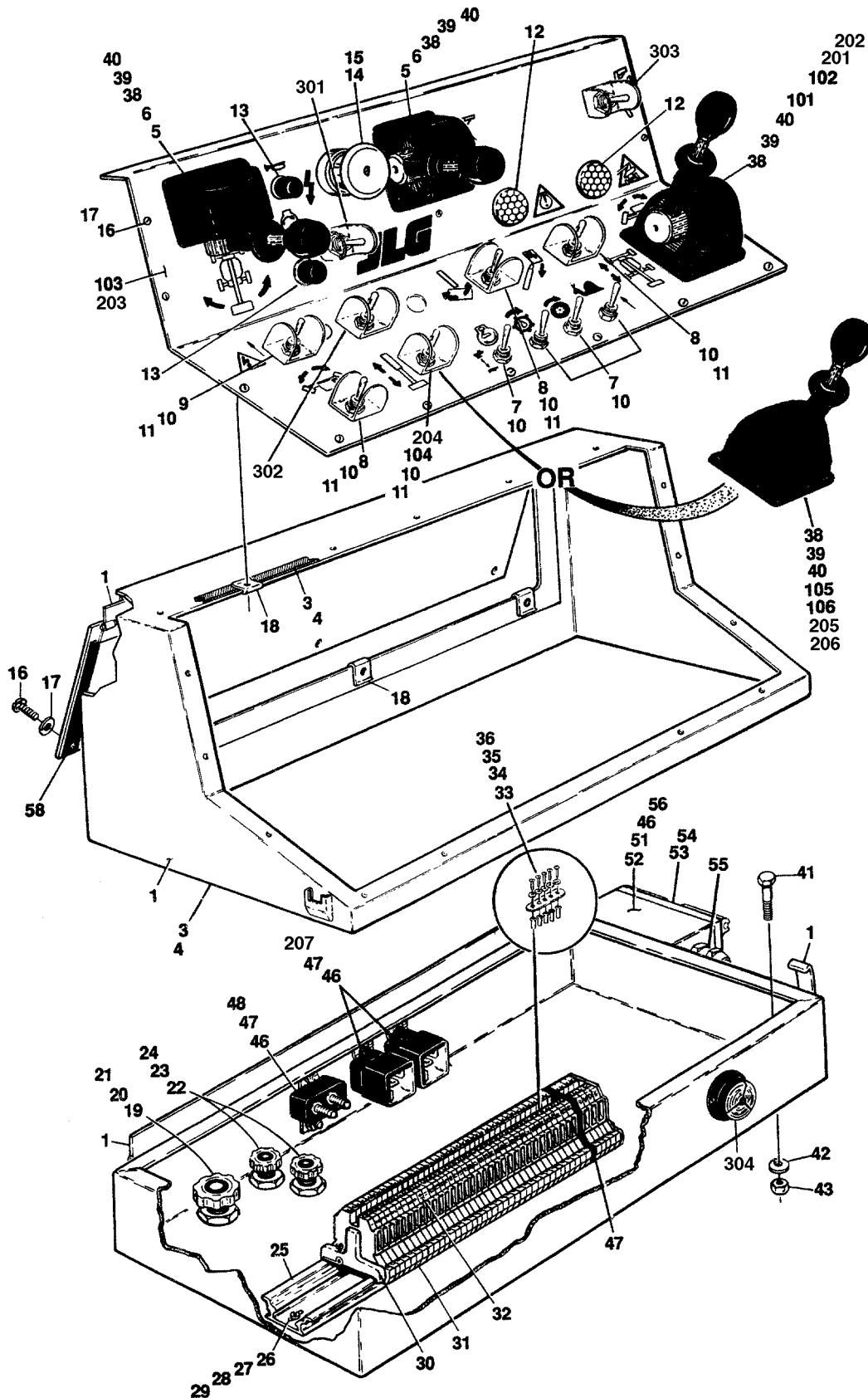

SECTION 4 PLATFORMS

# SECTION 4 PLATFORMS

**FIGURE 4-6. CONSOLE BOX ASSEMBLY - PQ CONTROLLERS AND VICKERS PROP VALVE  
(MACHINES BUILT SEPTEMBER 1991 TO PRESENT)**

FIG & ITEM #	PART NUMBER	DESCRIPTION	QTY.	REV.
		<b>CONSOLE BOX ASSEMBLIES</b>	Ref.	
		<b>CONSOLE BOX ASSEMBLY (STANDARD PARTS)</b>	Ref.	
1	0860739	Box Weldment	1	
	2940052	Latch	2	
	2600105	Hinge (Top)	1	
	2600132	Hinge (Bottom)	1	
	3531023	Rear Access Door	1	
2	Not Used			
3	4420008	Tape, Insulation	69 ft/ 1.75cm	
4	0100001	Adhesive	A/R	
5	1600141	Controller, PQ	2	
	7011907	Electrical Assembly	2	
6	2560112	Knob	2	
7	4360199	Switch, Toggle - SPST	4	
8	4360202	Switch, Toggle - DPDT/MC/CO	3	
9	4360200	Switch, Toggle - SPST/MC	1	
10	3790012	O-Ring	A/R	
11	4060229	Shield	5	
12	2920015	Lamp	2	
13	4360274	Switch, Push Button	2	
14		Switch, Emergency Stop Options:	1	
	4360289	Prior to October 1999		
	4360475	October 1999 to Present		
14A		Cap Options:	1	
	7012611	Cap, Mushroom Head (Used on Switch p/n 4360289)		
	7012612	Boot (Used on Switch p/n 4360289)	1	
	7020175	Cap, Red (Used on Switch p/n 4360475)		
	7020176	Contact Block (Used on Switch p/n 4360475)		
15		Block, Contact Options:	1	
	4360282	Prior to October 1999		
	4360476	October 1999 to Present		
16	0751006	Screw #10-24NC x 3/4"	21	
17	4740120	Washer, Nylon	21	
18	3300177	Nut, Tinnerman	21	
19	4460386	Connector, Strain Relief	1	
20	3300147	Nut, Conduit	1	
21	0960905	Bushing	1	
22	4460052	Connector, Strain Relief	2	
23	3300047	Nut, Conduit	2	
24	0960239	Bushing	2	
25	3640752	Track	1	
26	3910608	Screw #6-32NC x 1/2"	2	
27	4750600	Flatwasher #6	2	
28	4760600	Lockwasher #6	2	

# SECTION 4 PLATFORMS

**FIGURE 4-6. CONSOLE BOX ASSEMBLY - PQ CONTROLLERS AND VICKERS PROP VALVE  
(MACHINES BUILT SEPTEMBER 1991 TO PRESENT) (CONTINUED)**

FIG & ITEM #	PART NUMBER	DESCRIPTION	QTY.	REV.
29	3310601	Nut #6-32NC	2	
30	4460299	Stop, Terminal	2	
31	4460298	Block, Terminal	40	
32	4460301	Strip, Marking	1	
33	4460311	Bar, Buss	1	
34	4460305	Screw, Terminal	5	
35	4460306	Washer, Terminal	5	
36	4460307	Sleeve, Terminal	5	
37	4460300	Barrier, Terminal	3	
38	0720803	Screw, Machine #8-32NC x 3/8"	16	
39	4750800	Flatwasher #8	16	
40	4760800	Lockwasher #8	16	
41	0641508	Bolt 5/16"-18NC x 1"	4	
42	4751500	Flatwasher 5/16"	8	
43	3311505	Locknut 5/16"-18NC	4	
44	Not Used			
45	Not Used			
46	4761000	Lockwasher #10	A/R	
47	3311001	Nut #10-24NC	A/R	
48	4360209	Breaker, Circuit - 20 Amp	1	
49	Not Used			
50	Not Used			
51	3900294	Screw #10-16NC x 1" (Self Drilling)		
52	0860038	Box, Receptacle	1	
53	4460190	Receptacle (Standard) (See Section 10 for Special Options)	1	
54	4060092	Cover, Receptacle (Standard) (See Section 10 for Special Options)	1	
55	4460071	Connector, Strain Relief	1	
56	4751000	Flatwasher #10	4	
57	3520034	Plug (Not Shown)	2	
58	4420037	Tape, Insulation	45 in/ 38cm	
	0860743	<b>CONSOLE BOX ASSEMBLY - MACHINES WITH 2WS AND WITHOUT PROP TELE (VARIABLE PARTS)</b>	Ref.	8
	0860745	<b>CONSOLE BOX ASSEMBLY - MACHINES WITH 2WS AND WITH PROP TELE (VARIABLE PARTS)</b>	Ref.	8
101	1600141	Controller, PQ	1	
	7011907	Electrical Assembly	1	
102	2560112	Knob	1	
103		Lid Options:	1	
		Without Prop Tele:	1	
	3252140	Lid (Prior to May 1994)		
	3252353	Lid (May 1994 to November 1994)		
	3538394	Plate, Console Decal Mounting (November 1994 to Present)	1	
	1702404	Decal, Console (November 1994 to Present)	1	

**SECTION 4 PLATFORMS**

# SECTION 4 PLATFORMS

**FIGURE 4-6. CONSOLE BOX ASSEMBLY - PQ CONTROLLERS AND VICKERS PROP VALVE  
(MACHINES BUILT SEPTEMBER 1991 TO PRESENT) (CONTINUED)**

FIG & ITEM #	PART NUMBER	DESCRIPTION	QTY.	REV.
103 (cont'd)		With Prop Tele:	1	
	3252139	Lid (Prior to May 1994)		
	3252364	Lid (May 1994 to Present)		
	Consult Factory	Plate, Console Decal Mounting (November 1994 to Present)	1	
	Consult Factory	Decal, Console (November 1994 to Present)	1	
104		Switch, Toggle - DPDT/MC/CO Options:	1	
	4360202	Without Prop Tele		
	Not Required	With Prop Tele		
105		Controller, PQ Options:	A/R	
	Not Required	Without Prop Tele	0	
	1600141	With Prop Tele	1	
	7011907	Electrical Assembly	1	
106		Knob Options:	1	
	Not Required	Without Prop Tele		
	2560112	With Prop Tele		
107	Not Required			
	0860744	<b>CONSOLE BOX ASSEMBLY - MACHINES WITH 4WS AND WITHOUT PROP TELE (VARIABLE PARTS)</b>	Ref.	8
	0860842	<b>CONSOLE BOX ASSEMBLY - MACHINES WITH 4WS AND WITHOUT PROP TELE (VARIABLE PARTS)</b>	Ref.	7
	0860746	<b>CONSOLE BOX ASSEMBLY - MACHINES WITH 4WS AND WITH PROP TELE (VARIABLE PARTS)</b>	Ref.	8
201	1600140	Controller, PQ	1	
	7011903	Electrical Assembly	1	
	7003789	Switch, Steer	1	
202	Not Required			
203		Lid Options:	1	
		Without Prop Tele:		
	3252140	Lid (Prior to May 1994)		
	3252353	Lid (May 1994 to November 1994)		
	3538394	Plate, Console Decal Mounting (November 1994 to Present)	1	
	1702404	Decal, Console (November 1994 to Present)	1	
		With Prop Tele:	1	
	3252139	Lid (Prior to May 1994)		
	3252364	Lid (May 1994 to Present)		
204		Switch, Toggle - DPDT/MC/CO Options:	1	
	4360202	Without Prop Tele		
	Not Required	With Prop Tele		
205		Controller, PQ Options:	A/R	
	Not Required	Without Prop Tele	0	
	1600141	With Prop Tele	1	
	7011907	Electrical Assembly	1	
206		Knob Options:	1	
	Not Required	Without Prop Tele		
	2560112	With Prop Tele		

# SECTION 4 PLATFORMS

**FIGURE 4-6. CONSOLE BOX ASSEMBLY - PQ CONTROLLERS AND VICKERS PROP VALVE  
(MACHINES BUILT SEPTEMBER 1991 TO PRESENT) (CONTINUED)**

FIG & ITEM #	PART NUMBER	DESCRIPTION	QTY.	REV.
204	4360202	Switch, Toggle - DPDT/MC/CO	1	
207	3740049	Relay	2	
		<b>OPTIONAL INSTALLATIONS</b>	Ref.	
301		Choke/Glow Plug Components		
	4360200	Switch, Toggle - SPST	1	
	3790012	O-Ring	1	
	4060229	Shield	1	
302		Lights Components		
	4360199	Switch, Toggle - SPST	1	
	3790012	O-Ring	1	
	4060229	Shield	1	
303		Extend-A-Reach Components		
	4360202	Switch, Toggle - DPDT/MC/CO	1	
	3790012	O-Ring	1	
	4060229	Shield	1	
	0253077 /0254203	<b>TILT ALARM INSTALLATIONS</b>	Ref.	5/B
304	0140026	Alarm	1	
	1540002	Capacitor (Prior to S/N 38698)	1	

**SECTION 4 PLATFORMS**

# SECTION 4 PLATFORMS

**FIGURE 4-6. CONSOLE BOX ASSEMBLY - PQ CONTROLLERS AND VICKERS PROP VALVE  
(MACHINES BUILT SEPTEMBER 1991 TO PRESENT) (CONTINUED)**

FIG & ITEM #	PART NUMBER	DESCRIPTION	QTY.	REV.

**S  
E  
C  
T  
I  
O  
N  
  
4  
  
P  
L  
A  
T  
F  
O  
R  
M  
S**

# SECTION 4 PLATFORMS

FIGURE 4-7. CONSOLE BOX ASSEMBLY - OEM CONTROLLERS

SECTION 4 PLATFORMS

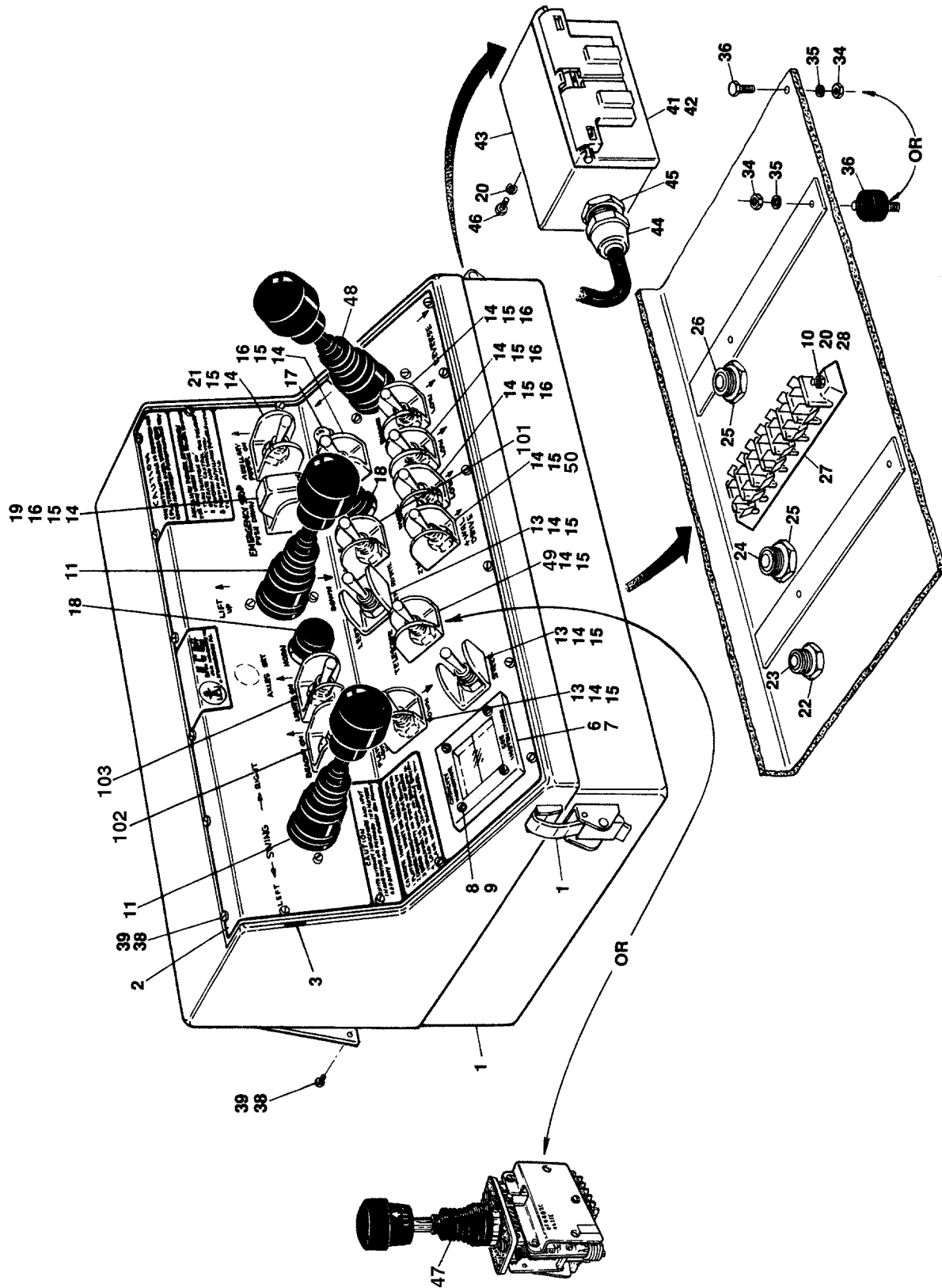



# SECTION 4 PLATFORMS

**FIGURE 4-7. CONSOLE BOX ASSEMBLY - OEM CONTROLLERS**

FIG & ITEM #	PART NUMBER	DESCRIPTION	QTY.	REV.
		<b>CONSOLE BOX ASSEMBLY - OEM CONTROLLERS</b>	Ref.	
	0238264	<b>CONSOLE BOX ASSEMBLY - 2WD MACHINES WITHOUT CAPACITY INDICATOR AND WITHOUT PROP TELE</b>	Ref.	7
	0238179	<b>CONSOLE BOX ASSEMBLY - 2WD MACHINES WITH CAPACITY INDICATOR AND WITHOUT PROP TELE AND WITH STANDARD PLATFORM</b>	Ref.	11
	0254737	<b>CONSOLE BOX ASSEMBLY - 2WD MACHINES WITH CAPACITY INDICATOR AND WITHOUT PROP TELE AND WITH LOW MOUNT PLATFORM</b>	Ref.	2
	0238263	<b>CONSOLE BOX ASSEMBLY - 2WD MACHINES WITHOUT CAPACITY INDICATOR AND WITH PROP TELE</b>	Ref.	7
	0238180	<b>CONSOLE BOX ASSEMBLY - 2WD MACHINES WITH CAPACITY INDICATOR AND WITH PROP TELE</b>	Ref.	8
	0238290	<b>CONSOLE BOX ASSEMBLY - 4WD MACHINES WITH CAPACITY INDICATOR AND WITHOUT PROP TELE</b>	Ref.	7
	0251918	<b>CONSOLE BOX ASSEMBLY - 4WD MACHINES WITHOUT CAPACITY INDICATOR AND WITH PROP TELE</b>	Ref.	3
	0238289	<b>CONSOLE BOX ASSEMBLY - 4WD MACHINES WITH CAPACITY INDICATOR AND WITH PROP TELE</b>	Ref.	7
1	0860538	Box Weldment	1	
	2600132	Hinge (Top to Bottom)	1	
	2600105	Hinge (Rear Access Door)	1	
	2940052	Latch	2	
2	3251678	Lid	1	
3	4420038	Tape, Insulation	45 in/ 38cm	
4	0100001	Adhesive (Not Shown)	A/R	
5	0100009	Silicone, RTV (Not Shown)	A/R	
6	3960251	Gasket	1	
7		Decal - Capacity Options:	1	
	3251551	Decal - Capacity (Machines Without Capacity Indicator)		
	2960006	Lens, Capacity Indicator (Machines With Capacity Indicator)		
8	3911014	Screw, Round Head #10-24NC x 7/8"	4	
9	4771000	Starwasher #10	4	
10	3311001	Nut #10-24NC	6	
11		Controller, OEM Options:	2	
	1600092	Prior to S/N 27148		
	1600247	S/N 27148 to Present		
12	Not Used			
13	4360202	Switch, Toggle - DPDT/MC/CO	3	
14	4060087	Shield, Switch	A/R	
15	3790012	O-Ring	A/R	
16	4360199	Switch, Toggle - SPST	5	
17	2920015	Lamp	1	

# SECTION 4 PLATFORMS

**FIGURE 4-7. CONSOLE BOX ASSEMBLY - OEM CONTROLLERS (CONTINUED)**

FIG & ITEM #	PART NUMBER	DESCRIPTION	QTY.	REV.
18	4360274	Switch, Push Button	2	
19	4360141	Guard, Switch	1	
20	4761000	Lockwasher #10	6	
21	4360200	Switch, Toggle - SPST/MC	1	
22	3300047	Locknut, Conduit	1	
23	4460052	Connector, Strain Relief	1	
24	4460051	Connector, Strain Relief	1	
25	3300048	Locknut, Conduit	2	
26	4460071	Connector, Strain Relief	1	
27	4460263	Strip, Terminal	1	
28	0721008	Screw #10-24NC x 1/2"	2	
29 to 33	Not Used			
34	3311505	Locknut 5/16"-18NC	4	
35	4751500	Flatwasher 5/16"	8	
36		Mounting Hardware Options	4	
	4320002	Stud with Rubber Mount (Prior to August 1990)	4	
	0641508	Bolt 5/16"-18NC (August 1990 to Present)		
37	Not Used			
38	0791006	Screw, Pan Head #10-24NC x 3/4"	21	
39	3300177	Nut, Tinnerman	21	
40	Not Used			
41	4060092	Cover, Weathershield	1	
42	4460190	Receptacle, Electrical	1	
43	0860038	Box, Receptacle	1	
44	4460049	Connector, Strain Relief	1	
45	0960407	Bushing	1	
46	3911008	Screw #10-24NC x 1/2"	4	
47		Controller, OEM (Tele) Options:	1	
	Not Required	Machines Without Prop Tele		
	1600092	Machines With Prop Tele (Prior to S/N 27148)		
	1600247	Machines With Prop Tele (S/N 27148 to Present)		
48		Controller, OEM (Drive) Options:	1	
	1600092	2WD Machines (Prior to S/N 27148)		
	1600247	2WD Machines (S/N 27148 to Present)		
	1600096	4WD Machines		
49		Switch, Toggle - DPDT/MC/CO (Tele) Options:	1	
	4360202	Machines Without Prop Tele		
	Not Required	Machines With Prop Tele		
50		Switch, Toggle - SPST (2WD/4WD) Options:	1	
	Not Required	2WD Machines		
	4360199	4WD Machines		
		<b>OPTIONAL INSTALLATIONS</b>	Ref.	
101		Glow Plug/Choke Components		
	4360199	Switch, Toggle - SPST	1	
	4060087	Shield, Switch	1	
	3790012	O-Ring	1	

**SECTION 4 PLATFORMS**

# SECTION 4 PLATFORMS

**FIGURE 4-7. CONSOLE BOX ASSEMBLY - OEM CONTROLLERS (CONTINUED)**

FIG & ITEM #	PART NUMBER	DESCRIPTION	QTY.	REV.
102	4360199	Beacon Components Switch, Toggle - SPST	1	
	4060087	Shield, Switch	1	
	3790012	O-Ring	1	
103	4360199	Lights Components Switch, Toggle - SPST	1	
	4060087	Shield, Switch	1	
	3790012	O-Ring	1	

# SECTION 4 PLATFORMS

FIGURE 4-8. CONSOLE BOX ASSEMBLY - HYDRAULIC CONTROLS

SECTION 4 PLATFORMS

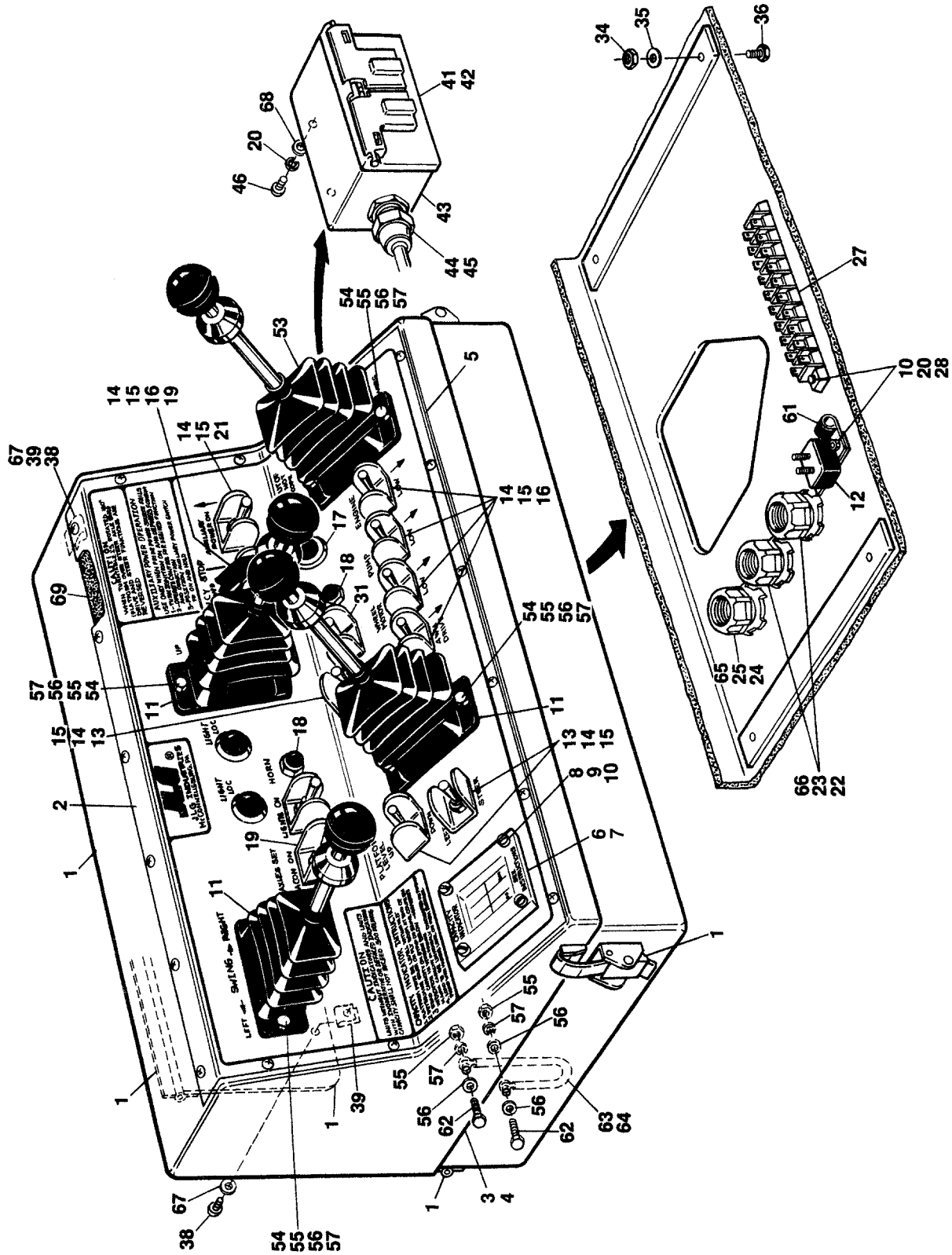

# SECTION 4 PLATFORMS

**FIGURE 4-8. CONSOLE BOX ASSEMBLY - HYDRAULIC CONTROLS**

FIG & ITEM #	PART NUMBER	DESCRIPTION	QTY.	REV.
		<b>CONSOLE BOX ASSEMBLIES</b>	Ref.	
	0250067	<b>CONSOLE BOX ASSEMBLY - MACHINES WITHOUT CAPACITY INDICATOR</b>	Ref.	J
	0239229	<b>CONSOLE BOX ASSEMBLY - STANDARD MACHINES WITH CAPACITY INDICATOR AND STANDARD PLATFORMS</b>	Ref.	16
	0250674	<b>CONSOLE BOX ASSEMBLY - CSA MACHINES WITH CAPACITY INDICATOR AND STANDARD PLATFORM</b>	Ref.	H
	0254246	<b>CONSOLE BOX ASSEMBLY - MACHINES WITH CAPACITY INDICATOR AND LOW MOUNT PLATFORM</b>	Ref.	D
1	0860565	Box Weldment	1	
	2950052	Latch	1	
	2600132	Hinge (Top to Bottom)	1	
	2600105	Hinge (Access Door)	1	
	3531023	Door, Access (Rear)	1	
2		Lid Options:	1	
	3251858	Lid (Prior to May 1994)		
	3252374	Lid (May 1994 to November 1994)		
	3538391	Plate, Console Decal Mounting (November 1994 to Present)		
	1702401	Decal, Console (November 1994 to Present)		
3	4420008	Tape, Insulation	69 in/ 1.75m	
4	0100001	Adhesive (Not Shown)	A/R	
5	0100009	Silicone, RTV (Not Shown)	A/R	
6	3960251	Gasket	1	
7	Not Used	Capacity Options:	1	
		Capacity Decal Options (Machines Without Capacity Indicator):		
	3251551	Decal (Prior to May 1994)		
	3252394	Decal (May 1994 to Present)		
	29600006	Lens, Capacity Indicator (Machines With Capacity Indicator)		
8	3911014	Screw, Round Head #10-24NC x 7/8"	4	
9	4771000	Starwasher #10	4	
10	3311001	Nut #10-24NC	8	
11		Controller Options:	3	
	4640559	Controller (Prior February 1992)		
	4640748	Controller (February 1992 to Present)		
	7009352	Boot (1 Per Assembly)	A/R	
	7012314	Lever Kit (1 Per Assembly)	A/R	
	7012316	Spring, Handle Lock (1 Per Assembly)	A/R	
12	4360209	Breaker, Circuit - 20 Amp	1	
13	4360202	Switch, Toggle - DPDT/MC/CO	3	
14		Switch, Shield Options:	A/R	
	4060087	Shield (Prior to May 1994)		
	4060229	Shield (May 1994 to Present)		

SECTION 4 PLATFORMS

# SECTION 4 PLATFORMS

**FIGURE 4-8. CONSOLE BOX ASSEMBLY - HYDRAULIC CONTROLS (CONTINUED)**

FIG & ITEM #	PART NUMBER	DESCRIPTION	QTY.	REV.
15	3790012	O-Ring	A/R	
16	4360199	Switch, Toggle - SPST	4	
17	2920015	Lamp	1	
18	4360274	Switch, Push Button	2	
19	4360141	Cover, Switch	1	
20	4761000	Lockwasher #10	8	
21	4360200	Switch, Toggle - SPST/MC	1	
22	3300047	Locknut, Conduit	2	
23	4460052	Connector, Strain Relief	2	
24	4460051	Connector, Strain Relief	1	
25	3300048	Locknut, Conduit	1	
26	Not Used			
27	4460263	Strip, Terminal	1	
28	3911012	Screw #10-24NC x 3/4"	4	
29	Not Used			
30	Not Used			
31	Not Used			
32	Not Used			
33	Not Used			
34	3311505	Locknut 5/16"-19NC	4	
35	4751500	Flatwasher 5/16"	8	
36	0641508	Bolt 5/16"-18	NC	4
37	Not Used			
38	0751006	Screw #10-24NC x 3/4"	21	
39	3300177	Nut, Tinnerman	21	
40	Not Used			
41	4060092	Shield, Weatherproof (See Section 10 for Options)	1	
42	4460190	Receptacle, Electrical (See Section 10 for Options)	1	
43	0860038	Box, Electrical	1	
44	4460071	Connector, Strain Relief	1	
45	0960407	Reducer	1	
46	3900294	Screw #10-16NC x 1"	4	
47	Not Used			
48	Not Used			
49	Not Used			
50	Not Used			
51	Not Used			
52	Not Used			
53		Controller Options:	1	
	4640560	Controller (Prior to February 1992)		
	4640749	Controller (February 1992 to Present)		
	7009352	Boot (1 Per Assembly)	A/R	
	7012314	Lever Kit (1 Per Assembly)	A/R	
	7012316	Spring, Handle Lock (1 Per Assembly)	A/R	
54	0641406	Bolt 1/4"-20NC x 3/4"	8	
55	3311401	Nut 1/4"-20NC	20	
56	4751400	Flatwasher 1/4"	16	
57	4761400	Lockwasher 1/4"	12	
58	Not Used			

# SECTION 4 PLATFORMS

**FIGURE 4-8. CONSOLE BOX ASSEMBLY - HYDRAULIC CONTROLS (CONTINUED)**

FIG & ITEM #	PART NUMBER	DESCRIPTION	QTY.	REV.
59	Not Used			
60	Not Used			
61	1320041	Clamp	1	
62	0641409	Bolt 1/4"-20NC x 1 1/8"	4	
63	1260017	Chain	16 in/ 41cm	
64	2820022	Tubing	15 in/ 39cm	
65	0960238	Bushing	1	
66	0960239	Bushing	2	
67	4741000	Washer, Nylon	21	
68	4751000	Flatwasher #10	4	
69	4420037	Tape, Insulation	12 in/ 27cm	
	0250067	<b>CONSOLE BOX ASSEMBLY - MACHINES WITHOUT CAPACITY INDICATOR (VARIABLE PARTS)</b>	Ref.	J
101		Capacity Decal Options:	1	
	3251551	Decal (Prior to May 1994)		
	3252394	Decal (May 1994 to Present)		
	0239229	<b>CONSOLE BOX ASSEMBLY - STANDARD MACHINES WITH CAPACITY INDICATOR AND STANDARD PLATFORMS (VARIABLE PARTS)</b>	Ref.	N
	0250674	<b>CONSOLE BOX ASSEMBLY - CSA MACHINES WITH CAPACITY INDICATOR AND STANDARD PLATFORM (VARIABLE PARTS)</b>	Ref.	H
	0254246	<b>CONSOLE BOX ASSEMBLY - MACHINES WITH CAPACITY INDICATOR AND LOW MOUNT PLATFORM (VARIABLE PARTS)</b>	Ref.	D
101	29600006	Lens, Capacity Indicator	1	

# SECTION 4 PLATFORMS

FIGURE 4-9. CAPACITY INDICATOR INSTALLATION (OPTIONAL)

SECTION 4 PLATFORMS

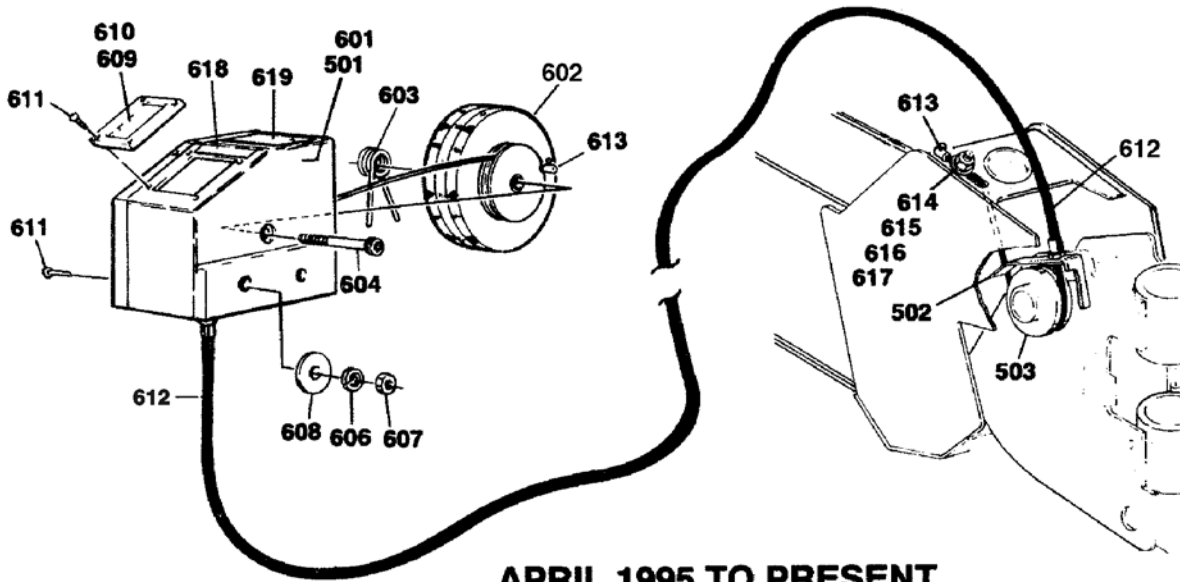

APRIL 1995 TO PRESENT

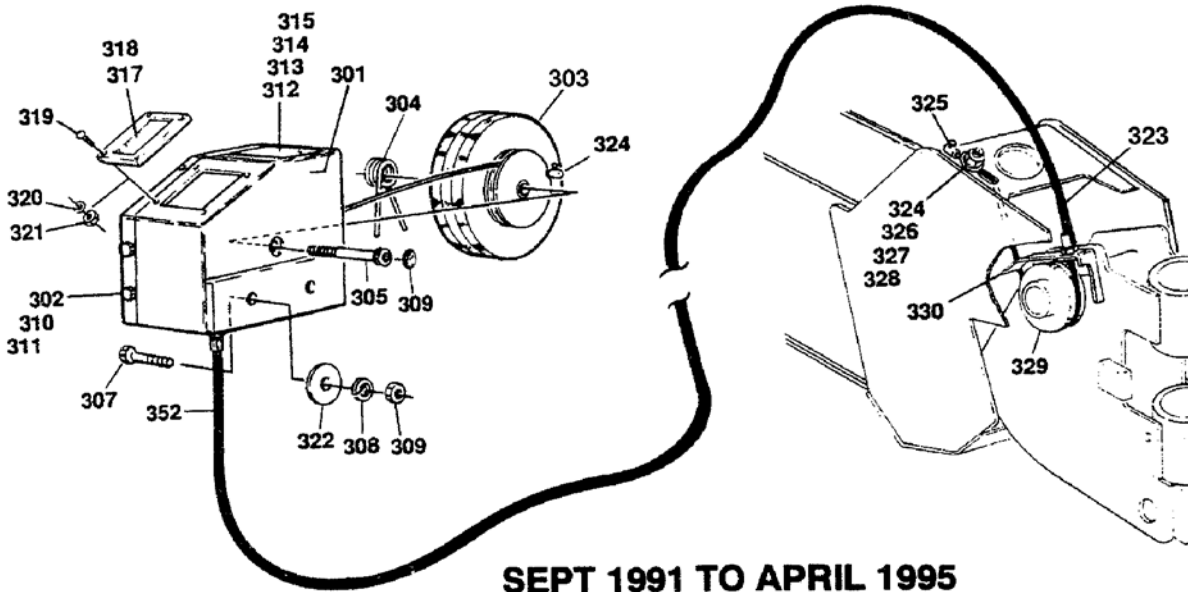

SEPT 1991 TO APRIL 1995

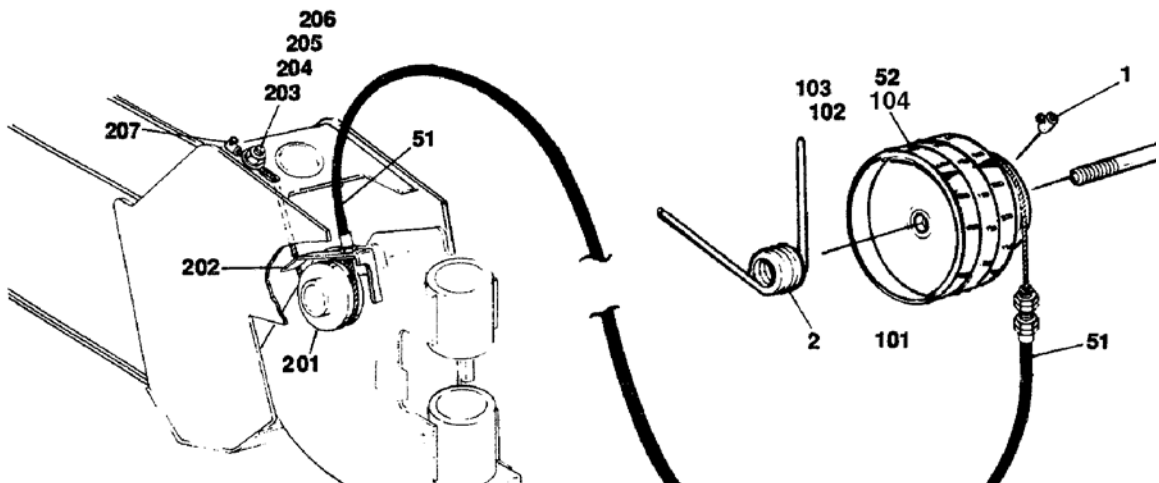



# SECTION 4 PLATFORMS

**FIGURE 4-9. CAPACITY INDICATOR INSTALLATION (OPTIONAL)**

FIG & ITEM #	PART NUMBER	DESCRIPTION	QTY.	REV.
		<b>CAPACITY INDICATOR INSTALLATION (OPTIONAL)</b> <b>Note: Use 1-207 for machines with standard controls built prior to September 1991 and all machines with hydraulic controls. Use 301-403 for machines with standard controls built September 1991 to April 1995. Use 501-619 for machines with standard controls built April 1995 to present.</b>	Ref.	
		<b>GAGE INSTALLATIONS (STANDARD PARTS) (SEE NOTE FOR USAGE)</b>	Ref.	
1	4220044	Stop, Throttle	2	
2	4160058	Spring, Torsion	1	
3	3900111	Screw, Shoulder 3/8"-16NC x 1 3/4"	1	
	0100011	Loctite #242	A/R	
		<b>GAGE INSTALLATIONS (VARIABLE PARTS) (SEE NOTE FOR USAGE)</b>	Ref.	
51		Cable Options:	1	
	1060168	Cable (60H/70H with Racine Prop Valves)		
	1060168	Cable (60H/60H+6/70H with Vickers Prop Valves, with Prop Tele and with Standard Platform)		
	1060369	Cable (60H/60H+6/70H with Vickers Prop Valves, without Prop Tele and with Standard Platforms)		
	1060417	Cable (60H/70H with Vickers Prop Valves and Low Mount Platforms)		
	1060369	Cable (60H+6 without Prop Tele and with Low Mount Platform)		
	1060168	Cable (60H+6 with Prop Tele and with Low Mount Platform)		
52		Capacity Indicator Gage Options (See Items 101-151 for Breakdown)	1	
	2420055	Gage (Domestic/Standard)		
	2420050	Gage (CSA/2:1 Stability)		
	2420055	<b>CAPACITY INDICATOR GAGE ASSEMBLY - DOMESTIC/STANDARD</b>	Ref.	
	2420050	<b>CAPACITY INDICATOR GAGE ASSEMBLY - CSA/2:1 STABILITY</b>	Ref.	
101	2420057	Housing	1	
102	0440042	Bearing, Ball	2	
103	4561774	Tube, Spacer	1	
104		Nameplate - Capacity Options:	1	
	1700503	Domestic/Standard		
	1700502	CSA/2:1 Stability		

# SECTION 4 PLATFORMS

**FIGURE 4-9. CAPACITY INDICATOR INSTALLATION (OPTIONAL) (CONTINUED)**

FIG & ITEM #	PART NUMBER	DESCRIPTION	QTY.	REV.
	0236834	<b>CAPACITY INDICATOR INSTALLATION (SEE NOTE FOR USAGE)</b>	Ref.	C
201	3580092	Pulley	1	
202	1670340	Cover	1	
203	1320109	Cable	1	
204	4751600	Flatwasher 3/8"	3	
205	4761600	Lockwasher 3/8"	1	
206	3321601	Nut 3/8"-24NF	1	
207	4220044	Stop, Throttle	1	
	0252285	<b>CAPACITY INDICATOR INSTALLATION - DOMESTIC STANDARD PLATFORM</b>	Ref.	C
	0252510	<b>CAPACITY INDICATOR INSTALLATION - CSA STANDARD PLATFORM</b>	Ref.	B
	0253437	<b>CAPACITY INDICATOR INSTALLATION - DOMESTIC LOW MOUNT PLATFORM</b>	Ref.	B
	0253438	<b>CAPACITY INDICATOR INSTALLATION - CSA LOW MOUNT PLATFORM</b>	Ref.	C
301	4843851	Box Weldment	1	
302	4843852	Sideplate Weldment	1	
303		Capacity Indicator Gage Options (See Items 401-403 for Breakdown):	1	
	2420055	Gage (Domestic/Standard)		
	2420050	Gage (CSA/2:1 Stability)		
304	4160058	Spring, Torsion	1	
305	3900111	Bolt, Shoulder 3/8"-16NC x 1 3/4"	1	
306	0100011	Loctite #242 9Not Shown)	A/R	
307	0641408	Bolt 1/4"-20NC x 1"	2	
308	4751400	Flatwasher 1/4"	2	
309	3311405	Locknut 1/4" -20NC	2	
310	4761400	Lockwasher 1/4"	4	
311	0641404	Bolt 1/4"-20NC x 1/2"	4	
312		Nameplate Options:	1	
	3252084	Nameplate (Prior to May 1994)		
	3252346	Nameplate (May 1994 to Present)		
313	3300177	Nut, Tinnerman	6	
314	0751006	Screw #10-24NC x 3/8"	6	
315	0100001	Adhesive (Not Shown)	A/R	
316	4420008	Tape, Insulation	24 in/ 61cm	
317	3960251	Gasket	1	
318	2960006	Lens	1	
319	3911014	Screw #10-24NC x 7/8"	4	
320	4771000	Starwasher #10	4	
321	3311001	Nut #10-24NC	4	
322	4740362	Washer, Fender	2	
323		Cable Options:	1	
	1060369	Cable (Standard Platform)		
	1060417	Cable (Low Mount Platform)		

**SECTION 4 PLATFORMS**

# SECTION 4 PLATFORMS

**FIGURE 4-9. CAPACITY INDICATOR INSTALLATION (OPTIONAL) (CONTINUED)**

FIG & ITEM #	PART NUMBER	DESCRIPTION	QTY.	REV.
324	4220044	Stop, Throttle	2	
325	1320109	Clamp, Cable	1	
326	4751600	Flatwasher 3/8"	1	
327	4761600	Lockwasher 3/8"	1	
328	3321601	Nut 3/8"-24NF	1	
329	3580183	Pulley	1	
330	1670340	Cover, Pulley	1	
	2420055	<b>CAPACITY INDICATOR GAGE ASSEMBLY</b>	Ref.	
401	2420057	Housing	1	
402	0440042	Bearing, Ball	2	
403	4561774	Tube, Spacer	1	
	0255729	<b>CAPACITY INDICATOR INSTALLATION - DOMESTIC STANDARD PLATFORM</b>	Ref.	-
	0255730	<b>CAPACITY INDICATOR INSTALLATION - CSA STANDARD PLATFORM</b>	Ref.	-
	0255731	<b>CAPACITY INDICATOR INSTALLATION - 0255732DOMESTIC LOW MOUNT PLATFORM</b>	Ref.	-
	0255732	<b>CAPACITY INDICATOR INSTALLATION - CSA LOW MOUNT PLATFORM</b>	Ref.	-
501		Capacity Indicator Assembly Options (See Items 601-619 for Breakdown):	1	
	0255725	Domestic Standard Platform		
	0255726	CSA Standard Platform		
	0255727	Domestic Low Mount Platform		
	0255728	CSA Low Mount Platform		
502	1670340	Cover	1	
503	3580183	Pulley	1	
	0255725	<b>CAPACITY INDICATOR ASSEMBLY - DOMESTIC STANDARD PLATFORM</b>	Ref.	A
	0255726	<b>CAPACITY INDICATOR ASSEMBLY - CSA STANDARD PLATFORM</b>	Ref.	A
	0255727	<b>CAPACITY INDICATOR ASSEMBLY - DOMESTIC LOW MOUNT PLATFORM</b>	Ref.	A
	0255725	<b>CAPACITY INDICATOR ASSEMBLY - CSA LOW PLATFORM</b>	Ref.	A
601	4845030	Box Assembly	1	
602		Gauge, Capacity Indicator Options:		
	2420055	Domestic	1	
	2420050	CSA	1	
603	4160058	Spring	1	
604	3900111	Bolt, Shoulder	1	
605	0100011	Loctite #242 (Not Shown)	A/R	
606	4751400	Flatwasher 1/4"	2	
607	3311405	Locknut 1/4"-20NC	2	
608	4740362	Washer, Fender	2	

# SECTION 4 PLATFORMS

**FIGURE 4-9. CAPACITY INDICATOR INSTALLATION (OPTIONAL) (CONTINUED)**

FIG & ITEM #	PART NUMBER	DESCRIPTION	QTY.	REV.
609	3960251	Gasket	1	
610	2960006	Lens, Indicator	1	
611	3910812	Screw, Machine #8-32NC x 3/4"	10	
612	Not Used	Cable Options:	1	
	1060369	Standard Platform		
	1060417	Low Mount Platform		
613	4220044	Stop, Throttle	2	
614	1320109	Clamp, Cable	1	
615	4751600	Flatwasher 3/8"	3	
616	4761600	Lockwasher 3/8"	1	
617	3321601	Nut 3/8"-24NC	1	
618	7012662	Decal - Instructions	1	
619	7012672	Decal - Warning	1	

**SECTION 4 PLATFORMS**

# SECTION 4 PLATFORMS

FIGURE 4-9. CAPACITY INDICATOR INSTALLATION (OPTIONAL) (CONTINUED)

FIG & ITEM #	PART NUMBER	DESCRIPTION	QTY.	REV.

**S  
E  
C  
T  
I  
O  
N  
  
4  
  
P  
L  
A  
T  
F  
O  
R  
M  
S**

# SECTION 4 PLATFORMS

FIGURE 4-10. OPTIONAL COMMON PLATFORM MOUNTED COMPONENTS

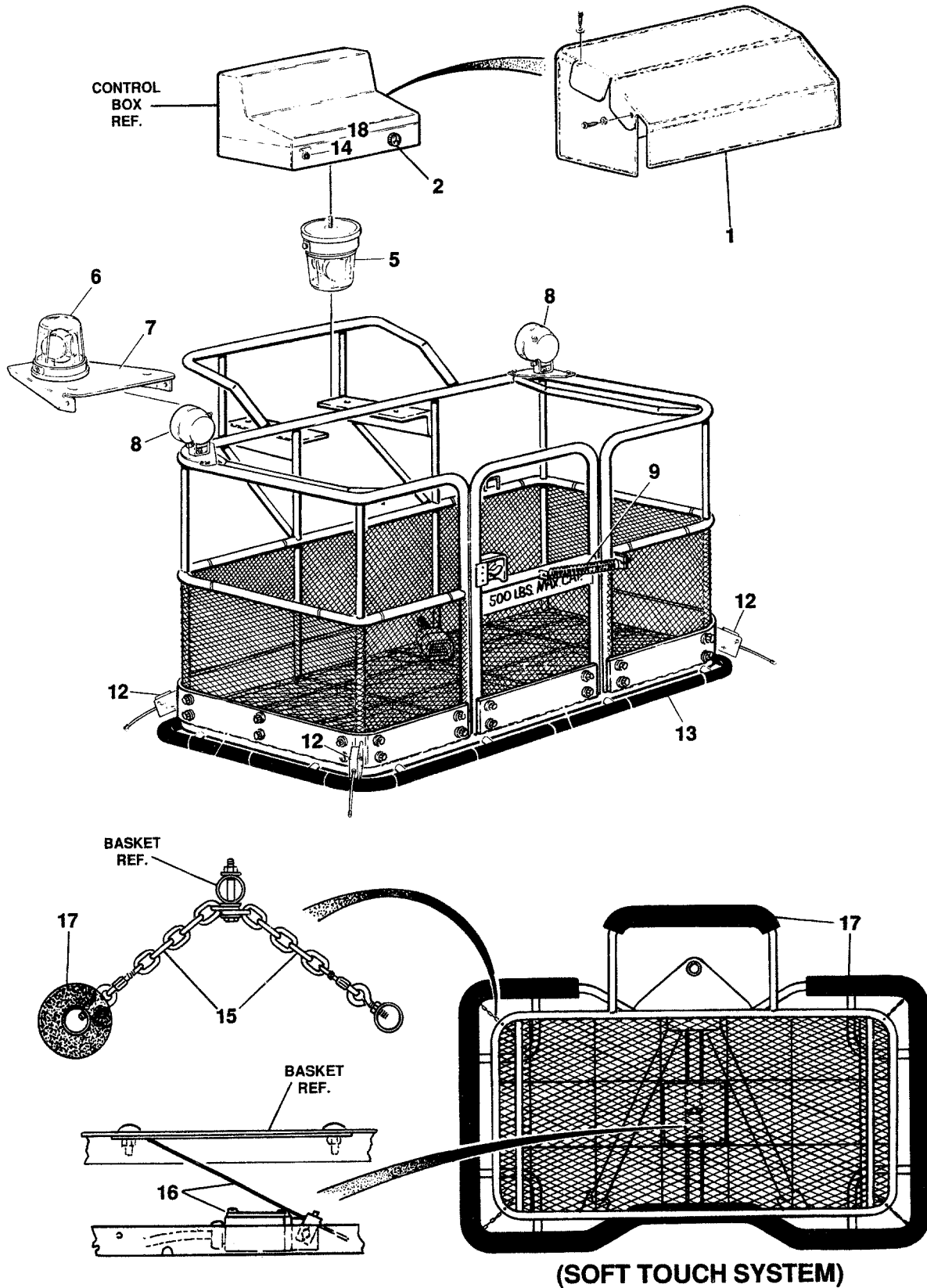

SECTION 4 PLATFORMS

# SECTION 4 PLATFORMS

**FIGURE 4-10. OPTIONAL COMMON PLATFORM MOUNTED COMPONENTS**

FIG & ITEM #	PART NUMBER	DESCRIPTION	QTY.	REV.
		<b>OPTIONAL COMMON PLATFORM MOUNTED COMPONENTS</b>	Ref.	
	0237171/ 0239254	<b>CONSOLE BOX COVER INSTALLATIONS (PRIOR TO SEPTEMBER 1990)</b>	Ref.	A/-
	0252054/ 0231203	<b>CONSOLE BOX COVER INSTALLATIONS (SEPTEMBER 1990 TO PRESENT)</b>	Ref.	2/2
		<b>Note: See Section 10 for Metal Console Covers.</b>	Ref.	
1		Cover Options:	1	
	1670366	Cover (PQ Controllers/Prior to September 1990)	1	
	1670482	Cover (OEM Controllers/Prior to September 1990)		
	1670607	Cover (Black/September 1990 to Present)		
	1670526	Cover (Yellow/September 1990 to Present)		
	0254203/ 0253077	<b>ALARM INSTALLATIONS</b>	Ref.	B/5
2	0140026	Alarm	1	
3	Not Used			
4	Not Used			
		<b>BEACON LIGHT OPTIONS:</b>	Ref.	
5	0252211/ 0252210	Beacon Mounted Under Console (September 1991 to Present)	A/R	3/3
	2920009	Beacon (Red)		
	2920018	Beacon (Amber)		
6	0235980/ 0235981	Beacon Mounted in Front of Console (Prior to September 1991)	A/R	A/A
	2920009	Beacon (Red)		
	2920100	Beacon (Red) (U/L)		
	2920018	Beacon (Amber)		
	2920096	Beacon (Amber) (U/L)		
7	0901449	Bracket, Mounting		
	2900068	<b>WORKLIGHT OPTIONS (PRIOR TO NOVEMBER 1992)</b>	Ref.	F
	0253987	<b>WORKLIGHT OPTIONS (NOVEMBER 1992 TO PRESENT)</b>	Ref.	4
	0254748	<b>WORKLIGHT OPTIONS WITH PADDED PLATFORM</b>	Ref.	2
8	2920013	Floodlight (Prior to November 1992)	2	
	2920111	Halogen Light (November 1992 to Present) (Uses P/N 3536089 Mounting Plate)	2	

# SECTION 4 PLATFORMS

**FIGURE 4-10. OPTIONAL COMMON PLATFORM MOUNTED COMPONENTS (CONTINUED)**

FIG & ITEM #	PART NUMBER	DESCRIPTION	QTY.	REV.
	0250143	<b>SELF-CLOSING GATE INSTALLATION</b>	Ref.	A
9	4160028	Spring	1	
	0900232	Bracket (Door Mounted)	1	
	0901056	Bracket (Platform Mounted)	1	
	4220007	Stop, Door	1	
10	Not Used			
11	Not Used			
		<b>PLATFORM BUMPERS INSTALLATION (WELDED-ON TYPE)</b>	Ref.	
	0250689	<b>3'x5' STANDARD PLATFORM WITH STANDARD CONTROLS</b>	Ref.	C
	0251162	<b>3'x5' STANDARD PLATFORM WITH HYDRAULIC CONTROLS</b>	Ref.	C
	0251035	<b>3'x6' STANDARD PLATFORM</b>	Ref.	C
	0251348	<b>3'x8' STANDARD PLATFORM</b>	Ref.	
	0251349	<b>3'x5' EXTEND-A-REACH PLATFORM</b>	Ref.	
	0251350	<b>3'x6' EXTEND-A-REACH PLATFORM</b>	Ref.	
	0250919	<b>3'x5' LOW MOUNT PLATFORM</b>	Ref.	
	0253462	<b>3'x6' LOW MOUNT PLATFORM</b>	Ref.	A
	0252902	<b>3'x8' LOW MOUNT PLATFORM</b>	Ref.	A
12	4360305	Switch, Proximity - U/L Machines	4	
	4360215	Switch, Proximity - Standard Machines	4	
	4460521	Connector, Strain Relief	4	
13	0940038	Padding, Bumper	A/R	
14	4360274	Switch, Push Button (Override)	1	
	3251596	Nameplate - Override	1	
	3740049	Relay (Not Shown)	1	
		<b>PLATFORM BUMPERS INSTALLATION - SOFT TOUCH SYSTEM (CHAIN MOUNTED TYPE)</b>	Ref.	
	0254463	<b>3'x5' LOW MOUNT PLATFORM</b>	Ref.	6
	0254464	<b>3'x6' LOW MOUNT PLATFORM</b>	Ref.	7
	0254465	<b>3'x8' LOW MOUNT PLATFORM</b>	Ref.	7
15	0630440	Eyebolt	8	
	3010088	Link, Quick	8	
	1260136	Chain	A/R	
16	4360057	Switch, Limit	1	
	0200048	Arm, Actuator	1	
17	0940038	Padding (Bottom Rail)	A/R	
	1670663	Padding (Rail Behind Console Box) (Prior to S/N 44770)	1	
	1670664	Padding (LH Top Rail - 36" x 60" Platform)	1	
	1670715	Padding (LH Top Rail - 36" x 72" Platform)	1	
	1670720	Padding (LH Top Rail - 36" x 96" Platform)	1	
	1670665	Padding (Vertical Rails)	4	
	1670666	Padding (Gate)	1	
	1670667	Padding (RH Top Rail - 36" x 60" Platform)	1	
	1670716	Padding (RH Top Rail - 36" x 72" Platform)	1	



# SECTION 4 PLATFORMS

**FIGURE 4-10. OPTIONAL COMMON PLATFORM MOUNTED COMPONENTS (CONTINUED)**

FIG & ITEM #	PART NUMBER	DESCRIPTION	QTY.	REV.
17 (cont'd)	1670721	Padding (RH Top Rail - 36" x 96" Platform)	1	
	1670671	Padding (LH Mid Rail - 36" x 60" Platform)	1	
	1670717	Padding (LH Mid Rail - 36" x 72" Platform)	1	
	1670722	Padding (LH Mid Rail - 36" x 96" Platform)	1	
	1670717	Padding (LH Mid Rail - 36" x 72" Platform)	1	
	1670722	Padding (LH Mid Rail - 36" x 96" Platform)	1	
	1670672	Padding (RH Mid Rail - 36" x 60" Platform)	1	
	1670718	Padding (RH Mid Rail - 36" x 72" Platform)	1	
	1670723	Padding (RH Mid Rail - 36" x 96" Platform)	1	
	1670673	Padding (Bumper Rail - 36" x 60" Platform)	1	
	1670719	Padding (Bumper Rail - 36" x 72" Platform)	1	
	1670724	Padding (Bumper Rail - 36" x 96" Platform)	1	
	18	4360274	Switch, Push Button	1
3252238		Decal - Soft Touch System	1	

**SECTION 4 PLATFORMS**

# SECTION 4 PLATFORMS

FIGURE 4-10. OPTIONAL COMMON PLATFORM MOUNTED COMPONENTS (CONTINUED)

FIG & ITEM #	PART NUMBER	DESCRIPTION	QTY.	REV.

**S  
E  
C  
T  
I  
O  
N  
  
4  
  
P  
L  
A  
T  
F  
O  
R  
M  
S**

# SECTION 5 CYLINDERS

<b>TABLE OF CONTENTS</b>		
<b>FIGURE</b>	<b>DESCRIPTION</b>	<b>PAGE</b>
5-1	AXLE LOCKOUT CYLINDER ASSEMBLIES (Use With Optional Oscillating Axle) . . . . .	5-2
5-2	BOOM LIFT CYLINDER ASSEMBLIES . . . . .	5-6
5-3	EXTEND-A-REACH LIFT CYLINDER ASSEMBLY . . . . .	5-10
5-4	MASTER CYLINDER ASSEMBLY . . . . .	5-12
5-5	PLATFORM LEVEL CYLINDER ASSEMBLIES (Model 60H & 70H Built Prior to December 1986) . . . . .	5-14
5-6	PLATFORM LEVEL CYLINDER ASSEMBLIES (Model 60H & 70H Built December 1986 to April 1992) . . . . .	5-16
5-7	PLATFORM LEVEL CYLINDER ASSEMBLIES (Model 60H & 70H Built April 1992 to Present) <sup>34</sup> . . . . .	5-18
5-8	SLAVE LEVEL CYLINDER ASSEMBLIES (Model 60H+6 Extend-A-Reach) (Prior to S/N 29914) . . . . .	5-20
5-9	SLAVE LEVEL CYLINDER ASSEMBLIES (Model 60H+6 Extend-A-Reach) (S/N 29914 to Present) . . . . .	5-22
5-10	STEER CYLINDER ASSEMBLIES . . . . .	5-24
5-11	TELESCOPE CYLINDER ASSEMBLY (Model 60H & 60H+6) . . . . .	5-28
5-12	TELESCOPE CYLINDER ASSEMBLIES (Model 70H) . . . . .	5-30
5-13	CYLINDER BELLOWS INSTALLATION (Model 70H) . . . . .	5-34

SECTION 5 CYLINDERS

# SECTION 5 CYLINDERS

FIGURE 5-1. AXLE LOCKOUT CYLINDER ASSEMBLIES (USE WITH OPTIONAL OSCILLATING AXLE)

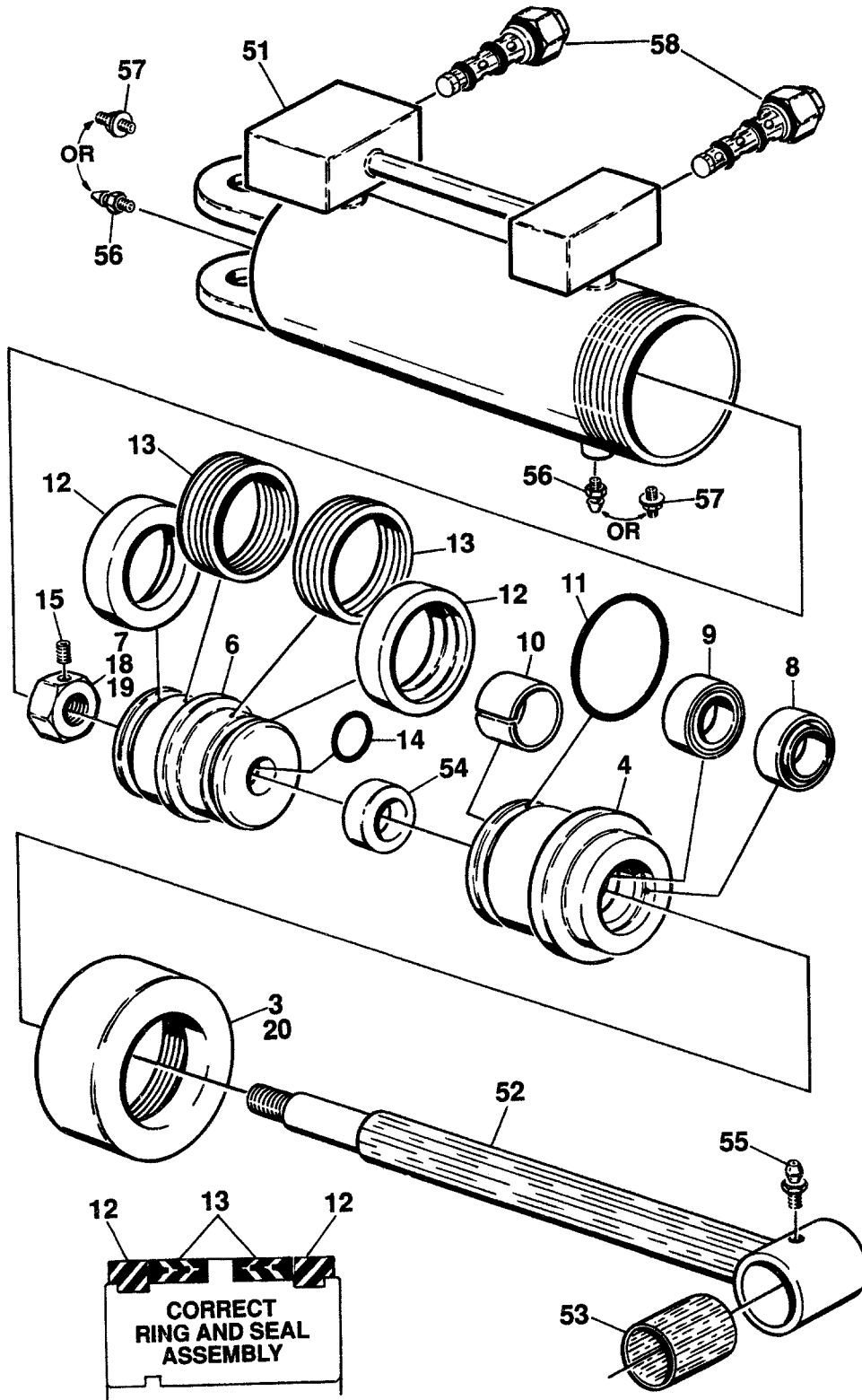

SECTION 5 CYLINDERS

# SECTION 5 CYLINDERS

**FIGURE 5-1. AXLE LOCKOUT CYLINDER ASSEMBLIES (USE WITH OPTIONAL OSCILLATING AXLE)**

FIG & ITEM #	PART NUMBER	DESCRIPTION	QTY.	REV.
		<b>AXLE LOCKOUT CYLINDER ASSEMBLIES (USE WITH OPTIONAL OSCILLATING AXLE)</b>	Ref.	
		<b>AXLE LOCKOUT CYLINDER ASSEMBLY (STANDARD PARTS)</b>	Ref.	
1	Not Used			
2	Not Used			
3	1120094	Retainer	1	
4	1681446	Head	1	
5	Not Used			
6	3480114	Piston	1	
7		Nut Options:	1	
	3300187	Nut (Prior to January 1991)		
	3300273	Nut, Hex (January 1991 to Present)		
8	Kit	Seal, Wiper	1	
9	Kit	Seal, Rod	1	
10	Kit	Ring, Wear	1	
11	Kit	O-Ring	1	
12	Kit	Ring, Lock	2	
13	Kit	Seal, Piston	2	
14	Kit	O-Ring	1	
15		Setscrew Options:	A/R	
	3900139	Setscrew 1/4"-20NC x 1/2" (Prior to January 1991)	2	
	3900170	Setscrew 3/8"-16NC x 3/8" (January 1991 to Present)	1	
16	Not Used			
17	Not Used			
18	0100011	Loctite	A/R	
19	0100038	Primer, Locking	A/R	
20	0100035	Locking Compound	A/R	
	2900366	Seal Kit - Lockout Cylinders (Includes Items 8-14)	1	
	1681568	<b>AXLE LOCKOUT CYLINDER ASSEMBLY (2WD MACHINES BUILT TO MAY 1992) (VARIABLE PARTS)</b>	Ref.	A
	1681569	<b>AXLE LOCKOUT CYLINDER ASSEMBLY (4WD MACHINES BUILT PRIOR TO MAY 1992) (VARIABLE PARTS)</b>	Ref.	B
	1682688	<b>AXLE LOCKOUT CYLINDER ASSEMBLY (MACHINES BUILT MAY 1992 TO PRESENT) (VARIABLE PARTS)</b>	Ref.	A
51		Barrel Assembly Options:	1	
	1681449	2WD Machines Built to May 1992		
	1681444	4WD Machines Built to May 1992		
	1682689	Machines Built May 1992 to Present		

**SECTION 5 CYLINDERS**

# SECTION 5 CYLINDERS

**FIGURE 5-1. AXLE LOCKOUT CYLINDER ASSEMBLIES (USE WITH OPTIONAL OSCILLATING AXLE)**

FIG & ITEM #	PART NUMBER	DESCRIPTION	QTY.	REV.
52	1681450	Rod Assembly Options: 2WD Machines Built to May 1992	1	
	1681447	4WD Machines Built to May 1992		
	1682569	Machines Built May 1992 to Present		
53	Not Required	Bushing, Bronze Options: 2WD Machines Built to May 1992	1	
	Not Required	4WD Machines Built to May 1992		
	0960524	Machines Built May 1992 to Present		
54		Spacer Options:	1	
	4562935	2WD Machines Built to May 1992		
	4562935	4WD Machines Built to May 1992		
55		Machines Built May 1992 to Present	1	
	2160002	Fitting, Grease Options: 2WD Machines Built to May 1992		
	2160002	4WD Machines Built to May 1992		
56	Not Required	Machines Built May 1992 to Present	3	
	4640273	Bleeder Options: 2WD Machines Built to May 1992		
	4640273	4WD Machines Built to May 1992		
57	Not Required	Machines Built May 1992 to Present	3	
	3900175	Setscrew 1/4"-28NF x 3/4"		
	3321401	Nut 1/4"-28NF		
58	3960416	Seal, Thread	2	
	4640509	Valve, Cartridge (Counterbalance)		
	2900792	Seal Kit - 4640509 Valve (1 Per Cartridge)		

SECTION 5 CYLINDERS

# SECTION 5 CYLINDERS

FIGURE 5-1. AXLE LOCKOUT CYLINDER ASSEMBLIES (USE WITH OPTIONAL OSCILLATING AXLE)

FIG & ITEM #	PART NUMBER	DESCRIPTION	QTY.	REV.

**S  
E  
C  
T  
I  
O  
N  
  
5  
  
C  
Y  
L  
I  
N  
D  
E  
R  
S**

# SECTION 5 CYLINDERS

FIGURE 5-2. BOOM LIFT CYLINDER ASSEMBLIES

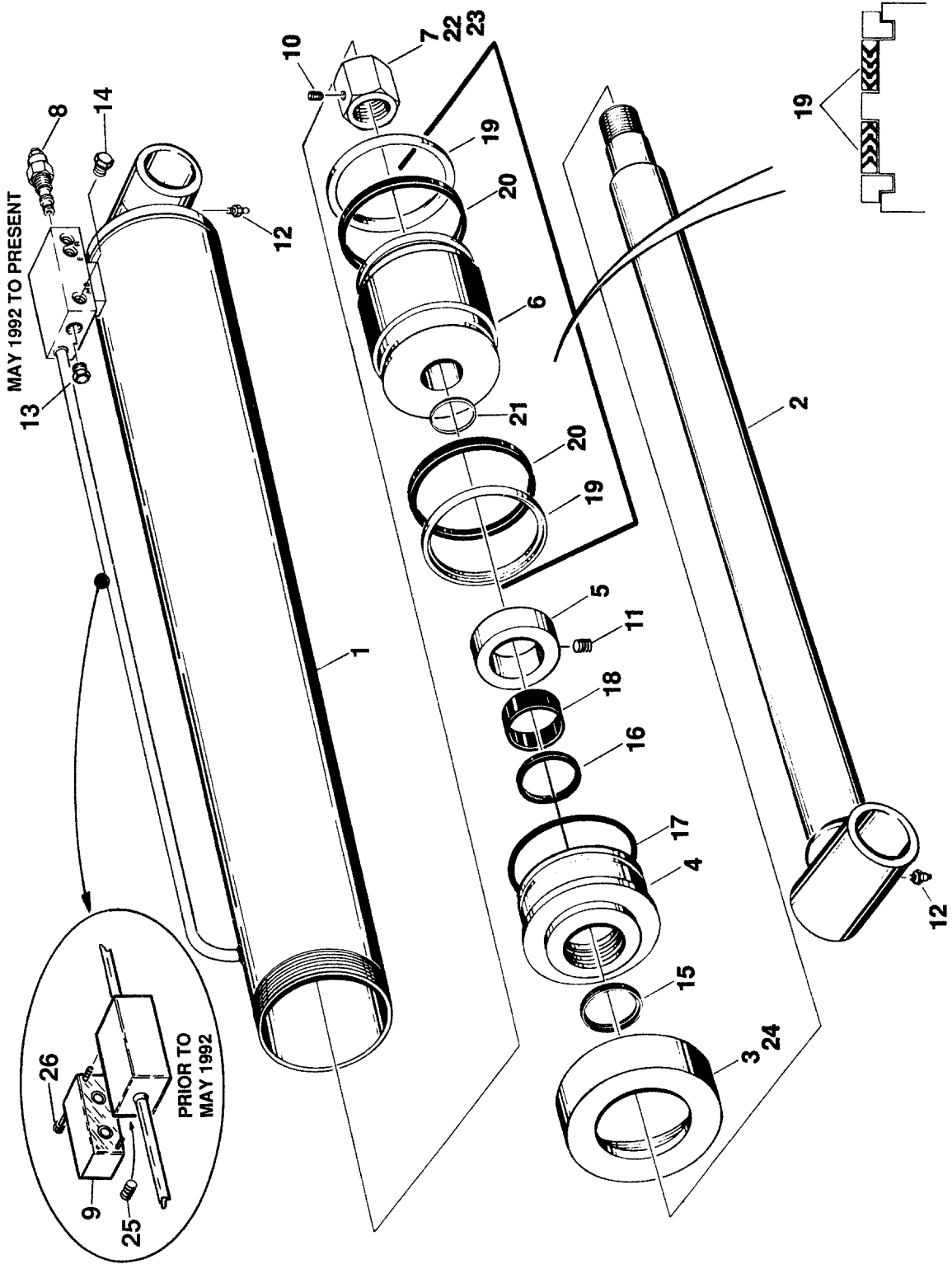

SECTIONS 5 CYLINDERS



# SECTION 5 CYLINDERS

**FIGURE 5-2. BOOM LIFT CYLINDER ASSEMBLIES**

FIG & ITEM #	PART NUMBER	DESCRIPTION	QTY.	REV.
		<b>BOOM LIFT CYLINDER ASSEMBLIES</b>	Ref.	
	1681513	<b>BOOM LIFT CYLINDER ASSEMBLY (MACHINES BUILT PRIOR TO MAY 1992)</b>	Ref.	I
	1682599	<b>BOOM LIFT CYLINDER ASSEMBLY (MACHINES WITH TUV CYLINDERS BUILT MAY 1992 TO PRESENT)</b>	Ref.	B
1		Barrel Assembly Options:	1	
	1680755	Prior to May 1992		
	1682600	May 1992 to Present		
2	1681385	Rod Assembly	1	
3	1120238	Retainer	1	
4	1681298	Head	1	
5	4562646	Spacer	1	
6	3480104	Piston	1	
7		Nut Options:	1	
	3300192	Nut (Prior to January 1991)		
	3300297	Nut, Hex (January 1991 to Present)		
8		Valve Options:	1	
	Not Required	Prior to May 1992		
	4640495	Valve, Cartridge - Holding (May 1992 to Present)		
	2900770	Seal Kit - 4640495 Valve	1	
9		Valve, Block - Holding Options:	1	
	4640181	Prior to May 1992		
	Not Required	May 1992 to Present		
10		Setscrew Options:	A/R	
	3900136	Setscrew 1/2"-13NC x 1/2" (Prior to January 1991)	2	
	3900171	Setscrew 3/8"-16NC x 3/8" (January 1991 to Present)	1	
11	3900136	Setscrew 1/2"-13NC x 1/2"	1	
	0100021	Loctite	A/R	
12	2160002	Fitting, Grease	2	
13		Plug Options:	1	
	Not Required	Prior to May 1992		
	2220887	Plug #10 (May 1992 to Present)		
14		Plug Options:	1	
	Not Required	Prior to May 1992		
	2220883	Plug #4 (May 1992 to Present)		
15	Kit	Seal, Wiper	1	
16	Kit	Seal, Rod	1	
17	Kit	O-Ring	1	
18	Kit	Ring, Wear	1	
19	Kit	Ring, Lock	2	
20	Kit	Seal, Piston	2	
21	Kit	O-Ring	1	
22	0100011	Loctite	A/R	
23	0100038	Primer, Locking	A/R	
24	0100035	Loctite	A/R	
		<b>Note: Items 25 &amp; 26 Machines Built Prior to May 1992 Only.</b>		

# SECTION 5 CYLINDERS

**FIGURE 5-2. BOOM LIFT CYLINDER ASSEMBLIES (CONTINUED)**

FIG & ITEM #	PART NUMBER	DESCRIPTION	QTY.	REV.
56	3900030	Plug, Orifice	1	
57	3931440	Bolt, Socket Head 1/4"-20NC x 2 1/2"	4	
	2900338	Seal Kit - Lift Cylinder Assemblies (Includes Items 15-21)	1	

SECTION 5 CYLINDERS

# SECTION 5 CYLINDERS

FIGURE 5-2. BOOM LIFT CYLINDER ASSEMBLIES (CONTINUED)

FIG & ITEM #	PART NUMBER	DESCRIPTION	QTY.	REV.

**S  
E  
C  
T  
I  
O  
N  
  
5  
  
C  
Y  
L  
I  
N  
D  
E  
R  
S**

# SECTION 5 CYLINDERS

FIGURE 5-3. EXTEND-A-REACH LIFT CYLINDER ASSEMBLY (60H+6 ONLY)

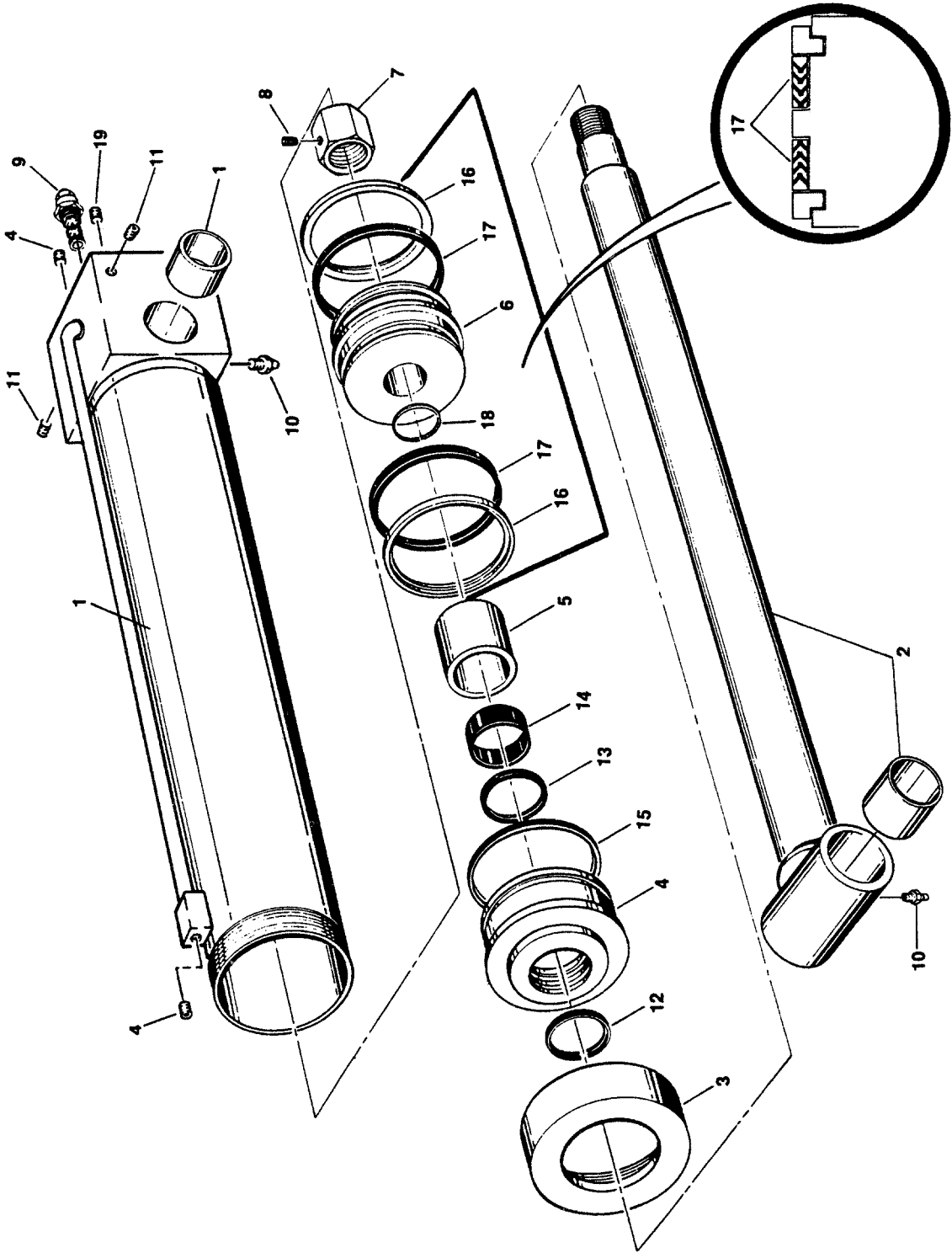

SECTION 5 CYLINDERS

# SECTION 5 CYLINDERS

**FIGURE 5-3. EXTEND-A-REACH LIFT CYLINDER ASSEMBLY (60H+6 ONLY)**

FIG & ITEM #	PART NUMBER	DESCRIPTION	QTY.	REV.
	1681730	<b>EXTEND-A-REACH LIFT CYLINDER ASSEMBLY (60H+6 ONLY)</b>	Ref.	G
1	1681731	Barrel Weldment	1	
	0961185	Bushing, Bronze	2	
2	1681732	Rod Weldment	1	
	0961024'	Bushing, Bronze	2	
3	1120108	Retainer	1	
4	1681283	Head	1	
5	4563577	Spacer	1	
6	3480126	Piston	1	
7	3300278	Nut	1	
8	3900170	Setscrew 3/8"-16NC x 3/8"	1	
9		Cartridge, Holding Valve Options:	1	
	4640495	Cartridge, Holding Valve (Prior to August 1995)		
	2900770	Seal Kit - 4640495 Valve	1	
	4640771	Cartridge, Holding Valve (August 1995 to Present)		
10	2160002	Fitting, Grease (Prior to June 1994)	2	
11	2200221	Plug, Pipe 1/8" NPT	A/R	
12	Kit	Wiper, Rod	1	
13	Kit	Seal, Rod	1	
14	Kit	Ring, Wear	1	
15	Kit	O-Ring	1	
16	Kit	Ring, Guide	2	
17	Kit	Ring, Lock	2	
18	Kit	O-Ring	1	
19	2200222	Plug, Pipe 1/4" NPT	2	
		-----		
	0100020	Sealant, Pipe	A/R	
	0100011	Loctite #242	A/R	
	0100038	Primer, Locking	A/R	
	0100035	Loctite #222	A/R	
		-----		
	2901113	Seal Kit (Includes Items 12-18)	1	

**SECTION 5 CYLINDERS**

# SECTION 5 CYLINDERS

FIGURE 5-4. MASTER CYLINDER ASSEMBLY

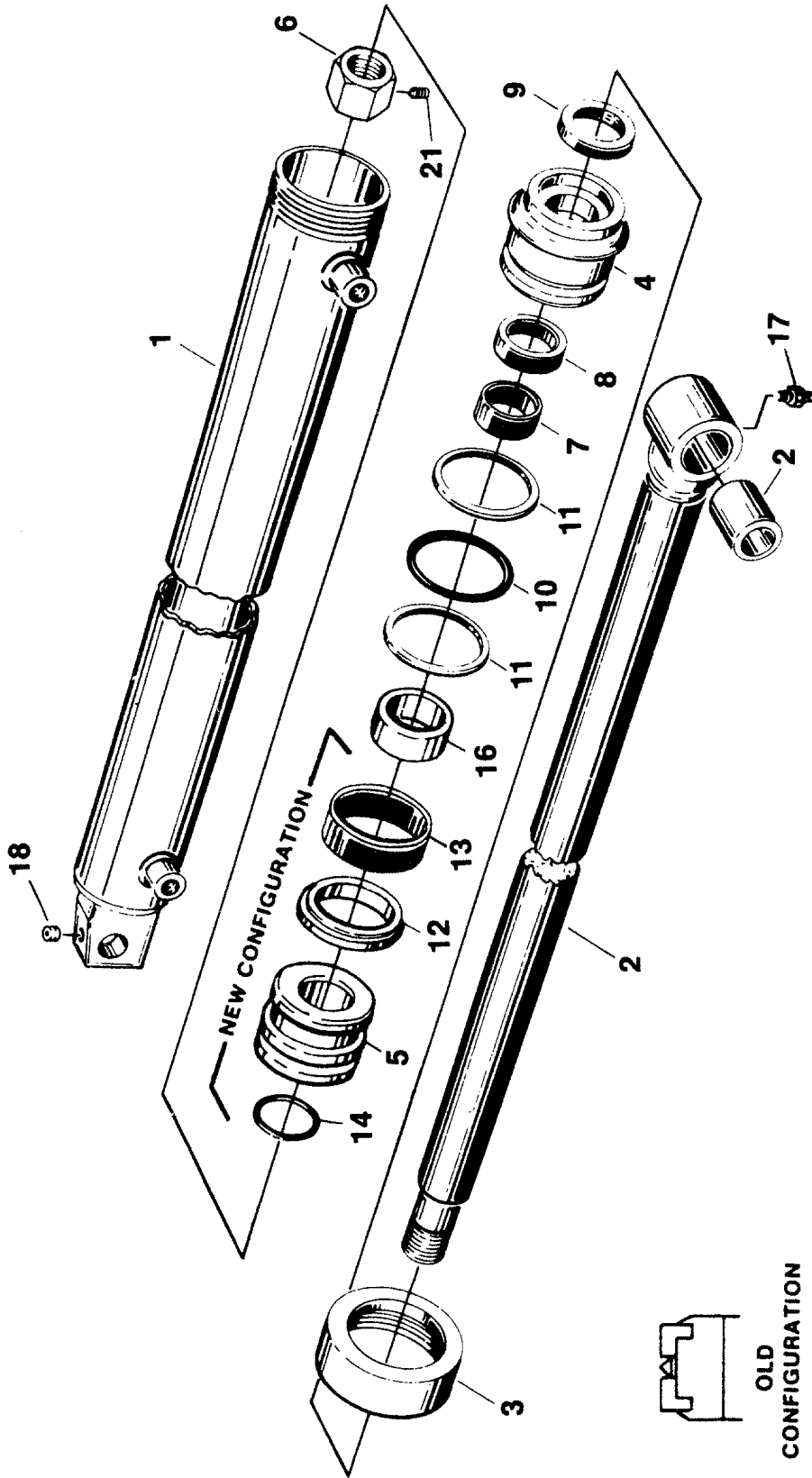

**NOTE: THIS PISTON/SEAL CONFIGURATION NO LONGER AVAILABLE. IF EQUIPPED, NEW PISTON AND SEAL KIT MUST BE ORDERED FOR REPAIR.**

# SECTION 5 CYLINDERS

**FIGURE 5-4. MASTER CYLINDER ASSEMBLY**

FIG & ITEM #	PART NUMBER	DESCRIPTION	QTY.	REV.
	1681580	<b>MASTER CYLINDER ASSEMBLY</b>	Ref.	F
1	1681490	Barrel Weldment	1	
2	1681488	Rod Weldment	1	
	0960097	Bushing, Bronze	1	
3	1120179	Retainer	1	
4	1680892	Head	1	
5	3480120	Piston	1	
6	3300272	Nut	1	
7	Kit	Ring, Wear	1	
8	Kit	Z-Seal	1	
9	Kit	Wiper, Rod	1	
10	Kit	O-Ring	1	
11	Kit	Ring, Back-Up	2	
12	Kit	Seal, Piston	1	
13	Kit	Ring, Wear	1	
14	Kit	O-Ring	1	
15	Not Used			
16	4563031	Tube, Spacer	1	
17	2160002	Fitting, Grease	1	
18	2200201	Plug, Pipe 1/8" NPT	1	
19	Not Used			
20	Not Used			
21	3900170	Setscrew 3/8"-16NC x 3/8"	1	
		-----		
	0100011	Loctite #242	A/R	
	0100038	Primer, Locking	A/R	
	0100035	Loctite #222	A/R	
		-----		
	2900381	Seal Kit (Includes items 7-14)	1	

**SECTION 5 CYLINDERS**

# SECTION 5 CYLINDERS

FIGURE 5-5. PLATFORM LEVEL CYLINDER ASSEMBLIES (MODEL 60H AND 70H BUILT PRIOR TO DECEMBER 1986)

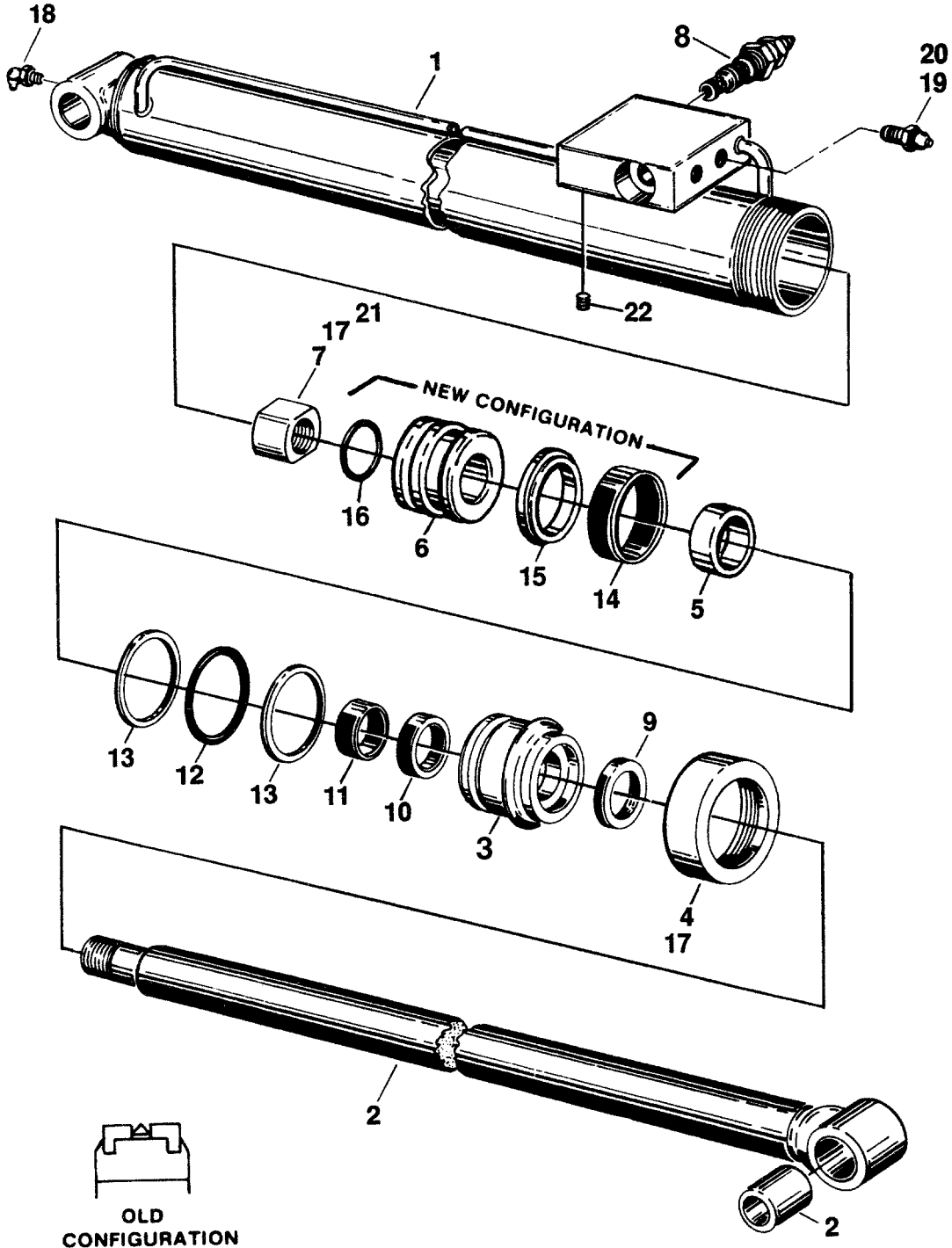

**NOTE: THIS PISTON/SEAL CONFIGURATION NO LONGER AVAILABLE. IF EQUIPPED, NEW PISTON AND SEAL KIT MUST BE ORDERED FOR REPAIR.**

SECTION 5 CYLINDERS



# SECTION 5 CYLINDERS

**FIGURE 5-5. PLATFORM LEVEL CYLINDER ASSEMBLIES (MODEL 60H AND 70H BUILT PRIOR TO DECEMBER 1986)**

FIG & ITEM #	PART NUMBER	DESCRIPTION	QTY.	REV.
		<b>PLATFORM LEVEL CYLINDER ASSEMBLIES</b>	Ref.	
	1681518	<b>PRIOR TO NOVEMBER 1984</b>	Ref.	C
	1681548	<b>NOVEMBER 1984 TO DECEMBER 1986</b>	Ref.	F
1		Barrel Assembly Options:	1	
	1680722	Prior to November 1984		
	1680731	November 1984 to December 1986		
2	16801331	Rod Assembly	1	
	0960097	Bushing	1	
3		Head Options:	1	
	1680892	Prior to November 1984		
	1681635	November 1984 to December 1986		
4	1120179	Retainer	1	
5	1440142	Spacer	1	
6		Piston Options:	1	
	Not Available	Piston (Prior to Mid 1989) (See Note Illustration Page)		
	3480120	Piston (Mid 1989 to December 1986)		
7	3300101	Nut	1	
8		Valve, Cartridge Options:	A/R	
	4640269	Valve, Cartridge (Prior to November 1984)	1	
	4640495	Valve, Cartridge (November 1984 to December 1986)	2	
	2900770	Seal Kit - 4640495 Valve (1 Per Cartridge)	2	
9	Kit	Seal, Wiper	1	
10	Kit	Seal, Rod	1	
11	Kit	Ring, Wear	1	
12	Kit	O-Ring	1	
13	Kit	Ring, Back-up	2	
14	Kit	Ring, Wear	1	
15	Kit	Seal, Piston	1	
16	Kit	O-Ring	1	
17	0100011	Loctite #242	A/R	
18	2160001	Fitting, Grease - 90°	1	
19	2200213	Plug, Pipe - 3/8"	2	
20	0100020	Sealant, Pipe	A/R	
21	0100021	Primer, Locking	A/R	
22	2200201	Plug, Pipe 1/8"	2	
		-----		
	2901119	Seal Kit - 1681518 Cylinder (Includes Items 9-16)	1	
	2901120	Seal Kit - 1681548 Cylinder (Includes Items 9-16)	1	

SECTION 5 CYLINDERS

# SECTION 5 CYLINDERS

FIGURE 5-6. PLATFORM LEVEL CYLINDER ASSEMBLIES (MODEL 60H AND 70H BUILT DECEMBER 1986 TO APRIL 1992)

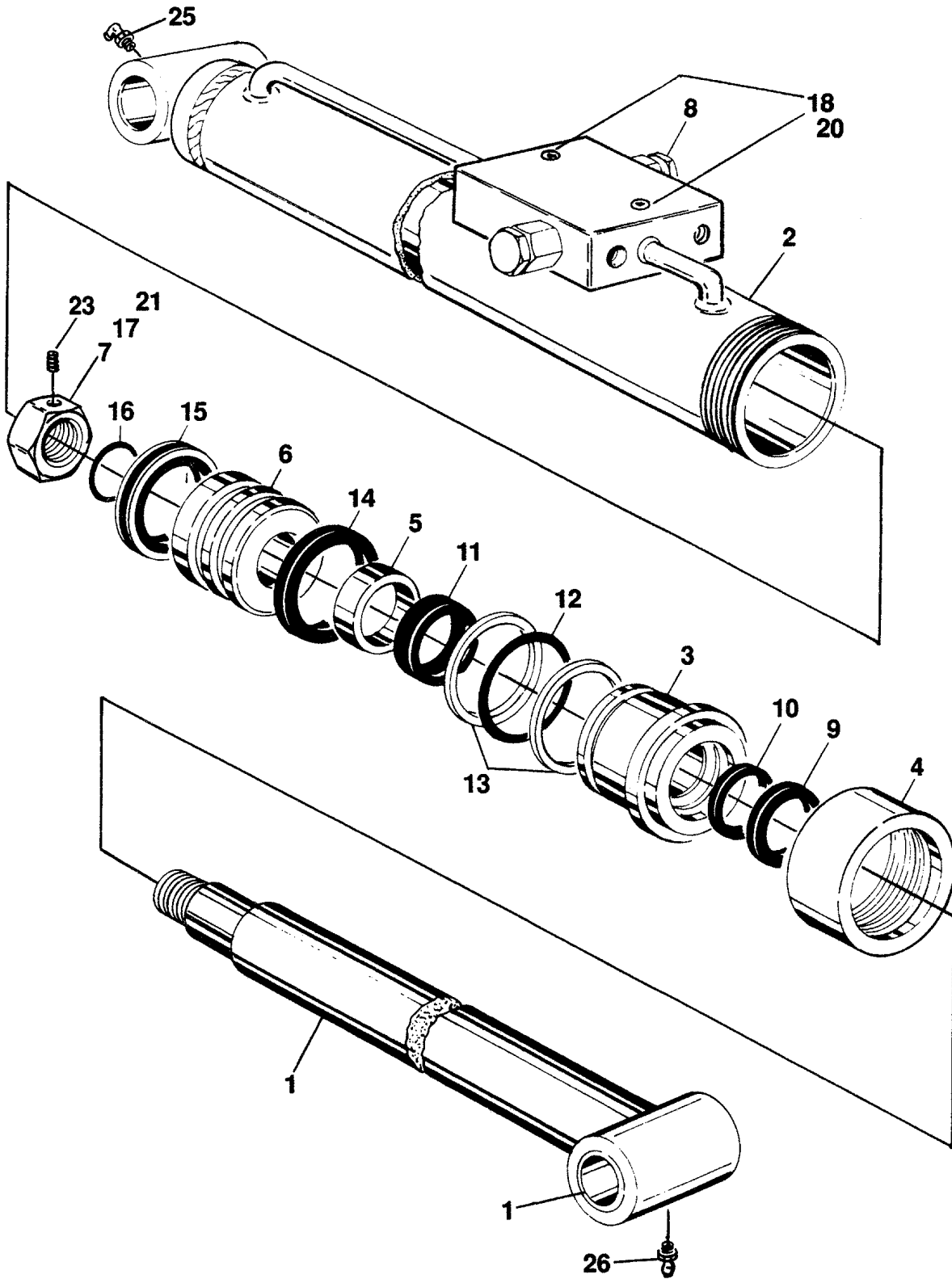

SECTION 5 CYLINDERS

# SECTION 5 CYLINDERS

**FIGURE 5-6. PLATFORM LEVEL CYLINDER ASSEMBLIES (MODEL 60H AND 70H BUILT DECEMBER 1986 TO APRIL 1992)**

FIG & ITEM #	PART NUMBER	DESCRIPTION	QTY.	REV.
		<b>PLATFORM LEVEL CYLINDER ASSEMBLIES (MODEL 60H AND 70H BUILT DECEMBER 1986 TO APRIL 1992)</b>	Ref.	
	1681722	<b>PLATFORM LEVEL CYLINDER ASSEMBLY</b>	Ref.	D
1	1681331	Rod Assembly	1	
	0960097	Bushing, Bronze	1	
2	1681721	Barrel Assembly	1	
3	1680892	Head	1	
4	1120179	Retainer	1	
5	1440142	Spacer	1	
6	3480120	Piston	1	
7		Nut Options:	1	
	3300101	Nut (Prior to January 1991)		
	3300272	Nut, hex (January 1991 to April 1992)		
8	4640509	Valve, Cartridge	2	
	2900792	Seal Kit - 4640509 Valve	2	
9	Kit	Seal, Wiper	1	
10	Kit	Seal, Rod	1	
11	Kit	Ring, Wear	1	
12	Kit	O-Ring	1	
13	Kit	Ring, Back-up	2	
14	Kit	Ring, Wear	1	
15	Kit	Seal, Piston	1	
16	Kit	O-Ring	1	
17	0100011	Loctite #242	A/R	
18	2200201	Plug 1/8"	2	
19	2200202	Plug 1/4"	2	
20	0100020	Sealant, Thread	A/R	
21	0100038	Primer, Locking	A/R	
22	Not Used			
23	3900170	Setscrew 3/8"-16NC x 3/8"	1	
24	0100035	Locking Compound	A/R	
25	2160001	Fitting, Grease - 90°	1	
26	2160002	Fitting, Grease	1	
	2900381	Seal Kit - 1681722 Cylinder (Includes Items 9-16)	1	

SECTION 5 CYLINDERS

# SECTION 5 CYLINDERS

FIGURE 5-7. PLATFORM LEVEL CYLINDER ASSEMBLIES (MODEL 60H AND 70H BUILT APRIL 1992 TO PRESENT)

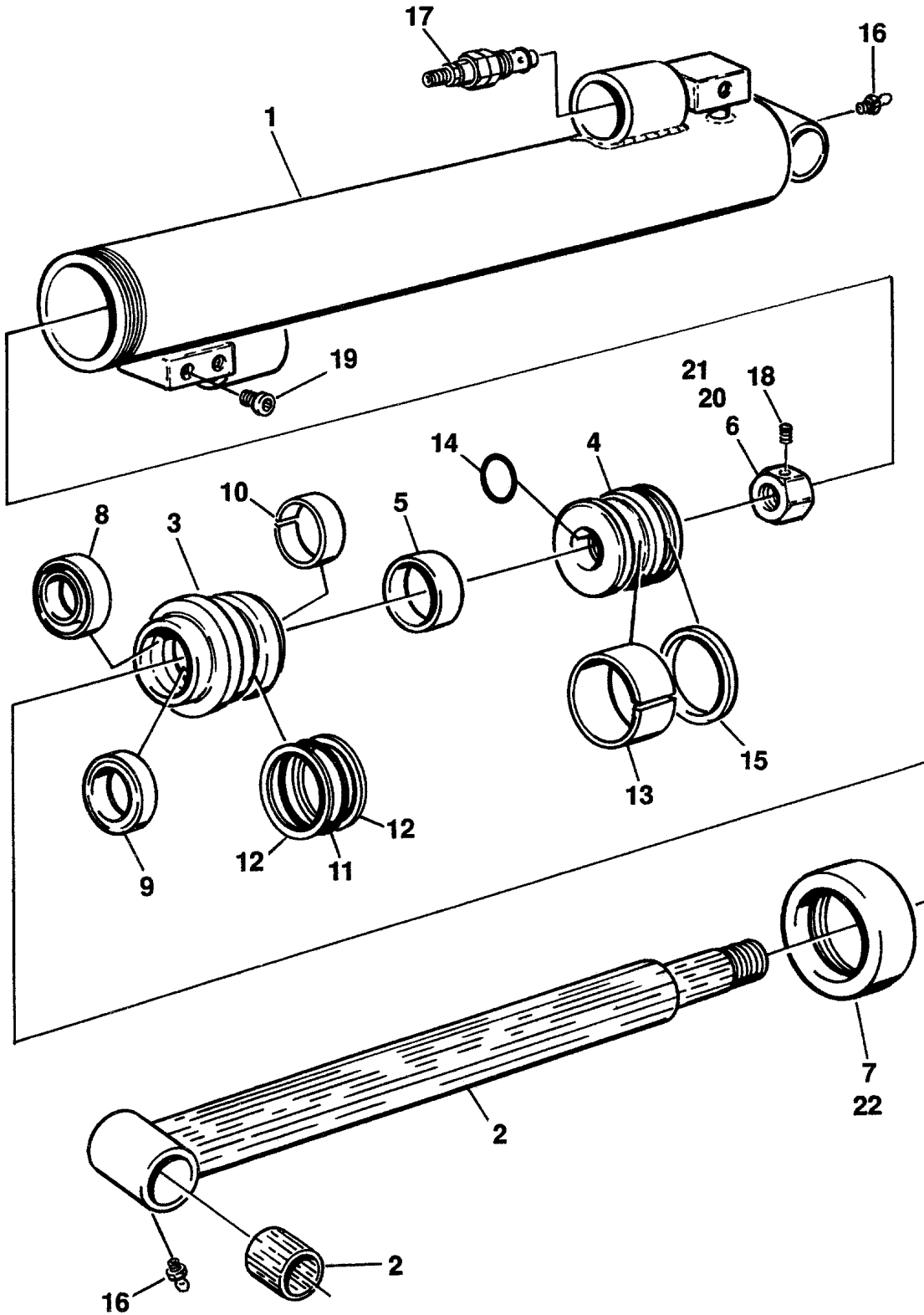

SECTION 5 CYLINDERS

# SECTION 5 CYLINDERS

**FIGURE 5-7. PLATFORM LEVEL CYLINDER ASSEMBLIES (MODEL 60H AND 70H BUILT APRIL 1992 TO PRESENT)**

FIG & ITEM #	PART NUMBER	DESCRIPTION	QTY.	REV.
		<b>PLATFORM LEVEL CYLINDER ASSEMBLY</b>	Ref.	
	1682602	<b>Prior to S/N 33111</b>	Ref.	B
	1683534	<b>S/N 33111 to Present</b>	Ref.	1
1		Barrel Assembly Options:	1	
	1682603	Prior to S/N 33111		
	1683533	S/N 33111 to Present		
2	1681331	Rod Assembly	1	
	0960097	Bushing	1	
3	1680892	Head	1	
4	3480120	Piston	1	
5	4564046	Spacer	1	
6	3300272	Nut	1	
7	1120179	Retainer	1	
8	Kit	Seal, Wiper	1	
9	Kit	Seal, Rod	1	
10	Kit	Ring, Wear	1	
11	Kit	O-Ring	1	
12	Kit	Ring, Back-up	2	
13	Kit	Ring, Wear	1	
14	Kit	O-Ring	1	
15	Kit	Seal, Piston	1	
16	2160002	Fitting, Grease	2	
17	4640634	Valve, Cartridge - Holding	2	
	2900770	Seal Kit - 4640634 Valve (1 Per Assembly)	1	
18	3900170	Setscrew 3/8"-16NC x 3/8"	1	
19	2220885	Plug, Socket Head #6	2	
20	0100011	Loctite #242	A/R	
21	0100038	Primer, Locking	A/R	
22	0100035	Loctite #222	A/R	
		-----		
	2900381	Seal Kit - (Includes Items 8-15)	1	

# SECTION 5 CYLINDERS

FIGURE 5-8. SLAVE LEVEL CYLINDER ASSEMBLIES (MODEL 60H+6 EXTEND-A-REACH) (PRIOR TO S/N 29914)

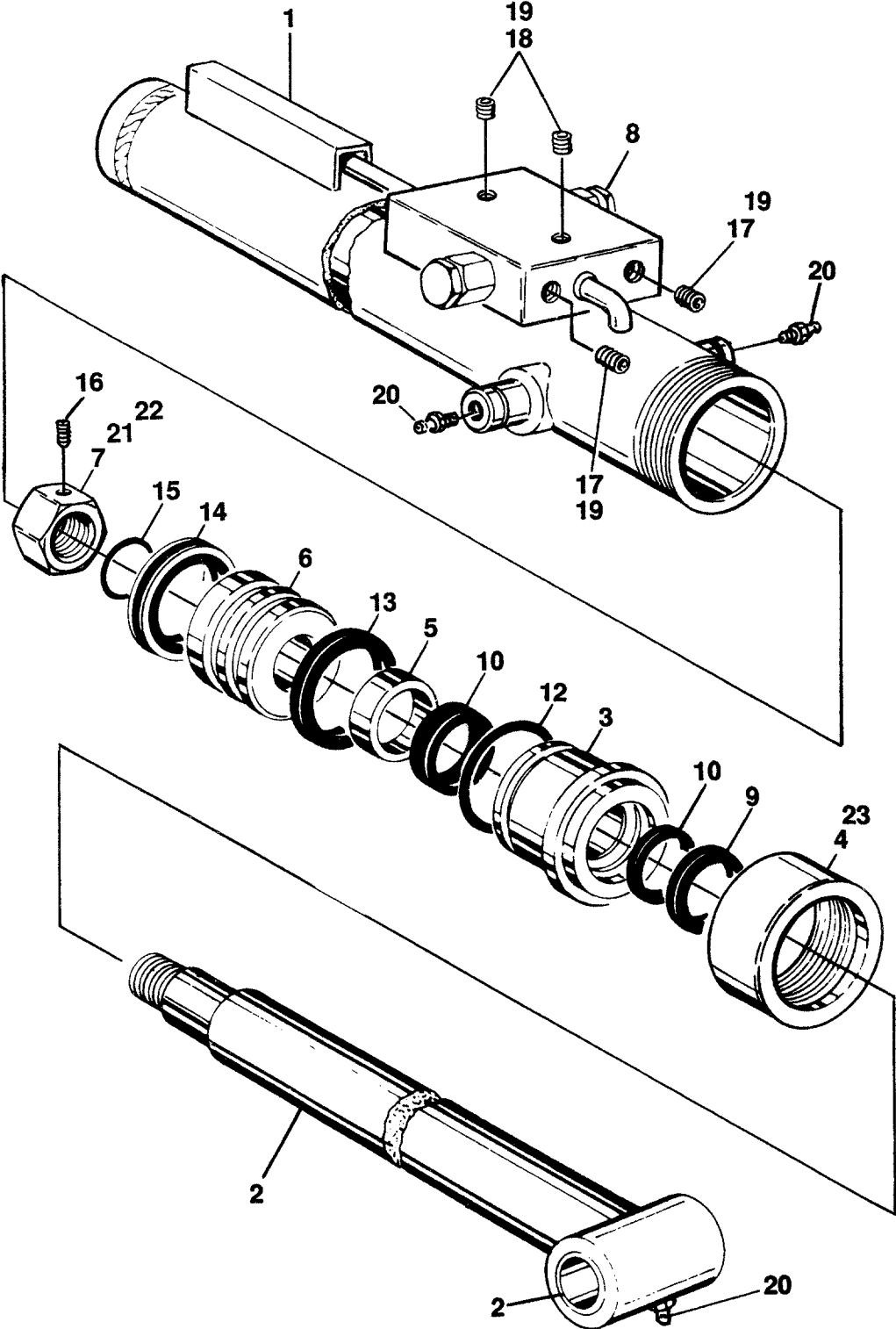

SECTION 5 CYLINDERS

# SECTION 5 CYLINDERS

**FIGURE 5-8. SLAVE LEVEL CYLINDER ASSEMBLIES (MODEL 60H+6 EXTEND-A-REACH) (PRIOR TO S/N 29914)**

FIG & ITEM #	PART NUMBER	DESCRIPTION	QTY.	REV.
		<b>SLAVE LEVEL ASSEMBLIES</b>	Ref.	
	1681791	<b>PRIOR TO FEBRUARY 1991</b>	Ref.	F
	1682459	<b>FEBRUARY 1991 TO S/N 29914</b>	Ref.	A
1		Barrel Assembly Options:	1	
	1681796	Prior to February 1991		
	1682460	February 1991 to S/N 29914		
2	1681797	Rod Assembly	1	
	0961182	Bushing, Bronze	2	
3	1681792	Head	1	
4	1120305	Retainer	1	
5	4563657	Spacer	1	
6	3480124	Piston	1	
7		Nut Options:	1	
	3300234	Nut (Prior to January 1991)		
	3300276	Nut, Hex (January 1991 to S/N 29914)		
8	4640509	Valve, Cartridge - Holding	2	
	2900792	Seal Kit - 4640509 Valve (1 Per Cartridge)	2	
9	Kit	Seal, Wiper	1	
10	Kit	Seal, Rod	1	
11	Kit	Ring, Wear	1	
12	Kit	O-Ring	1	
13	Kit	Ring, Wear	1	
14	Kit	T-Seal	1	
15	Kit	O-Ring	1	
16		Setscrew Options:	A/R	
	3951403	Setscrew 1/4"-20NC x 3/8"	2	
	3900170	Setscrew 3/8"-16NC x 3/8"	1	
17	2200213	Plug, Pipe 1/4"	2	
18	2200201	Plug, Pipe 1/8"	2	
19	0100020	Sealant, Thread	A/R	
20	2160002	Fitting, Grease	3	
21	0100011	Loctite #242	A/R	
22	0100038	Primer, Locking	A/R	
23	0100035	Loctite #222	A/R	
		-----		
	2900394	Seal Kit - Cylinder (Includes Items 9-15)	1	

**SECTION 5 CYLINDERS**

# SECTION 5 CYLINDERS

FIGURE 5-9. SLAVE LEVEL CYLINDER ASSEMBLIES (MODEL 60H+6 EXTEND-A-REACH) (S/N 29914 TO PRESENT)

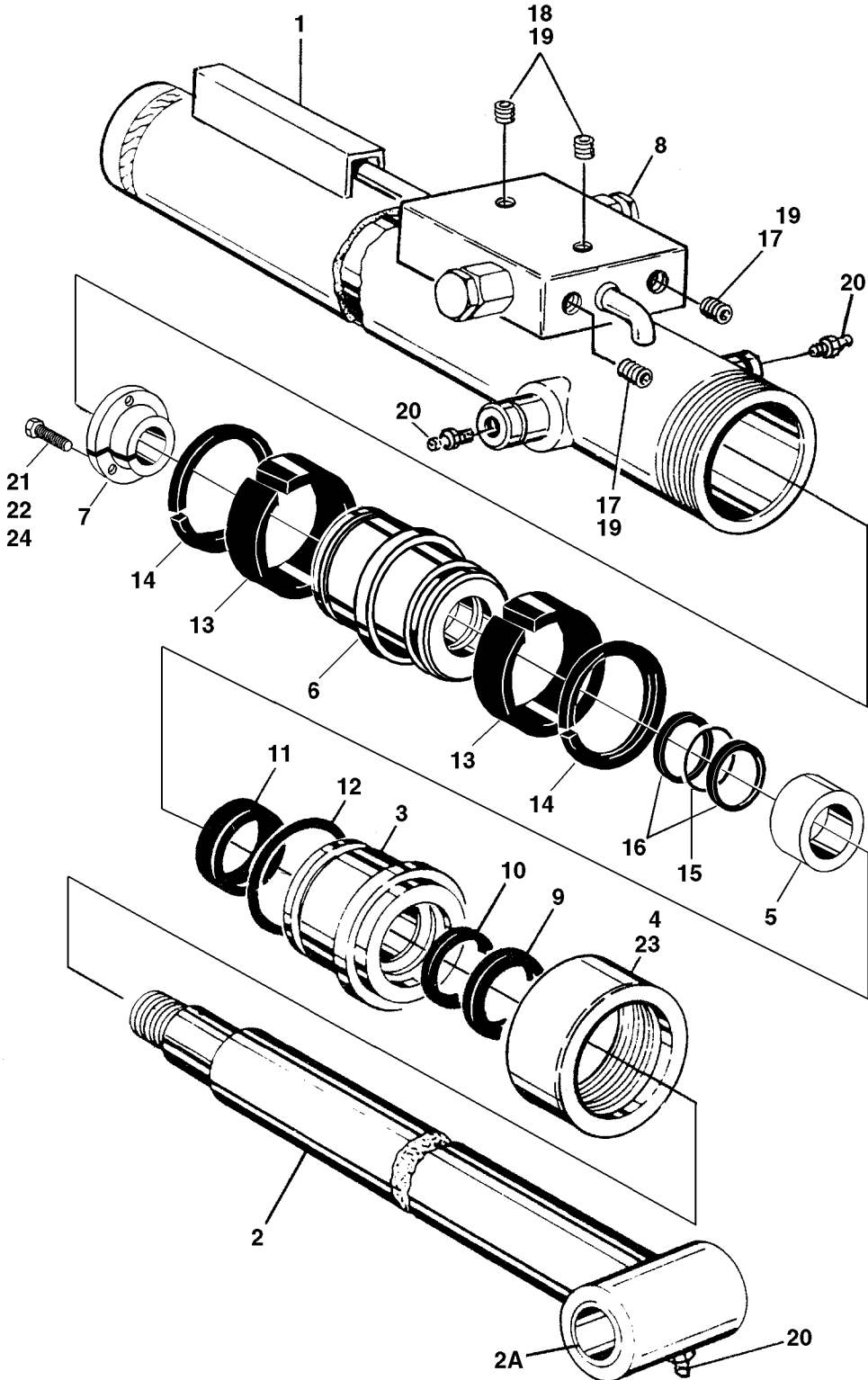

SECTION 5 CYLINDERS



# SECTION 5 CYLINDERS

**FIGURE 5-9. SLAVE LEVEL CYLINDER ASSEMBLIES (MODEL 60H+6 EXTEND-A-REACH) (S/N 29914 TO PRESENT)**

FIG & ITEM #	PART NUMBER	DESCRIPTION	QTY.	REV.
	1683494	<b>SLAVE LEVEL CYLINDER ASSEMBLY</b>	Ref.	2
1	1683495	Barrel Assembly	1	
2	1683497	Rod Assembly	1	
2A	0961182	Bushing, Bronze	2	
3	1681792	Head	1	
4	1120305	Retainer	1	
5	4563657	Spacer	1	
6	3480188	Piston	1	
7	0961894	Bushing, Tapered	1	
8	4640509	Valve, Cartridge - Holding	2	
	2900792	Seal Kit - 4640509 Valve (1 Per Cartridge)	2	
9	Kit	Seal, Wiper	1	
10	Kit	Seal, Rod	1	
11	Kit	Ring, Wear	1	
12	Kit	O-Ring	1	
13	Kit	Ring, Wear	1	
14	Kit	T-Seal	1	
15	Kit	O-Ring	1	
16	Kit	Ring Back-up	1	
17	2200213	Plug, Pipe 1/4"	2	
18	2200201	Plug, Pipe 1/8"	2	
19	0100020	Sealant, Thread	A/R	
20	2160002	Fitting, Grease	3	
21	0100011	Loctite #242 (Prior to S/N 44769)	A/R	
22	0100038	Primer, Locking (Prior to S/N 44769)	A/R	
23	0100035	Loctite #222	A/R	
24		Bolt Options:	3	
	0641408	Bolt 1/4-20 NC x 1" (Prior to S/N 44769)		
	0630535	Screw, Socket Head 1/4"-20NC x 1 1/8" (S/N 44769 to Present)		
	2901480	Seal Kit - Cylinder (Includes Items 9-16)	1	

**SECTION 5 CYLINDERS**

# SECTION 5 CYLINDERS

FIGURE 5-10. STEER CYLINDER ASSEMBLIES

SECTION 5 CYLINDERS

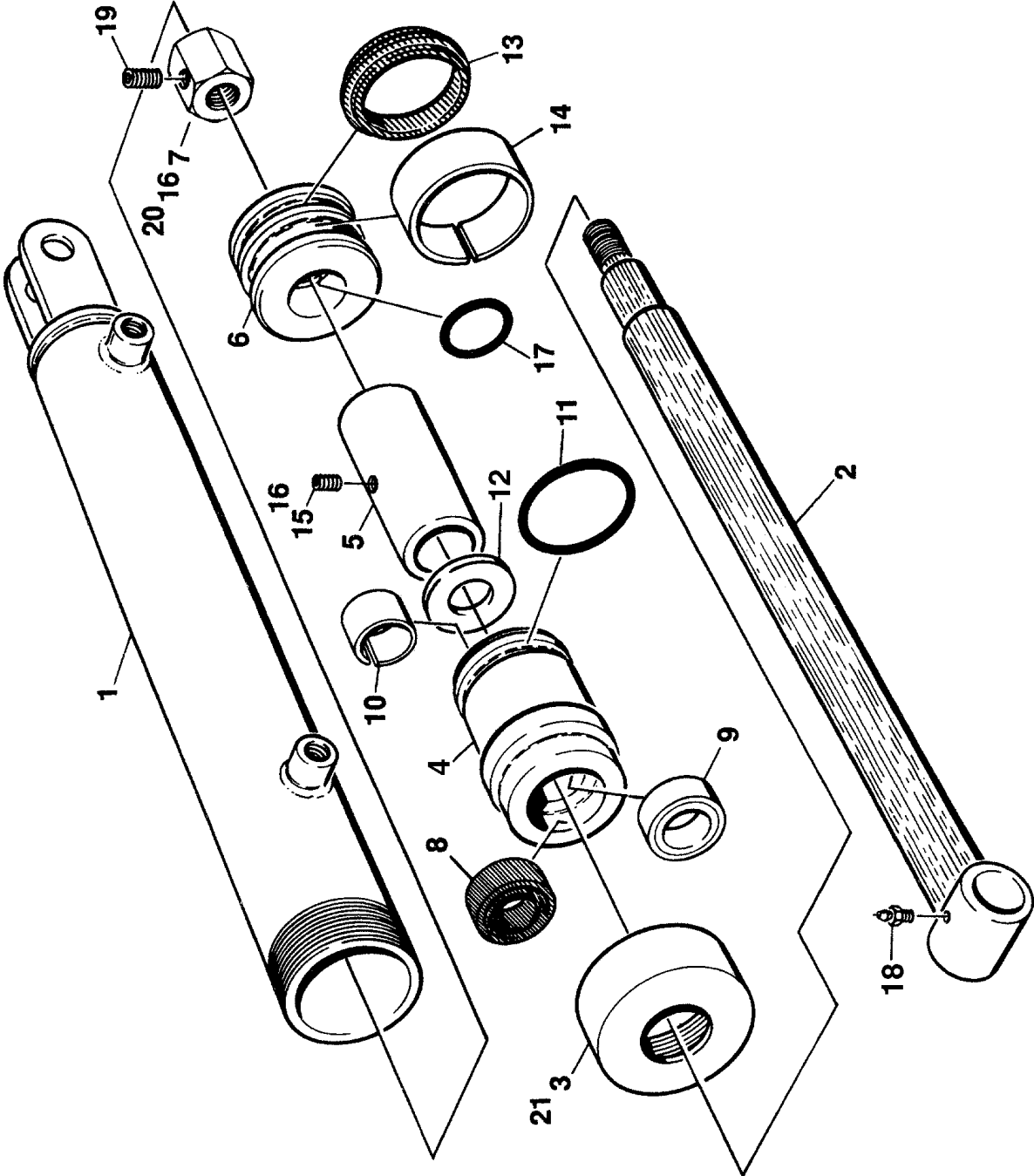

# SECTION 5 CYLINDERS

**FIGURE 5-10. STEER CYLINDER ASSEMBLIES**

FIG & ITEM #	PART NUMBER	DESCRIPTION	QTY.	REV.
		<b>STEER CYLINDER ASSEMBLIES</b>	Ref.	
		Cylinder Usage Chart:		
	1681562	2WD Front (Prior to May 1992)		
	1681562	2WD Front without Tow Package (May 1992 to Present)		
	1682780	2WD Front with Tow Package (May 1992 to Present)		
	1681555	4WD Front (Prior to February 1990)		
	1682203	4WD Front (February 1990 to May 1992)		
	1681555	4WD Front (May 1992 to Present)		
	1681555	4WS Option Rear		
		<b>STEER CYLINDER ASSEMBLY</b>	Ref.	
	1681562	<b>STEER CYLINDER ASSEMBLY</b>	Ref.	H
	1682780	<b>STEER CYLINDER ASSEMBLY</b>	Ref.	-
	1681555	<b>STEER CYLINDER ASSEMBLY</b>	Ref.	D
	1682203	<b>STEER CYLINDER ASSEMBLY</b>	Ref.	B
1		Barrel Assembly Options:	1	
	1681433	1681562 Cylinder Assembly		
	1682781	1682780 Cylinder Assembly		
	1681413	1681555 & 1682203 Cylinder Assembly		
2		Rod Assembly Options:	1	
	1681435	1681562 Cylinder Assembly		
	1682783	1682780 Cylinder Assembly		
	1681411	1681555 Cylinder Assembly		
	1682202	1682203 Cylinder Assembly		
3	1120108	Retainer	1	
4		Head Options:	1	
	1681322	1681562 & 1682780 Cylinder Assembly		
	1681344	1681555 & 1682203 Cylinder Assembly		
5		Spacer Options:	1	
	4562687	1681562 Cylinder Assembly		
	1440142	1682780 Cylinder Assembly		
	4562851	1681555 Cylinder Assembly		
	4564637	1682203 Cylinder Assembly		
6	3480134	Piston	1	
7		Nut Option:	1	
	3300187	Nut (Prior to January 1991)		
	3300273	Nut, Hex (January 1991 to Present)		
8	Kit	Seal, Wiper	1	
9	Kit	Seal, Rod	1	
10	Kit	Ring, Wear	1	
11	Kit	O-Ring		
12		Collar	1	
	Not Required	1681562, 1681555 & 1682203 Cylinder Assembly		
	4740377	1682780 Cylinder Assembly		
13	Kit	Seal, Piston	1	
14	Kit	Ring, Wear	1	

SECTION 5 CYLINDERS

# SECTION 5 CYLINDERS

**FIGURE 5-10. STEER CYLINDER ASSEMBLIES (CONTINUED)**

FIG & ITEM #	PART NUMBER	DESCRIPTION	QTY.	REV.
15	3900141	Setscrew 1/4"-20NC x 3/8"	A/R	
16	0100011	Loctite #242	A/R	
17	Kit	O-Ring	1	
18		Fitting Options:	1	
	2160001	1681562 Cylinder Assembly		
	2160002	1682780 & 1681555 Cylinder Assembly		
	2160006	1682203 Cylinder Assembly		
19		Setscrew Options:	A/R	
	3900141	Setscrew 1/4"-20NC x 3/8" (Prior to January 1991)	2	
	3900170	Setscrew 3/8"-16NC x 3/8" (January 1991 to Present)	1	
20	0100038	Primer, Locking	A/R	
21	0100035	Loctite #222	A/R	
		-----		
		Seal Kit - 1681562 Cylinder (Includes Items 8-14 and 17)	1	
	2901148	1681562 & 1682780 Cylinder Assemblies		
	2901123	1681555 & 1682203 Cylinder Assemblies		

**SECTION 5 CYLINDERS**

# SECTION 5 CYLINDERS

FIGURE 5-10. STEER CYLINDER ASSEMBLIES (CONTINUED)

FIG & ITEM #	PART NUMBER	DESCRIPTION	QTY.	REV.

**S  
E  
C  
T  
I  
O  
N  
  
5  
  
C  
Y  
L  
I  
N  
D  
E  
R  
S**

# SECTION 5 CYLINDERS

FIGURE 5-11. TELESCOPE CYLINDER ASSEMBLY (MODEL 60H AND 60H+6)

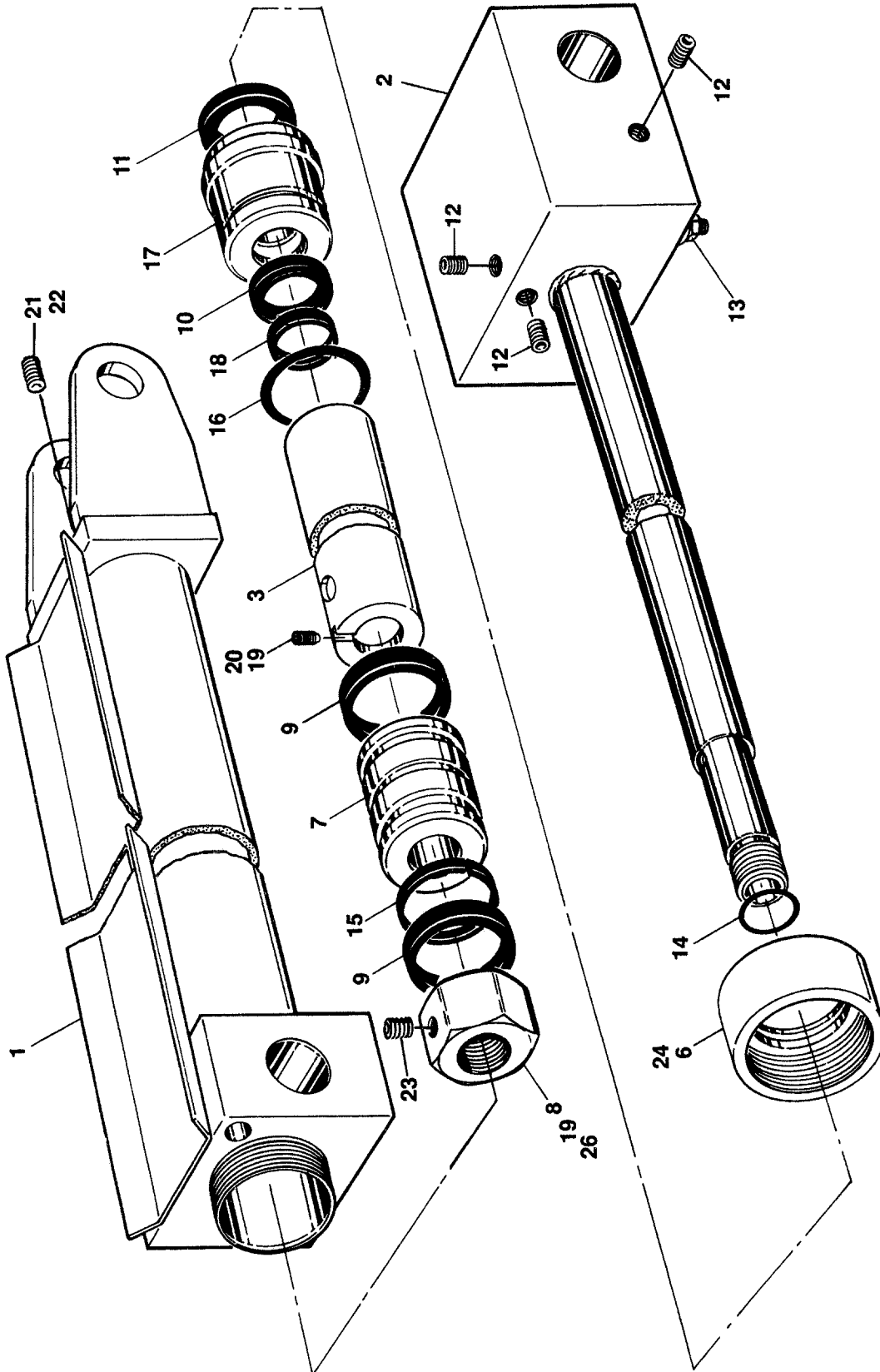

SECTION 5 CYLINDERS

# SECTION 5 CYLINDERS

**FIGURE 5-11. TELESCOPE CYLINDER ASSEMBLY (MODEL 60H AND 60H+6)**

FIG & ITEM #	PART NUMBER	DESCRIPTION	QTY.	REV.
	1681516	<b>TELESCOPE CYLINDER ASSEMBLY (MODEL 60H AND 60H+6)</b>	Ref.	G
1	1681349	Barrel Assembly	1	
2	1681350	Rod Assembly	1	
3	4562573	Spacer	1	
4	Not Used			
5	Not Used			
6	1120108	Retainer	1	
7	3480054	Piston	1	
8		Nut Options:	1	
	3300086	Nut (Prior to January 1991)		
	3300293	Nut, Hex (January 1991 to Present)		
9	Kit	Ring, Wear	2	
10	Kit	Seal, Rod	1	
11	Kit	Seal, Wiper	1	
12	2200102	Plug, Pipe 1/4"	4	
13	4640212	Valve, Cartridge - Holding	1	
	2900793	Seal Kit - 4640212 Valve	1	
14	Kit	T-Seal	1	
15	Kit	T-Seal	1	
16	Kit	O-Ring	1	
17	1681307	Head	1	
18	Kit	Ring, Wear	1	
19	0100011	Loctite #242	A/R	
20	3951405	Setscrew 1/4"-20NC x 5/8"	1	
21	4420001	Tape, Sealant	A/R	
22	2200221	Plug, Pipe 1/8"	1	
23	3900171	Setscrew	1	
24	0100035	Compound, Locking	A/R	
25	Not Used			
26	0100038	Primer, Locking	A/R	
		-----		
	2900350	Seal Kit - 1681516 Cylinder (Includes Items 9,10,11,14,15,16 and 18)	1	

**SECTION 5 CYLINDERS**

# SECTION 5 CYLINDERS

FIGURE 5-12. TELESCOPE CYLINDER ASSEMBLIES (MODEL 70H)

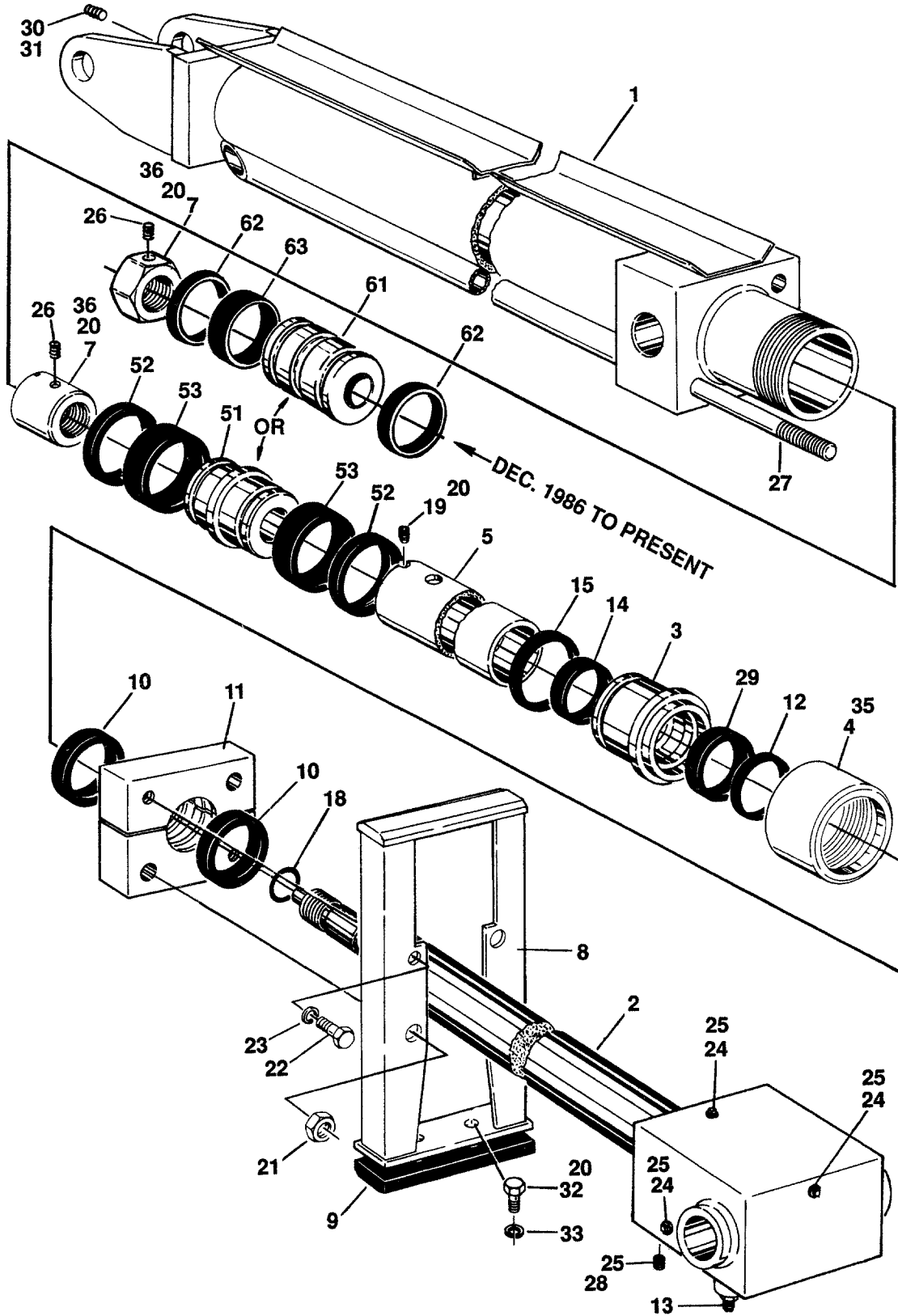

SECTION 5 CYLINDERS



# SECTION 5 CYLINDERS

**FIGURE 5-12. TELESCOPE CYLINDER ASSEMBLIES (MODEL 70H)**

FIG & ITEM #	PART NUMBER	DESCRIPTION	QTY.	REV.
		<b>TELESCOPE CYLINDER ASSEMBLIES (MODEL 70H)</b>	Ref.	
		<b>TELESCOPE CYLINDER ASSEMBLY (STANDARD PARTS)</b>	Ref.	
1	16814654	Barrel Assembly	1	
2	1681465	Rod Assembly	1	
3	1681307	Head	1	
4	1120108	Retainer	1	
5	4562961	Spacer	1	
6	Not Used			
7		Nut Options:	1	
	3300086	Nut (Prior to January 1991)		
	3300293	Nut, hex (January 1991 to Present)		
8	4841568	Support, Rod	1	
9	3340383	Pad, Wear	1	
10	Kit	Seal, Rod	2	
11	0560665	Block	1	
12	Kit	Seal, Wiper	1	
13	4640212	Valve, Cartridge - Holding	1	
14	Kit	Ring, Wear	1	
15	Kit	T-Seal	1	
16	Not Used			
17	Not Used			
18	Kit	T-Seal	1	
19	3951405	Setscrew 1/4"-20NC x 5/8"	1	
20	0100011	Loctite #242	A/R	
21	3312202	Nut, Jam 3/4"-10NC	2	
22	0641812	Bolt 1/2"-13NC x 1 1/2"	2	
23	4761800	Lockwasher 1/2"	2	
24	2200102	Plug, Pipe 1/4"	5	
25	0100020	Sealant, Pipe	A/R	
26		Setscrew Options:	A/R	
	3900141	Setscrew 1/4"-20NC x 3/8" (Prior to January 1991)	2	
	3900171	Setscrew 1/2"-13NC x 1/2" (January 1991 to Present)	1	
27	3840810	Rod, Guide	2	
28	2200213	Plug 3/8"	2	
29	Kit	Z-Seal	1	
30	2200221	Plug, Pipe 1/8"	1	
31	4420001	Tape, Sealant	A/R	
32	0641606	Bolt 3/8"-16NC x 3/4"	2	
33	4761600	Lockwasher 3/8"	2	
34	Not Used			
35	0100035	Loctite #222	A/R	
36	0100038	Primer, Locking	A/R	

# SECTION 5 CYLINDERS

**FIGURE 5-12. TELESCOPE CYLINDER ASSEMBLIES (MODEL 70H) (CONTINUED)**

FIG & ITEM #	PART NUMBER	DESCRIPTION	QTY.	REV.
	1681574	<b>TELESCOPE CYLINDER ASSEMBLY (PRIOR TO DECEMBER 1986) (VARIABLE PARTS)</b>	Ref.	E
51	3480092	Piston	1	
52	Kit	Ring, Lock	2	
53	Kit	Seal	2	
		-----		
	2900368	Seal Kit - 1681574 Cylinder (Includes Items 10, 14, 15, 18, 29, 52 and 53)		
	1681813	<b>TELESCOPE CYLINDER ASSEMBLY (DECEMBER 1986 TO PRESENT) (VARIABLE PARTS)</b>	Ref.	E
61	3480054	Piston	1	
62	Kit	Ring, Wear	2	
63	Kit	Seal	1	
		-----		
	2901139	Seal Kit - 1681813 Cylinder (Includes Items 10, 14, 15, 18, 29, 62 and 63)	1	

**SECTION 5 CYLINDERS**

# SECTION 5 CYLINDERS

FIGURE 5-12. TELESCOPE CYLINDER ASSEMBLIES (MODEL 70H) (CONTINUED)

FIG & ITEM #	PART NUMBER	DESCRIPTION	QTY.	REV.

**S  
E  
C  
T  
I  
O  
N  
  
5  
  
C  
Y  
L  
I  
N  
D  
E  
R  
S**

# SECTION 5 CYLINDERS

FIGURE 5-13. CYLINDER BELLOWS INSTALLATION

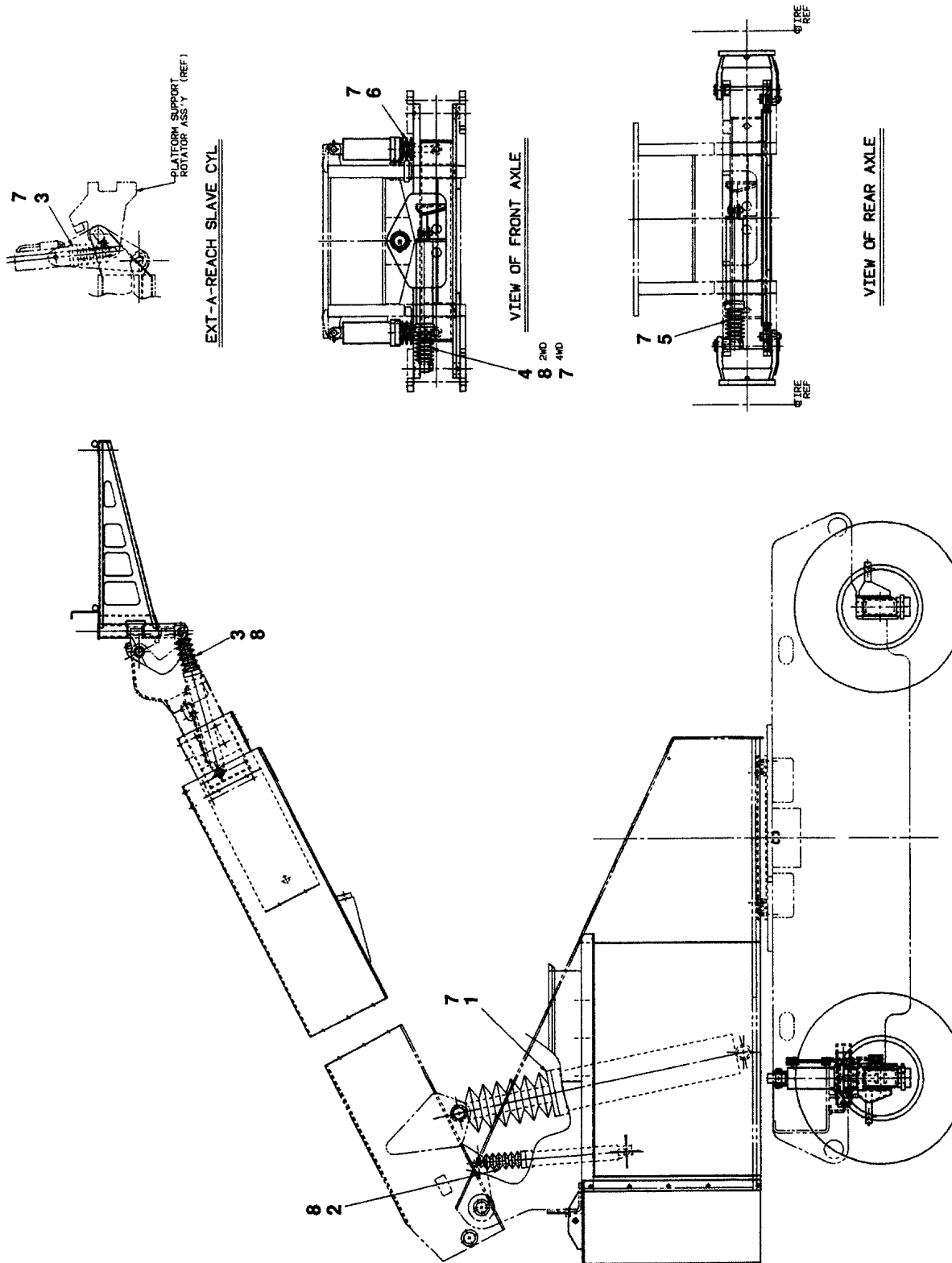

# SECTION 5 CYLINDERS

**FIGURE 5-13. CYLINDER BELLOWS INSTALLATION**

FIG & ITEM #	PART NUMBER	DESCRIPTION	QTY.	REV.
		<b>CYLINDER BELLOWS INSTALLATION</b>	Ref.	
	1280547	<b>CYLINDER BELLOWS INSTALLATION (PRIOR TO MAY 1992)</b>	Ref.	D
	1281861	<b>CYLINDER BELLOWS INSTALLATION (MAY 1992 TO PRESENT)</b>	Ref.	-
1	0460070	Bellows with Zipper (Lift Cylinder)	1	
2	0460071	Bellows with Zipper (Master Cylinder)	1	
3		Bellows with Zipper Options (Slave Cylinder):	1	
	0460101	60H and 70H		
	0460081	60H+6 Extend-A-Reach		
4		Bellows with Zipper Options (Front Steer Cylinder):	1	
	0460073	2WD		
	0460075	4WD		
5	0460075	Bellows with Zipper (Rear Steer Cylinder)	1	
6		Bellows with Zipper Options (Axle Lockout Cylinders):	2	
	0460074	Machines Built Prior to May 1992		
	0460104	Machines Built May 1992 to Present		
7	1320122	Clamp, Worm Gear 5 1/8"-6" Dia.	A/R	
8	1320037	Clamp, Worm Gear 3"-4 1/8" Dia.	A/R	

# SECTION 5 CYLINDERS

FIGURE 5-13. CYLINDER BELLOWS INSTALLATION (CONTINUED)

FIG & ITEM #	PART NUMBER	DESCRIPTION	QTY.	REV.

**S  
E  
C  
T  
I  
O  
N  
  
5  
  
C  
Y  
L  
I  
N  
D  
E  
R  
S**

# SECTION 6 HYDRAULICS

<b>TABLE OF CONTENTS</b>		
<b>FIGURE</b>	<b>DESCRIPTION</b>	<b>PAGE</b>
6-1	HYDRAULIC DIAGRAM - AXLE LOCKOUT .....	6-2
6-2	HYDRAULIC DIAGRAM - DRIVE (2WD) .....	6-4
6-3	HYDRAULIC DIAGRAM - DRIVE (4WD) .....	6-6
6-4	HYDRAULIC DIAGRAM - LEVEL (60H & 70H) (Standard Parts) .....	6-10
6-5	HYDRAULIC DIAGRAM - LEVEL (60H+6 With Rotating Platform) .....	6-12
6-6	HYDRAULIC DIAGRAM - LIFT .....	6-14
6-7	HYDRAULIC DIAGRAM - MANUAL DESCENT .....	6-16
6-8	HYDRAULIC DIAGRAM - PUMP (Standard Controls) .....	6-18
6-9	HYDRAULIC DIAGRAM - PUMP (Hydraulic Controls) .....	6-22
6-10	HYDRAULIC DIAGRAM - ROTATE (Standard Controls) .....	6-26
6-11	HYDRAULIC DIAGRAM - SEQUENCE LINE .....	6-28
6-12	HYDRAULIC DIAGRAM - STEER .....	6-30
6-13	HYDRAULIC DIAGRAM - SWING .....	6-32
6-14	HYDRAULIC DIAGRAM - TELESCOPE .....	6-34
6-15	HYDRAULIC DIAGRAM LIST .....	6-36

# SECTION 6 HYDRAULICS

FIGURE 6-1. HYDRAULIC DIAGRAM - AXLE LOCKOUT

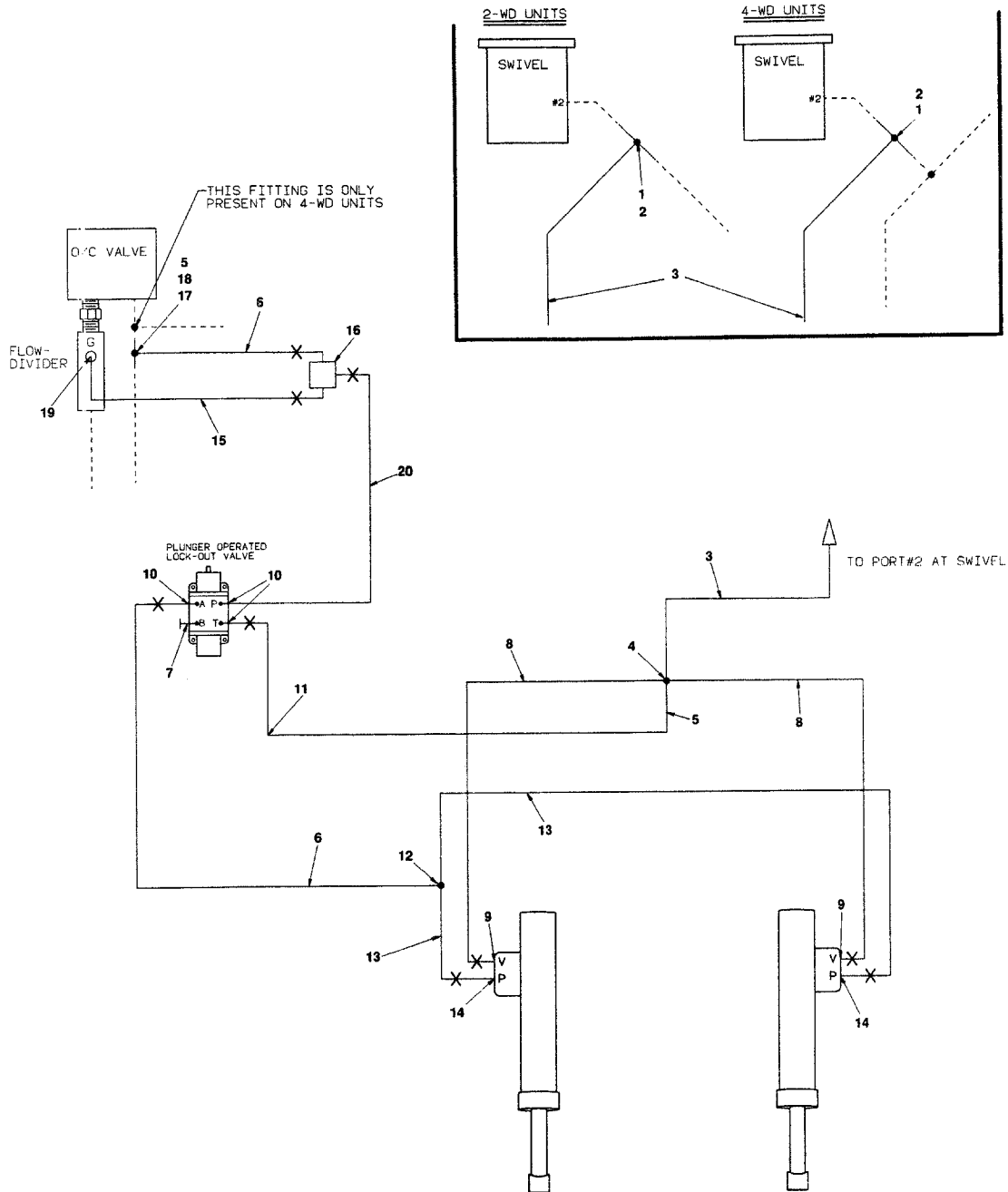



# SECTION 6 HYDRAULICS

**FIGURE 6-1. HYDRAULIC DIAGRAM - AXLE LOCKOUT**

FIG & ITEM #	PART NUMBER	DESCRIPTION	QTY.	REV.
	2791899	<b>HYDRAULIC DIAGRAM - AXLE LOCKOUT</b>	Ref.	-
1	2220385	Fitting, Tee	1	
2	2220619	Fitting, Reducer	1	
3	2750786	Hose	1	
4	2220827	Fitting, Cross	1	
5	2220609	Fitting, Reducer	2	
6	2750901	Hose	2	
7	2220235	Fitting, Plug	1	
8	2751003	Hose	2	
9	2220371	Fitting, Straight	2	
10	2220415	Fitting, Straight	3	
11	2751018	Hose	1	
12	2220504	Fitting, Tee	1	
13	1751010	Hose	2	
14	2220582	Fitting, Straight	2	
15	2750902	Hose	1	
16	4640574	Valve, Shuttle	1	
17	2220700	Fitting, Tee	1	
18	2220621	Fitting, Reducer	1	
19	2220466	Fitting, 90°	1	
20	2751396	Hose	1	

# SECTION 6 HYDRAULICS

FIGURE 6-2. HYDRAULIC DIAGRAM - DRIVE (2WD)

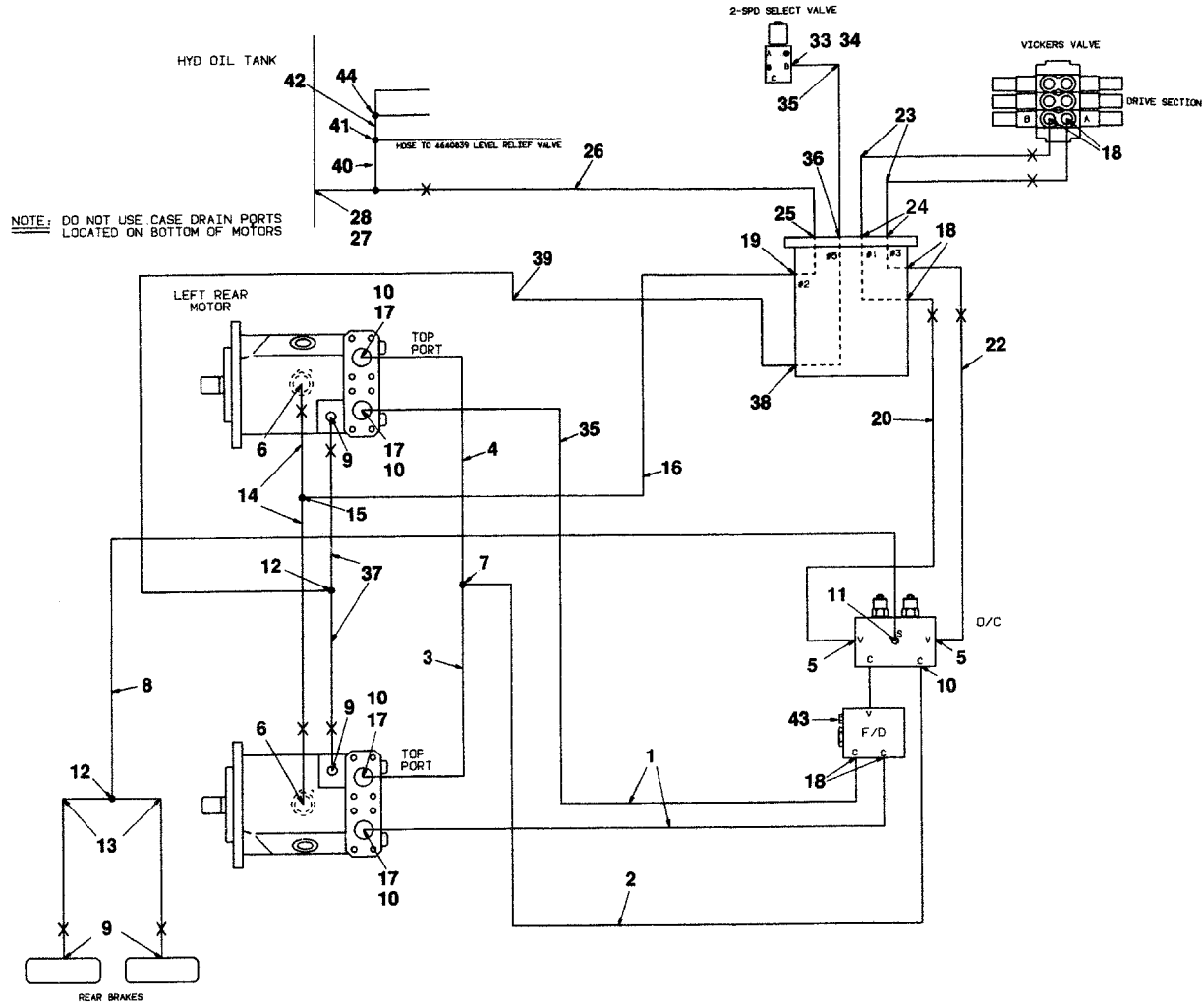

# SECTION 6 HYDRAULICS

**FIGURE 6-2. HYDRAULIC DIAGRAM - DRIVE (2WD)**

FIG & ITEM #	PART NUMBER	DESCRIPTION	QTY.	REV.
	2791894	<b>HYDRAULIC DIAGRAM - DRIVE (2WD)</b>	Ref.	D
1	2751364	Hose	2	
2	2750874	Hose	1	
3	2751359	Hose	1	
4	2751327	Hose	1	
5	2220465	Fitting, 90°	2	
6	2220374	Fitting, Straight	2	
7	2220481	Fitting, Tee	1	
8	2751026	Hose	1	
9	2220415	Fitting, Straight	4	
10	2220435	Fitting, Straight	5	
11	2220466	Fitting, 90°	1	
12	2220504	Fitting, Tee	2	
13	2750899	Hose	2	
14	2750972	Hose	2	
15	2220362	Fitting, Tee	1	
16	2750776	Hose	1	
17	2220858	Flange, Straight	4	
18	2220451	Fitting	4	
19	2220355	Fitting, 45°	1	
20	2750685	Hose	1	
21	2220347	Fitting, Straight	2	
22	2750872	Hose	1	
23	2751321	Hose	2	
24	2220356	Fitting, 45°	2	
25	5550345	Fitting, Straight	1	
26	2750971	Hose	1	
27		Fitting, Tee Options:	1	
	2220867	Prior to May 1995		
	2220362	May 1995 to Present		
28	2220868	Fitting	1	
29 to 32	Not Used			
33	2220585	Fitting, 90°	1	
34	2220822	Fitting, Restrictor	1	
35	2751026	Hose	1	
36	2220414	Fitting, Straight	1	
37	2751010	Hose	2	
38	2220416	Fitting, 90°	1	
39	2751011	Hose	1	
40		Fitting Options:	1	
	2220607	Prior to May 1995		
	2220619	May 1995 to Present		
41	2220635	Fitting	1	
42	2220609	Fitting	1	
43	2220235	Fitting	1	
44	2220605	Fitting	1	

# SECTION 6 HYDRAULICS

FIGURE 6-3. HYDRAULIC DIAGRAM - DRIVE (4WD)

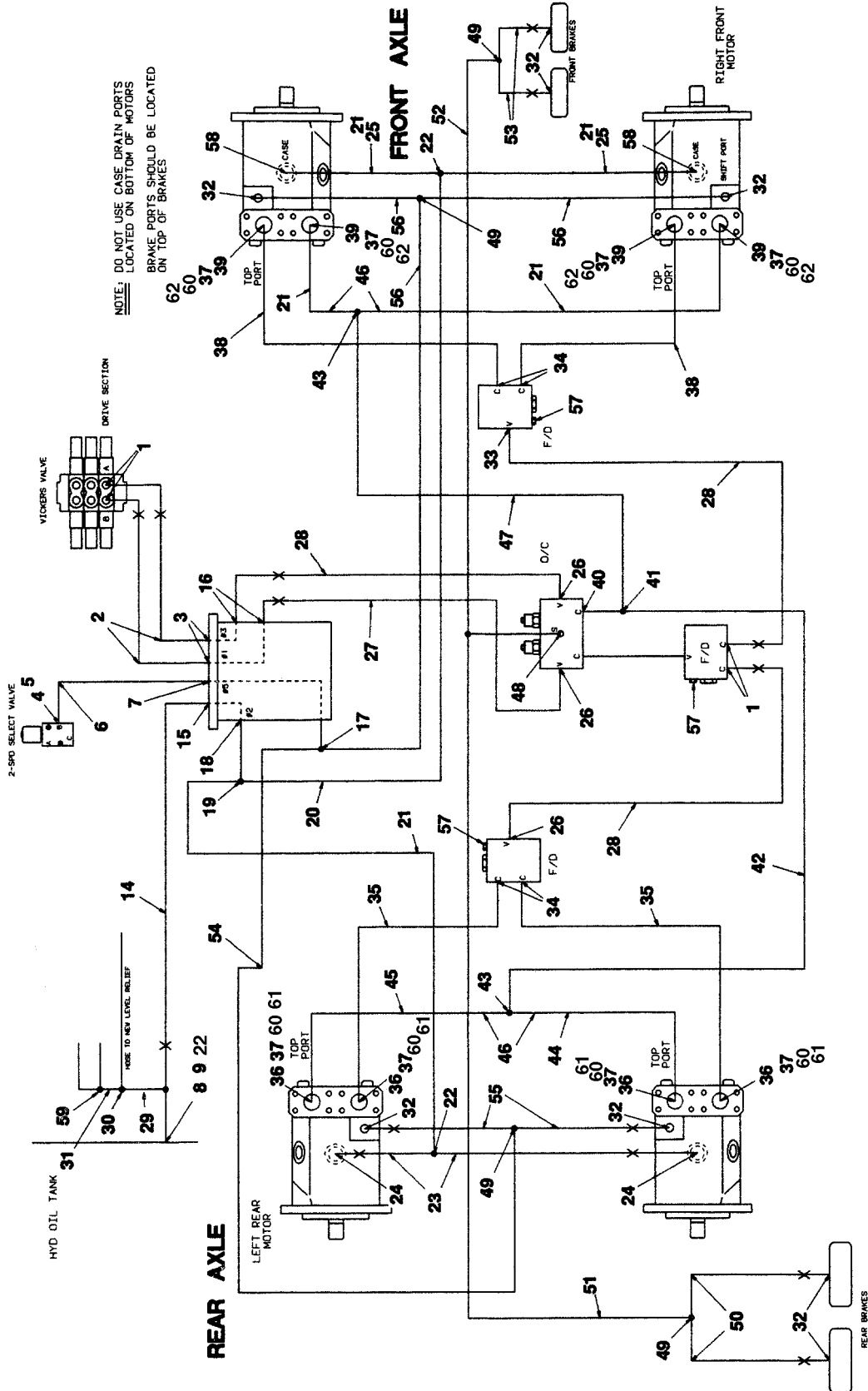

# SECTION 6 HYDRAULICS

**FIGURE 6-3. HYDRAULIC DIAGRAM - DRIVE (4WD)**

FIG & ITEM #	PART NUMBER	DESCRIPTION	QTY.	REV.
	2791895	<b>HYDRAULIC DIAGRAM - DRIVE (4WD)</b>	Ref.	7
1	2220451	Fitting, Straight	4	
2	2751321	Hose	2	
3	2220356	Fitting, 45°	2	
4	2220585	Fitting, 90°	1	
5	2220822	Fitting, Restrictor	1	
6	2751026	Hose	1	
7	2220414	Fitting, Straight	1	
8	2220868	Fitting, Straight	1	
9	2220867	Fitting, Tee (Prior to S/N 36792)	1	
10	Not Used			
11	Not Used			
12	Not Used			
13	Not Used			
14	2750971	Hose	1	
15	2220345	Fitting, Straight	1	
16	2220347	Fitting, Straight	2	
17	2220584	Fitting, Tee	1	
18	2220355	Fitting, 45°	1	
19	2220383	Fitting, Tee	1	
20	2750773	Hose	1	
21	2750776	Hose	A/R	
22	2220362	Fitting, Tee	A/R	
23	2750972	Hose	2	
24	2220374	Fitting, Straight	2	
25	2751469	Hose (Prior to July 1995)	2	
26	2220465	Fitting, 90°	3	
27	2750685	Hose	1	
28	2750872	Hose	3	
29	2220607	Fitting	1	
30	2220635	Fitting	1	
31	2220609	Fitting	1	
32	2220415	Fitting, Straight	8	
33	2220435	Fitting, Straight	1	
34	2220375	Fitting, Straight	4	
35	2751489	Hose	2	
36	2220858	Flange Kit - 90° (Prior to July 1995)	4	
37	2220800	Fitting, Straight (Prior to August 1995)	8	
38	2751465	Hose	2	
39	2220857	Flange Kit - Straight (Prior to July 1995)	4	
40	2220550	Fitting, Reducer	1	
41	2220738	Fitting, Tee	1	
42	2750874	Hose	1	
43	2220481	Fitting, Tee	2	
44	2750976	Hose	1	
45	2750929	Hose	1	
46	2220622	Fitting, Reducer	4	
47	2751333	Hose	1	

## SECTION 6 HYDRAULICS

**FIGURE 6-3. HYDRAULIC DIAGRAM - DRIVE (4WD)**

FIG & ITEM #	PART NUMBER	DESCRIPTION	QTY.	REV.
48	2220711	Fitting, Tee	1	
49	2220504	Fitting, Tee	4	
50	2750899	Hose	2	
51	2751021	Hose	1	
52	2751906	Hose	1	
53	2750891	Hose	2	
54	2751011	Hose	1	
55	2751010	Hose	2	
56	2751398	Hose	3	
57	2220235	Fitting, Plug	3	
58		Fitting Options:	2	
	2220671	Fitting, 90° (Prior to July 1995)		
	2220499	Fitting, 45° (July 1995 to Present)		
59	2220605	Fitting	1	
60	2220833	Fitting, Reducer (August 1995 to Present)	8	
61	2220596	Fitting, 90° (August 1995 to Present)	4	
62	2220500	Fitting, 45° (August 1995 to Present)	4	

# SECTION 6 HYDRAULICS

**FIGURE 6-3. HYDRAULIC DIAGRAM - DRIVE (4WD)**

FIG & ITEM #	PART NUMBER	DESCRIPTION	QTY.	REV.

SECTION 6 HYDRAULICS

FIGURE 6-4. HYDRAULIC DIAGRAM - LEVEL (60H AND 70H) (STANDARD PARTS)

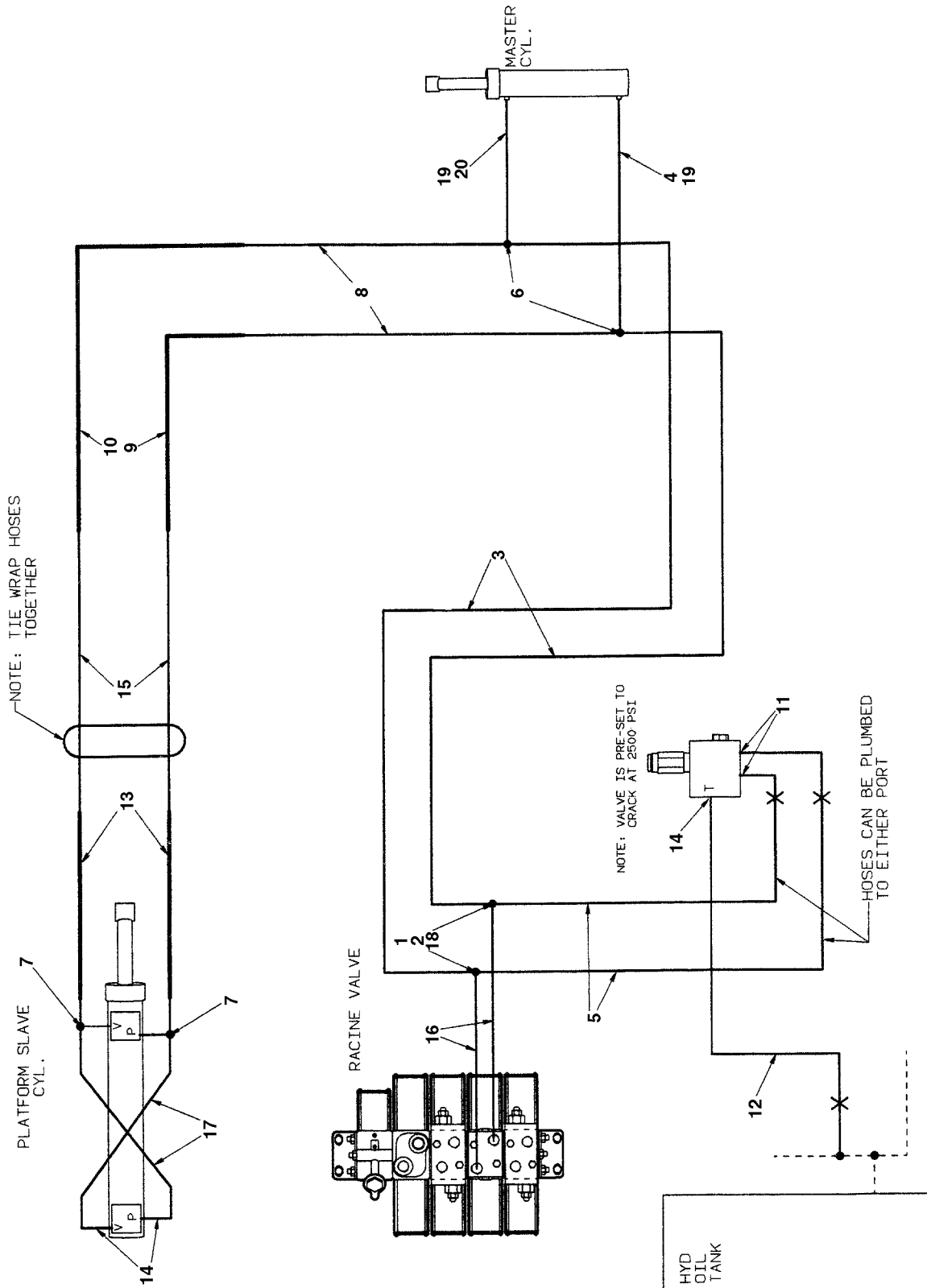



# SECTION 6 HYDRAULICS

**FIGURE 6-4. HYDRAULIC DIAGRAM - LEVEL (60H AND 70H) (STANDARD PARTS)**

FIG & ITEM #	PART NUMBER	DESCRIPTION	QTY.	REV.
	2792054	HYDRAULIC DIAGRAM - LEVEL (60H)	Ref.	-
	2792066	HYDRAULIC DIAGRAM - LEVEL (70H)	Ref.	A
1	2180379	Fitting, Modified Tee	2	
2	2180615	Fitting, Orifice (.47)	2	
3	2750998	Hose	2	
4	2750779	Hose	1	
5	2750990	Hose	2	
6	2220490	Fitting, Tee	2	
7	2220899	Fitting, Tee	2	
8		Hose Options:	2	
	2751830	Hose - Model 60H		
	2751151	Hose - Model 70H		
9		Tube Options:	1	
	4562916	Tube - Model 60H		
	4563122	Tube - Model 70H		
10		Tube Options:	1	
	4562532	Tube - Model 60H		
	4563122	Tube - Model 70H		
11	2220371	Fitting, Straight	2	
12	2750910	Hose	1	
13	4565873	Tube	2	
14	2220473	Fitting, 90°	3	
15		Hose Options:	2	
	2751829	Hose - Model 60H		
	2751115	Hose - Model 70H		
16	2220591	Fitting, 90°	2	
17	2750918	Hose	2	
18	0100011	Loctite (Not Shown)	A/R	
19		Fitting Options:	2	
	2220495	Fitting, 90° - Model 60H		
	2220343	Fitting, Straight - Model 70H		
20	2750785	Hose	1	

# SECTION 6 HYDRAULICS

FIGURE 6-5. HYDRAULIC DIAGRAM - LEVEL (60H+6 WITH ROTATING PLATFORM)

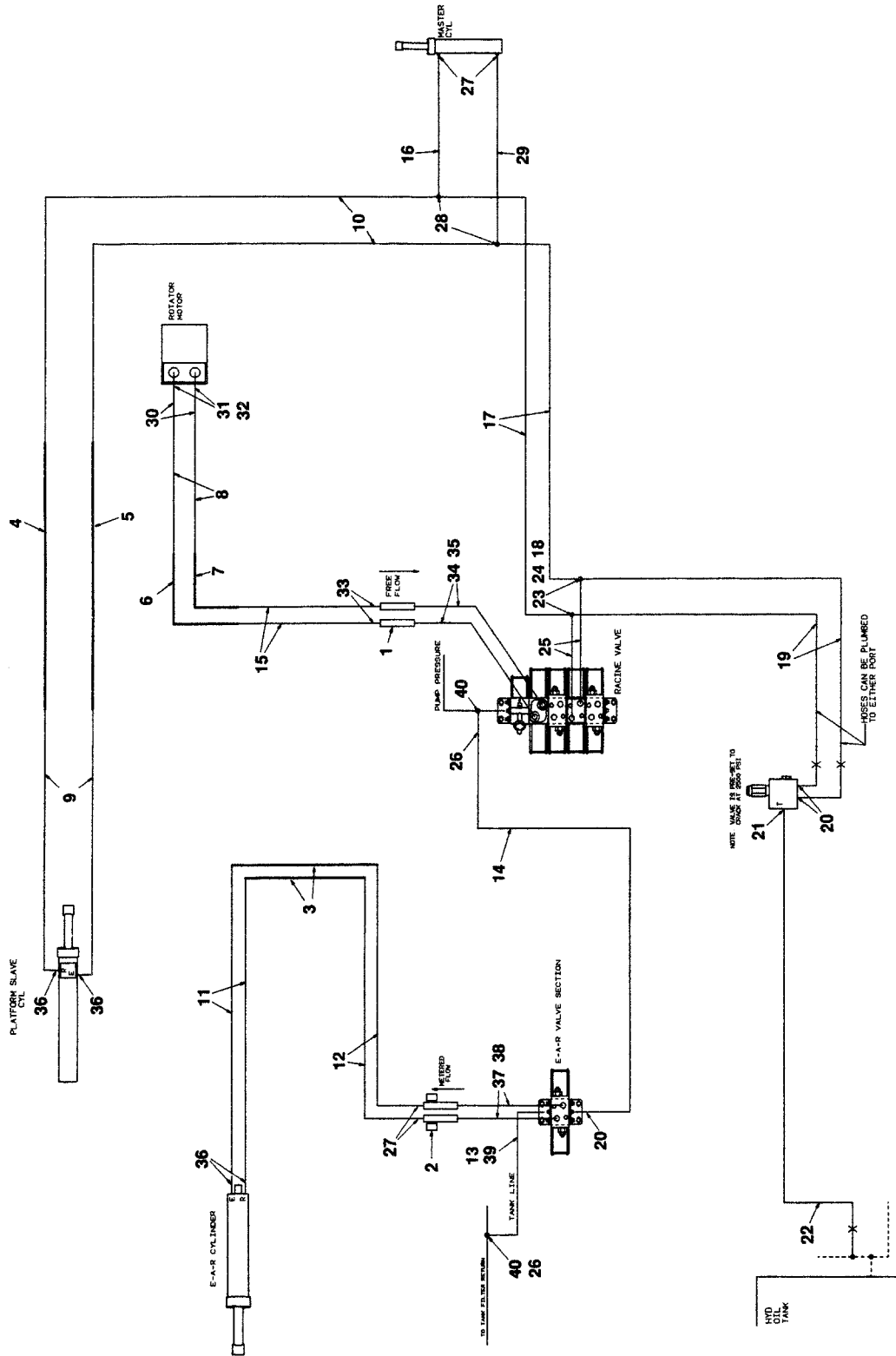

# SECTION 6 HYDRAULICS

**FIGURE 6-5. HYDRAULIC DIAGRAM - LEVEL (60H+6 WITH ROTATING PLATFORM)**

FIG & ITEM #	PART NUMBER	DESCRIPTION	QTY.	REV.
	2792052	<b>HYDRAULIC DIAGRAM - LEVEL (60H+6 WITH ROTATING PLATFORM)</b>	Ref.	A
1	4640383	Valve, Restrictor (.030)	2	
2	4640216	Valve, Flow Control	2	
3	4562719	Tube	2	
4	4562916	Tube	1	
5	4562532	Tube	1	
6	4562531	Tube	1	
7	4562914	Tube	1	
8	2751904	Hose	2	
9	2751862	Hose	2	
10	2751830	Hose	2	
11	2751856	Hose	2	
12	2751833	Hose	2	
13	2750997	Hose	1	
14	2750919	Hose	1	
15	2751444	Hose	2	
16	2750785	Hose	1	
17	2750998	Hose	2	
18	0100011	Loctite	A/R	
19	2750990	Hose	2	
20	2220371	Fitting, Straight	3	
21	2220473	Fitting, 90°	1	
22	2750910	Hose	1	
23	2180379	Fitting	2	
24	2180615	Fitting	2	
25	2220591	Fitting	2	
26	2220619	Fitting	2	
27	2220343	Fitting	4	
28	2220490	Fitting	2	
29	2750779	Hose	1	
30	2220507	Fitting	2	
31	2220609	Fitting	2	
32	2220497	Fitting	2	
33	2220414	Fitting	2	
34	2220446	Fitting	2	
35	2220438	Fitting	2	
36	2220399	Fitting	4	
37	2220113	Fitting	3	
38	2220280	Fitting	2	
39	2220372	Fitting	1	
40	2220385	Fitting	2	

# SECTION 6 HYDRAULICS

FIGURE 6-6. HYDRAULIC DIAGRAM - LIFT

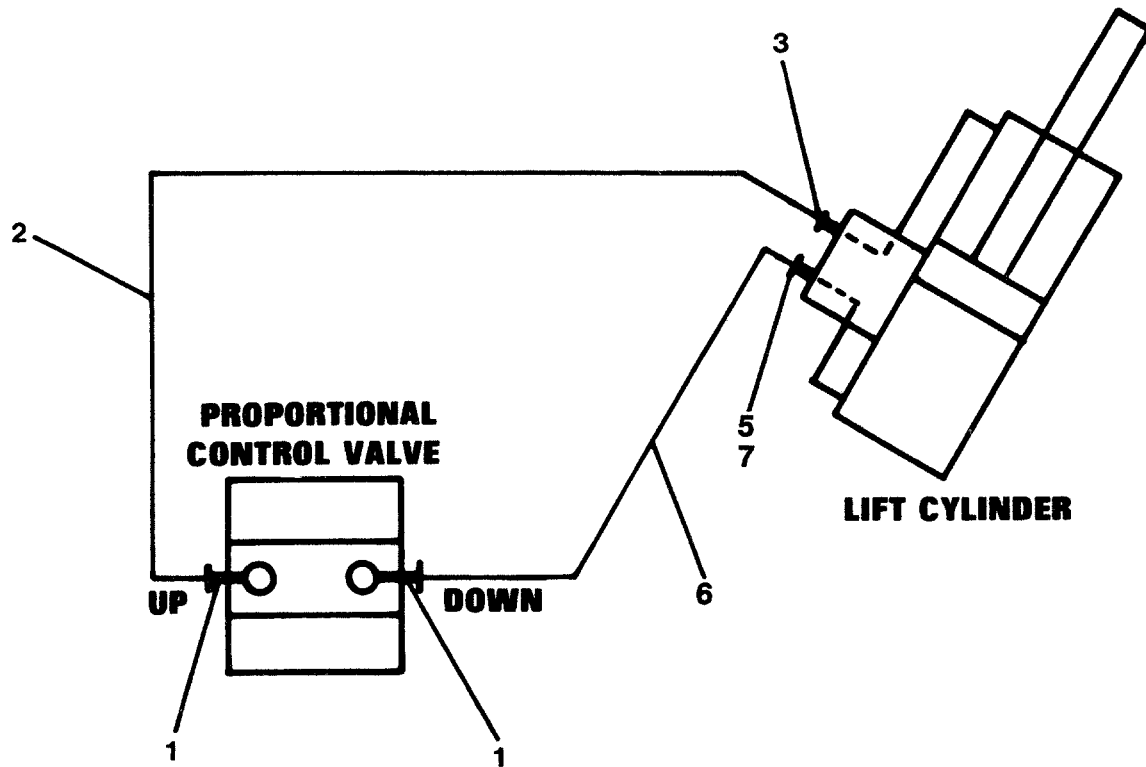

# SECTION 6 HYDRAULICS

**FIGURE 6-6. HYDRAULIC DIAGRAM - LIFT**

FIG & ITEM #	PART NUMBER	DESCRIPTION	QTY.	REV.
	2791252	<b>HYDRAULIC DIAGRAM - LIFT</b>	Ref.	D
1	2220577	Fitting, Straight	2	
2	2750994	Hose	1	
3	2220473	Fitting, 90°	1	
4	Not Used			
5	2180724	Fitting, Modified 90°	1	
6	2751110	Hose	1	
7	2180486	Orifice (.125)	1	

# SECTION 6 HYDRAULICS

FIGURE 6-7. HYDRAULIC DIAGRAM - MANUAL DESCENT

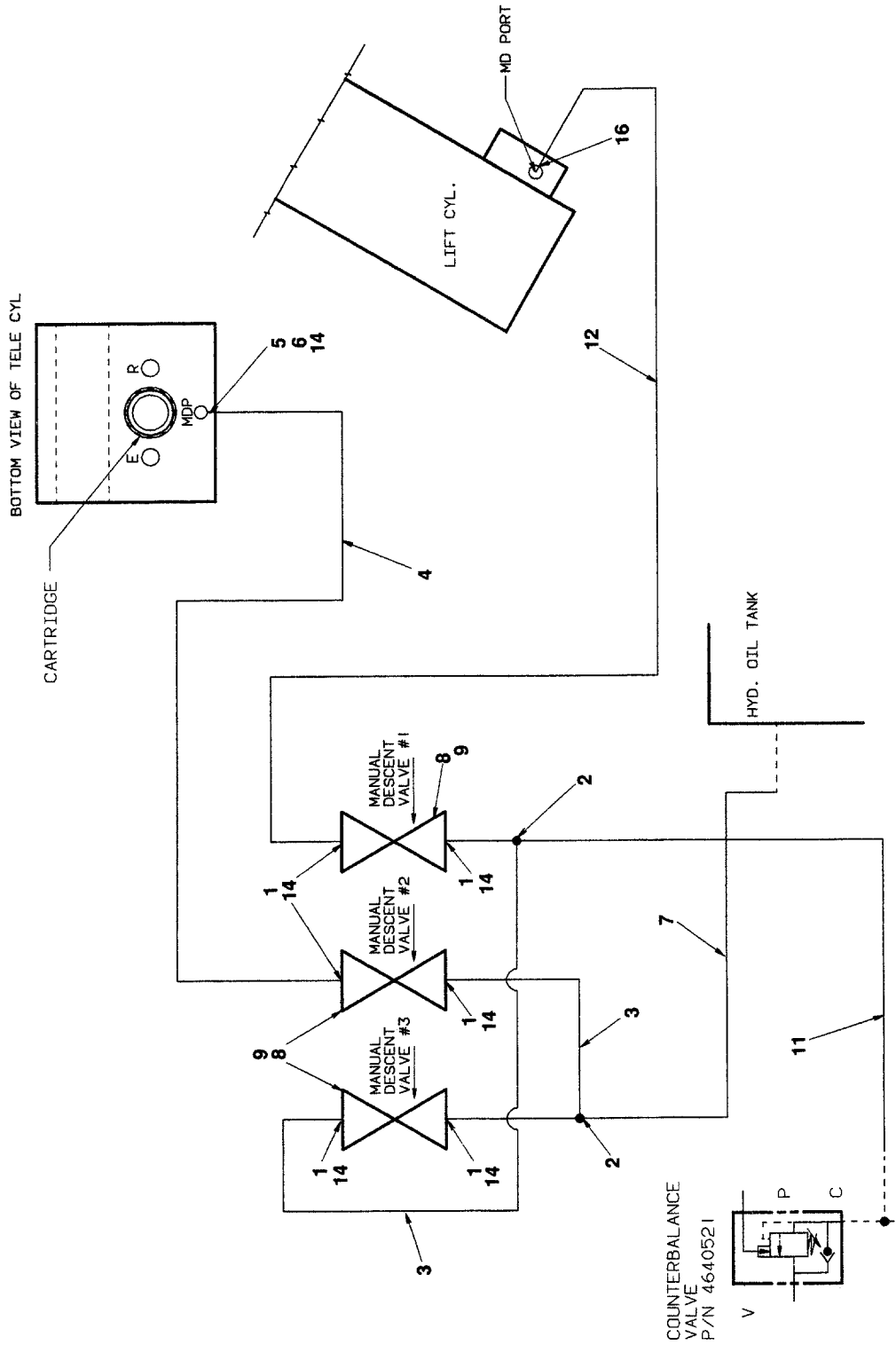

# SECTION 6 HYDRAULICS

**FIGURE 6-7. HYDRAULIC DIAGRAM - MANUAL DESCENT**

FIG & ITEM #	PART NUMBER	DESCRIPTION	QTY.	REV.
	2790946	<b>HYDRAULIC DIAGRAM - MANUAL DESCENT</b>	Ref.	G
1	2220416	Fitting, 90°	6	
2	2220605	Fitting, 90°	2	
3	2750900	Hose	2	
4	2750896	Hose	1	
5	2220414	Fitting, Straight	1	
6	2220462	Fitting, 90°	1	
7	2750895	Hose	2	
8	4640005	Valve, Needle	3	
9	2900062	Panel Kit	3	
10	Not Used			
11	2220609	Fitting, Reducer	1	
12	2750894	Hose	1	
13	Not Used			
14	0100020	Sealant, Thread (Not Shown)	A/R	
15	Not Used			
16	2220466	Fitting, 90°	1	

# SECTION 6 HYDRAULICS

FIGURE 6-8. HYDRAULIC DIAGRAM - PUMP (STANDARD CONTROLS)

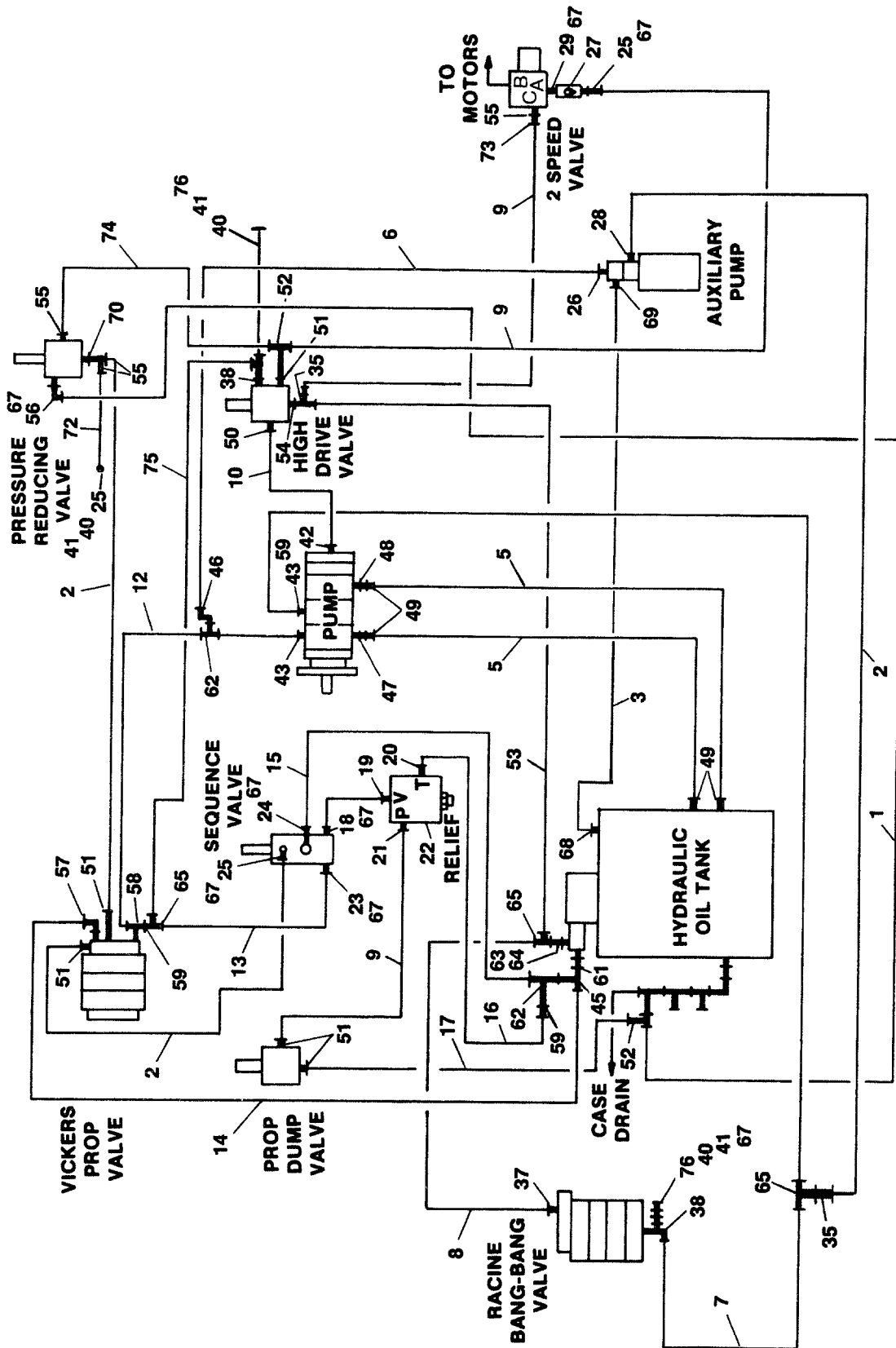



# SECTION 6 HYDRAULICS

**FIGURE 6-8. HYDRAULIC DIAGRAM - PUMP (STANDARD CONTROLS)**

FIG & ITEM #	PART NUMBER	DESCRIPTION	QTY.	REV.
	2791263	<b>HYDRAULIC DIAGRAM - PUMP (STANDARD CONTROLS)</b>	Ref.	I
1	2751015	Hose	1	
2	2750889	Hose	3	
3	2750127	Hose	1	
4	Not Used			
5	2720244	Hose (2 Sections - 31 1/2" Each Length)	A/R	
6	2751004	Hose	1	
7	2751484	Hose	1	
8	2751482	Hose	1	
9	2750902	Hose	3	
10	2751467	Hose	1	
11	Not Used			
12	2751337	Hose	1	
13	2751494	Hose	1	
14	2751359	Hose	1	
15	2750874	Hose	1	
16	2750970	Hose	1	
17	2751017	Hose	1	
18	2220847	Fitting	1	
19	2220898	Fitting, Swivel	1	
20	2220374	Fitting, Straight	1	
21	2220472	Fitting, 90°	1	
22	4640520	Valve, Relief	1	
23	2220346	Fitting, Straight	1	
24	2220347	Fitting, Straight	1	
25	2220414	Fitting, Straight	3	
26	2220371	Fitting, Straight	1	
27	4640197	Valve, Check	1	
28	2220415	Fitting, Straight	1	
29	2220673	Fitting, 90°	1	
30	Not Used			
31	Not Used			
32	Not Used			
33	Not Used			
34	Not Used			
35	2220618	Fitting, Reducer	2	
36	Not Used			
37	2220373	Fitting, Straight	1	
38	2180491	Fitting, Modified 90°	2	
39	Not Used			
40	2220428	Fitting, Quick Disconnect	3	
41	2220429	Cap, Dust	3	
42	2220375	Fitting, Straight	2	
43	4640575	Valve, Check	2	
44	Not Used			
45	2220681	Fitting, Tee	1	

## SECTION 6 HYDRAULICS

FIGURE 6-8. HYDRAULIC DIAGRAM - PUMP (STANDARD CONTROLS)

FIG & ITEM #	PART NUMBER	DESCRIPTION	QTY.	REV.
46	2220621	Fitting, Reducer	1	
47	2220809	Fitting, 45°	1	
48	2220808	Fitting, 45°	1	
49	1320031	Clamp	8	
50	2220596	Fitting, 90°	1	
51	2220582	Fitting, Straight	4	
52	2220605	Fitting, Tee	2	
53	2750977	Hose	1	
54	2220602	Fitting, Tee	1	
55	2220417	Fitting, Straight	4	
56	2220585	Fitting, 90°	1	
57	2220465	Fitting, 90°	1	
58	2220695	Fitting, Tee	1	
59	2220622	Fitting, Reducer	3	
60	Not Used			
61	2220696	Fitting, Reducer	1	
62	2220700	Fitting, Tee	2	
63	2220491	Fitting, Straight	1	
64	2220624	Fitting, Reducer	1	
65	2220385	Fitting, Tee	3	
66	Not Used			
67	0100020	Sealant, Thread	A/R	
68	2220070	Fitting	1	
69	2220114	Fitting, 90°	1	
70	2220444	Fitting, Tee	1	
71	Not Used			
72	2751397	Hose	1	
73	2220909	Fitting, Orifice	1	
74	2751018	Hose	1	
75	2751506	Hose	1	
76	2220820	Fitting, 90°	2	

# SECTION 6 HYDRAULICS

FIGURE 6-8. HYDRAULIC DIAGRAM - PUMP (STANDARD CONTROLS)

FIG & ITEM #	PART NUMBER	DESCRIPTION	QTY.	REV.

# SECTION 6 HYDRAULICS

FIGURE 6-9. HYDRAULIC DIAGRAM - PUMP (HYDRAULIC CONTROLS)

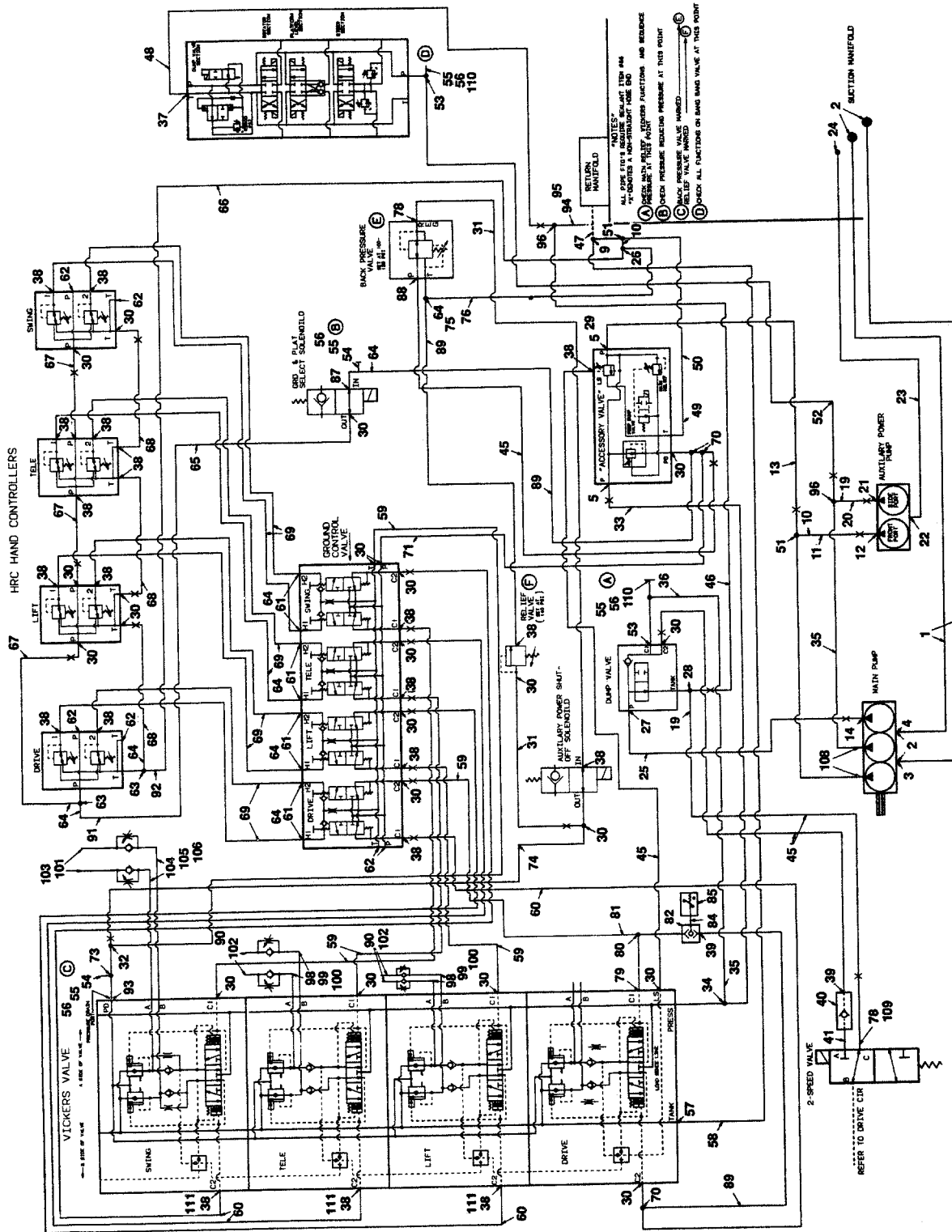

# SECTION 6 HYDRAULICS

**FIGURE 6-9. HYDRAULIC DIAGRAM - PUMP (HYDRAULIC CONTROLS)**

FIG & ITEM #	PART NUMBER	DESCRIPTION	QTY.	REV.
		<b>HYDRAULIC DIAGRAM - PUMP (HYDRAULIC CONTROLS)</b>	Ref.	
	1281012	<b>HYDRAULIC DIAGRAM - PUMP (STANDARD PARTS)</b>	Ref.	G
1	2720244	Hose, Suction (2 Sections - 30" each Length)	A/R	
2	1320032	Clamp	8	
3	2220809	Fitting, 45°	1	
4	2220808	Fitting, 45°	1	
5	2220451	Fitting, Straight	2	
6	Not Used			
7	Not Used			
8	Not Used			
9	2220681	Fitting, Tee	1	
10	2220621	Fitting, Reducer	2	
11	2751004	Hose	1	
12	2220603	Fitting, Straight	1	
13	2751337	Hose	1	
14	2220375	Fitting, Straight	1	
15	Not Used			
16	Not Used			
17	Not Used			
18	Not Used			
19	2220618	Fitting, Reducer	2	
20	2750889	Hose	1	
21	2220415	Fitting, Straight	1	
22	2220117	Fitting, 90°	1	
23	2750127	Hose	1	
24	2220070	Fitting, 90°	1	
25	2751467	Hose	1	
26	2220635	Fitting, Tee	1	
27	2220596	Fitting, 90°	1	
28	2220602	Fitting, Tee	1	
29	2220413	Fitting, 90°	1	
30	2220582	Fitting, Straight	22	
31	2750900	Hose	2	
32	2220684	Fitting, Tee	1	
33	2750872	Hose	1	
34	2220738	Fitting, Tee	1	
35	2220622	Fitting, Reducer	2	
36	2751506	Hose	1	
37	2220373	Fitting, Straight	1	
38	2220472	Fitting, 90°	22	
39	2220414	Fitting, Straight	2	
40	4640197	Valve, Check - 1/4"	1	
41	2220673	Fitting, 90°	1	
42	Not used			

## SECTION 6 HYDRAULICS

FIGURE 6-9. HYDRAULIC DIAGRAM - PUMP (HYDRAULIC CONTROLS)

FIG & ITEM #	PART NUMBER	DESCRIPTION	QTY.	REV.
43	Not Used			
44	Not Used			
45	2750902	Hose	4	
46	2750977	Hose	1	
47	2220696	Fitting, Reducer	1	
48	2751482	Hose	1	
49	2220498	Fitting, 45°	1	
50	2750874	Hose	1	
51	2220700	Fitting, Tee	2	
52	2751484	Hose	1	
53	2180491	Fitting, Modified 90°	2	
54	2220261	Fitting, Nipple	2	
55	2220428	Fitting, Quick Disconnect	4	
56	2220429	Cap, Dust	4	
57	2220465	Fitting, 90°	1	
58	2751359	Hose	1	
59	2751391	Hose	5	
60	2751396	Hose	4	
61	2220819	Fitting, 90°	8	
62	2220237	Fitting, Plug	6	
63	2220606	Fitting, Tee	2	
64	2220609	Fitting, Reducer	13	
65	Not Used			
66	Not Used			
67	2751424	Hose	3	
68	2750901	Hose	3	
69	Not Used			
70	2220605	Fitting, Tee	4	
71	2752011	Hose	1	
72	Not Used			
73	2220290	Fitting, Tee	1	
74	2751017	Hose	1	
75	2220608	Fitting, Tee	1	
76	2750778	Hose	1	
77	Not Used			
78	2220417	Fitting, Straight	2	
79	2220727	Fitting, Adapter	1	
80	2220752	Fitting, Tee	1	
81	2220416	Fitting, 90°	1	
82	4640013	Valve, Shuttle	1	
83	Not Used			
84	2220437	Fitting, Reducer	1	
85	4360184	Switch, Pressure	1	
86	0100020	Sealant, Thread (Not Shown)	A/R	
87	2180516	Fitting, Modified	1	
88	2220585	Fitting, 90°	1	
89	2751397	Hose	3	
90	4640216	Valve, Adjustable Restrictor Valve	4	
91	2220677	Fitting, 45°	1	

# SECTION 6 HYDRAULICS

**FIGURE 6-9. HYDRAULIC DIAGRAM - PUMP (HYDRAULIC CONTROLS)**

FIG & ITEM #	PART NUMBER	DESCRIPTION	QTY.	REV.
92	2220657	Fitting, 45		
93	2220052	Fitting, Swivel	1	
94	2220491	Fitting, Straight	1	
95	2220624	Fitting, Reducer	1	
96	2220385	Fitting, Tee	2	
97	Not Used			
98	2220221	Fitting, Reducer	4	
99	2220758	Fitting, Swivel	4	
100	2220396	Fitting, Straight	4	
101	Not Used			
102	2220343	Fitting	4	
103	Not Used			
104	Not Used			
105	Not Used			
106	Not Used			
107	Not Used			
108	4640575	Valve, Check	2	
109	2220909	Orifice (.015)	1	
110	2220920	Fitting, 90°	2	
111	2220654	Fitting, 90°	3	
	2791434	<b>HYDRAULIC DIAGRAM - PUMP (60H) (VARIABLE PARTS)</b>	Ref.	G
	2791580	<b>HYDRAULIC DIAGRAM - PUMP (70H) (VARIABLE PARTS)</b>	Ref.	F
151		Hose Options:	1	
	2752012	Model 60H		
	2752013	Model 70H		
152		Hose Options:	1	
	2752082	Model 60H		
	2752083	Model 70H		
153		Hose Options:	8	
	2752008	Model 60H		
	2752014	Model 70H		

**SECTION 6 HYDRAULICS**

**FIGURE 6-10. HYDRAULIC DIAGRAM - ROTATE (STANDARD PARTS)**

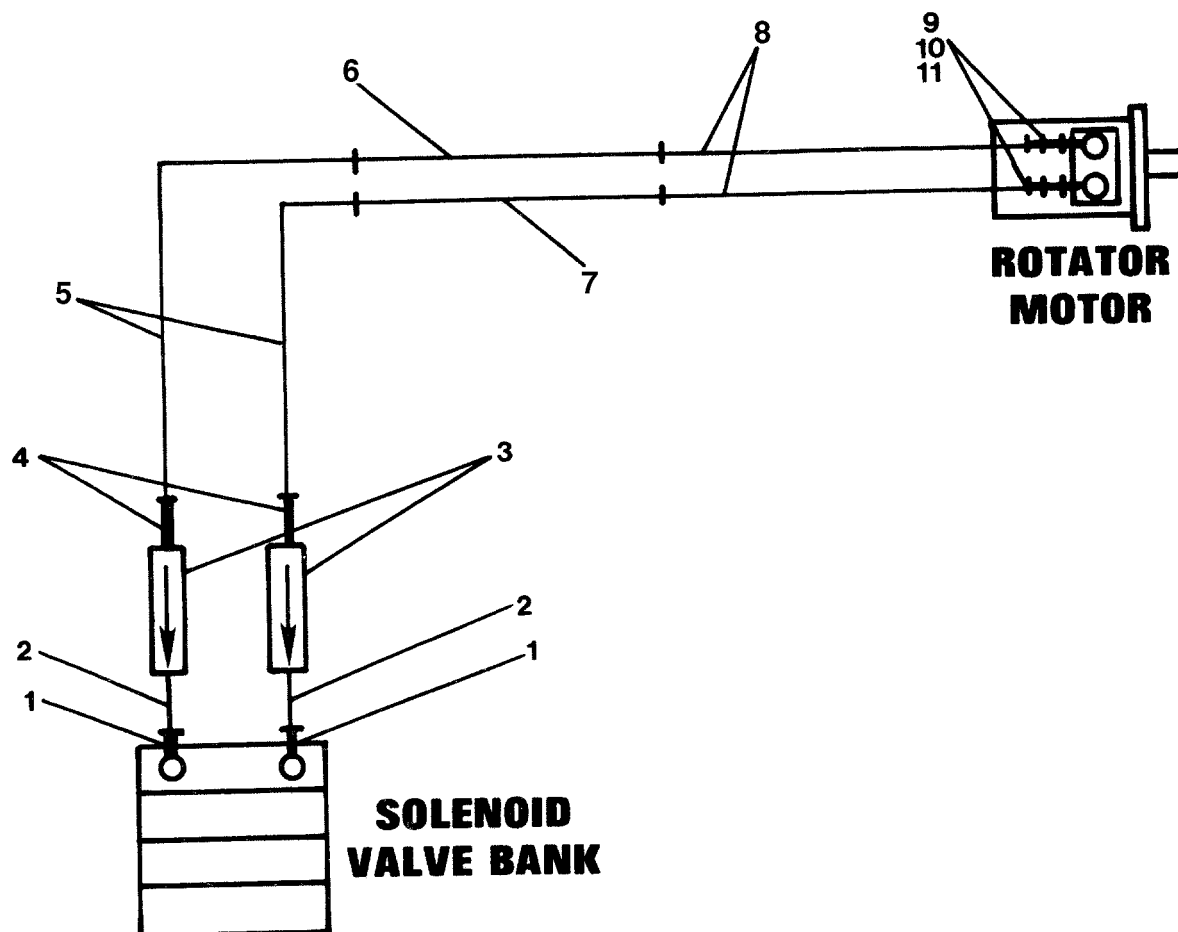



# SECTION 6 HYDRAULICS

**FIGURE 6-10. HYDRAULIC DIAGRAM - ROTATE (STANDARD PARTS)**

FIG & ITEM #	PART NUMBER	DESCRIPTION	QTY.	REV.
	2790957	HYDRAULIC DIAGRAM - ROTATE (60H)	Ref.	D
	2791050	HYDRAULIC DIAGRAM - ROTATE (70H)	Ref.	C
1	2220446	Fitting	2	
2	2220438	Fitting, Nipple	2	
3	4640383	Valve, Restrictor	2	
4	2220414	Fitting, Straight	2	
5		Hose Options:	2	
	2751444	Model 60H		
	2751877	Model 70H		
6		Tube Options:	1	
	4562531	Model 60H		
	4563122	Model 70H		
7		Tube Options:	1	
	4562914	Model 60H		
	4563122	Model 70H		
8		Hose Options:	2	
	2751449	Model 60H		
	4563122	Model 70H		
9	2220609	Fitting, Reducer	2	
10	2220507	Fitting, 90°	2	
11	2220497	Fitting, Straight	2	
12	0100020	Sealant, Thread (Not Shown)	A/R	

# SECTION 6 HYDRAULICS

FIGURE 6-11. HYDRAULIC DIAGRAM - SEQUENCE LINE

## STANDARD CONTROLS

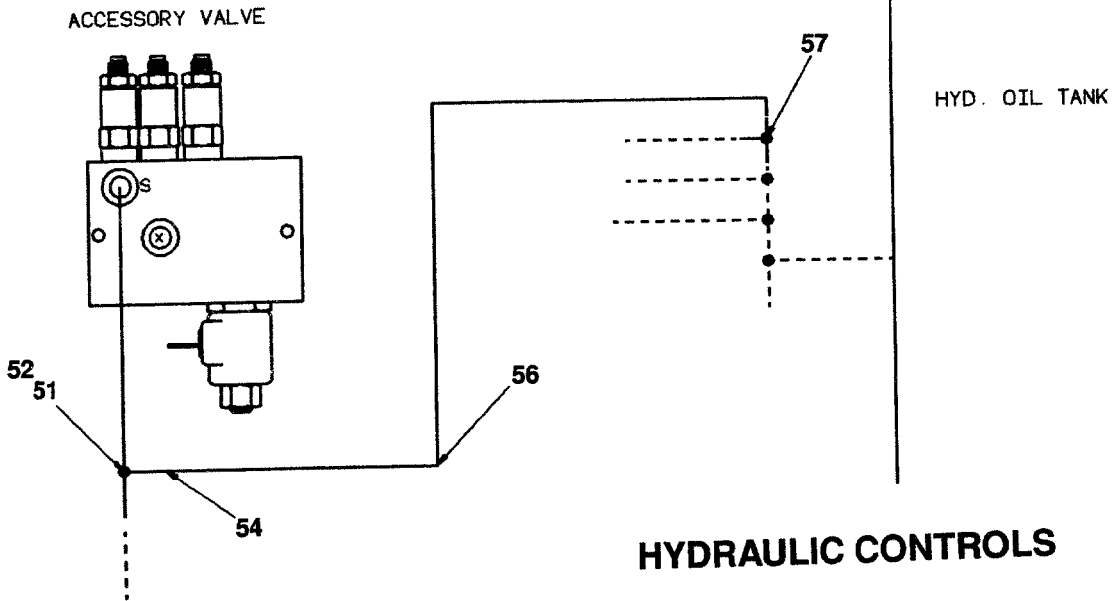
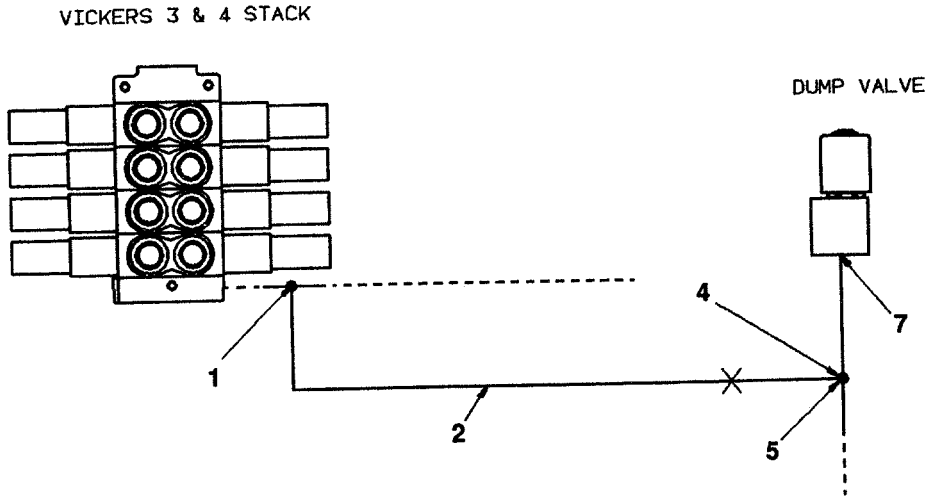

# SECTION 6 HYDRAULICS

**FIGURE 6-11. HYDRAULIC DIAGRAM - SEQUENCE LINE**

FIG & ITEM #	PART NUMBER	DESCRIPTION	QTY.	REV.
	1281353	<b>HYDRAULIC DIAGRAM - SEQUENCE LINE</b>	Ref.	B
	2791698	<b>HYDRAULIC DIAGRAM - SEQUENCE LINE (STANDARD CONTROLS)</b>	Ref.	A
1	2220605	Fitting, Tee	1	
2	2750889	Hose	1	
3	Not Used			
4	2220909	Orifice (.015)	1	
5	2220605	Fitting, Tee	1	
6	Not Used			
7	2220582	Fitting, Straight	1	
	2791700	<b>HYDRAULIC DIAGRAM - SEQUENCE LINE (HYDRAULIC CONTROLS)</b>	Ref.	B
51	2220582	Fitting, Straight	1	
52	2220861	Fitting, Tee	1	
53	Not Used			
54	2220909	Orifice (.015)	1	
55	Not Used			
56	2751015	Hose	1	

**SECTION 6 HYDRAULICS**

**FIGURE 6-12. HYDRAULIC DIAGRAM - STEER**

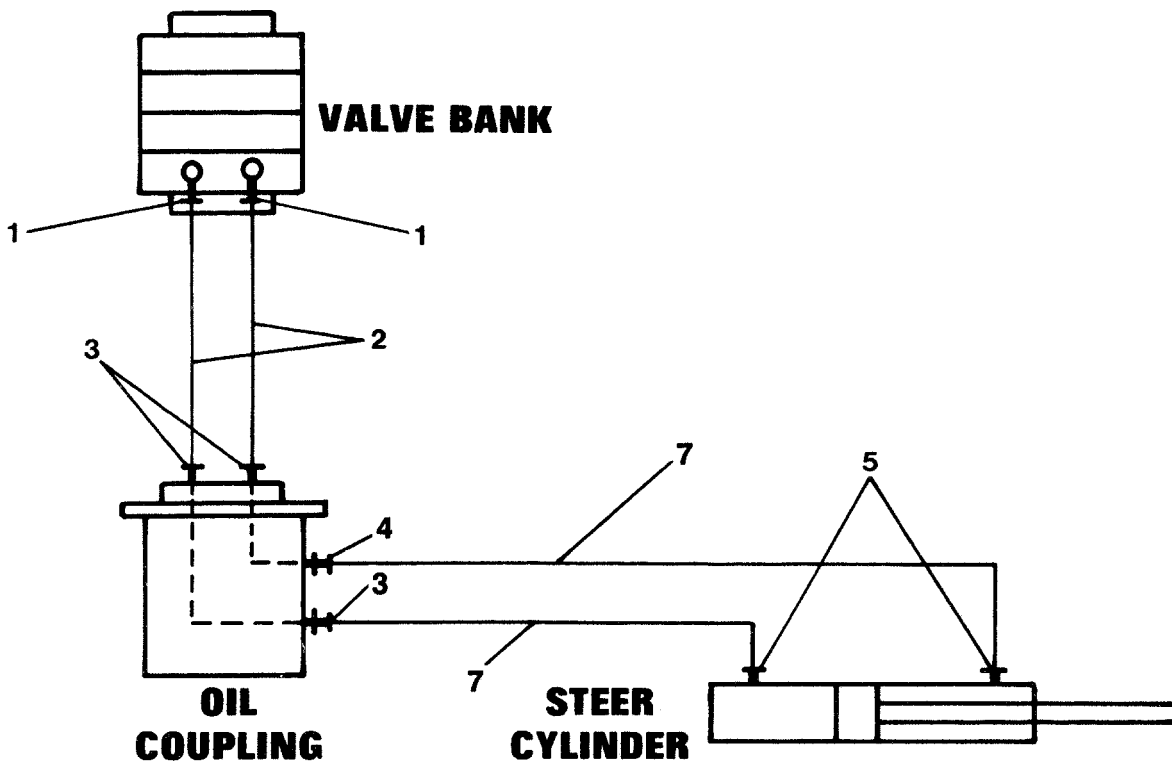

# SECTION 6 HYDRAULICS

**FIGURE 6-12. HYDRAULIC DIAGRAM - STEER**

FIG & ITEM #	PART NUMBER	DESCRIPTION	QTY.	REV.
		<b>HYDRAULIC DIAGRAM - STEER</b>	Ref.	
	2790947	<b>HYDRAULIC DIAGRAM - STEER (FIXED AXLE)</b>	Ref.	C
	2790973	<b>HYDRAULIC DIAGRAM - STEER (OSCILLATING AXLE)</b>	Ref.	D
1	2220468	Fitting, Straight	2	
2	2751016	Hose	2	
3		Fitting Options:	2	
	2220417	Fitting, Straight (Fixed Axle)		
	2220496	Fitting, 45° (Oscillating Axle)		
4		Fitting, Straight Options:	2	
	2220417	Fixed Axle		
	2220414	Oscillating Axle		
5	2220416	Fitting, 90°	2	
6	0100020	Sealant, Thread (Not Shown)	A/R	
7		Hose Options:	2	
	2750894	Fixed Axle		
	2750897	Oscillating Axle		

## SECTION 6 HYDRAULICS

FIGURE 6-13. HYDRAULIC DIAGRAM - SWING

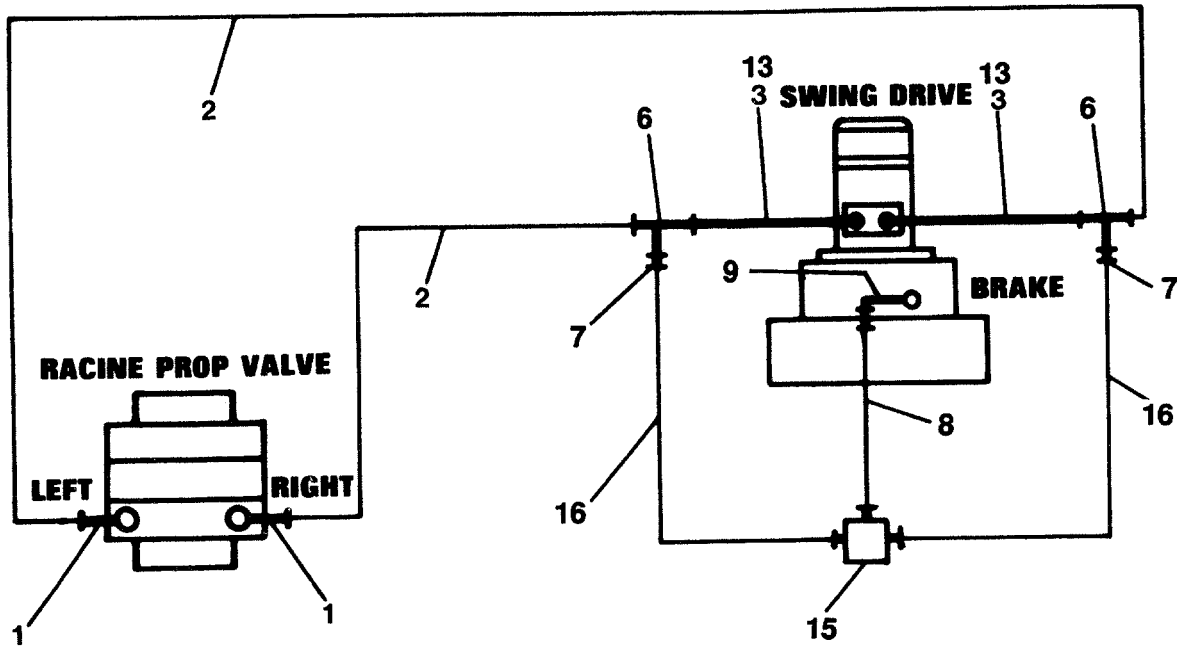

# SECTION 6 HYDRAULICS

**FIGURE 6-13. HYDRAULIC DIAGRAM - SWING**

FIG & ITEM #	PART NUMBER	DESCRIPTION	QTY.	REV.
	2791248	<b>HYDRAULIC DIAGRAM - SWING</b>	Ref.	C
1	2220577	Fitting, Straight	2	
2	2750785	Hose	2	
3	2220344	Fitting, Straight	2	
4	Not Used			
5	Not Used			
6	2220635	Fitting, Tee	2	
7	2220609	Fitting, Straight	2	
8	2750900	Hose	1	
9	2220466	Fitting, 90°	1	
10	Not Used			
11	Not Used			
12	Not Used			
13	0100020	Sealant, Thread (Not Shown)	A/R	
14	Not Used			
15	4640574	Valve, Shuttle	1	
16	2750902	Hose	2	

# SECTION 6 HYDRAULICS

FIGURE 6-14. HYDRAULIC DIAGRAM - TELESCOPE

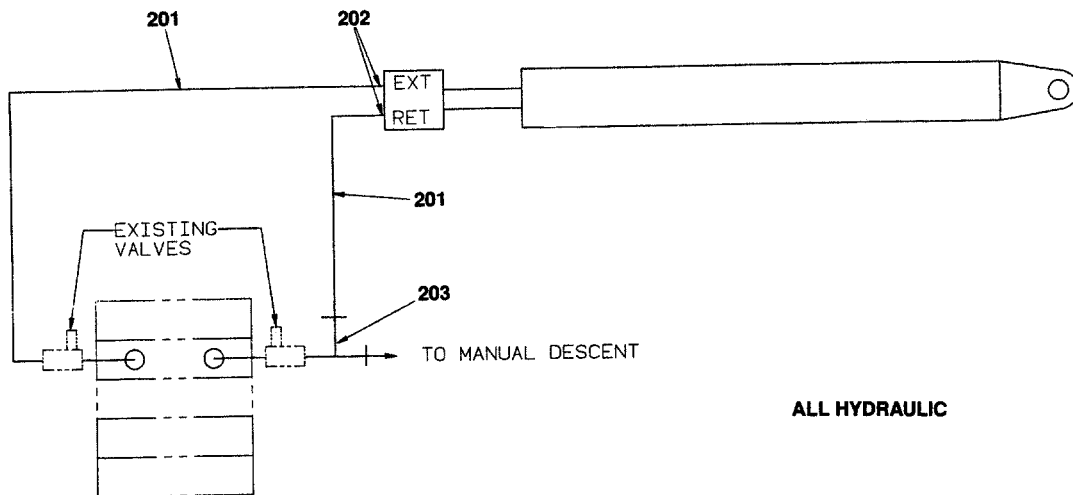
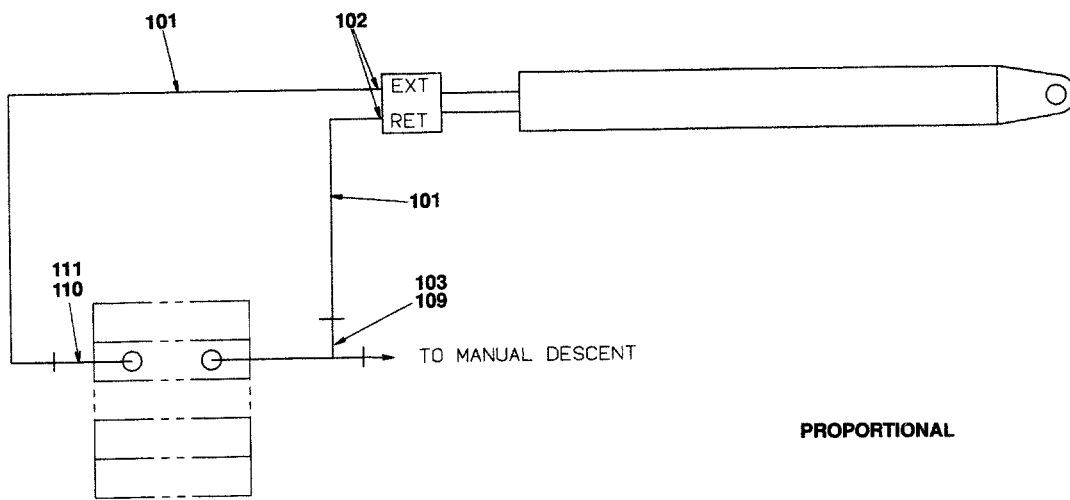
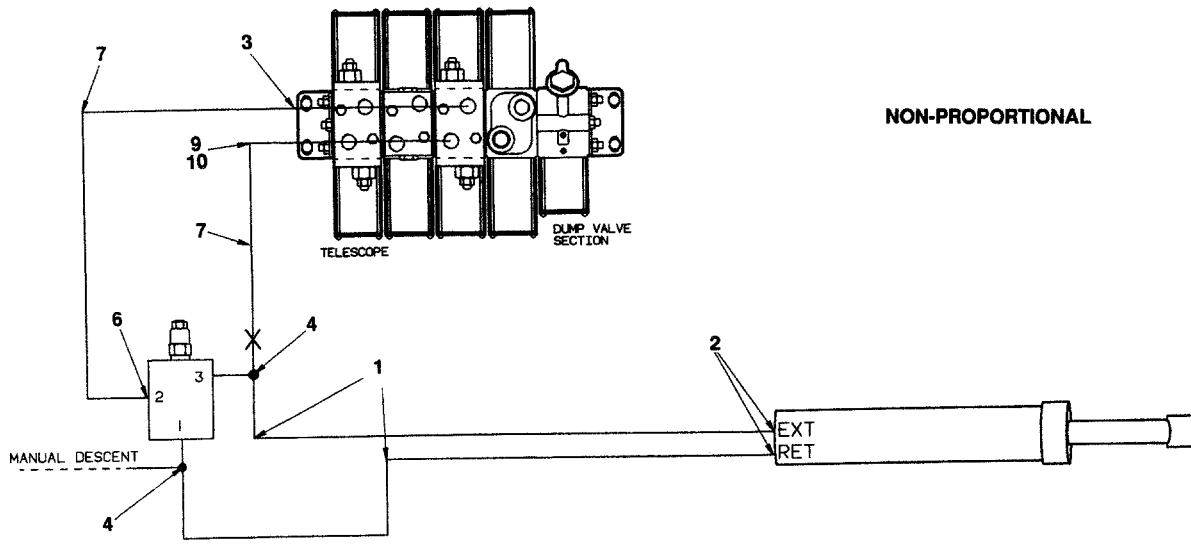



# SECTION 6 HYDRAULICS

**FIGURE 6-14. HYDRAULIC DIAGRAM - TELESCOPE**

FIG & ITEM #	PART NUMBER	DESCRIPTION	QTY.	REV.
		<b>HYDRAULIC DIAGRAM - TELESCOPE</b>	Ref.	
	2791257	<b>HYDRAULIC DIAGRAM - TELESCOPE (STANDARD NON-PROPORTIONAL CONTROLS)</b>	Ref.	F
1	2751114	Hose	2	
2	2220343	Fitting, Straight	2	
3	2220372	Fitting, Straight	1	
4	2220606	Fitting, Tee	2	
5	Not Used			
6	2220371	Fitting, Straight	1	
7	2750921	Hose	2	
8	0100020	Sealant, Thread (Not Shown)	A/R	
9	2180479	Fitting, Modified	1	
10	2180486	Orifice (1/8")	1	
11	Not Used			
12	0100011	Loctite (Not Shown)	A/R	
	2791254	<b>HYDRAULIC DIAGRAM - TELESCOPE (STANDARD PROPORTIONAL CONTROLS)</b>	Ref.	D
101	2751114	Hose	2	
102	2220343	Fitting, Straight	2	
103	2220577	Fitting, Straight	1	
104	Not Used			
105	Not Used			
106	Not Used			
107	Not Used			
108	0100020	Sealant, Thread (Not Shown)	A/R	
109	2220635	Fitting, Tee	1	
110	2180780	Orifice (5/32")	1	
111	2180384	Fitting, Modified	1	
	2792051	<b>HYDRAULIC DIAGRAM - TELESCOPE (HYDRAULIC CONTROLS)</b>	Ref.	-
201	2751114	Hose	2	
202	2220343	Fitting, Straight	2	
203	2220635	Fitting, Tee	1	
204	0100020	Sealant, Thread (Not Shown)	A/R	

## SECTION 6 HYDRAULICS

FIGURE 6-15. HYDRAULIC DIAGRAM LIST

FIG & ITEM #	PART NUMBER	DESCRIPTION
6—15		<p><b>HYDRAULIC DIAGRAM LIST</b></p> <p><b>Note: Diagrams with asterisk (*) are shown in the following pages. Information on Diagrams not shown is available from JLG Service/Parts Departments.</b></p> <p><b>Axle Lockout Hydraulic Diagrams:</b></p> <p>2790974 Prior to May 1992 2791899* May 1992 to Present</p> <p><b>Drive Hydraulic Diagrams:</b></p> <p><b>Racine Proportional Valve Machines:</b></p> <p>2790954 2WD Single Speed Gear Pump (Prior to September 1986) 2791174 2WD Single Speed Gear Pump (September - 1986 to Mid 1987) 2790981 2WD Two Speed Gear Pump (Prior to September 1986) 2791175 2WD Two Speed Gear Pump (September 1986 to Mid 1987) 2791135 4WD</p> <p><b>Vickers Proportional Valve Machines:</b></p> <p>2791264 2WD (Prior to May 1992) 2791894* 2WD/2WS (May 1992 to Present) 2791896 2WD/4WS 2791297 4WD (Prior to August 1987) 2791341 4WD (August 1987 to May 1992) 2791895* 4WD/2WS (May 1992 to Present) 2791897 4WD/4WS 2791685 4WD (S/N's 13914, 13915, 13924, 13925 and 13926 Only)</p> <p><b>Level Hydraulic Diagrams:</b></p> <p><b>60H:</b></p> <p>2790956 Prior to May 1993 2792054* May 1993 to Present</p> <p><b>60H+6:</b></p> <p>2791232 Fixed Platform (Prior to May 1993) 2792053 Fixed Platform (May 1993 to Present) 2791231 Rotating Platform (Prior to May 1993) 2792052* Rotating Platform (May 1993 to Present)</p> <p><b>70H:</b></p> <p>2791051 Prior to May 1993 2792066* May 1993 to Present 2792147 S/N's 6099 and 7020 only</p> <p><b>Lift Hydraulic Diagrams:</b></p> <p>2790945 Machines with Racine Proportional Valves 2791252 Machines with Vickers Proportional Valves</p> <p>2790946* <b>Manual Descent Hydraulic Diagram</b></p> <p><b>Oil Cooler Hydraulic Diagrams:</b></p> <p>2791448 Oil Cooler at Rear of T/T 0254853 Oil Cooler Inside T/T</p>

# SECTION 6 HYDRAULICS

FIG & ITEM #	PART NUMBER	DESCRIPTION
		<b>Pump Hydraulic Diagrams:</b>
		<b>Racine Proportional Valves and Standard Controls:</b>
	2790953	Standard Gear Pump Machines
	2791001	Gear Pump Machines with Steering Wheel
	2790985	Gear Pump Machines with Oil Cooler
	2791003	Gear Pump Machines with Steering Wheel and Oil Cooler
	2791004	Piston Pump Machines with Steering Wheel and Oil Cooler
		<b>Vickers Proportional Valves and Standard Controls:</b>
	2791263	Standard Machines without Steering Wheel
	2791266	Standard Machines with Steering Wheel
	2792075	Machines with Large Auxiliary Pump
	1281012*	<b>Vickers Proportional Valves and Hydraulic Controls:</b>
	2791434	60H with Ford or Deutz Engine
	2791756	60H with Deutz Engine (Dow Chemical)
	2791451	60H with Wisconsin Engine
	2791755	60H with Wisconsin Engine (Dow Chemical)
	2791580*	70H with Ford or Deutz Engine
	2791589	70H with Wisconsin Engine
		<b>Rotate Hydraulic Diagrams:</b>
	2790957	60H without Steering Wheel
	2790962	60H with Steering Wheel
	2791050*	70H
	2792146	70H S/N's 6099 and 7020 Only
		<b>Schematic - Hydraulic:</b>
	2791898	Standard Controls
	2791928	Hydraulic Controls
	1281353*	<b>Sequence Hydraulic Diagrams:</b>
	2791698*	Standard Controls
	2791700*	Hydraulic Controls
		<b>Steer Hydraulic Diagrams:</b>
	2790947*	2WS Fixed Axle
	2790973*	2WS Oscillating Axle
	2791006	2WS Fixed Axle and Steering Wheel
	2791005	2WS Oscillating Axle and Steering Wheel
	2791900	4WS
		<b>Swing Hydraulic Diagrams:</b>
	2790950	Racine Proportional Valve Machines
	2791248*	Vickers Proportional Valve Machines
		<b>Telescope Hydraulic Diagrams:</b>
	2790949	Machines without Prop Tele (Racine Proportional Valves)
	2791257*	Machines without Prop Tele (Vickers Proportional Valves)
	2791057	Machines with Prop Tele (Racine Proportional Valves)
	2791254*	Machines with Prop Tele (Vickers Proportional Valves)
	2792051*	Machines with Hydraulic Controls

# SECTION 6 HYDRAULICS

## SECTION 6 HYDRAULICS

FIG & ITEM #	PART NUMBER	DESCRIPTION
	2791032	Tow Hydraulic Diagram
	2791881	Valjar Hydraulic Pressure Chart

# SECTION 7 ELECTRICAL

<b>TABLE OF CONTENTS</b>		
<b>FIGURE</b>	<b>DESCRIPTION</b>	<b>PAGE</b>
7-1	ELECTRICAL DIAGRAM LIST .....	7-2
7-2	WIRING DIAGRAM - DUAL FUEL (Ford & Wisconsin Engines) .....	7-13
7-3	WIRING DIAGRAM - 110V GENERATOR (Deutz Engine) .....	7-14
7-4	WIRING DIAGRAM - 110V GENERATOR (Ford Engine) .....	7-15
7-5	WIRING DIAGRAM - PLATFORM CONSOLE STANDARD CONTROLS .....	7-16
7-6	WIRING DIAGRAM - PLATFORM CONSOLE HYDRAULIC CONTROLS .....	7-19
7-7	WIRING DIAGRAM - STANDARD (Deutz & Wisconsin Engines Standard Controls) .....	7-20
7-8	WIRING DIAGRAM - STANDARD (Deutz & Wisconsin Engines Hydraulic Controls) .....	7-22
7-9	WIRING DIAGRAM - STANDARD (Ford Engine Standard Controls) .....	7-24
7-10	WIRING DIAGRAM - STANDARD (Ford Engine Hydraulic Controls) .....	7-26

# SECTION 7 ELECTRICAL

FIG & ITEM #	PART NUMBER	DESCRIPTION	QTY.	REV.
7-1		<b>ELECTRICAL DIAGRAM LIST</b>	Ref.	
		<b>Note: Diagrams with asterisk (*) are shown in the following pages. Diagrams not shown are available from the JLG Service Department.</b>		
		<b>Alarm Wiring Diagrams</b>	Ref.	
		<b>Standard and Hydraulic Controls (Prior to April 1992)</b>		
	4931472/1280555	<b>Back-up Alarm Wiring Diagram</b>	Ref.	A/B
	4931468/1280555	<b>Descent Alarm Wiring Diagram</b>	Ref.	A/B
	0239055	<b>Motion Alarm Wiring Diagram</b>	Ref.	A
	4931520/1280555	<b>Swing Alarm Wiring Diagram</b>	Ref.	A/B
	4931470/1280555	<b>Tilt Alarm Wiring Diagram</b>	Ref.	A/B
	4931399/1280555	<b>Travel Alarm Wiring Diagram</b>	Ref.	B/B
	3990010	Diode - 6 Amp	A/R	
	3740049	Relay - SPST	1	
		<b>Standard Controls (April 1992 to April 1993)</b>		
	4932507/1281840	<b>Back-up Alarm Wiring Diagram</b>	Ref.	—/—
	4932507/1281840	<b>Descent Alarm Wiring Diagram</b>	Ref.	—/—
	4932508/1281840	<b>Motion Alarm Wiring Diagram</b>	Ref.	—/—
	4932507/1281840	<b>Swing Alarm Wiring Diagram</b>	Ref.	—/—
	0253077	<b>Tilt Alarm Wiring Diagram</b>	Ref.	—
	4932507/1281840	<b>Travel Alarm Wiring Diagram</b>	Ref.	—/—
	0610091	Card, Circuit	1	
	3740049	Relay	1	
	3990010	Diode - 6 Amp	A/R	
	0140026	Alarm (Tilt Only - Located at Console)	A/R	
		<b>Standard Controls (April 1993 to Present)</b>		
	4932637/1282091	<b>Back-up Alarm Wiring Diagram</b>	Ref.	2/C
	4932637/1282091	<b>Descent Alarm Wiring Diagram</b>	Ref.	2/C
	4932639/1282091	<b>Motion Alarm Wiring Diagram</b>	Ref.	2/C
	4932637/1282091	<b>Swing Alarm Wiring Diagram</b>	Ref.	2/C
	0253077	<b>Tilt Alarm Without Cutout Wiring Diagram</b>	Ref.	-
	0254203	<b>Tilt Alarm With Cutout Wiring Diagram</b>	Ref.	B
	4932637/1282091	<b>Travel Alarm Wiring Diagram</b>	Ref.	2/C
	3740049	Relay	1	
	3990010	Diode - 6 Amp	A/R	
	0610104	Card, Circuit	A/R	
	0140026	Alarm (Tilt Alarm Only - Located at Console)	A/R	
	1540002	Capacitor (Tilt Alarm Only - Located at Console)	1	
	4360274	Switch, Push Button (Tilt Alarm Only - Located at Console)	1	
	3252321	Nameplate - Override (Tilt Alarm Only - Located at Console)	1	
		<b>Hydraulic Controls (April 1992 to Present)</b>		
	4932347/1281503	<b>Back-up Alarm Wiring Diagram</b>	Ref.	-/-
	4932346/1281503	<b>Descend Alarm Wiring Diagram</b>	Ref.	-/-
	4932345/1281503	<b>Motion Alarm Wiring Diagram</b>	Ref.	-/-
	4932349/1281503	<b>Swing Alarm Wiring Diagram</b>	Ref.	-/-
	0253077	<b>Tilt Alarm Wiring Diagram</b>	Ref.	-

# SECTION 7 ELECTRICAL

FIG & ITEM #	PART NUMBER	DESCRIPTION	QTY.	REV.
	4932348/1281503	<b>Travel Alarm Wiring Diagram</b>	Ref.	-/-
	4360184	Switch, Pressure	1	
	3740049	Relay	1	
	3990010	Diode - 6 Amp	A/R	
	0140026	Alarm (Tilt Alarm Only - Located at Console)	A/R	
	4931866	<b>Battery Disconnect Wiring Diagram (U/L Listed)</b>	Ref.	B
	2400008	Fuse - 3/4 Amp	1	
	4360085	Switch, Select	1	
	4360075	Switch, Ignition	2	
		<b>Beacon/Strobe Light Wiring Diagrams</b>	Ref.	
	4931085	<b>Beacon Light - Platform Mounted (Prior to September 1991)</b>	Ref.	—
	4931740	<b>Beacon Light - Platform Mounted (September 1991 to Present)</b>	Ref.	A
	4931674	<b>Beacon/Strobe Light - Turntable Mounted (Prior to February 1994)</b>	Ref.	—
	4932673	<b>Beacon/Strobe Light - Turntable Mounted (February 1994 to Present)</b>	Ref.	3
		<b>Boom Cables and Harnesses</b>	Ref.	
	0800392	<b>60H With Standard Controls</b>	Ref.	W
	1060229	Cable, Electrical - 16/30	76.5 Ft.	
	1060012	Cable, Electrical - 12/4	77.3 Ft.	
	4920613	Harness - 110V (Prior to October 1993)	1	
	1060268	Cable, Electrical - 110V 12/3 (October 1993 to Present)	78 Ft.	
	0800577	<b>60H With Hydraulic Controls</b>	Ref.	I
	1060039	Cable, Electrical - 16/24	76.5 Ft.	
	1060012	Cable, Electrical - 12/4	77.3 Ft.	
	4920613	Harness - 110V (Prior to October 1993)	1	
	1060268	Cable, Electrical - 110V 12/3 (October 1993 to Present)	78 Ft.	
	0800505	<b>60H+6</b>	Ref.	E
	1060229	Cable, Electrical - 16/30	88.5 Ft.	
	1060012	Cable, Electrical - 12/4	89.3 Ft.	
	4920865	Harness - 110V (Prior to October 1993)	1	
	1060268	Cable, Electrical - 110V 12/3 (October 1993 to Present)	90 Ft.	
	0800418	<b>70H With Standard Controls</b>	Ref.	L
	1060229	Cable, Electrical - 16/30	88.5 Ft.	
	1060012	Cable, Electrical - 12/4	89.3 Ft.	
	4920616	Harness - 110V (Prior to October 1993)	1	
	1060268	Cable, Electrical - 110V 12/3 (October 1993 to Present)	90 Ft.	
	0800631	<b>70H With Hydraulic Controls</b>	Ref.	E
	1060229	Cable, Electrical - 16/30	88.5 Ft.	
	1060012	Cable, Electrical - 12/4	89.3 Ft.	
	4920416	Harness - 110V (Prior to October 1993)	1	
	1060268	Cable, Electrical - 110V 12/3 (October 1993 to Present)		

# SECTION 7 ELECTRICAL

FIG & ITEM #	PART NUMBER	DESCRIPTION	QTY.	REV.
	4931444	<b>Dual Fuel Wiring Diagram (Prior to May 1995)</b>	Ref.	F
	4921305	Harness	1	
	4360201	Switch, Toggle (Located at Ground Control Box)	1	
	4932813*	<b>Dual Fuel Wiring Diagram (May 1995 to Present)</b>	Ref.	-
	4921763	Harness	1	
	4360201	Switch, Toggle (Located at Ground Control Box)	1	
	4931671	<b>Engine Distress Wiring Diagram - Deutz Engines (Prior to September 1994)</b>	Ref.	B
	4360179	Switch, Temperature	1	
	4360089	Flasher	1	
	3740013	Relay	1	
	4360065	Switch, Pressure	1	
	2920034	Lamp (Located at Platform Console)	1	
	3251695	Nameplate - Engine Distress	1	
	0255152	<b>Engine Distress Wiring Diagram - Deutz Engines (September 1994 to Present)</b>	Ref.	3
	2920026	Lamp, Indicator	1	
	2920029	Bulb, Light	1	
	4360065	Switch, Oil Pressure	1	
	4360179	Switch, Temperature	1	
	3740099	Relay	1	
	4931598	<b>Engine Distress Wiring Diagram - Ford Engines (Prior to July 1994)</b>	Ref.	B
	3740013	Relay	1	
	4360089	Flasher	1	
	2920034	Lamp (Located at Platform Console)	1	
	3251695	Nameplate - Engine Distress	1	
	4360182	Switch, Oil Pressure	1	
	4360157	Switch, Water Temperature	1	
	0255058	<b>Engine Distress Wiring Diagram - Ford Engines (July 1994 to Present)</b>	Ref.	B
	2920026	Lamp, Indicator	1	
	2920029	Bulb, Light	1	
	4360182	Switch, Oil Pressure	1	
	4360157	Switch, Water Temperature	1	
	3740044	Relay	1	
	0251683	<b>Engine Run Light Wiring Diagram - Deutz Engines</b>	Ref.	B
	2920027	Lamp, Indicator	1	
	2920029	Bulb, Light	1	
	4360037	Switch, Pressure	1	
	1702528	Decal - Engine Run	1	



# SECTION 7 ELECTRICAL

FIG & ITEM #	PART NUMBER	DESCRIPTION	QTY.	REV.
	4932892	<b>Engine Shut-Down Wiring Diagram - Deutz Engines</b>	Ref.	—
	4931640	<b>Extend-A-Reach Wiring Diagram</b>	Ref.	C
	4360202	Switch, Toggle (Located at Both Control Boxes)	2	
	3251747	Nameplate - Articulate (When Required)	2	
	0250150	<b>Fuel Indicator Lamp At Console Wiring Diagram</b>	Ref.	-
	4360265	Switch, LPG	1	
	2920015	Lamp	1	
	3251929	Nameplate - LP	1	
	4932064	<b>4WD Wiring Diagram for 60H With 3 Flow Dividers and Special Auxiliary Pump (S/N's 13915, 13916, 13924, 13925 and 13926)</b>	Ref.	-
	4932362/ 1281526	<b>4WS Wiring Diagram</b>	Rev.	A/C
	1060042	Cable, Electrical - 16/5	15 Ft.	
	4931693*	<b>Generator Wiring Diagram - 110V (Deutz)</b>	Ref.	E
	3990001	Diode - 3.5 Amp	1	
	3740049	Relay	1	
	4360294	Breaker, Circuit - 30 Amp	1	
	0250294/ 1281219	<b>Generator Wiring Diagram - 110V With GFI Receptacle and Weatherproof Box (Deutz)</b>	Ref.	D/D
	4360075	Switch	1	
	3251476	Nameplate - On/Off	1	
	2920026	Lamp	1	
	2920029	Bulb, Light	1	
	4460349	Receptacle, GFI	1	
	4060700	Shield, Cover	1	
	1060308	Cable, Electrical - 12/3	78 Ft.	
	4931314/4931692	<b>Generator Wiring Diagram - 110V (Ford) (Prior to February 1995)</b>	Ref.	C/D
	3990001	Diode - 3.5 Amp	2	
	3740049	Relay	1	
	4360294	Breaker, Circuit - 30 Amp	1	
	4932806*	<b>Generator Wiring Diagram - 110V (Ford) (February 1995 to Present)</b>	Ref.	3
	3990010	Diode - 6 Amp	3	
	4360294	Breaker, Circuit - 30 Amp	1	

# SECTION 7 ELECTRICAL

FIG & ITEM #	PART NUMBER	DESCRIPTION	QTY.	REV.
	0250396	<b>Generator Wiring Diagram - 110V U/L Listed (Ford)</b>	Ref.	B
	4360075	Switch, Toggle	1	
	3251476	Nameplate - On/Off	1	
	2920026	Lamp	1	
	2920029	Bulb, Light	1	
	4460349	Receptacle	1	
	0239244	Generator Assembly	1	
	1060308	Cable, Electrical - 12/3	78 Ft.	
	4932736	<b>Ground Control Box Wiring Diagram - Prop Tele</b>	Ref.	-
	4931691	<b>Heaters Wiring Diagram (Deutz) (Prior to June 1995)</b>	Ref.	D
	1060300	Cable, Electrical - 16/3	50 Ft.	
		Cable, Electrical - 12/4	20 Ft.	
	1060309	Prior to July 1995		
	1060515	July 1995 to Present		
	4932469	<b>Heaters Wiring Diagram (Deutz) (June 1995 to Present)</b>	Ref.	4
	1060016	Cable, Electrical - 16/3	40 Ft.	
	1060494	Cable, Electrical - 12/4	10 Ft.	
	4931411	<b>Heaters Wiring Diagram (Ford)</b>	Ref.	3
	1060016	Cable, Electrical - 16/3	30 Ft.	
	Use 1060515	Cable, Electrical - 12/4 (was p/n 1060012)	10 Ft.	
	4931680	<b>Lights Wiring Diagram - Headlight and Taillights (Prior to March 1993)</b>	Ref.	D
	0254084/1282112	<b>Lights Wiring Diagram - Headlights and Taillights (March 1993 to Present)</b>	Ref.	A/C
	4932080	<b>Lights Wiring Diagram - Headlights and Taillights Front and Rear</b>	Ref.	
	4360199	Switch, Toggle	1	
	2920110	Headlight	A/R	
	2920113	Light, Stop/Turn/Tail	A/R	
	3740080	Relay	1	
	0254096	<b>Lights Wiring Diagram - Turn Signals</b>	Ref.	A
	2920113	Light, Stop/Turn/Tail	2	
	4360089	Flasher	1	
	0255274	<b>Low Oil Pressure Shutdown Wiring Diagram - Deutz Engines</b>	Ref.	4
	2920026	Lamp, Indicator	1	
	2920029	Bulb, Light	1	
	4360065	Switch, Oil Pressure	1	
	3740049	Relay (In Platform Console Box)	1	
	3990010	Diode - 6 Amp	1	
	3740080	Relay (In Platform Console Box)	1	

# SECTION 7 ELECTRICAL

FIG & ITEM #	PART NUMBER	DESCRIPTION	QTY.	REV.
	4932737	<b>LP Gas Only Wiring Diagram</b>	Ref.	—
	4921305	Harness - LP Gas	1	
	4931261	<b>Oil Cooler Wiring Diagram - Rear of Turntable</b>	Ref.	A
	0254853	<b>Oil Cooler Wiring Diagram - Inside Turntable</b>	Ref.	5
	2400005	Fuse - 20 Amp	1	
	3740080	Relay	1	
		<b>Platform Wiring Diagrams</b>	Ref.	
		<b>Racine Prop Valve Machines:</b>		
	4931334	<b>Wiring Diagram - Solenoid Throttle and Without Prop Tele (Prior to August 1985)</b>	Ref.	E
	4931422	<b>Wiring Diagram - Adeco Throttle and Without Prop Tele (August 1985 to Mid 1987)</b>	Ref.	B
	4931395/ 4931392	<b>Wiring Diagram - Solenoid Throttle and With Prop Tele (Prior to August 1985)</b>	Ref.	
	4931424	<b>Wiring Diagram - Adeco Throttle and With Prop Tele (August 1985 to Mid 1987)</b>	Ref.	A
	4360209	Breaker, Circuit - 20 Amp	1	
	1540002	Capacitor - 1000mf/25VDC	1	
	3990010	Diode - 6 Amp		
		<b>Vickers Prop Valve Machines With Standard PQ Controllers and Without Prop Tele:</b>		
	4931625	<b>Wiring Diagram - 2WD (Mid 1987 to September 1991)</b>	Ref.	5
	4931667	<b>Wiring Diagram - 4WD Only (Mid 1987 to September 1991)</b>	Ref.	C
	4932432/ 1281682*	<b>Wiring Diagram - 2WS With Creep (September 1991 to Present)</b>	Ref.	2/-
	9983524	<b>Wiring Diagram - 2WS With Creep and With 2 Steer Switches</b>	Ref.	—
	4932433/ 1281682*	<b>Wiring Diagram - 4WS With Creep (September 1991 to Present)</b>	Ref.	2/-
	3990010	Diode - 6 Amp	A/R	
	1540002	Capacitor - 1000mf/25VDC	1	
	1060012	Cable, Electrical - 12/4 (To Footswitch) (Prior to July 1989)	9 Ft.	
	1060515	Cable, Electrical - 12/4 (To Footswitch) (July 1989 to Present)	9 Ft.	
		<b>Vickers Prop Valve Machines With Standard PQ Controllers and With Prop Tele:</b>		
	4931672	<b>Wiring Diagram - 2WD (Mid 1987 to September 1991)</b>	Ref.	B
	4931632/ 4931670	<b>Wiring Diagram - 4WD (Mid 1987 to September 1991)</b>	Ref.	-/A
	4932435/ 1281682*	<b>Wiring Diagram - 2WS With Creep (September 1991 to Present)</b>	Ref.	2/-
	9983524	<b>Wiring Diagram - 2WS With Creep and With 2 Steer Switches</b>	Ref.	—
	4932436/ 1281682*	<b>Wiring Diagram - 4WS With Creep (September 1991 to Present)</b>	Ref.	2/-
	3990010	Diode - 6 Amp	A/R	

# SECTION 7 ELECTRICAL

FIG & ITEM #	PART NUMBER	DESCRIPTION	QTY.	REV.
	1540002	Capacitor - 1000mf/25VDC	1	
	Use 1060515	Cable, Electrical - 12/4 (To Footswitch) (was p/n 1060012)	9 Ft.	
		<b>Vickers Prop Valve Machines With Hydraulic PQ Controllers:</b>		
	4931842	<b>Wiring Diagram</b>	Ref.	4
	Use 1060515	Cable, Electrical - 12/4 (was p/n 1060012)	7 Ft.	
	4921132	Harness, Capacitor	1	
		<b>Vickers Prop Valve Machines With OEM Controllers:</b>		
	4931665/ 1280803	<b>Wiring Diagram - 2WD Without Prop Tele</b>	Ref.	B/—
	4931677	<b>Wiring Diagram - 4WD Without Prop Tele</b>	Ref.	A
	4931666/ 1280804	<b>Wiring Diagram - 2WD With Prop Tele</b>	Ref.	-/-
	4931676	<b>Wiring Diagram - 4WD With Prop Tele</b>	Ref.	—
	4360216	Breaker, Circuit - 30 Amp	1	
	1060012	Cable, Electrical - 12/4	7 Ft.	
	4920630	Harness, Capacitor	1	
		<b>Platform Bumper Wiring Diagram</b>	Ref.	
	1282197	<b>Wiring Diagram - Chain Mounted (Soft-Touch) Bumper</b>	Ref.	H
	4932059	<b>Wiring Diagram - Welded on Bumper</b>	Ref.	A
		<b>Platform Work Lights Wiring Diagram</b>	Ref.	
	2900068	<b>Wiring Diagram (Prior to November 1992)</b>	Ref.	F
	2920013	Worklight	2	
	0253987	<b>Wiring Diagram (November 1992 to Present)</b>	Ref.	C
	0254748	<b>Wiring Diagram with Padded Platform</b>	Ref.	-
	2920111	Worklight	2	
	4931713	<b>Pressure Overload Switches Wiring Diagram (S/N 10829 and 10830)</b>	Ref.	G
	3740020	Relay - Time Delay1		
	3740016	Relay	1	
	2920026	Lamp - Red	1	
	2920029	Bulb, Light	1	
	0140026	Horn	1	
	3251600	Nameplate	1	
		<b>Remote Control Wiring Diagrams:</b>	Ref.	
	4931736	<b>Wiring Diagram (Drive and Steer Functions on a Cord)</b>	Ref.	B
	1060042	Cable, Electrical - 16/5	25 Ft.	
	3990010	Diode - 6 Amp	4	
	4932084	<b>Wiring Diagram (Complete Ground Controls on a Cord)</b>	Ref.	-
	4360232	Breaker, Circuit - 15 Amp	1	
	3730095	Resistor 7.5 ohm/10 Watts	1	

# SECTION 7 ELECTRICAL

FIG & ITEM #	PART NUMBER	DESCRIPTION	QTY.	REV.
	4932079	<b>Wiring Diagram (Junction Box Used with 4932084 Wiring)</b>	Ref.	A
	1060229	Cable, Electrical - 16/30	139 Ft.	
	1060229	Cable, Electrical - 16/30	16 Ft.	
		Cable, Electrical - 12/4 Options:	14 Ft.	
	1060309	Prior to July 1995		
	1060515	July 1995 to Present		
	3990010	Diode - 6 Amp	12	
		<b>Standard Wiring Diagrams (Racine Valve Machines)</b>	Ref.	
		<b>Wiring Diagram (Prior to November 1985)</b>	Ref.	
	4931346	<b>Engine Wiring Diagram - Ford (Prior to June 1985)</b>	Ref.	D
	4920425	Harness, Engine	1	
	4931435/ 1280529	<b>Engine Wiring Diagram - Ford (June 1985 to November 1985)</b>	Ref.	-/B
	4920529	Harness, Engine	1	
	4931403	<b>Ground Control Box Wiring Diagram (Prior to June 1985) (See Ground Control Box for Harnesses)</b>	Ref.	A
	4931458	<b>Ground Control Box Wiring Diagram (June 1985 to November 1985) (See Ground Control Box for Harnesses)</b>	Ref.	B
	4931360	<b>Valve Wiring Diagram - 3 Stack</b>	Ref.	-
	4931361	<b>Valve Wiring Diagram - 3 Stack (Ford)</b>	Ref.	-
	4931406/ 1280500	<b>Valve Wiring Diagram - 4 Stack/Single Speed (See Ground Control Box for Harnesses)</b>	Ref.	-/-
	4931407/ 1280500	<b>Valve Wiring Diagram - 4 Stack/2 Speed (See Ground Control Box for Harnesses)</b>	Ref.	-/-
		<b>Wiring Diagrams (November 1985 to Mid 1987)</b>		
		<b>Wiring Diagram - Deutz</b>	Ref.	
	4931499/ 1280584	<b>Engine Wiring Diagram With 3 Stack Racine Prop Valve</b>	Ref.	A/A
	4931485/ 1280591	<b>Engine Wiring Diagram With 4 Stack Racine Prop Valve</b>	Ref.	A/C
	4920581	Harness, Engine	1	
	4931497/ 1280584	<b>Engine Wiring Diagram With Glow Plug</b>	Ref.	A/A
	4931476	<b>Ground Control Box Wiring Diagram (See Ground Control Box for Harnesses)</b>	Ref.	E
	4931487/ 1280584	<b>Valve Wiring Diagram - Without Steering Wheel</b>	Ref.	A/A
	4931488/ 1280584	<b>Valve Wiring Diagram - With Steering Wheel</b>	Ref.	B/A
		<b>Wiring Diagram - Ford Without Prop Tele</b>	Ref.	
	4931528/1280601	<b>Engine Wiring Diagram</b>	Ref.	-/A
	4920601	Harness, Engine	1	
	4931476	<b>Ground Control Box Wiring Diagram (See Ground Control Box for Harnesses)</b>	Ref.	E
	4931487/ 1280601	<b>Valve Wiring Diagram - Without Steering Wheel</b>	Ref.	A/A

# SECTION 7 ELECTRICAL

FIG & ITEM #	PART NUMBER	DESCRIPTION	QTY.	REV.
	4931488/ 1280601	Valve Wiring Diagram - With Steering Wheel	Ref.	-/A
		Wiring Diagram - Ford With Prop Tele	Ref.	
	4931528/ 1280602	Engine Wiring Diagram	Ref.	-/B
	4920601	Harness, Engine	1	
	4931476	Ground Control Box Wiring Diagram (See Ground Control Box for Harnesses)	Ref.	E
	4931489/ 1280602	Valve Wiring Diagram - Without Steering Wheel	Ref.	-/B
	4931490/ 1280602	Valve Wiring Diagram - With Steering Wheel	Ref.	-/B
		Wiring Diagram - Wisconsin Without Prop Tele	Ref.	
	4931440/1280577	Engine Wiring Diagram	Ref.	C/C
	4931476	Ground Control Box Wiring Diagram (See Ground Control Box for Harnesses)	Ref.	E
	4931487/1280577	Valve Wiring Diagram - Without Steering Wheel	Ref.	A/C
	4931488/1280577	Valve Wiring Diagram - With Steering Wheel	Ref.	-/C
		Wiring Diagram - Wisconsin With Prop Tele	Ref.	
	4931440/1280578	Engine Wiring Diagram	Ref.	C/-
	4931476	Ground Control Box Wiring Diagram (See Ground Control Box for Harnesses)	Ref.	E
	4931489/1280578	Valve Wiring Diagram - Without Steering Wheel	Ref.	—/—
	4931490/1280578	Valve Wiring Diagram - With Steering Wheel	Ref.	—/—
		<b>Standard Wiring Diagrams (Vickers Prop Valve Machines)</b>	Ref.	
		<b>Wiring Diagrams - Standard Controls</b>		
		<b>Wiring Diagrams - Deutz and Wisconsin:</b>		
	4931623/1280727*	Engine Wiring Diagram - Deutz	Ref.	H/K
	4920852	Harness, Engine	1	
	4921762	Harness, Fuseable Link	1	
	4360212	Breaker, Circuit - 3 Amp	1	
	3990010	Diode - 6 Amp	1	
	4931622/ 1280727	Engine Wiring Diagram - Wisconsin (Prior to July 1988)	Ref.	E/K
	4360212	Breaker, Circuit - 3 Amp	1	
	3990010	Diode - 6 Amp	1	
	4931622/1280750	Engine Wiring Diagram - Wisconsin (Prior to July 1988)	Ref.	E/J
	4931622/1280727	Engine Wiring Diagram - Wisconsin (Prior to July 1988) (80H)	Ref.	E/K
	4920850	Harness, Engine	1	
	4931826/1280750*	Engine Wiring Diagram - Wisconsin (July 1988 to Present)	Ref.	D/J
	4921128	Harness, Engine	1	
	3990010	Diode - 6 Amp	1	

# SECTION 7 ELECTRICAL

FIG & ITEM #	PART NUMBER	DESCRIPTION	QTY.	REV.
	4931626	<b>Ground Control Box Wiring Diagram (Prior to May 1994) (See Ground Control Box Installation for Harnesses)</b>	Ref.	G
	4932704	<b>Ground Control Box Wiring Diagram (May 1994 to Present) (See Ground Control Box Installation for Harnesses)</b>	Ref.	6
		<b>Wiring Diagrams - Ford:</b>	Ref.	—
	4931629/1280764	<b>Engine Wiring Diagram - Std (Prior to June 1987)</b>	Ref.	B/B
	4360228	Switch, Remote Speed Set	1	
	4920979	Harness, Engine	1	
	4931685/1280826	<b>Engine Wiring Diagram-Std (June 1987 - February 1995)</b>	Ref.	F/H
	4360228	Switch, Remote Speed Set	1	
	4920997	Harness, Engine (June 1987 to March 1991)	1	
	4921309	Harness, Engine (March 1991 to Feb 1995)	1	
	4932745/1282353*	<b>Engine Wiring Diagram - Std (Feb 1995 - May 1995)</b>	Ref.	-/B
	4921716	Harness, Engine	1	
	4932811/1282459*	<b>Engine Wiring Diagram - Std (May 1995 - Present)</b>	Ref.	B/B
	4921761	Harness, Engine	1	
	4931687/1281189	<b>Engine Wiring Diagram - UL dual Fuel (Prior to February 1995)</b>	Ref.	A/C
	4920997	Harness, Engine (June 1987 to March 1991)	1	
	4921309	Harness, Engine (March 1991 to Feb 1995)	1	
	4360228	Switch, Remote Speed Set	1	
	4932768	<b>Engine Wiring Diagram - UL Dual Fuel (Feb 1995 to Present)</b>	Ref.	A/C
	3990010	Diode 6 Amp	3	
	4360228	Switch, Remote Speed Set	1	
	2400026	Fuse 5 Amp	1	
	4931738/1281129	<b>Engine Wiring Diagram - UL LP Gas Only With Battery Disconnect</b>	Ref.	B/C
	4360228	Switch, Remote Speed Set	1	
	2400008	Fuse 3/4 Amp	1	
	2400006	Fuse 5 Amp	1	
	3990010	Diode - 6 Amp	6	
	4931996/1281189	<b>Engine Wiring Diagram - UL LP Gas Only With P.G. Electronics</b>	Ref.	A/C
	4360228	Switch, Remote Speed Set	1	
	4920997	Harness, Engine (July 1989 to March 1991)	1	
	4921309	Harness, Engine (March 1991 to Present)	1	
	1060330	Cable, Electrical - 16/3	23 Ft.	
	1060331	Cable, Electrical - 16/4	38 Ft.	
	4931620	<b>Ground Control Wiring Diagram (Prior to May 1994) (See Ground Control Box Installation for Harnesses)</b>	Ref.	G
	4932704	<b>Ground Control Wiring Diagram (May 1994 to Present) (See Ground Control box Installation for Harnesses)</b>	Ref.	6
		<b>Wiring Diagrams - Hydraulic Controls</b>		

# SECTION 7 ELECTRICAL

**SECTION 7 ELECTRICAL**

FIG & ITEM #	PART NUMBER	DESCRIPTION	QTY.	REV.
		<b>Wiring Diagrams - Deutz and Wisconsin:</b>	Ref.	
	4931623/1280992*	<b>Engine Wiring Diagram - Deutz</b>	Ref.	G/E
	4920852	Harness, Engine	1	
	4360212	Breaker, Circuit - 3 Amp	1	
	3990010	Diode - 6 Amp	1	
	4931622/1280992	<b>Engine Wiring Diagram - Wisconsin (Prior to July 1988)</b>	Ref.	E/E
	4920850	Harness, Engine	1	
	4931826/1280992*	<b>Engine Wiring Diagram - Wisconsin (July 1988 to Present)</b>	Ref.	D/E
	4921128	Harness, Engine	1	
	4931836	<b>Ground Control Box Wiring Diagram (80H) (See Ground Control Box Installation for Harnesses)</b>	Ref.	B
	4931685/1280991	<b>Engine Wiring Diagram (June 1987 to March 1995)</b>	Ref.	E/D
	4360228	Switch, Remote Speed Set	1	
	4920997	Harness, Engine (June 1987 to March 1991)	1	
	4921309	Harness, Engine (March 1991 to Present)	1	
	4931836	<b>Ground Control Box Wiring Diagram (See Ground Control Box Installation for Harnesses)</b>	Ref.	B
	4932439	<b>Valjar Machines Wiring Diagram</b>	Ref.	A
	4931349	<b>WCBC Machines Wiring Diagram</b>	Ref.	-



# SECTION 7 ELECTRICAL

FIGURE 7-2. WIRING DIAGRAM - DUAL FUEL

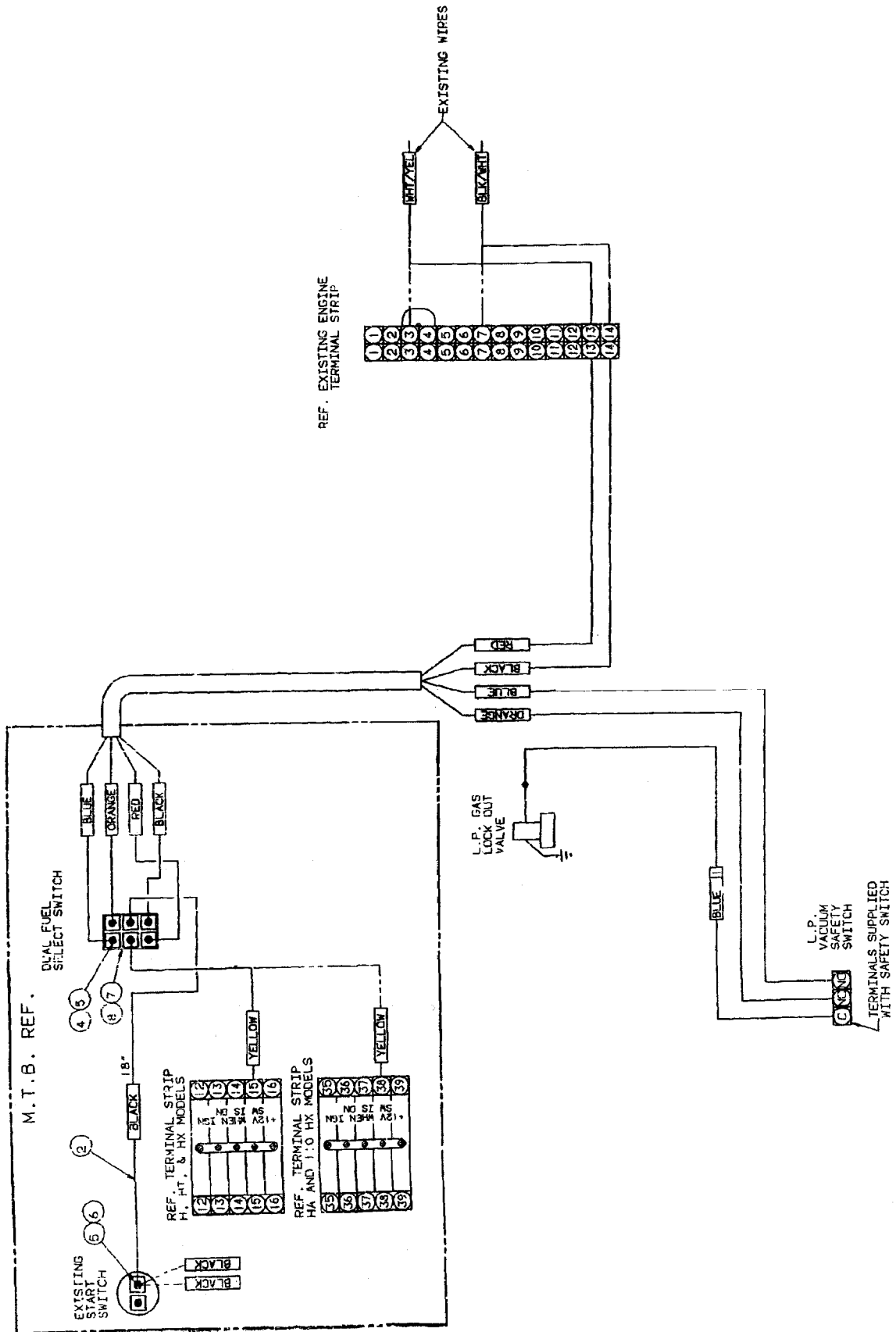

# SECTION 7 ELECTRICAL

FIGURE 7-3. WIRING DIAGRAM - GENERATOR (DEUTZ ENGINES)

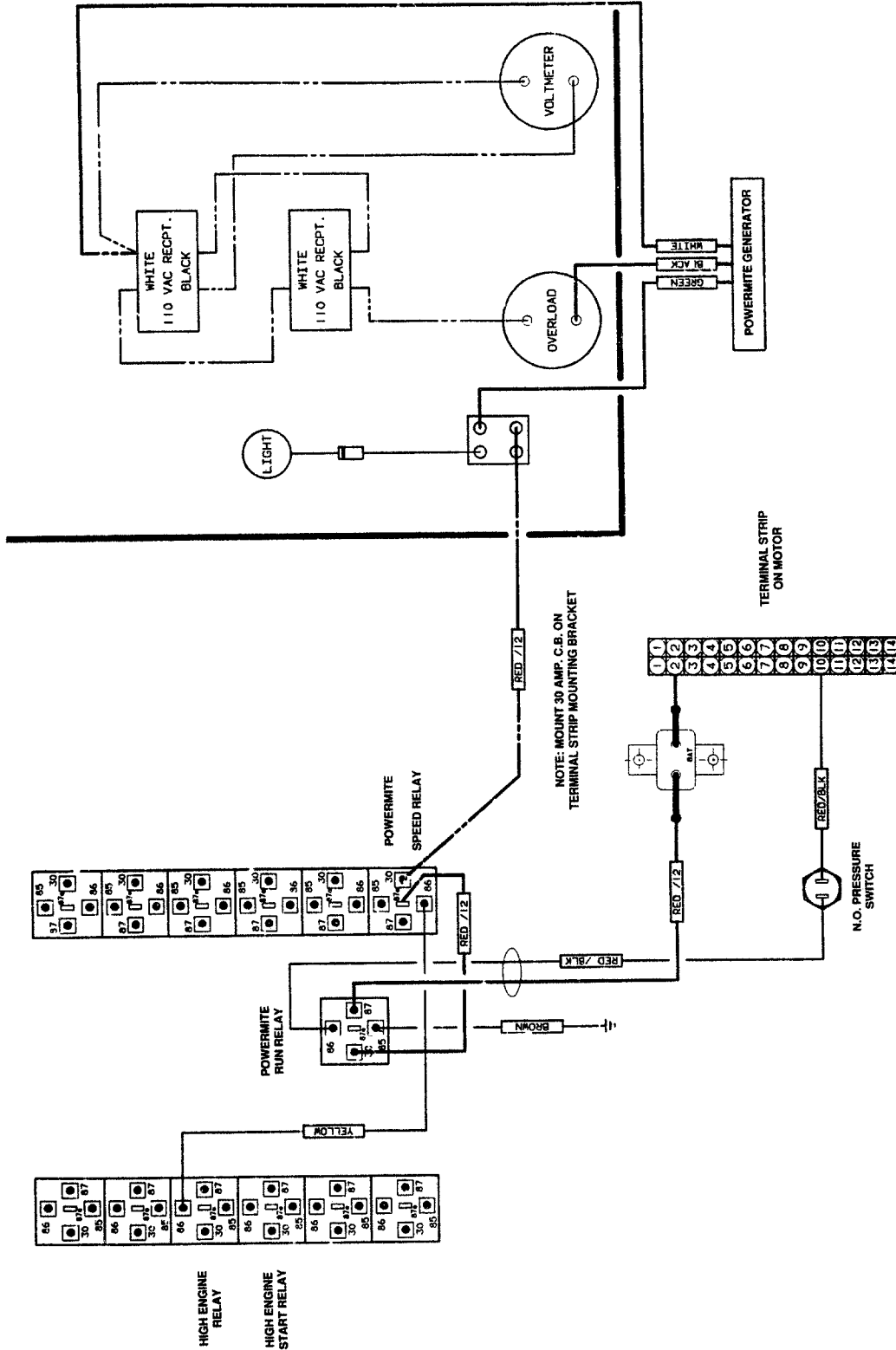

4931693 E



# SECTION 7 ELECTRICAL

FIGURE 7-5. WIRING DIAGRAM - PLATFORM CONSOLE STANDARD CONTROLS (SHEET 1 OF 2)

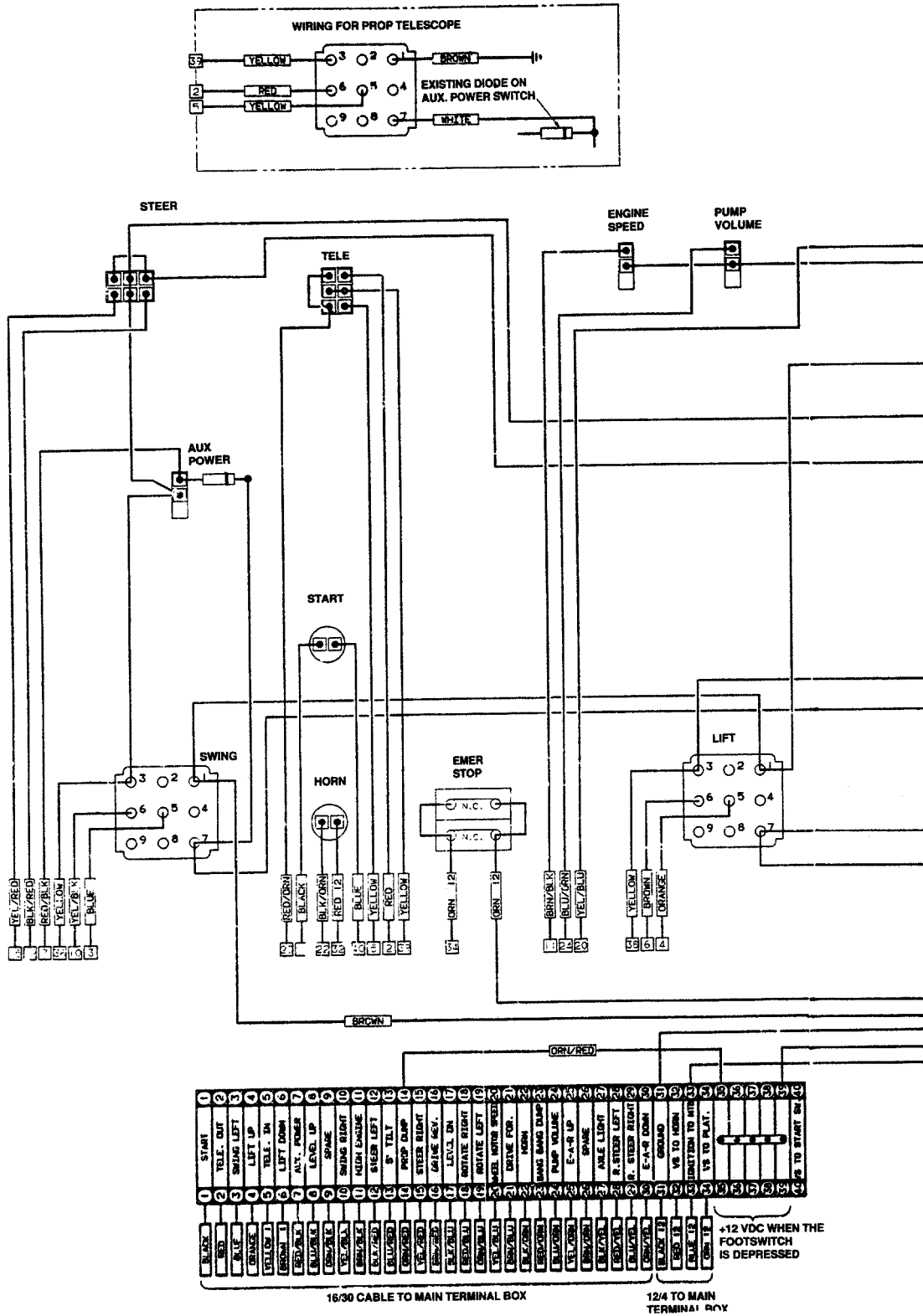

SECTION 7 ELECTRICAL

# SECTION 7 ELECTRICAL

FIGURE 7-5. WIRING DIAGRAM - PLATFORM CONSOLE STANDARD CONTROLS (SHEET 2 OF 2).

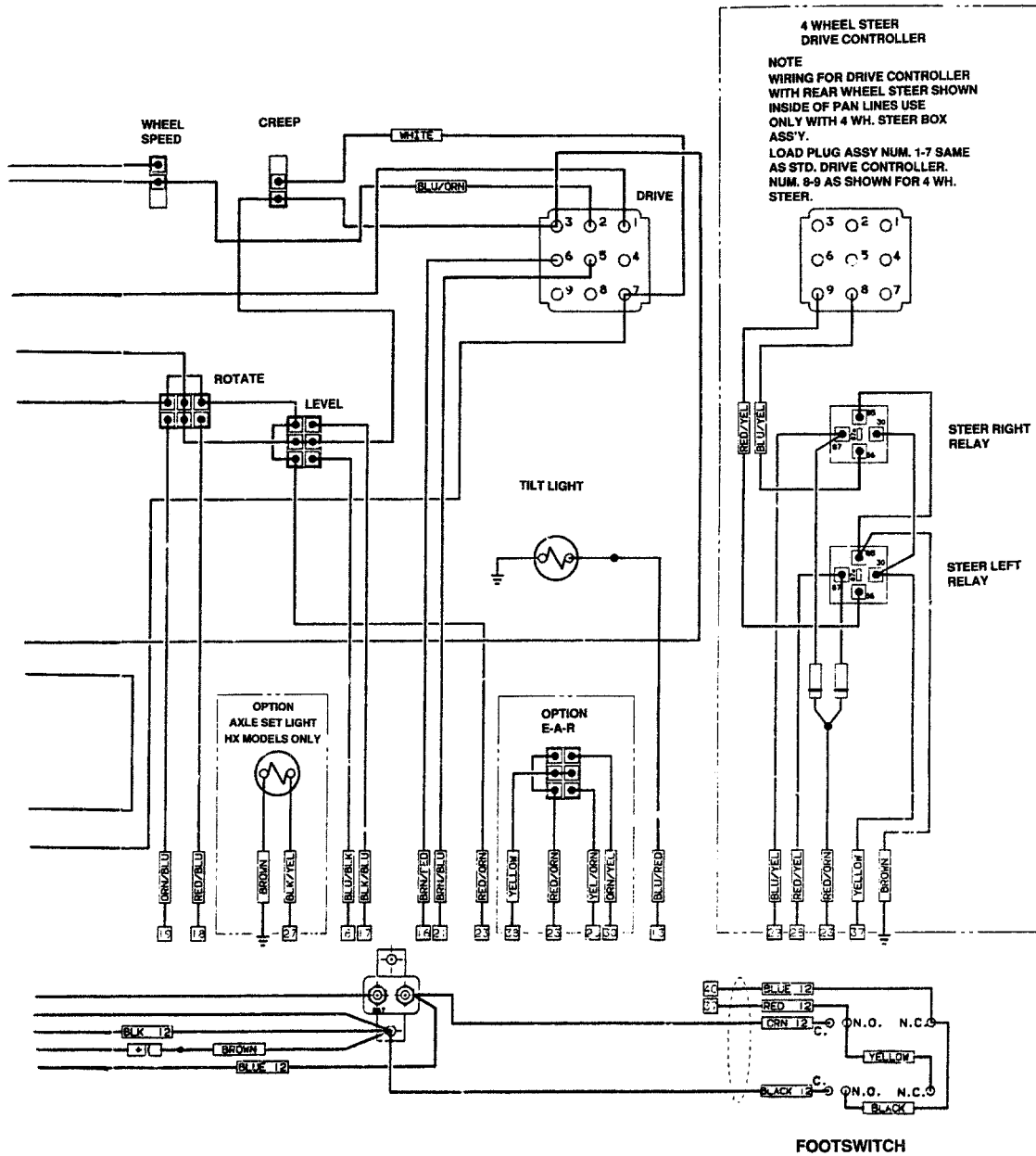

1281682 —

# SECTION 7 ELECTRICAL

**S  
E  
C  
T  
I  
O  
N  
  
7  
  
E  
L  
E  
C  
T  
R  
I  
C  
A  
L**

**THIS PAGE INTENTIONALLY LEFT BLANK**

# SECTION 7 ELECTRICAL

FIGURE 7-6. WIRING DIAGRAM - PLATFORM CONSOLE HYDRAULIC CONTROLS

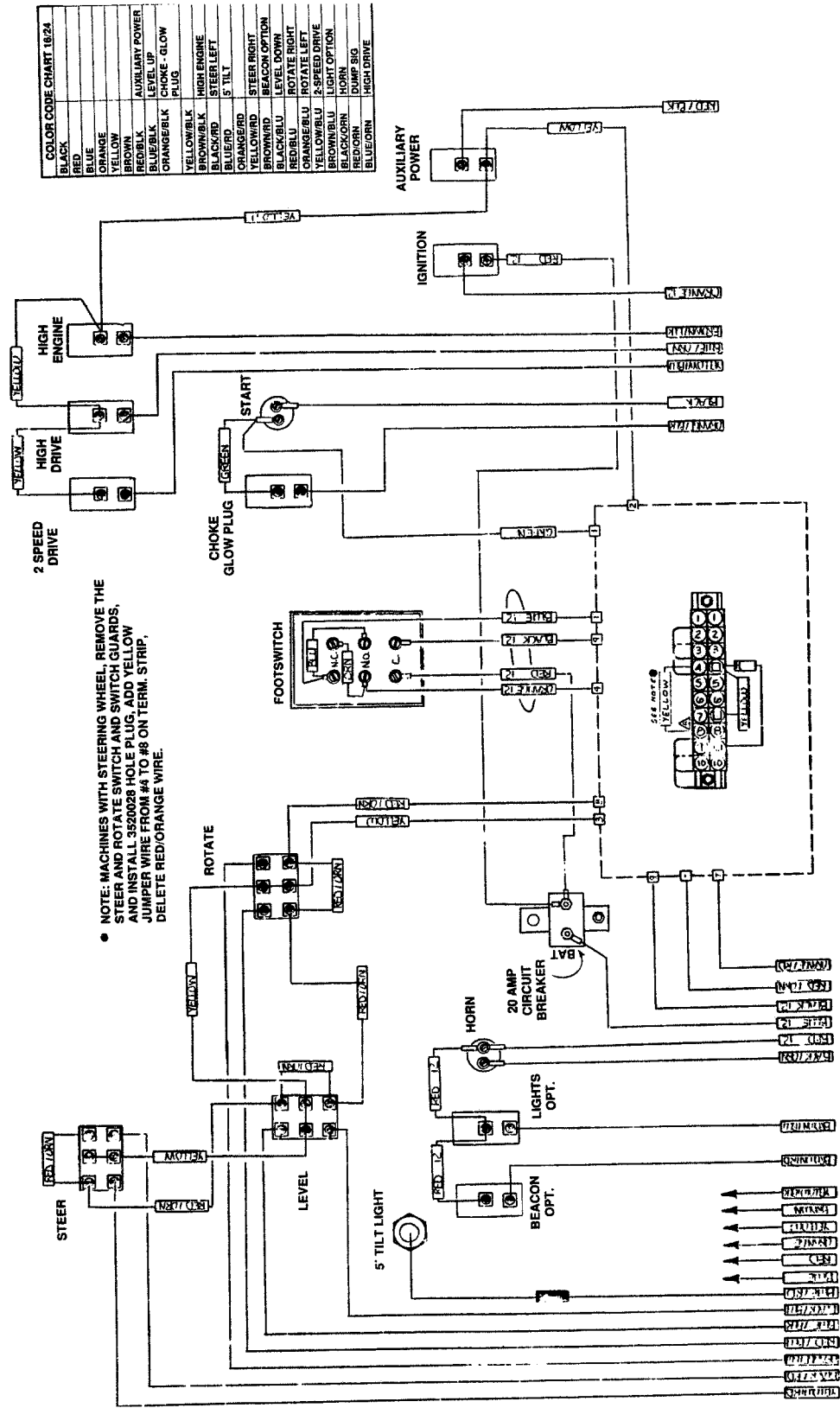

COLOR CODE CHART 18/24	
BLACK	
BRED	
BLUE	
ORANGE	
YELLOW	AUXILIARY POWER
BROWN	LEVEL UP
BLUE/BLK	CHOKE - GLOW PLUG
CHARGE/BLK	HIGH ENGINE
YELLOW/BLK	STEER LEFT
BROWN/BLK	5' TILT
BLACK/RD	STEER RIGHT
BLUE/RD	BEACON OPTION
BROWN/RD	ROTATE DOWN
RED/BLU	ROTATE RIGHT
RED/BLU	ROTATE LEFT
YELLOW/BLU	2-SPEED DRIVE
BROWN/BLU	LIGHT OPTION
BLACK/ORN	HORN
RED/ORN	DUMP SIG
BLUE/ORN	HIGH DRIVE

1280994 D

# SECTION 7 ELECTRICAL

FIGURE 7-7. WIRING DIAGRAM - STANDARD (DEUTZ ENGINE/FIXED AXLE/ STANDARD CONTROLS) (SHEET 1 OF 2)

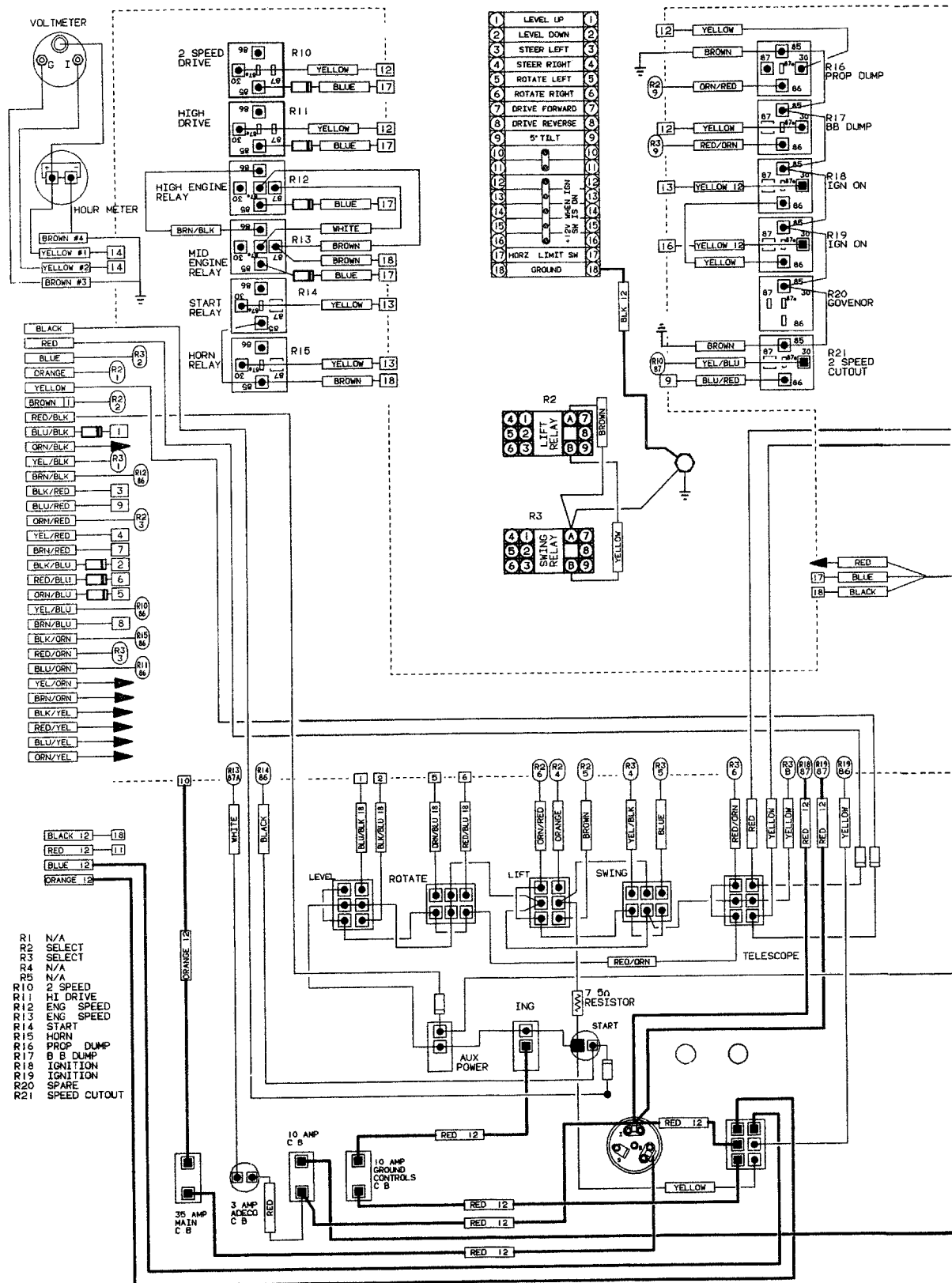



# SECTION 7 ELECTRICAL

FIGURE 7-7. WIRING DIAGRAM - STANDARD (DEUTZ ENGINE/FIXED AXLE/ STANDARD CONTROLS) (SHEET 2 OF 2)

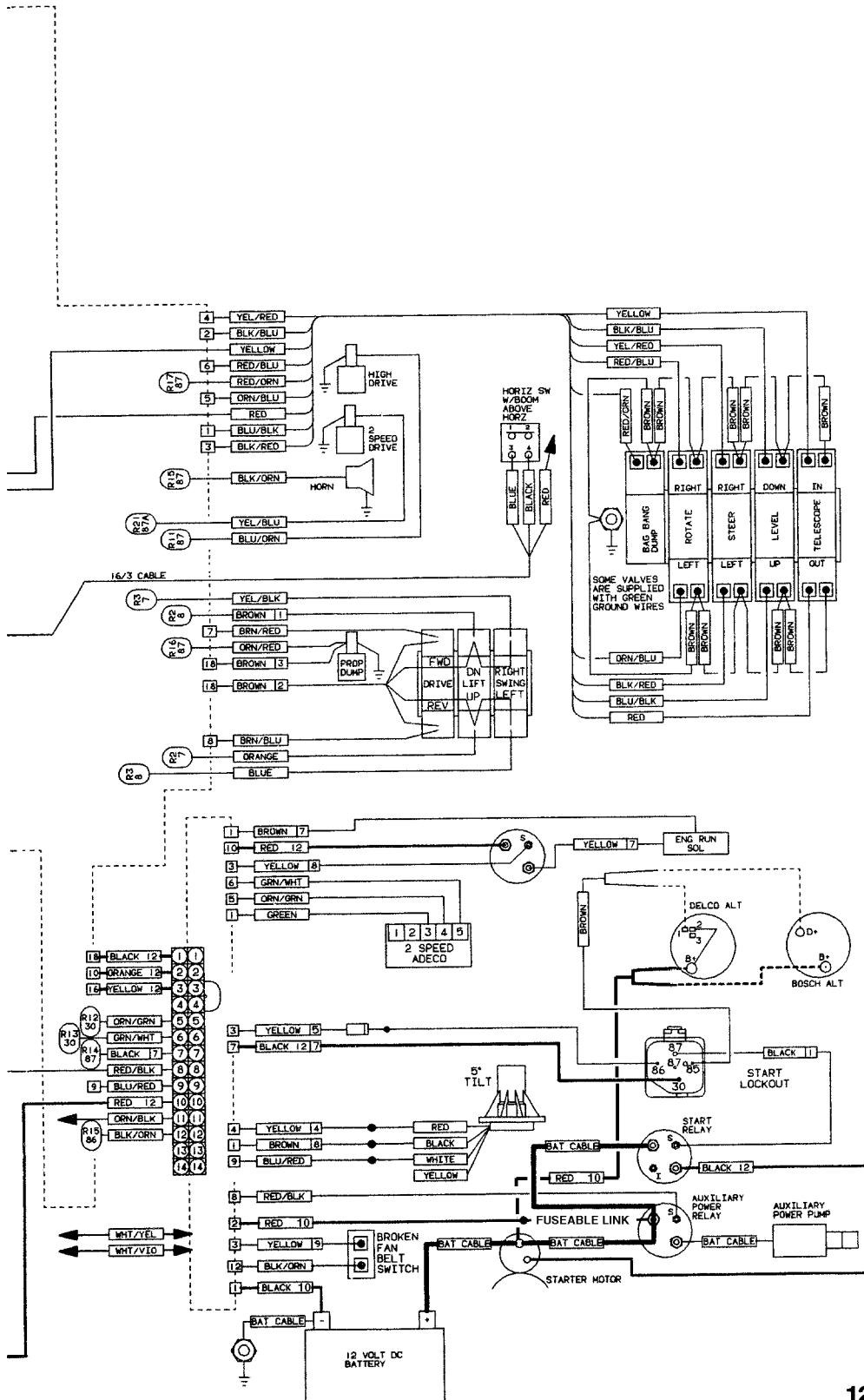

1280727 K

# SECTION 7 ELECTRICAL

FIGURE 7-8. WIRING DIAGRAM - STANDARD (DEUTZ ENGINE/OSCILLATING AXLE/STANDARD CONTROLS) (SHEET 1 OF 2)

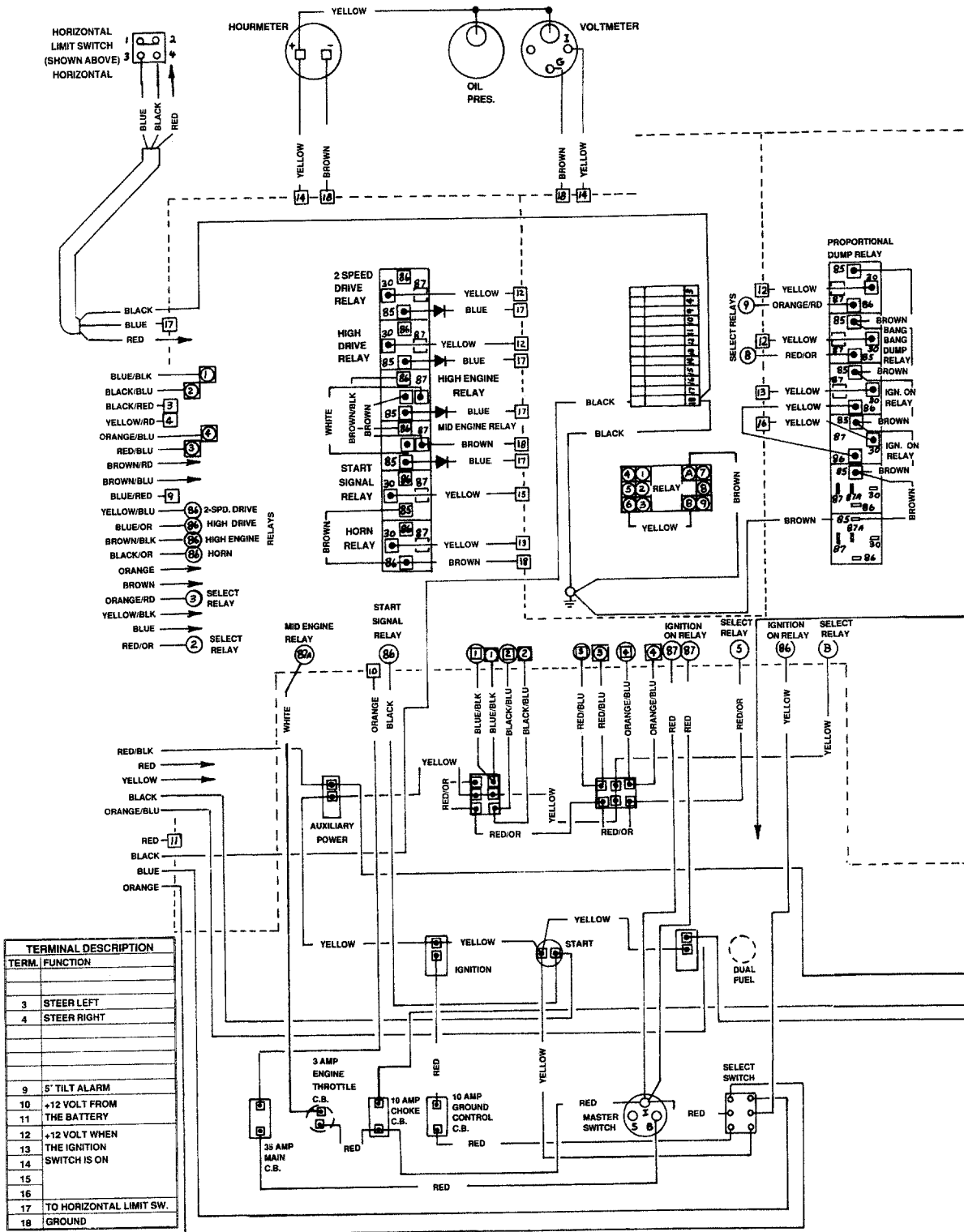

1280992 E

# SECTION 7 ELECTRICAL

FIGURE 7-8. WIRING DIAGRAM - STANDARD (DEUTZ ENGINE/OSCILLATING AXLE/STANDARD CONTROLS) (SHEET 2 OF 2).

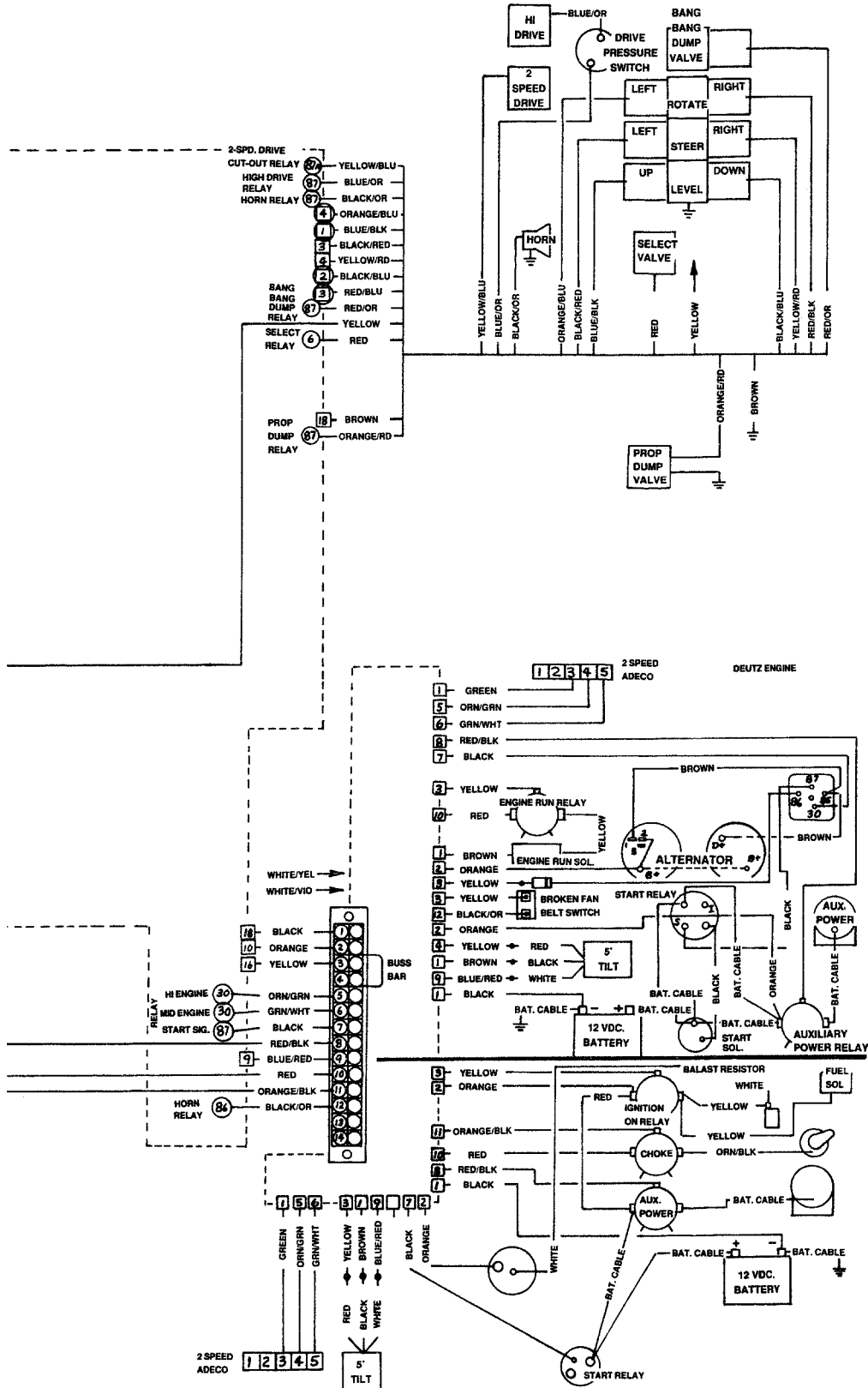

# SECTION 7 ELECTRICAL

FIGURE 7-9. WIRING DIAGRAM - STANDARD (DEUTZ ENGINE/HYDRAULIC CONTROLS) (SHEET 1 OF 2)

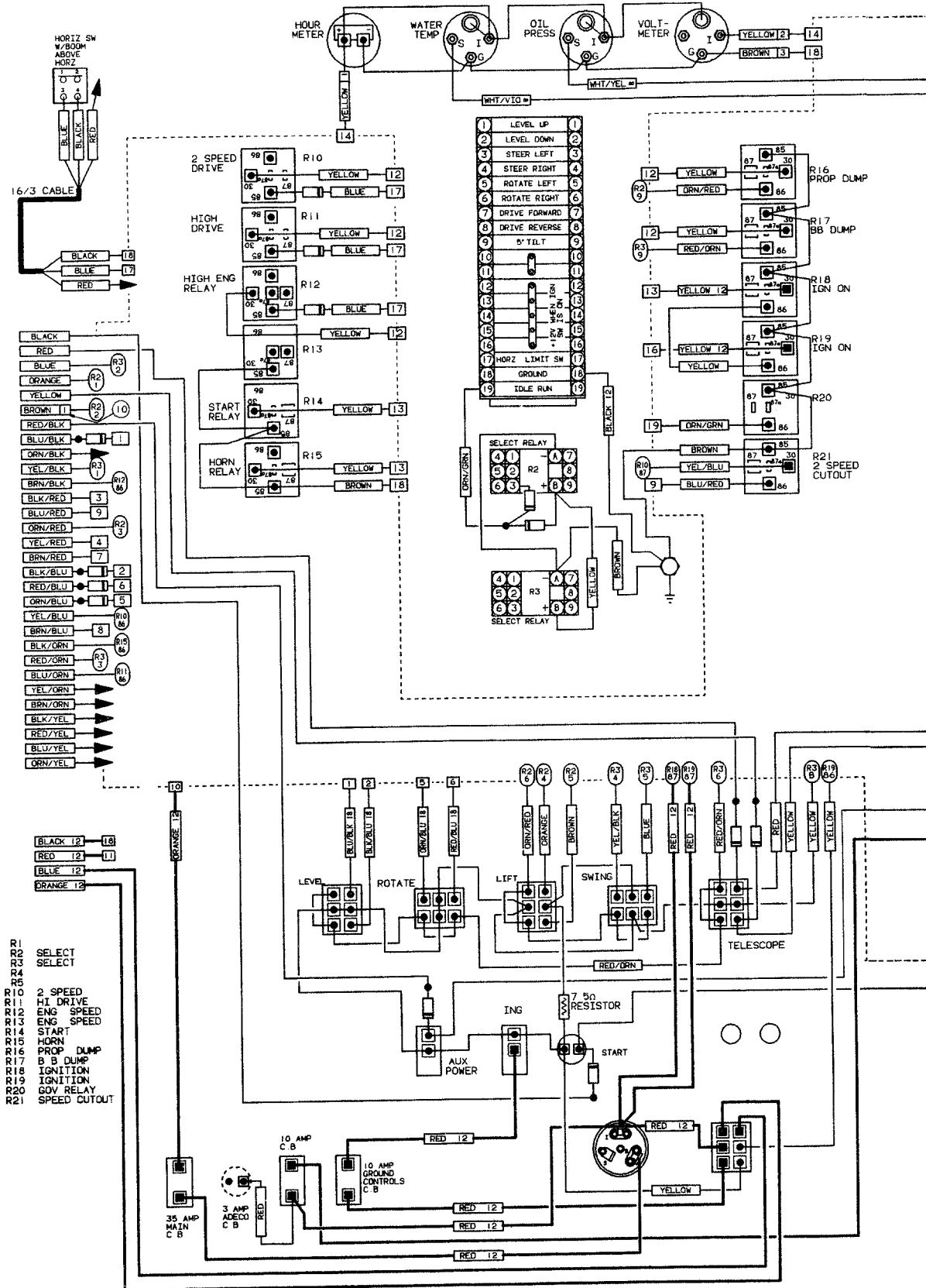

- R1 SELECT
- R2 SELECT
- R3 SELECT
- R4
- R5
- R10 2 SPEED
- R11 HI DRIVE
- R12 ENG SPEED
- R13 ENG SPEED
- R14 START
- R15 HORN
- R16 PROP DUMP
- R17 B B DUMP
- R18 IGNITION
- R19 IGNITION
- R20 GOV RELAY
- R21 SPEED CUTOUT

# SECTION 7 ELECTRICAL

FIGURE 7-9. WIRING DIAGRAM - STANDARD (DEUTZ ENGINE/HYDRAULIC CONTROLS) (SHEET 2 OF 2)

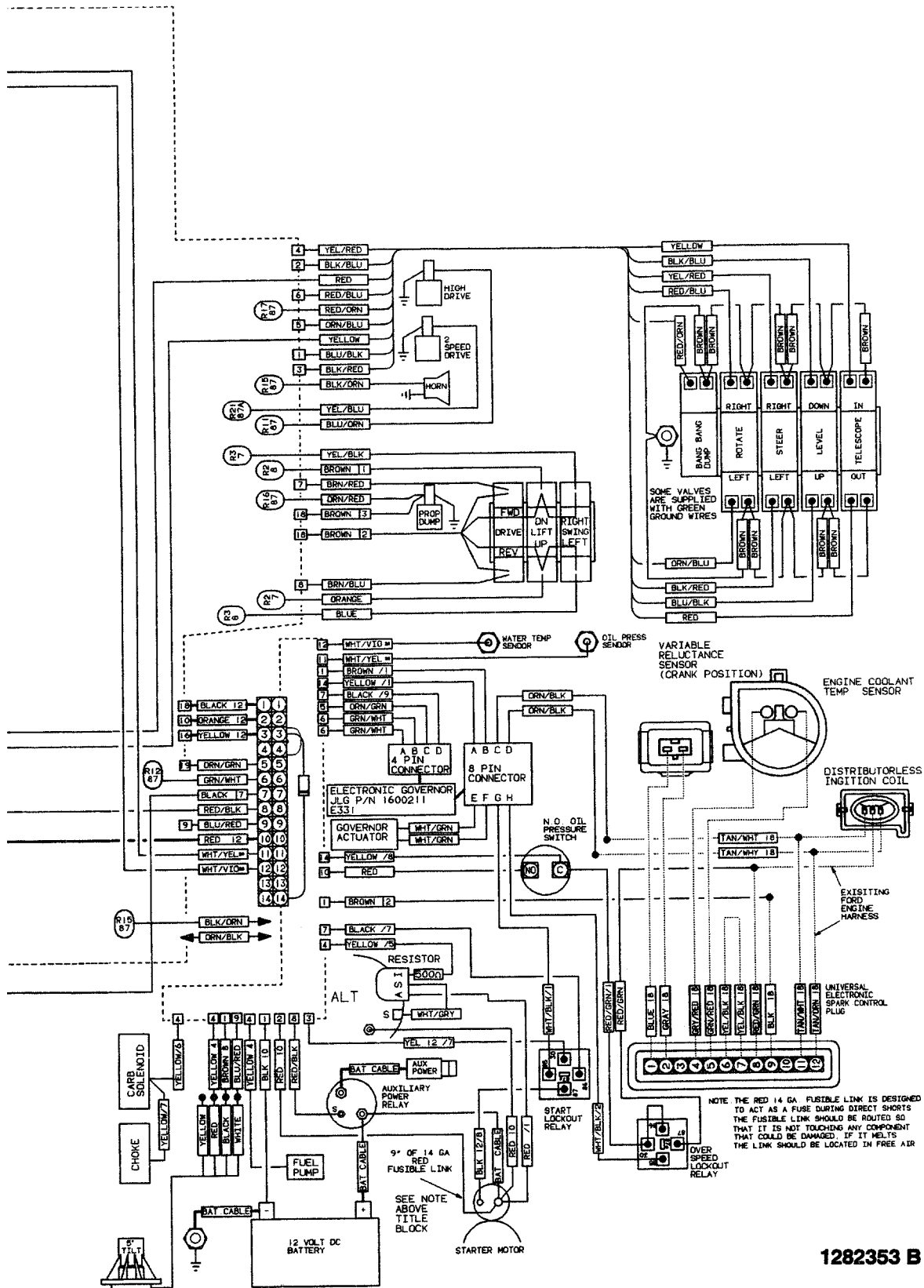

1282353 B

SECTION 7 ELECTRICAL

# SECTION 7 ELECTRICAL

FIGURE 7-10. WIRING DIAGRAM - STANDARD (FORD ENGINE WITH HYDRAULIC CONTROLS) (SHEET 1 OF 2)

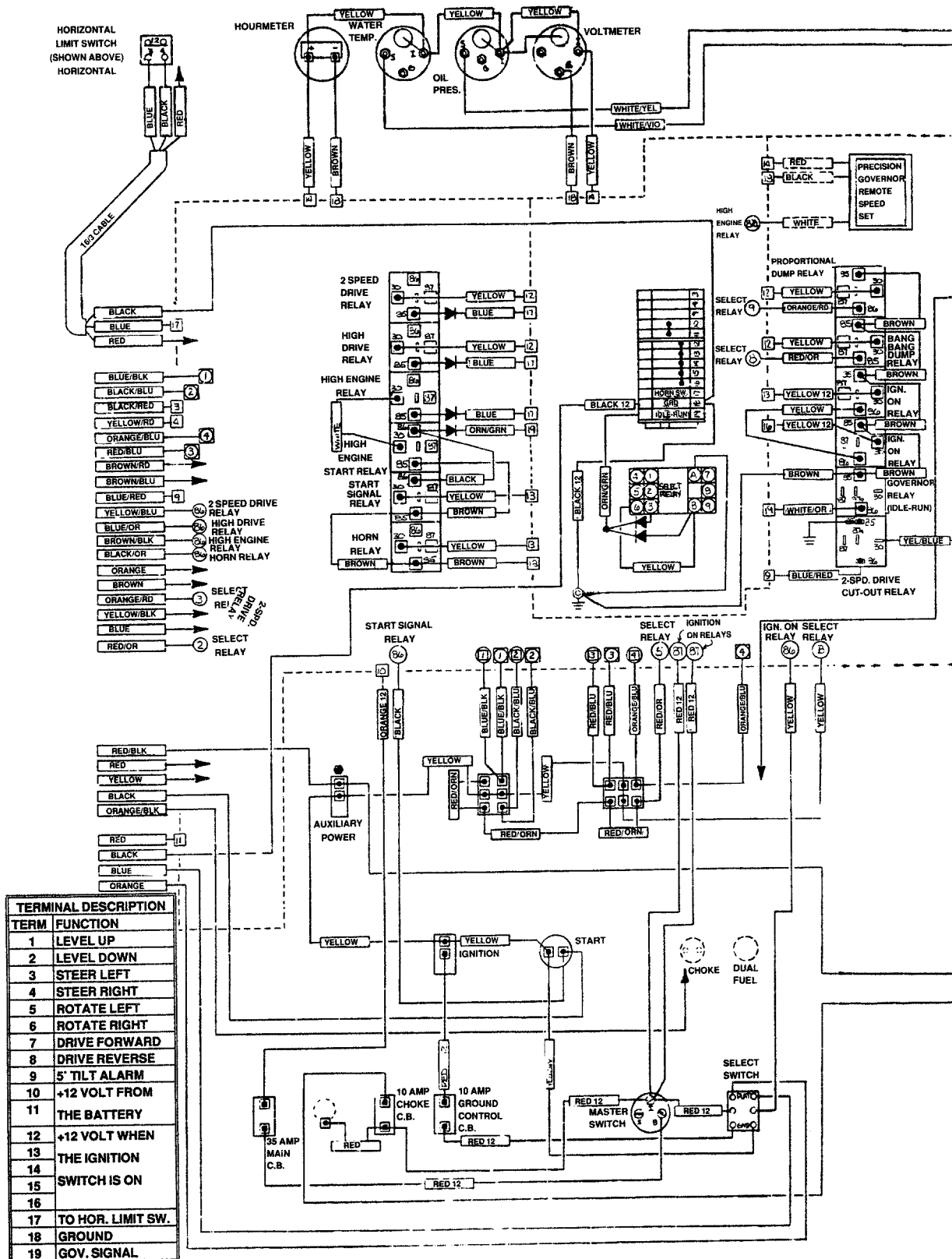

# SECTION 7 ELECTRICAL

FIGURE 7-10. WIRING DIAGRAM - STANDARD (FORD ENGINE WITH HYDRAULIC CONTROLS) (SHEET 2 OF 2)

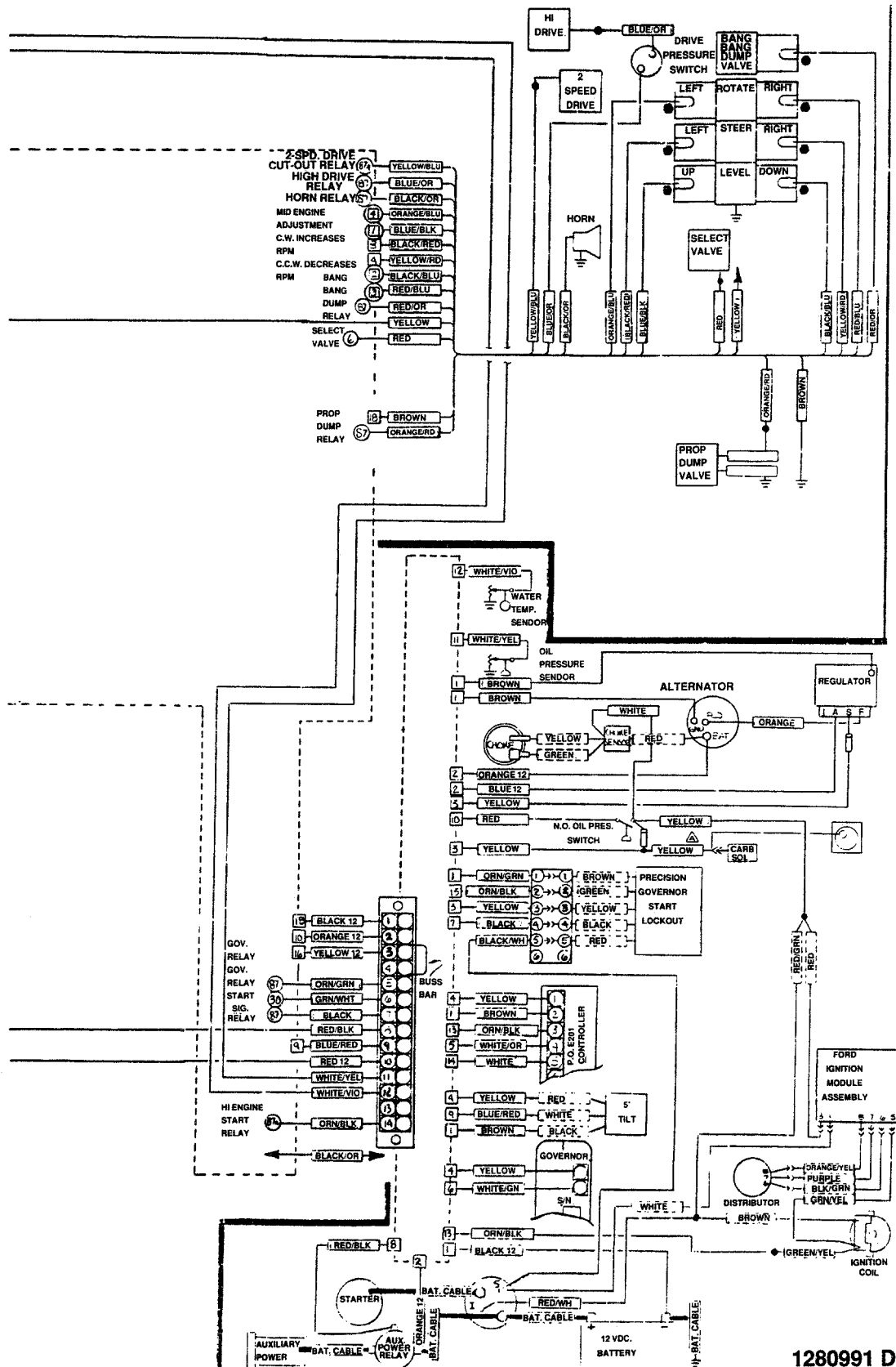

1280991 D

# SECTION 7 ELECTRICAL

**S  
E  
C  
T  
I  
O  
N  
  
7  
  
E  
L  
E  
C  
T  
R  
I  
C  
A  
L**

THIS PAGE INTENTIONALLY LEFT BLANK



# SECTION 8 DECALS

TABLE OF CONTENTS		
FIGURE	DESCRIPTION	PAGE
8-1	DECALS INSTALLATION - DOMESTIC (BROWN) .....	8-2
8-2	DECALS INSTALLATION - DOMESTIC (BLACK) .....	8-8
8-3	DECALS INSTALLATION - LATIN AMERICA.....	8-12



# SECTION 8 DECALS

**FIGURE 8-1. DECALS INSTALLATION - DOMESTIC (BROWN)**

FIG & ITEM #	PART NUMBER	DESCRIPTION	QTY.	REV.
		<b>DECALS INSTALLATION - DOMESTIC</b>	Ref.	
	0236356	<b>DECALS INSTALLATION - 60H WITH BROWN DECALS AND STANDARD CONTROLS</b>	Ref.	18
	9983546	<b>DECALS INSTALLATION - 60H WITH BROWN DECALS AND HYDRUALIC CONTROLS</b>	Ref.	B
	0238172	<b>DECALS INSTALLATION - 60H+6 WITH STANDARD CONTROLS</b>	Ref.	13
	9983547	<b>DECALS INSTALLATION - 60H+6 WITH HYDRAULIC CONTROLS</b>	Ref.	C
	0237150	<b>DECALS INSTALLATION - 70H WITH STANDARD CONTROLS</b>	Ref.	15
	9983549	<b>DECALS INSTALLATION - 70H WITH HYDRAULIC CONTROLS</b>	Ref.	B
1	Not Available	Nameplate - Serial Number	1	
2	1700584	Decal - Patent	1	
3		Decal - Manual Options:	1	
	3251569	Decal (Located on Engine Side - Used Prior to July 1987)	1	
	1700157	Decal (Mounted on Manual Storage Box at Rear - July 1987 to May 1994)		
	1701509	Decal (Mounted on Manual Storage Box at Rear - May 1994 to Present)		
4		Decal - Ground Control Options:	1	
	1700582	Decal (Prior to May 1994)		
	1702293	Decal (May 1994 to Present)		
5		Decal - Caution Options:	1	
	1700643	Decal (Prior to May 1994)		
	1702299	Decal (May 1994 to Present)		
6		Nameplate - Load/Reach Options:	1	
		60H (Standard Controls/Hydraulic Controls)		
	3251587	Nameplate (Standard)		
	3251652	Nameplate (CSA/2:1 Stability)		
	3251758	60H+6 (Standard Controls/Hydraulic Controls)		
		Nameplate - Load/Reach		
	3251657	70H (Standard Controls/Hydraulic Controls)		
7		Decal - Attach Belt Options:	2	
	1700477	Decal (Prior to May 1994)		
	1702276	Decal (May 1994 to July 1995)		
	1702612	September 1995 to S/N 61083		
	1704277	S/N 61083 to Present		
8 to 9	Not Used			
10		Nameplate - Footswitch Options:	1	
	3250453	Nameplate (Prior to July 1987)		
	3251766	Nameplate (July 1987 to June 1992)		
	Not Required	Nameplate (June 1992 to Present)		
11		Decal - No Hands Options:	2	
	1700476	Decal (Prior to May 1994)		
	1702294	Decal (May 1994 to Present)		

## SECTION 8 DECALS

FIGURE 8-1. DECALS INSTALLATION - DOMESTIC (BROWN) (CONTINUED)

FIG & ITEM #	PART NUMBER	DESCRIPTION	QTY.	REV.
12	Not Required	Decal - Extend-A-Reach Options: Model 60H	2	
	1700880	Decal (Prior to September 1990)		
	1701375	Decal (September 1990 to Present)		
	Not Required	Model 70H		
13		Decal - Crushing Options:	4	
	1700585	Decal (Prior to May 1994)		
	1702277	Decal (May 1994 to Present)		
14		Decal - FWD Options:	4	
	1700423	Decal (Brown) (Prior to November 1989)		
	1700977	Decal (Creme) (November 1989 to November 1992)		
	Not Required	Decal (November 1992 to Present)		
15		Decal - Arrow Options:	4	
	1700568	Decal (Brown) (Prior to November 1989)		
	1700978	Decal (Creme) (November 1989 to November 1992)		
	1701529	Decal (Black/White) (November 1992 to Present)		
16	Not Used			
17	1700419	Decal - Hydraulic (Brown)	1	
18		Decal - Tie-Down Options:	4	
	1700575	Decal (Brown) (Prior to November 1989)		
	1700976	Decal (Creme) (November 1992 to S/N 45895)		
	1702300	Decal (S/N 45895 to Present)		
19		Decal - Logo Options:	A/R	
	1700427	Decal (Prior to November 1989)	2	
	Not Required	Decal (November 1989 to Present)	0	
20	1700431	Decal - Brown/Orange Stripe	40 Ft.	
21		Decal - Crushing Options:	2	
	1700640	Decal (Prior to May 1994)		
	1702284	Decal (May 1994 to Present)		
22	3820001	Rivet	A/R	
23 to 24	Not Used			
25		Decal - Electrocution Hazard	3	
	1700580	Decal (Prior to May 1994)		
	1702292	Decal (May 1994 to Present)		
26		Decal - Lift Here Options:	2	
	1700377	Decal - Lift Here (Brown) (Prior to S/N 45895)		
	1701500	Decal - Lift Here (S/N 45895 to Present)		
27		Decal - Model Designation Options (Brown):	2	
	1700576	Decal - Model 60H (Prior to March 1992)		
	1701752	Decal - Model 60H (March 1992 to Present)		
	1700889	Decal - Model 66H (Prior to September 1990)		
	1701378	Decal - Model 60H+6 (September 1990 to Present)		
	1700675	Decal - Model 70H (Prior to March 1992)		
	1701751	Decal - Model 70H (March 1992 to Present)		
28		Decal - JLG Lift Options:	3	
	1700422	Decal (Brown) (Prior to March 1992)		
	1701684	Decal (Brown) (March 1992 to Present)		

# SECTION 8 DECALS

**FIGURE 8-1. DECALS INSTALLATION - DOMESTIC (BROWN) (CONTINUED)**

FIG & ITEM #	PART NUMBER	DESCRIPTION	QTY.	REV.
29	1700583	Decal - Ground Control Location	1	
30		Decal - Inspection Options:	1	
	1700593	Decal (Prior to May 1994)	1	
	1702153	Decal (May 1994 to Present)	1	
31	Not Used			
32	3251243	Nameplate - 120V	1	
33	0961127	Bushing, Snap	1	
34	0100010	Loctite, Adhesive (Not Shown)	A/R	
35		Decal Options:	1	
	1700756	Decal - Full/Add (Brown) (Prior to S/N 59048)		
	1701503	Low Oil Level (S/N 59048 to Present)		
	1701502	High Oil Level (S/N 59048 to Present)		
36	Not Used			
37	0860520	Box, Manual Storage (Used July 1987 to Present)	1	
38	3311405	Locknut 1/4"-20NC	5	
39	4751400	Flatwasher 1/4"	6	
40	1060279	Cable, Lanyard	1	
41	0641408	Bolt 1/4"-20NC x 1"	1	
42		Decal Options:	1	
	1700427	Decal - Logo (Prior to November 1989)		
	3251813	Decal - USA (November 1989 to Present)		
43		Decal Options:	1	
	1700422	Decal - JLG Lift (Brown) (Prior to November 1989)		
	1700981	Decal - JLG (Brown) (November 1989 to Present)		
44		Decal - Lift Here Options:	2	
	1700377	Decal (Brown) (Prior to November 1989)		
	1700975	Decal (Creme) (November 1989 to S/N 45895)		
	1701500	Decal (S/N 45895 to Present)		
	1700232	Decal (Black) (Optional)	2	
45		Decal - JLG Options:	1	
	Not Required	Model 60H		
	1701110	Model 60H+6 Options:		
	Not Required	Model 70H		
46		Decal - 500 Lbs. Options:	1	
	Not Required	Model 60H		
	1701678	Model 60H+6 Options:		
	Not Required	Model 70H		
47 to 53	Not Used			
54	1702282	Decal - Warning (Used May 1994 to Present)		
55	Not Used			
56	1702966	Decal - Unrestricted Capacity (S/N 34242 to Present)	2	
		-----		
	2910027	Decal Kit - Brown (60H)	1	
	2900739	Decal Kit - Brown (70H)	1	
		<b>DECALS INSTALLATION (OPTIONAL PARTS)</b>	Ref.	
71		Decal - Fuel LP Gas Options:	1	
	1700429	Prior to May 2000		
	1701543	May 2000 to Present		

## SECTION 8 DECALS

FIGURE 8-1. DECALS INSTALLATION - DOMESTIC (BROWN) (CONTINUED)

FIG & ITEM #	PART NUMBER	DESCRIPTION	QTY.	REV.
72		Decal - Fuel Options:	1	
	1700430	Decal - Gas (Prior to May 2000)		
	1701542	Decal - Gas (May 2000 to Present)		
	1700428	Decal - Diesel (Prior to May 2000)		
	1701505	Decal - Diesel (May 2000 to Present)		
73		Decal - Caution LP Gas Options:	1	
	3251028	Prior to March 1995		
	3252356	March 1995 to Present		
74		Nameplate - Caution Options:	1	
	3251606	Nameplate (2 Speed Machines with Racine Valves)		
	3251548	Nameplate (Single Speed Machines with Racine Valves)		
	3251548	Nameplate (Standard machines with Vickers Valves and PQ Controllers - Built Prior to October 1991)		
	3251607	Nameplate 9CSA/2:1 Stability Machines with Vickers Valves and PQ Controllers - Built Prior to October 1991)		
75	3251549	Nameplate - Danger (Machines Built Prior to October 1991)	1	
76		Nameplate - Caution/Danger Options:	1	
	3252144	Nameplate (Machines with PQ Controllers Built October 1991 to May 1994)		
	3252369	Nameplate (Machines with PQ Controllers Built May 1994 to Present)		
	3251775	Nameplate (Standard Machines with OEM Controllers Built Through		
	3251671	Nameplate (CSA/2:1 Stability Machines with OEM Controllers Built Through October 1991)		
	3252144	Nameplate (Machines with OEM Controllers built October 1991 to May 1994)		
	3252369	Nameplate (Machines with OEM Controllers Built May 1994 to Present)		
77		Mounting Bracket Options:	1	
	3530997	Bracket (Machines Built October 1991 to March 1993)		
	3536671	Bracket (Machines Built March 1993 to Present)		
	0251685	<b>LIFTING DIAGRAM INSTALLATION</b>	Ref.	-
101	3252095	Decal - Lifting Diagram	2	
	3820001	Rivet	8	

# SECTION 8 DECALS

FIGURE 8-1. DECALS INSTALLATION - DOMESTIC (BROWN) (CONTINUED)

FIG & ITEM #	PART NUMBER	DESCRIPTION	QTY.	REV.

# SECTION 8 DECALS

FIGURE 8-2. DECALS INSTALLATION - DOMESTIC (BLACK)

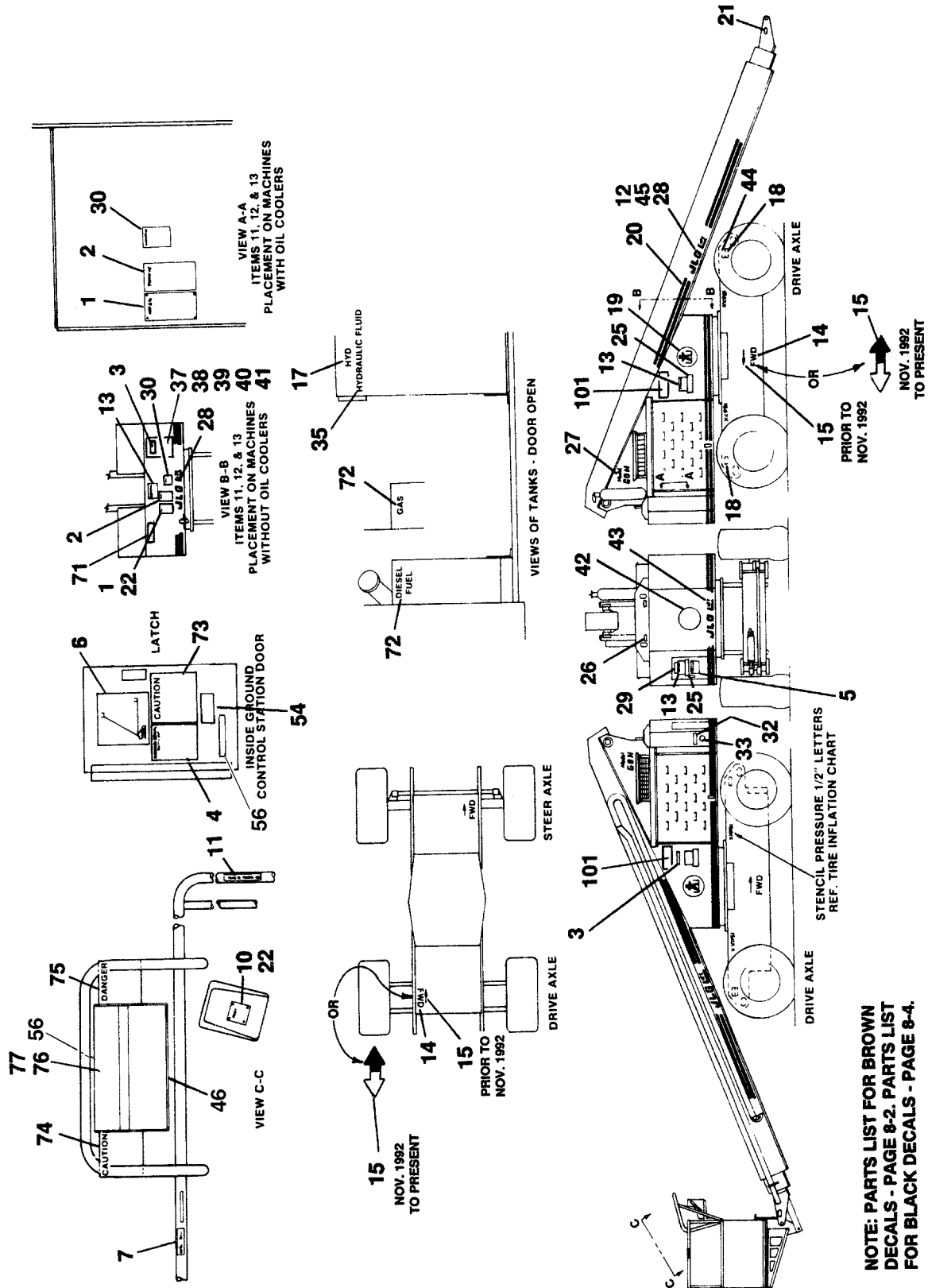



# SECTION 8 DECALS

**FIGURE 8-2. DECALS INSTALLATION - DOMESTIC (BLACK)**

FIG & ITEM #	PART NUMBER	DESCRIPTION	QTY.	REV.
		<b>DECALS INSTALLATION - DOMESTIC</b>	Ref.	
	0239186	<b>DECALS INSTALLATION - 60H WITH BLACK DECALS</b>	Ref.	11
1	Not Available	Nameplate - Serial Number	1	
2	1700584	Decal - Patent	1	
3	3251569	Decal (Located on Engine Side - Used Prior to July 1987)		
	1700157	Decal (Mounted on Manual Storage Box at Rear - July 1987 to May 1994)		
	1701509	Decal (Mounted on Manual Storage Box at Rear - May 1994 to Present)		
4		Decal - Ground Control Options:		
	1700582	Decal (Prior to May 1994)		
	1702293	Decal (May 1994 to Present)		
5		Decal - Caution Options:	1	
	1700643	Decal (Prior to May 1994)		
	1702299	Decal (May 1994 to Present)		
6		Nameplate - Load/Reach Options:	1	
	3251587	Nameplate (Standard)		
	3251652	Nameplate (CSA/2:1 Stability)		
7		Decal - Attach Belt Options:	2	
	1700477	Decal (Prior to May 1994)		
	1702276	Decal (May 1994 to August 1995)		
	1702612	Decal (August 1995 to Present)		
8	Not Used			
9	Not Used			
10		Nameplate - Footswitch Options:	1	
	3250453	Nameplate (Prior to July 1987)		
	3251766	Nameplate (July 1987 to June 1992)		
	Not Required	Nameplate (June 1992 to Present)		
11		Decal - No Hands Options:	2	
	1700476	Decal (Prior to May 1994)		
	1702294	Decal (May 1994 to Present)		
12	Not Used			
13		Decal - Crushing Options:	4	
	1700585	Decal (Prior to May 1994)		
	1702277	Decal (May 1994 to Present)		
14		Decal - FWD Options:	4	
	1700053	Decal (Black) (Prior to November 1992)		
	Not Required	Decal (November 1992 to Present)		
15		Decal - Arrow Options:	4	
	1700058	Decal (Black) (Prior to November 1992)		
	1701529	Decal (Black/White) (November 1992 to Present)		
16	Not Used			
17	1700195	Decal - Hydraulic (Black)	1	
18	1701326	Decal - Tie-Down	4	

## SECTION 8 DECALS

FIGURE 8-2. DECALS INSTALLATION - DOMESTIC (BLACK) (CONTINUED)

FIG & ITEM #	PART NUMBER	DESCRIPTION	QTY.	REV.
19		Decal - Logo Options:	A/R	
	1700014	Decal (Prior to November 1989)	2	
	Not Required	Decal (November 1989 to Present)	0	
20	1701334	Decal - Black Stripe	40 Ft.	
21		Decal - Crushing Options:	2	
	1700640	Decal (Prior to May 1994)		
	1702284	Decal (May 1994 to Present)		
22	3820001	Rivet	A/R	
23	Not Used			
24	Not Used			
25		Decal - Electrocutation Hazard	3	
	1700580	Decal (Prior to May 1994)		
	1702292	Decal (May 1994 to Present)		
26	1700232	Decal - Lift Here	2	
27		Decal - Model 60H Options:	2	
	1701011	Prior to March 1992		
	1701753	March 1992 to Present		
28		Decal - JLG Lift Options:	3	
	1700349	Decal (Black) (Prior to March 1992)		
	1701685	Decal (Black) (March 1992 to Present)		
29	1700583	Decal - Ground Control Location	1	
30		Decal - Inspection Options:	1	
	1700593	Decal (Prior to May 1994)	1	
	1702153	Decal (May 1994 to Present)	1	
31	Not Used			
32	3251243	Nameplate - 120V	1	
33	0961127	Blushing, Snap	1	
34	0100010	Loctite, Adhesive (Not Shown)	A/R	
35	1701336	Decal - Full/Add (Black)	1	
36	Not Used			
37	0860520	Box, Manual Storage (Used July 1987 to Present)	1	
38	3311405	Locknut 1/4"-20NC	5	
39	4751400	Flatwasher 1/4"	6	
40	1060279	Cable, Lanyard	1	
41	0641408	Bolt 1/4"-20NC x 1"	1	
42		Decal Options:	1	
	1700014	Decal - Logo (Prior to November 1989)		
	3251813	Decal - USA (November 1989 to Present)		
43		Decal Options:	1	
	1700349	Decal - JLG Lift (Black) (Prior to November 1989)		
	1701321	Decal - JLG (Black) (November 1989 to Present)		
44	1700232	Decal - Lift Here (Prior to April 1995)	2	
45 to 53	Not Used			
54	1702282	Decal - Warning (Used May 1994 to Present)		
55	Not Available	Decal - Bar Code		
56	1702966	Decal - Unrestricted Capacity (S/N 34242 to Present)	2	
		-----		
	2900633	Decal Kit - Black (60H)	1	

# SECTION 8 DECALS

**FIGURE 8-2. DECALS INSTALLATION - DOMESTIC (BLACK) (CONTINUED)**

FIG & ITEM #	PART NUMBER	DESCRIPTION	QTY.	REV.
		<b>DECALS INSTALLATION (OPTIONAL PARTS)</b>	Ref.	
71	1700197	Decal - Fuel LP Gas	1	
72		Decal - Fuel Options:	1	
	1700194	Decal - Gas (Black)		
	1700196	Decal - Diesel (Black)		
73		Decal - Caution LP Gas Options:	1	
	3251028	Prior to March 1995		
	3252356	March 1995 to Present		
74		Nameplate - Caution Options:	1	
	3251606	Nameplate (2 Speed Machines with Racine Valves)		
	3251548	Nameplate (Single Speed Machines with Racine Valves)		
	3251548	Nameplate (Standard machines with Vickers Valves and PQ Controllers - Built Prior to October 1991)		
	3251607	Nameplate 9CSA/2:1 Stability Machines with Vickers Valves and PQ Controllers - Built Prior to October 1991)		
75	3251549	Nameplate - Danger (Machines Built Prior to October 1991)	1	
76		Nameplate - Caution/Danger Options:	1	
	3252144	Nameplate (Machines with PQ Controllers Built October 1991 to May 1994)		
	3252369	Nameplate (Machines with PQ Controllers Built May 1994 to Present)		
	3251775	Nameplate (Standard Machines with OEM Controllers Built Through		
	3251671	Nameplate (CSA/2:1 Stability Machines with OEM Controllers Built Through October 1991)		
	3252144	Nameplate (Machines with OEM Controllers built October 1991 to May 1994)		
	3252369	Nameplate (Machines with OEM Controllers Built May 1994 to Present)		
77		Mounting Bracket Options:	1	
	3530997	Bracket (Machines Built October 1991 to March 1993)		
	3536671	Bracket (Machines Built March 1993 to Present)		
	0251685	<b>LIFTING DIAGRAM INSTALLATION</b>	Ref.	-
101	3252095	Decal - Lifting Diagram	2	
	3820001	Rivet	8	

# SECTION 8 DECALS

FIGURE 8-3. DECALS INSTALLATION - LATIN AMERICA

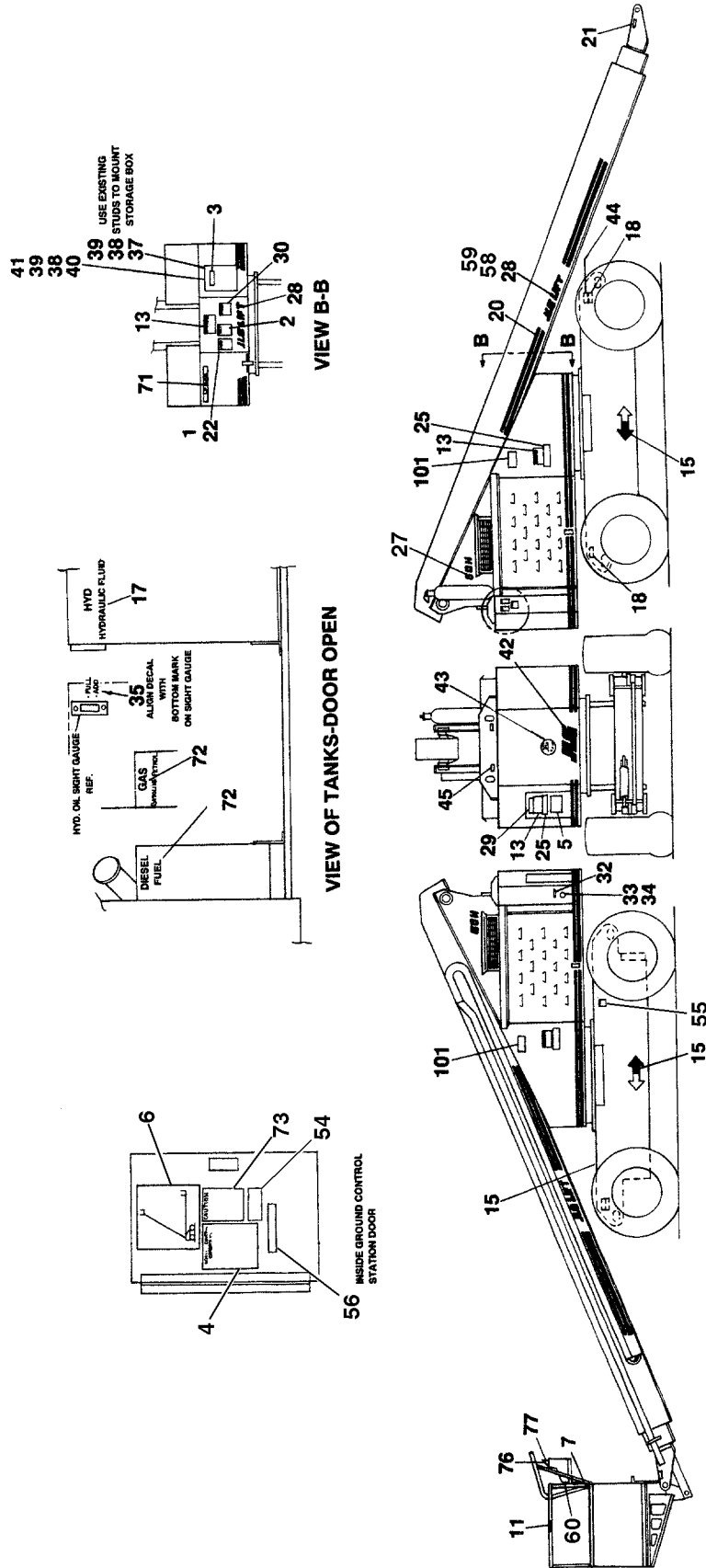

# SECTION 8 DECALS

**FIGURE 8-3. DECALS INSTALLATION - LATIN AMERICA**

FIG & ITEM #	PART NUMBER	DESCRIPTION	QTY.	REV.
		<b>DECALS INSTALLATION - LATIN AMERICA</b>	Ref.	
	0255740	<b>DECALS INSTALLATION - 60H WITH STANDARD CONTROLS</b>	Ref.	B
	0256018	<b>DECALS INSTALLATION - 60H+6 WITH STANDARD CONTROLS</b>	Ref.	B
		<b>DECALS INSTALLATION - 70H WITH STANDARD CONTROLS</b>	Ref.	
1	Consult Factory	Nameplate - Serial Number	1	
2	1702573	Decal - Patent	1	
3		Decal - Manual Options:	1	
	1701509	Prior to September 1995		
	1702598	September 1995 to Present		
4	1702606	Decal - Ground Control	1	
5	1702607	Decal - Caution	1	
6		Nameplate - Load/Reach Options:	1	
	3251587	Model 60H		
	3251758	Model 60H+6 (Prior to October 1995)		
	1701758	Model 60H+6 (October 1995 to Present)		
	3251657	Model 70H		
7		Decal - Attach Belt Options:	2	
	1702578	Prior to October 1995		
	1702690	October 1995 to Present		
8	Not Used			
9	Not Used			
10	3252489	Nameplate - Foot Switch	1	
11	1702586	Decal - No Hands	2	
12	Not Used			
13	1702609	Decal - Crushing	4	
14	Not Used			
15	1701529	Decal - Arrow	4	
16	Not Used			
17	1702599	Decal - Hydraulic	1	
18	1702604	Decal - Tie-Down	4	
19	Not Used			
20		Decal - Brown/Orange Stripe Options:	40 Ft.	
	1700431	Prior to October 1995		
	1701703	October 1995 to Present		
21	1702583	Decal - Crushing	2	
22	3820001	Rivet	A/R	
23	Not Used			
24	Not Used			
25	1702585	Decal - Electrocution Hazard	3	
26	Not Used			
27	Not Used	Decal - Model Options:	2	
	1701752	Decal - Model 60H		
	1701378	Decal - Model 60H+6		
	1701751	Decal - Model 70H		

## SECTION 8 DECALS

FIGURE 8-3. DECALS INSTALLATION - LATIN AMERICA (CONTINUED)

FIG & ITEM #	PART NUMBER	DESCRIPTION	QTY.	REV.
28	1701684	Decal - JLG Lift	3	
29	1702601	Decal - Ground Control Location	1	
30	1702552	Decal - Inspection	1	
31	Not Used			
32	1702590	Nameplate - 220V-50Hz	1	
33	0961127	Bushing, Snap	1	
34	0100010	Loctite, Adhesive (Not Shown)	A/R	
35	1702602	Decal - Full/Add	1	
36	Not Used			
37	0860520	Box, Manual Storage	1	
38	3311405	Locknut 1/4"-20NC	5	
39	4751400	Flatwasher 1/4"	6	
40	1060279	Cable, Lanyard	1	
41	0641408	Bolt 1/4"-20NC x 1"	1	
42	1700981	Decal JLG	1	
43	3251813	Decal - USA	1	
44		Decal - Lift Here Options:	2	
	1702603	Prior to September 1995		
	1702835	September 1995 to Present		
45		Decal Options:	1	
	1702598	Decal - Manual (Prior to September 1995)		
	1702603	Decal - Lift Here (September 1995 to Present)		
46 to 53	Not Used			
54	1702581	Decal - Warning	1	
55	Not Available	Decal - Bar Code	1	
56	1702663	Decal - Fan Blade	1	
57	1702720	Decal - LP Gas Liquid System	1	
58		Decal - Extend-A-Reach Options:	2	
	Not Required	Model 60H		
	1701375	Model 60H+6		
	Not Required	Model 70H		
59		Decal - JLG Options:	1	
	Not Required	Model 60H		
	1701110	Model 60H+6		
	Not Required	Model 70H		
60		Decal - 500 Lbs. Options:	1	
	Not Required	Model 60H		
	1701678	Model 60H+6		
	Not Required	Model 70H		
	2900633	Decal Kit - Brown (60H)	1	
	2900739	Decal Kit - Brown (70H)	1	
		<b>DECALS INSTALLATION (OPTIONAL PARTS)</b>	Ref.	
71		Decal - Fuel LP Gas	1	
	1700429	Prior to September 1995		
	1702721	September 1995 to Present		

# SECTION 8 DECALS

**FIGURE 8-3. DECALS INSTALLATION - LATIN AMERICA (CONTINUED)**

FIG & ITEM #	PART NUMBER	DESCRIPTION	QTY.	REV.
72		Decal - Fuel Options:	1	
		Decal - Gas (Brown) Options:		
	1700430	Prior to September 1995		
	1702722	September 1995 to Present		
	1702600	Decal - Diesel (Brown)		
73	3251028	Decal - Caution LP Gas	1	
74	Not Used			
75	Not Used			
76	1702608	Nameplate - Caution/Danger	1	
77	3536671	Mounting Bracket	1	
	0251685	<b>LIFTING DIAGRAM INSTALLATION</b>	Ref.	-
101	3252095	Decal - Lifting Diagram	2	
	3820001	Rivet	8	

# SECTION 8 DECALS

**FIGURE 8-3. DECALS INSTALLATION - LATIN AMERICA (CONTINUED)**

FIG & ITEM #	PART NUMBER	DESCRIPTION	QTY.	REV.



# SECTION 9 RECOMMENDED SERVICE PARTS STOCK

## MODELS 60H/60H+6/70 (STANDARD CONTROLS)

The following list will service fleets of machines (built to current production per date on the front cover) with emergency repair parts which can be installed in the field. Parts from the list should be replaced when inventory is depleted to keep service parts stock supplied. For further information, contact your JLG dealer or the JLG Industries Parts Department.

JLG PART NUMBER	DESCRIPTION	QTY PER FLEET		
		1-10	10-20	20 OR MORE
<b>STANDARD PARTS</b>				
7012339	Coil - Vickers Valve (Figure 2-9)	1	2	2
7000417	Coil - Bang-Bang Valve (Dump) (Figure 2-11)	1	2	2
7002450	Coil - Bang-Bang Valve (Dump) (Figure 2-12)	1	2	2
7000418	Coil - Bang-Bang Valve (Working) (Figures 2-11, 2-12, 2-13 and 2-14)	1	2	2
7004214	Element, Air Filter (Figures 2-25)	1 doz.	1 doz.	1 doz.
3740067	Relay (Figures 2-25 and 2-32)	1	1	1
1340046	Breather, Tank (Figure 2-40)	2 per machine	2 per machine	2 per machine
2120107	Element, Hydraulic Oil Filter (Figure 2-40)	2 per machine	2 per machine	2 per machine
3740049	Relay - SPDT (Figures 2-43 and 4-6)	1	1	2
3740016	Relay - 3PDT (Figure 2-43)	1	1	2
4360186	Breaker, Circuit - 35 Amp (Figure 2-43)	1	1	2
4360069	Breaker, Circuit - 10 Amp (Figure 2-43)	1	1	2
4360466	Switch, Key (Figure 2-43)	1	1	2
2860030	Key (Figure 2-43)	2	4	6
4360199	Switch, Toggle (Figures 2-43 & 4-6)	1	1	2
4360274	Switch, Push Button (Figures 2-43 & 4-6)	1	1	2
4360202	Switch, Toggle (Figures 2-43 & 4-6)	1	1	2
4360201	Switch, Toggle (Figure 2-43)	1	1	2
4360200	Switch, Toggle (Figures 2-43 & 4-6)	1	1	2
4360057	Switch, Llimit (Figure 2-45)	1	1	2
4360171	Switch, Tilt Indicator (Figure 2-45)	1	1	2
70003147	Power Track - Section Repair Kit (6 Links) (Figure 3-1)	2	2	2
2940006	Latch, Platform Door (Figures 4-1 and 4-2)	1	1	1
4360031	Footswitch (Figures 4-1 and 4-2)	1	1	1
4360209	Breaker, Circuit - 20 Amp (Figure 4-6)	1	1	2
1600141	Controller, PQ (Figure 4-6)	1	1	1
7011907	Electrical Assembly - 1600141 Controller (Figure 4-6)	1	2	2
4360475	Switch, Mushroom (Figure 4-6)	1	1	2
4360476	Block, Switch Contact (Figure 4-6)	1	1	2
3990010	Diode - 6 Amp (Figure 7-1)	4	6	8
<b>VARIABLE PARTS</b>				
7029276	Filter, Engine Oil (Deutz) (Figure 2-25)	1 Case	1 Case	1 Case
7008828	Cable, Throttle (Deutz) (Figure 2-26)	1	1	1
7008829	Board, PC (Deutz) (Figure 2-26)	1	1	1
1600211	Control Module (Ford) (Figure 2-32)	1	1	1
3740059	Relay (Deutz) (Figure 2-25)	1	1	1
7012681	Module, Ignition (Ford) (Figure 2-32)	1	1	1

## SECTION 9 RECOMMENDED SERVICE PARTS STOCK

## MODELS 60H/60H+6/70 (STANDARD CONTROLS)

The following list will service fleets of machines (built to current production per date on the front cover) with emergency repair parts which can be installed in the field. Parts from the list should be replaced when inventory is depleted to keep service parts stock supplied. For further information, contact your JLG dealer or the JLG Industries Parts Department.

JLG PART NUMBER	DESCRIPTION	QTY PER FLEET		
		1-10	10-20	20 OR MORE
7014501	Filter, Engine Oil (Ford) (Figure 2-32)	1 case	1 case	1 case
1660249	Coupling (Ford) (Figure 2-32)	1	1	1
1660183	Coupling (Deutz) (Figure 2-35)	1	1	1
1060369	Cable, Capacity Indicator (Standard Platform) (Figure 4-9)	1	1	1
1060417	Cable, Capacity Indicator (Low Mount Platform) (Figure 4-9)	1	1	1
4360212	Breaker, Circuit - 3 Amp (Deutz) (Figure 7-1)	1	1	2

# SECTION 10 SPECIAL OPTIONS

<b>TABLE OF CONTENTS</b>				
FIGURE NO.	DESCRIPTION	PAGE NO.		
10-1	Special Options List . . . . .	10-1		
10-2	EN280/CE/Euro/Australian Spec Components . . . . .	10-6		
10-3	Japanese/Chinese Spec Components . . . . .	10-9		
<b>FIGURE 10-1.SPECIAL OPTIONS LIST</b>				
Note: This list is to accomodate machines ordered with special equipment. Options may not be applicable to all models. For more specific parts information contact JLG Parts Department.				
FIG & ITEM #	PART NUMBER	DESCRIPTION	QTY.	REV.
		<b>MISCELLANEOUS SPECIAL OPTIONS</b>	Ref.	
	0236221	<b>Air Cleaner Installation - Hostile Environment/Deutz Engines</b>	Ref.	B
	0237063	<b>Air Cleaner Service Indicator Installation</b>	Ref.	-
		<b>Airline to Platform Installations</b>	Ref.	
	0237140	1/2" Airline Installation - 60H	Ref.	6
	0239263	1/2" Airline Installation - 60H+6	Ref.	C
	0237162	1/2" Airline Installation - 70H	Ref.	6
	0237141	3/4" Airline Installation - 60H	Ref.	3
	0237163	3/4" Airline Installation - 70H	Ref.	3
	0252569	<b>Alternator Installation - Totally Enclosed (Cumins)</b>	Ref.	A
	0270723	<b>Beacon (Amber) on Platform Installation</b>	Ref.	1
	0800930	<b>Boom Assembly - With Inverted Powertrack</b>	Ref.	-
	0255181	<b>Boom Installation - With Inverted Powertrack</b>	Ref.	-
	0239570	<b>Brush Installation - T/T Bearing (S/N 11866)</b>	Ref.	B
	0256789	<b>Camera Mount Assembly</b>	Ref.	3
	0250729	<b>Capacity Decals Installation - Platform Mounted</b>	Ref.	B
		<b>Capacity Decals Installation - Platform Gate and Control Box Mounted</b>	Ref.	
	0239776	Capacity Decals Installation - 60H (650 Lbs.) (S/N 11028 and 11866)	Ref.	D
	0251982	Capacity Decals Installation - 60H (750 Lbs.)	Ref.	C
	0251799	Capacity Decals Installation - 70H (600 Lbs.)	Ref.	E

# SECTION 10 SPECIAL OPTIONS

SECTION 10 SPECIAL OPTIONS

0253634	Cover Installation - Metal Console (60H)	Ref.	
0256260	Cover Installation - Metal Console (60H+6)	Ref.	
0239418	Contactor Box and Relay Installation - U/L	Ref.	A
0254467	Cover Installation - T/T Bearing and Pinion (First Used on S/N 17555)	Ref.	A
	<b>Decal Installations</b>	Ref.	
0253550	CSA Decal Installation	Ref.	-
3252221	Decal - CSA	1	
0256487	Decal - Prop 65 (Diesel)	Ref.	2
1702962	Decal	1	
0256488	Decal - Prop 65 (Gas)	Ref.	A
1702961	Decal	1	
0256018	Decal Installation (Brown) (Argentina)	Ref.	
1702669	Decal - Important (Argentina)	Ref.	
1702724	Decal - Reach (Argentina)	Ref.	
1702600	Decal - Fuel Diesel (Brown) (Argentina)	Ref.	
1702721	Decal - LP Gas (Brown) (Argentina)	Ref.	
1702722	Decal - Fuel Gas (Brown) (Argentina)	Ref.	
	<b>Engine Assembly and Installations - Specials</b>	Ref.	
0239497/ 0239498	Engine Assembly/Installation - Cummins Diesel	Ref.	RL-D
0236744/ 0236745	Engine Assembly/Installation - Ford Dual Fuel with Piston Pump and Racine Valves	Ref.	E/G
0237936/ 0254231	Engine Assembly/Installation - Ford Gas with Larger Auxiliary Pump and 75 Amp Battery (Westinghouse Machines)	Ref.	
	<b>Engine Heaters Installations</b>	Ref.	
	<b>Deutz Engines:</b>		
0237501	Oil Heater Installation (Prior to June 1995)	Ref.	C
0252654	Oil Heater Installation (June 1995 to Present)	Ref.	A
0237481	Battery Heater Installation (Prior to June 1995)	Ref.	B
0238779	Battery Heater Installation (June 1995 to Present)	Ref.	A
0239194	Cold Weather Start Kit Installation	Ref.	B
	<b>Ford Engines:</b>		
	<b>Battery and Engine Heaters Installations</b>	Ref.	
0236874	Prior to June 1995	Ref.	B
0238777	June 1995 to Present	Ref.	D
	<b>Exhaust Installations - Specials</b>	Ref.	
	<b>Deutz Engines:</b>		
0250632	Exhaust Purifier Installation (Prior to April 1993)	Ref.	A
0254109	Exhaust Purifier Installation (April 1993 to Present)	Ref.	3
0235110	Spark Arrester Installation (Prior to January 1992)	Ref.	A
0252736	Spark Arrester Installation (January 1992 to Present)	Ref.	-

# SECTION 10 SPECIAL OPTIONS

		<b>Ford Engines:</b>		
	0237014	<b>Oxy Catalyst Purifier Installation</b>	Ref.	-
	0255072	<b>Fan Shield Installation - Ford Engine</b>	Ref.	-
		<b>Filter Kits:</b>	Ref.	
	1001110984	Combined Filter Kit (Hydraulic/Air & Fuel/Engine Oil)	1	
	1001109673	Hydraulic/Air Filter	1	
	1001110131	Engine - Fuel/Engine Oil Filter	1	
	0254187	<b>Fire Extinguisher Installation</b>	Ref.	-
	0255869	<b>Fuel Fill Extension Installation</b>	Ref.	
	0250150	<b>Fuel Indicator Light at Platform Installation - LP</b>	Ref.	
		<b>Generator Installations - Special</b>	Ref.	
	0250294	<b>Generator Installation - With Ground Fault Interrupt (GFI) and Weatherproof Box (Deutz Engines)</b>	Ref.	
	0250396	<b>Generator Installation - U/L (Ford Engines)</b>	Ref.	-
	0255542	<b>Ground Control Box Installation - UL (Ford Engines)</b>	Ref.	-
	0860927	<b>Ground Control Box Assembly</b>	1	
	4360295	<b>Ignition Switch with Individual Coded Keys</b>	Ref.	-
	0251081	<b>Ladder Installation (S/N 13952)</b>	Ref.	-
		<b>Lights Installation - Special</b>	Ref.	
	0250476	<b>Back-up Light Installation</b>	Ref.	2
	0254186	<b>Beacon Lights - Dual (Westinghouse Machines)</b>	Ref.	-
	0254097	<b>Brake Lights Installation</b>	Ref.	A
	0236662	<b>Headlights and Taillights Installation (Prior to March 1993)</b>	Ref.	D
	0254084	<b>Headlights and Taillights Installation (March 1993 to Present)</b>	Ref.	A
	0238662	<b>Headlights and Taillights Installation - U/L</b>	Ref.	2
	0251084	<b>Headlights and Taillights Installation - Front and Rear (S/N 13941)</b>	Ref.	-
	0237064	<b>Panel Lights Installation (On Ground and Platform Control Boxes)</b>	Ref.	C
	0254096	<b>Turn Signals Installation</b>	Ref.	A
	0237650	<b>Locks Installation - Hoods</b>	Ref.	C
	0254852	<b>Locks Installation - Turntable (90°)</b>	Ref.	-

# SECTION 10 SPECIAL OPTIONS

**SECTION 10 SPECIAL OPTIONS**

		<b>Oil Cooler Installations</b>	Ref.	
0236610		Oil Cooler Installation - Mounted at Rear of T/T	Ref.	C
0254853		Oil Cooler Installation - Mounted Inside of T/T	Ref.	5
0237187		Oil Cooler Filter Installation	Ref.	B
1281434		<b>Overload Pressures Switches Installation</b>	Ref.	A
0238488		Standard Controls	Ref.	A
0251816		Hydraulic Controls	Ref.	-
0254981		<b>Padding Installation - Platform (Without Bumper)</b>	Ref.	-
0237064		<b>Panel Lights Installation</b>	Ref.	C
2940024		Light, Panel	3	
0256436		<b>Pipe Rack Installation</b>	Ref.	2
0238669		<b>Platform Installation - Special Low Mount (S/N's 11000 and 11001)</b>	Ref.	B
1281196		<b>Platform (Welded-On) Kickplates Installation - Low Mount Platform</b>	Ref.	A
0250257		3' x 5' Platform	Ref	-
0250261		3' x 6' Platform	Ref.	-
0250262		3' x 8' Platform	Ref.	-
1281167		<b>Platform (Bolt-On) Kickplates Installation</b>	Ref.	A
0250707		3' x 5' Standard Platform	Ref.	A
0250708		3' x 6' Standard Platform	Ref.	A
0250709		3' x 8' Standard Platform	Ref.	A
0250731		3' x 5' Low Mount Platform	Ref.	-
0250730		3' x 6' Low Mount Platform	Ref.	-
0250732		3' x 8' Low Mount Platform	Ref.	-
0252699		<b>Power Track Installation - With Chip Covers</b>	Ref.	A
0254864		<b>Power Track Boot Installation - 60H</b>	Ref.	A
0254602		<b>Power Track Boot Installation - 70H</b>	Ref.	A
0251140		<b>Receptacle at Ground Controls Installation (GFI)</b>	Ref.	C
0254189		<b>Receptacle (Dual) at Platform Installation</b>	Ref.	A
0254426		<b>Receptacle &amp; AC Power Cord Installation</b>	Ref.	3
0238954/ 0238961		<b>Remote Control Assembly/Installation - Special Remote Control Assembly/Installation - Drive and Steer on a Remote Box</b>	Ref. Ref.	 A
0251082		<b>Remote Control Boxes Installation - Platform Controls on a Remote Box</b>	Ref.	-
0251096		Junction Box Assembly	Ref.	-
0251097		Remote Box Assembly	Ref.	-

# SECTION 10 SPECIAL OPTIONS

0237411	<b>Remote Oil Filter and Drain Installation - Ford Engines</b>	Ref.	-
0254187	<b>Slow Moving Vehicle Sign Installation</b>	Ref.	-
0254188	<b>Tachometer at Ground Installation</b>	Ref.	A
	<b>Tanks Installations (Fuel and Oil) - Specials</b>	Ref.	
0236734	<b>Tanks Installation - Piston Pump Machines</b>	Ref.	A
0256389	<b>Tanks Installation - U/L DS Rating Machines</b>	Ref.	-
0258836	<b>U/L 25 Gallon Tank Fuel Installation</b>	Ref.	
0256390	<b>Tank - 25 Gallon Assembly</b>	1	
0239139	<b>Tanks Installation - U/L Diesel Machines</b>	Ref.	B
0254180	<b>Tanks Installation - Westinghouse Machines</b>	Ref.	-
	<b>Tank Shrouds Installation (LP) - Specials</b>	Ref.	
0251234	<b>Tank Shrouds Installation (Both Tanks T/T Mounted)</b>	Ref.	A
0238661	<b>Tank Shrouds Installation (Aux Tank Frame Mounted) (U/L Listed)</b>	Ref.	B
0254203	<b>Tilt Alarm With Cut-Out Installation</b>	Ref.	-
	<b>Tools:</b>	Ref.	
7004275	Seal Tool 1"	1	
7004276	Seal Tool 1 1/2"	1	
7002826	Seal Tool 2"	1	
7002828	Stripper, Wire	1	
0250223	<b>Tow Package - Boeing Airlines</b>	Ref.	-
0257728	<b>Tube Rack</b>	Ref.	-
1281028	<b>U/L Tags Installations</b>	Ref.	
0250180	<b>Dual Fuel Machines</b>	Ref.	A
0239506	<b>LP Only Machines</b>	Ref.	A
0239507	<b>Diesel Machines</b>	Ref.	B
0258918	<b>Utility Rack Installation</b>	Ref.	1
0238670	<b>Valves Installation - U/L Vickers Valve Machines</b>	Ref.	B
0250938	<b>Valves (Frame Mounted) Installation - With 3 Flow Dividers and Auxiliary Pump (S/N's 13915, 13916, 13924, 13925 and 13926)</b>	Ref.	A
0250123	<b>Waterline to Platform Installation (S/N 12452)</b>	Ref.	A
0237682	<b>Weld Cables Installation - 60H</b>	Ref.	3
0251077	<b>Weld Cables Installation - 70H</b>	Ref.	3
0251083	<b>Wheel Drive Installation - 5MPH Drive Speed (S/N 13943)</b>	Ref.	A

## SECTION 10 SPECIAL OPTIONS

**FIGURE 10-2. EN280/CE/EURO/AUSTRALIAN SPEC COMPONENTS**

FIG & ITEM #	PART NUMBER	DESCRIPTION	QTY.	REV.
10-2		<b>MISCELLANEOUS SPECIAL OPTIONS</b>	Ref.	
		<b>EN280/CE/EURO/AUSTRALIAN SPEC COMPONENTS</b>	Ref.	
		<b>SECTION 1 - FRAME</b>		
		0253572 Tire & Wheel 15 x 19.5 Assembly - Foam Filled (Model 70H)	Ref.	
		<b>SECTION 2 - TURNTABLE</b>		
		0236438 Boom Installation - Model 60H (Australian Spec)	Ref.	
		0237995 Boom Installation - Model 60H+6 (Australian Spec)	Ref.	
		0253046 Boom Installation - Model 60H (Euro Spec)	Ref.	
		0253048 Boom Installation - Model 60H+6 (Euro Spec)	Ref.	
		0253377 Boom Installation - Model 70H (Euro Spec)	Ref.	
		0254855 Boom Cylinder Installation - With Invert Power Track (Euro Spec)	Ref.	
		0253390 Engine Installation - Deutz F3L912	Ref.	
		0253930 Ground Control Box Installation (Euro Spec)	Ref.	
		0253430 Ground Control Box Installation (Model 70H) (Australian Spec)	Ref.	
		0251092 Tilt Indicator 3 Degree Installation (Euro Spec)	Ref.	
		0253367 Horizontal Limit Switch Cut-Out Installation (Euro Spec)	Ref.	
		0253368 Limit Switch 8 Meter Drive Cut-Out Installation (Australian/German/Dutch Spec)	Ref.	
		0253369 Limit Switch 3 Meter Tele Drive Cut-Out Installation (Italian Spec) (Model 60H/60H+6)	Ref.	
		0253379 Limit Switch 3 Meter Tele Drive Cut-Out Installation (Italian Spec) (Model 70H)	Ref.	
		2790946 Manual Descent Installation (Australian Spec)	Ref.	
		0253384 Manual Descent Installation (Euro Spec)	Ref.	
		0254457 Amber Strobe Light Installation (Hood) (Australian Spec)	Ref.	
		0254853 Oil Cooler Under Hood Installation - Model 70H (Australian Spec)	Ref.	
		<b>SECTION 3 - BOOM</b>		
		0253045 Aux. Boom Chain Installation (60H)	Ref.	
		0253047 Aux. Boom Chain Installation (60H+6)	Ref.	
		0253364 Aux. Boom Chain Installation (70H)	Ref.	
		0800392 Boom Assembly (60H)	Ref.	
		0800505 Boom Assembly (60H+6)	Ref.	
		0800418 Boom Assembly (70H)	Ref.	
	<b>SECTION 4 - PLATFORM</b>			
	0254417 AC Power Cord Installation - Model 60H (Euro/Australian Spec)	Ref.		
	0254427 AC Power Cord Installation - Model 60H+6/70H (Euro/Australian Spec)	Ref.		
	0860738 Console Box Assembly - PQ (2WS) (Euro Spec)	Ref.		



# SECTION 10 SPECIAL OPTIONS

FIG & ITEM #	PART NUMBER	DESCRIPTION	QTY.	REV.
	0860786	Console Box Assembly - Prop Tele (2WS) (Euro Spec)	Ref.	
	0860787	Console Box Assembly - PQ (4WS) (Euro Spec)	Ref.	
	0860788	Console Box Assembly - Prop Tele (4WS) (Euro Spec)	Ref.	
	3510296	Platform - 36 x 60 (Standard Mount)	Ref.	
	3510297	Platform - 36 x 72 (Standard Mount)	Ref.	
	3510298	Platform - 36 x 96 (Standard Mount)	Ref.	
	3510299	Platform - 36 x 60 (Extend-A-Reach)	Ref.	
	3510300	Platform - 36 x 72 (Extend-A-Reach)	Ref.	
	3510304	Platform - 36 x 60 (Low Mount)	Ref.	
	3510305	Platform - 36 x 72 (Low Mount)	Ref.	
	3510306	Platform - 36 x 96 (Low Mount)	Ref.	
	0255729	Capacity Indicator Installation	Ref.	
	0253558	Receptacle Mounting Plate Installation (Australian Spec)	Ref.	
	0251180	Platform Interlock System (French Spec)	Ref.	
	0256112	Rotator Support Installation - 60H+6 (French Spec)	Ref.	
	0253747	Safe Load System Installation (French Spec) (Prior to S/N 36621)	Ref.	
	0258039	Safe Load System Installation (French Spec) (S/N 36621 to Present)	Ref.	
	0255566	Platform Over Load System Installation (Standard Control)	Ref.	
	0255567	Platform Over Load System Installation (Hydraulic Control)	Ref.	
		<b>SECTION 5 - CYLINDERS</b>		
		<b>Bellows Installations:</b>	Ref.	
	0253136	Fix Axle 2WD (Australian Spec)	Ref.	
	0253137	Oscillating Axle 2WD (Australian Spec)	Ref.	
	0253138	Fix Axle 4WD (Australian Spec)	Ref.	
	0253139	Oscillating Axle 4WD (Australian Spec)	Ref.	
	0253140	Fix Axle 2WD/4WS (Australian Spec)	Ref.	
	0253141	Oscillating Axle 2WD/4WS (Australian Spec)	Ref.	
	0253142	Fix Axle 4WD/4WS (Australian Spec)	Ref.	
	0253143	Oscillating Axle 4WD/4WS (Australian Spec)	Ref.	
	0253150	Fix Axle 2WD (Extend-A-Reach) (Australian Spec)	Ref.	
	0253151	Oscillating Axle 2WD (Extend-A-Reach) (Australian Spec)	Ref.	
	0253152	Fix Axle 4WD (Extend-A-Reach) (Australian Spec)	Ref.	
	0253153	Oscillating Axle 4WD (Extend-A-Reach) (Australian Spec)	Ref.	
	0253154	Fix Axle 2WD/4WS (Extend-A-Reach) (Australian Spec)	Ref.	
	0253155	Oscillating Axle 2WD/4WS (Extend-A-Reach) (Australian Spec)	Ref.	
	0253156	Fix Axle 4WD/4WS (Extend-A-Reach) (Australian Spec)	Ref.	
	0253157	Oscillating Axle 4WD/4WS (Extend-A-Reach) (Australian Spec)	Ref.	

# SECTION 10 SPECIAL OPTIONS

FIG & ITEM #	PART NUMBER	DESCRIPTION	QTY.	REV.
		<b>SECTION 7 - ELECTRICAL</b>		
	4932667	Electrical Modification (Australian Spec)	Ref.	
	4932492	Electrical Modification (French Spec)	Ref.	
	4932430	Electrical Wiring Diagram M.T.B. (Euro Spec)	Ref.	
	4932431	Electrical Wiring Diagram Platform (2W/S Without Prop Tele) (Euro Spec)	Ref.	
	4932502	Electrical Wiring Diagram Platform (2W/S With Prop Tele) (Euro Spec)	Ref.	
	4932503	Electrical Wiring Diagram Platform (4W/S Without Prop Tele) (Euro Spec)	Ref.	
	4932504	Electrical Wiring Diagram Platform (4W/S With Prop Tele) (Euro Spec)	Ref.	
	4932639	Electrical Wiring Diagram Motion Alarm (Australian)	Ref.	
	4932898	Electrical Wiring Diagram Safe Load Indicator System (French Spec) (Prior to S/N 36621)	Ref.	
	4933007	Electrical Wiring Diagram Safe Load Indicator System (French Spec) (S/N 36621 to Present)	Ref.	
	4931713	Electrical Wiring Diagram Over Load System (Standard Control)	Ref.	
	4932073	Electrical Wiring Diagram Over Load System (Hydraulic Control)	Ref.	
		<b>SECTION 8 - DECALS</b>		
	0253009	Decal Installation - 60H (Brown)	Ref.	
	0254406	Decal Installation - 60H (Australian Spec)	Ref.	
	0253014	Decal Installation - 60H (Dutch Spec)	Ref.	
	0253010	Decal Installation - 60H (English U.K. Spec)	Ref.	
	0253011	Decal Installation - 60H (French Spec)	Ref.	
	0253012	Decal Installation - 60H (German/Australian Spec)	Ref.	
	0253013	Decal Installation - 60H (Italian Spec)	Ref.	
	0253282	Decal Installation - 60H (Spanish Spec)	Ref.	
	0253020	Decal Installation - 60H+6 (Brown)	Ref.	
	0257113	Decal Installation - 60H+6 (Australian Spec)	Ref.	
	0253025	Decal Installation - 60H+6 (Dutch Spec)	Ref.	
	0253021	Decal Installation - 60H+6 (English U.K. Spec)	Ref.	
	0253022	Decal Installation - 60H+6 (French Spec)	Ref.	
	0253023	Decal Installation - 60H+6 (German/Australian Spec)	Ref.	
	0253024	Decal Installation - 60H+6 (Italian Spec)	Ref.	
	0253285	Decal Installation - 60H+6 (Spanish Spec)	Ref.	
	0252991	Decal Installation - 70H	Ref.	
	0257113	Decal Installation - 70H (Australian Spec)	Ref.	
	0252996	Decal Installation - 70H (Dutch Spec)	Ref.	
	0252992	Decal Installation - 70H (English U.K. Spec)	Ref.	
	0252993	Decal Installation - 70H (French Spec)	Ref.	
	0252994	Decal Installation - 70H (German/Australian Spec)	Ref.	
	0255771	Decal Installation - 70H (270kg) (German Spec)	Ref.	
	0252995	Decal Installation - 70H (Italian Spec)	Ref.	
	0253305	Decal Installation - 70H (Spanish Spec)	Ref.	
	1701505	Decal - Diesel (Euro Spec)	Ref.	

# SECTION 10 SPECIAL OPTIONS

**FIGURE 10-3. JAPANESE/CHINESE SPEC COMPONENTS**

FIG & ITEM #	PART NUMBER	DESCRIPTION	QTY.	REV.	
10-3		<b>MISCELLANEOUS SPECIAL OPTIONS</b>	Ref.		
		<b>JAPANESE/CHINESE SPEC COMPONENTS</b>	Ref.		
		<b>SECTION 2 - TURNTABLE</b>			
		0253390	Engine Installation - Deutz F3L912	Ref.	
		0253367	Horizontal Limit Switch Cut-Out Installation	Ref.	
		0254313	Tilt Indicator 5 Degree Installation	Ref.	
		0253384	Manual Descent Installation	Ref.	
			<b>SECTION 4 - PLATFORM</b>		
		0254416	AC Power Cord Installation - Model 60H/60H+6	Ref.	
		0254426	AC Power Cord Installation - Model 70H	Ref.	
		0860738	Console Box Assembly - PQ (2WS) (Japanese Spec)	Ref.	
		0860786	Console Box Assembly - Prop Tele (2WS) (Japanese Spec)	Ref.	
		0860787	Console Box Assembly - PQ (4WS) (Japanese Spec)	Ref.	
		0860788	Console Box Assembly - Prop Tele (4WS) (Japanese Spec)	Ref.	
		3510296	Platform - 36 x 60 (Standard Mount)	Ref.	
		3510297	Platform - 36 x 72 (Standard Mount)	Ref.	
		3510298	Platform - 36 x 96 (Standard Mount)	Ref.	
		3510299	Platform - 36 x 60 (Extend-A-Reach)	Ref.	
		3510300	Platform - 36 x 72 (Extend-A-Reach)	Ref.	
		3510304	Platform - 36 x 60 (Low Mount)	Ref.	
		3510305	Platform - 36 x 72 (Low Mount)	Ref.	
		3510306	Platform - 36 x 96 (Low Mount)	Ref.	
			<b>SECTION 7 - ELECTRICAL</b>		
		0255975	AC Receptacle Box Installation (Japanese Spec)	Ref.	
		4932635	Electrical Modification (Japanese)	Ref.	
		4932639	Electrical Wiring Diagram Motion Alarm (Japanese)	Ref.	
			<b>SECTION 8 - DECALS</b>		
		0253009	Decal Installation - 60H (Brown)	Ref.	
		0253283	Decal Installation - 60H (Japanese Spec)	Ref.	
		0253020	Decal Installation - 60H+6 (Brown)	Ref.	
		0253286	Decal Installation - 60H+6 (Japanese Spec)	Ref.	
		0252991	Decal Installation - 70H (Japanese Spec)	Ref.	
	0257430	Decal Installation - 70H (Chinese Spec)	Ref.		
	0253306	Decal Installation - 70H (Japanese Spec)	Ref.		

# SECTION 10 SPECIAL OPTIONS

**S  
E  
C  
T  
I  
O  
N  
  
1  
0  
  
S  
P  
E  
C  
I  
A  
L  
  
O  
P  
T  
I  
O  
N  
S**

FIG & ITEM #	PART NUMBER	DESCRIPTION	QTY.	REV.





3120290



An Oshkosh Corporation Company

Corporate Office  
JLG Industries, Inc.  
1 JLG Drive  
McConnellsburg PA. 17233-9533  
USA

☎ (717) 485-5161

📠 (717) 485-6417

## JLG Worldwide Locations

JLG Industries (Australia)  
P.O. Box 5119  
11 Bolwarra Road  
Port Macquarie  
N.S.W. 2444  
Australia

☎ +61 2 65 811111

📠 +61 2 65 813058

JLG Latino Americana Ltda.  
Rua Eng. Carlos Stevenson,  
80-Suite 71  
13092-310 Campinas-SP  
Brazil

☎ +55 19 3295 0407

📠 +55 19 3295 1025

JLG Industries (UK) Ltd  
Bentley House  
Bentley Avenue  
Middleton  
Greater Manchester  
M24 2GP - England

☎ +44 (0)161 654 1000

📠 +44 (0)161 654 1001

JLG France SAS  
Z.I. de Baulieu  
47400 Fauillet  
France

☎ +33 (0)5 53 88 31 70

📠 +33 (0)5 53 88 31 79

JLG Deutschland GmbH  
Max-Planck-Str. 21  
D - 27721 Ritterhude - Ihlpohl  
Germany

☎ +49 (0)421 69 350 20

📠 +49 (0)421 69 350 45

JLG Equipment Services Ltd.  
Rm 1107 Landmark North  
39 Lung Sum Avenue  
Sheung Shui N. T.  
Hong Kong

☎ (852) 2639 5783

📠 (852) 2639 5797

JLG Industries (Italia) s.r.l.  
Via Po. 22  
20010 Pregnana Milanese - MI  
Italy

☎ +39 029 359 5210

📠 +39 029 359 5845

Oshkosh-JLG Singapore  
Technology Equipment Pte  
Ltd  
29 Tuas Ave 4,  
Jurong Industrial Estate  
Singapore, 639379

☎ +65-6591 9030

📠 +65-6591 9031

Plataformas Elevadoras  
JLG Iberica, S.L.  
Trapadella, 2  
P.I. Castellbisbal Sur  
08755 Castellbisbal, Barcelona  
Spain

☎ +34 93 772 4700

📠 +34 93 771 1762

JLG Sverige AB  
Enkopingsvagen 150  
Box 704  
SE - 176 27 Jarfalla  
Sweden

☎ +46 (0)850 659 500

📠 +46 (0)850 659 534