



An Oshkosh Corporation Company

---

# ***Operation and Safety Manual***

*Original Instructions - Keep this manual with the machine at all times.*

***Model***  
***1250AJP***  
***PVC 2001***

---

**ANSI** **CE**  **AS/NZS**

The AS/NZS logo consists of a globe with a stylized 'S' and 'A' inside it, representing the Australian and New Zealand Standards.

**31215057**  
*August 26, 2020 - Rev C*



## WARNING

Operating, servicing and maintaining this vehicle or equipment can expose you to chemicals including engine exhaust, carbon monoxide, phthalates, and lead, which are known to the State of California to cause cancer and birth defects or other reproductive harm. To minimize exposure, avoid breathing exhaust, do not idle the engine except as necessary, service your vehicle or equipment in a well-ventilated area and wear gloves or wash your hands frequently when servicing. For more information go to [www.P65Warnings.ca.gov](http://www.P65Warnings.ca.gov).

## **FOREWORD**

The Mobile Elevating Work Platform (MEWP) models covered in this manual are designed and tested to meet or exceed various compliance standards. Please refer to the manufacturer's nameplate affixed to the subject MEWP for specific standard compliance information.

This manual is a very important tool! Keep it with the machine at all times.

The purpose of this manual is to provide owners, users, operators, lessors, and lessees with the precautions and operating procedures essential for the safe and proper machine operation for its intended purpose.

Due to continuous product improvements, JLG Industries, Inc. reserves the right to make specification changes without prior notification. Contact JLG Industries, Inc. for updated information.

Refer to [www.JLG.com](http://www.JLG.com) for Warranty, Product Registration, and other machine-related documentation.

## **SAFETY ALERT SYMBOLS AND SAFETY SIGNAL WORDS**



This is the Safety Alert Symbol. It is used to alert you to the potential personal injury hazards. Obey all safety messages that follow this symbol to avoid possible injury or death

### **⚠ DANGER**

INDICATES AN IMMINENTLY HAZARDOUS SITUATION. IF NOT AVOIDED, WILL RESULT IN SERIOUS INJURY OR DEATH. THIS DECAL WILL HAVE A RED BACKGROUND.

### **⚠ WARNING**

INDICATES A POTENTIALLY HAZARDOUS SITUATION. IF NOT AVOIDED, COULD RESULT IN SERIOUS INJURY OR DEATH. THIS DECAL WILL HAVE AN ORANGE BACKGROUND.

### **⚠ CAUTION**

INDICATES A POTENTIALLY HAZARDOUS SITUATION. IF NOT AVOIDED, MAY RESULT IN MINOR OR MODERATE INJURY. IT MAY ALSO ALERT AGAINST UNSAFE PRACTICES. THIS DECAL WILL HAVE A YELLOW BACKGROUND.

### **NOTICE**

INDICATES INFORMATION OR A COMPANY POLICY THAT RELATES DIRECTLY OR INDIRECTLY TO THE SAFETY OF PERSONNEL OR PROTECTION OF PROPERTY.



**⚠ WARNING**

**THIS PRODUCT MUST COMPLY WITH ALL SAFETY RELATED BULLETINS. CONTACT JLG INDUSTRIES, INC. OR THE LOCAL AUTHORIZED JLG REPRESENTATIVE FOR INFORMATION REGARDING SAFETY-RELATED BULLETINS WHICH MAY HAVE BEEN ISSUED FOR THIS PRODUCT.**

**NOTICE**

**JLG INDUSTRIES, INC. SENDS SAFETY RELATED BULLETINS TO THE OWNER OF RECORD OF THIS MACHINE. CONTACT JLG INDUSTRIES, INC. TO ENSURE THAT THE CURRENT OWNER RECORDS ARE UPDATED AND ACCURATE.**

**NOTICE**

**JLG INDUSTRIES, INC. MUST BE NOTIFIED IMMEDIATELY IN ALL INSTANCES WHERE JLG PRODUCTS HAVE BEEN INVOLVED IN AN ACCIDENT INVOLVING BODILY INJURY OR DEATH OR WHEN SUBSTANTIAL DAMAGE HAS OCCURRED TO PERSONAL PROPERTY OR THE JLG PRODUCT.**

**For:**

- Accident Reporting
- Product Safety Publications
- Current Owner Updates
- Questions Regarding Product Safety
- Standards and Regulations Compliance Information
- Questions Regarding Special Product Applications
- Questions Regarding Product Modifications

**Contact:**

Product Safety and Reliability Department  
JLG Industries, Inc.  
13224 Fountainhead Plaza  
Hagerstown, MD 21742  
USA

or Your Local JLG Office  
(See addresses on inside of manual cover)

**In USA:**

Toll Free: 877-JLG-SAFE (877-554-7233)

**Outside USA:**

Phone: 240-420-2661  
Fax: 301-745-3713  
E-mail: [ProductSafety@JLG.com](mailto:ProductSafety@JLG.com)

## **REVISION LOG**

Original Issue	A - November 5, 2019
Revision	B - June 26, 2020
Revision	C - August 26, 2020

**SECTION - 1 - SAFETY PRECAUTIONS**

1.1 GENERAL ..... 1-1

1.2 PRE-OPERATION ..... 1-1

    Operator Training and Knowledge ..... 1-1

    Workplace Inspection ..... 1-2

    Machine Inspection ..... 1-3

1.3 OPERATION ..... 1-3

    General ..... 1-3

    Trip and Fall Hazards ..... 1-4

    Electrocution Hazards ..... 1-5

    Tipping Hazards ..... 1-7

    Crushing and Collision Hazards ..... 1-10

1.4 TOWING, LIFTING, AND HAULING ..... 1-11

1.5 MAINTENANCE ..... 1-11

    Maintenance Hazards ..... 1-11

    Battery Hazards ..... 1-12

**SECTION - 2 - USER RESPONSIBILITIES, MACHINE PREPARATION, AND INSPECTION**

2.1 PERSONNEL TRAINING ..... 2-1

    Operator Training ..... 2-1

    Training Supervision ..... 2-1

    Operator Responsibility ..... 2-2

    Machine Familiarization ..... 2-2

2.2 PREPARATION, INSPECTION, AND MAINTENANCE ..... 2-2

    Pre-Start Inspection ..... 2-5

    Walk-Around Inspection ..... 2-7

    Function Check ..... 2-9

SkyGuard Function Test ..... 2-10

2.3 OSCILLATING AXLE LOCKOUT TEST (IF EQUIPPED) .... 2-11

**SECTION - 3 - MACHINE CONTROLS AND INDICATORS**

3.1 GENERAL ..... 3-1

3.2 CONTROLS AND INDICATORS ..... 3-1

    Ground Control Station ..... 3-5

    Platform Station ..... 3-13

    Platform Control Indicator Panel ..... 3-19

**SECTION - 4 - MACHINE OPERATION**

4.1 DESCRIPTION ..... 4-1

4.2 HYDRAULIC SYSTEM WARM UP ..... 4-1

4.3 ENGINE OPERATION ..... 4-2

    Starting Procedure ..... 4-2

    Shutdown Procedure ..... 4-3

    Air Shutoff Valve (ASOV) (If Equipped) ..... 4-3

    Fuel Reserve / Shut-Off System ..... 4-4

4.4 DIESEL PARTICULATE FILTER (IF EQUIPPED) ..... 4-5

    Standstill Cleaning ..... 4-5

    Maintenance Standstill Cleaning Initiation Methods ..... 4-7

    Canceling Maintenance Standstill ..... 4-7

    Unsuccessful Cleaning Event ..... 4-8

    DPF Filter Replacement due to Ash Load ..... 4-8

4.5 BOOM OPERATING CHARACTERISTICS & LIMITATIONS ..... 4-12

    Capacities ..... 4-12

    Envelope Control System ..... 4-12

    Tower Path Control System ..... 4-13

## TABLE OF CONTENTS

Automatic Main Boom Control System .....	4-14	SkyGuard - SkyEye.....	4-28
Slow Down System .....	4-14	SkyGuard Function Table .....	4-28
Controlled Angle .....	4-14	4.15 EMERGENCY TOWING.....	4-29
Swing Speed Proportioning.....	4-15	4.16 SHUT DOWN AND PARK.....	4-30
Platform Load Sensing System (LSS).....	4-15	4.17 LIFTING AND TIE DOWN.....	4-30
Stability .....	4-15	Lifting .....	4-30
4.6 AUXILIARY POWER OPERATION .....	4-19	Tie Down .....	4-31
4.7 CAPACITY SELECT. ....	4-19	4.18 STOWING THE JIB FOR TRANSPORT.....	4-31
4.8 TRAVELING (DRIVING).....	4-21		
Traveling Forward and Reverse .....	4-22	<b>SECTION - 5 - EMERGENCY PROCEDURES</b>	
Traveling on a Grade .....	4-24	5.1 GENERAL .....	5-1
4.9 STEERING.....	4-24	5.2 INCIDENT NOTIFICATION.....	5-1
4.10 EXTENDING THE AXLES .....	4-24	5.3 EMERGENCY OPERATION .....	5-1
4.11 PLATFORM .....	4-24	Operator Unable to Control Machine.....	5-1
Platform Level Adjustment .....	4-24	Platform or Boom Caught Overhead or Boom Move-	
Platform Rotation .....	4-25	ment Prevented by Boom Control System .....	5-2
4.12 BOOM.....	4-25	5.4 EMERGENCY TOWING PROCEDURES.....	5-2
Swinging the Boom .....	4-25	5.5 MACHINE SAFETY SYSTEM OVERRIDE (MSSO)	
Raising and Lowering the Main Boom.....	4-26	(IF EQUIPPED).....	5-3
Telescoping the Main Boom .....	4-26		
Tower Lift .....	4-26	<b>SECTION - 6 - ACCESSORIES</b>	
Swinging the Jib .....	4-26	6.1 FALL ARREST PLATFORM.....	6-3
4.13 FUNCTION SPEED CONTROL .....	4-26	Safety Precautions.....	6-3
4.14 MACHINE SAFETY SYSTEM OVERRIDE (MSSO)		6.2 PIPE RACKS .....	6-4
(IF EQUIPPED).....	4-26	Capacity Specifications (Australia Only) .....	6-4
4.15 SKYGUARD OPERATION .....	4-27	Safety Precautions.....	6-4
SkyGuard .....	4-27	Preparation and Inspection.....	6-5
SkyGuard - SkyLine .....	4-27	Operation.....	6-5

## TABLE OF CONTENTS

6.3	SKYCUTTER™	6-6	Override Button	6-18
	Safety Precautions	6-6	SkySense Coverage Areas	6-19
	Accessory Ratings	6-7	6.9 BOLT-ON EXTERNAL FALL ARREST	6-20
	Generator Output	6-7	Inspection Before Use	6-21
	Preparation and Inspection	6-7		
	Operation	6-7		
6.4	SKYGLAZIER™	6-8	<b>SECTION - 7 - GENERAL SPECIFICATIONS &amp; OPERATOR</b>	
	Capacity Specifications	6-8	<b>MAINTENANCE</b>	
	Safety Precautions	6-9	7.1 INTRODUCTION	7-1
	Preparation and Inspection	6-9	7.2 OPERATING SPECIFICATIONS & PERFORMANCE DATA	7-1
	Operation	6-9	Dimensional Data	7-3
6.5	SKYPOWER™ 7.5 KW AND GENERATOR 4 KW	6-10	Capacities	7-3
	Output	6-10	Tires	7-4
	Safety Precautions	6-11	Engine Data - Deutz 2011	7-4
	Preparation and Inspection	6-11	Engine Data - Caterpillar	7-5
	Operation	6-11	Hydraulic Oil	7-6
6.6	SKYWELDER™	6-11	Major Component Weights	7-9
	Accessory Ratings	6-12	7.3 OPERATOR MAINTENANCE	7-16
	Generator Output	6-12	7.4 TIRES & WHEELS	7-30
	Welding Accessories	6-12	Tire Damage	7-30
	Safety Precautions	6-13	Tire Replacement	7-31
	Preparation and Inspection	6-13	Wheel and Tire Replacement	7-31
	Operation	6-13	Wheel Installation	7-31
6.7	SOFT TOUCH	6-14	7.4 SUPPLEMENTAL INFORMATION ONLY APPLICABLE TO CE	
6.8	SKYSENSE™	6-14	MACHINES	7-33
	Preparation and Inspection	6-15	EC Declaration of Conformity	7-34
	Operation	6-16		
	SkySense Alarm	6-18	<b>SECTION - 8 - INSPECTION AND REPAIR LOG</b>	

## **TABLE OF CONTENTS**

---

## LIST OF FIGURES

2-1.	Basic Nomenclature . . . . .	2-4	6-1.	Bolt-On External Fall Arrest Cable Tension . . . . .	6-21
3-1.	Ground Control Station without MSSO . . . . .	3-2	6-2.	Bolt-On External Fall Arrest System . . . . .	6-22
3-2.	Ground Control Station with MSSO . . . . .	3-3	7-1.	Hydraulic Oil Operation Chart - Sheet 1 of 2 . . . . .	7-10
3-2.	Ground Control Station with MSSO and DPF . . . . .	3-4	7-2.	Hydraulic Oil Operation Chart - Sheet 2 of 2 . . . . .	7-11
3-3.	Ground Control Indicator Panel . . . . .	3-9	7-3.	Engine Operating Temperature Specifications - Caterpillar - Sheet 1 of 2 . . . . .	7-12
3-4.	Platform Control Console . . . . .	3-12	7-4.	Hydraulic System Operating Temperature Specifications - Caterpillar - Sheet 2 of 2 . . . . .	7-13
3-5.	Platform Control Indicator Panel . . . . .	3-18	7-5.	Operator Maintenance and Lubrication Diagram - Deutz 2011/CAT Engines . . . . .	7-14
4-1.	ASOV Reset (Open to Closed Position) . . . . .	4-4	7-6.	Operator Maintenance and Lubrication Diagram - Deutz 2.9 Engine . . . . .	7-15
4-2.	Tower Path vs. Main Boom Angle . . . . .	4-13	7-7.	Hydraulic Return Filter Condition Indicator . . . . .	7-19
4-3.	Position of Least Forward Stability . . . . .	4-16	7-8.	Deutz 2011 Engine Dipstick . . . . .	7-24
4-4.	Position of Least Backward Stability - Sheet 1 of 2 . . . . .	4-17			
4-5.	Position of Least Backward Stability - Sheet 2 of 2 . . . . .	4-18			
4-6.	Range Diagram . . . . .	4-20			
4-7.	Grade and Side Slopes . . . . .	4-23			
4-8.	Traveling on a Grade . . . . .	4-24			
4-9.	Drive Disconnect Hub . . . . .	4-29			
4-10.	Lifting and Tie Down Chart . . . . .	4-32			
4-11.	Decal Location Sheet 1 of 5 . . . . .	4-33			
4-12.	Decal Location Sheet 2 of 5 . . . . .	4-34			
4-13.	Decal Location Sheet 3 of 5 . . . . .	4-35			
4-14.	Decal Location Sheet 4 of 5 . . . . .	4-36			
4-15.	Decal Location Sheet 5 of 5 . . . . .	4-37			
4-16.	Decal Location - CE Only - Sheet 1 of 5 . . . . .	4-41			
4-17.	Decal Location - CE Only - Sheet 2 of 5 . . . . .	4-42			
4-18.	Decal Location - CE Only - Sheet 3 of 5 . . . . .	4-43			
4-19.	Decal Location - CE Only - Sheet 4 of 5 . . . . .	4-44			
4-20.	Decal Location - CE Only - Sheet 5 of 5 . . . . .	4-45			
6-1.	SkySense Platform Panel Indicators . . . . .	6-17			

## ***LIST OF FIGURES***

---



---

1-1	Minimum Approach Distances (M.A.D.)	1-6
1-2	Beaufort Scale (For Reference Only)	1-9
2-1	Inspection and Maintenance Table	2-3
4-1	Ash Load DPF Filter Replacement	4-9
4-2	Decal Legend	4-38
4-3	Decal Legend - CE Only	4-46
6-1	Available Accessories	6-1
6-2	Options/Accessories Relationship Table	6-2
7-1	Operating Specifications	7-1
7-2	Dimensional Data	7-3
7-3	Capacities	7-3
7-4	Tire Specifications	7-4
7-5	Deutz TD2011L4 Specifications	7-4
7-6	Deutz TCD2.9L4 Specifications	7-5
7-7	Caterpillar 3.4T	7-5
7-8	Hydraulic Oil Specifications	7-6
7-9	Mobilfluid 424 Specs	7-6
7-10	Mobil DTE 10 Excel 32 Specs	7-7
7-11	UCon Hydrolube HP-5046	7-7
7-12	Exxon Univis HVI 26 Specs	7-8
7-13	Mobil EAL H 46 Specs	7-8
7-14	Mobil EAL 46 Specs	7-9
7-15	Component Weights	7-9
7-16	Lubrication Specifications	7-16
7-17	Wheel Torque Chart	7-32
8-1	Inspection and Repair Log	8-1

***LIST OF TABLES***

---

## SECTION 1. SAFETY PRECAUTIONS

### 1.1 GENERAL

This section outlines the necessary precautions for proper and safe machine usage and maintenance. It is mandatory that a daily routine is established based on the content of this manual to promote proper machine usage. A maintenance program, using the information provided in this manual and the Service and Maintenance Manual, must also be established by a qualified person and must be followed to ensure that the machine is safe to operate.

The owner/user/operator/lessor/lessee of the machine must not accept operating responsibility until this manual has been read, training is accomplished, and operation of the machine has been completed under the supervision of an experienced and qualified operator.

This section contains the responsibilities of the owner, user, operator, lessor, and lessee concerning safety, training, inspection, maintenance, application, and operation. If there are any questions with regard to safety, training, inspection, maintenance, application, and operation, please contact JLG Industries, Inc. ("JLG").

### **⚠ WARNING**

**FAILURE TO COMPLY WITH THE SAFETY PRECAUTIONS LISTED IN THIS MANUAL COULD RESULT IN MACHINE DAMAGE, PROPERTY DAMAGE, PERSONAL INJURY OR DEATH.**

### 1.2 PRE-OPERATION

#### Operator Training and Knowledge

- Read, understand, and study the Operation and Safety Manual in its entirety before operating the machine. For clarification, questions, or additional information regarding any portions of this manual, contact JLG Industries, Inc.

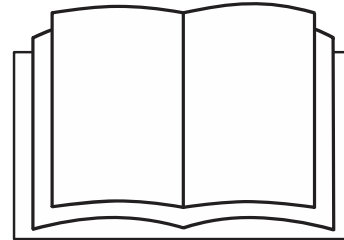

## **SECTION 1 - SAFETY PRECAUTIONS**

---

- Only personnel who have received proper training regarding the inspection, application and operation of MEWPs (including recognition and avoiding hazards associated with their operation) shall be authorized to operate a MEWP.
- Only properly trained personnel who have received unit-specific familiarization shall operate a MEWP. The user shall determine if personnel are qualified to operate the MEWP prior to operation.
- Read, understand, and obey all DANGERS, WARNINGS, CAUTIONS, and operating instructions on the machine and in this manual.
- Ensure that the machine is to be used in a manner which is within the scope of its intended application as determined by JLG.
- All operating personnel must have a thorough understanding of the intended purpose and function of the MEWP controls, including platform, ground, and emergency descent controls.
- Read, understand, and obey all applicable employer, local, and governmental regulations as they pertain to your utilization and application of the machine.

### **Workplace Inspection**

- Precautions to avoid all hazards in the work area must be taken by the user before and during operation of the machine.
- Do not operate or raise the platform from a position on trucks, trailers, railway cars, floating vessels, scaffolds or other equipment unless the application is approved in writing by JLG.
- Before operation, check work area for overhead hazards such as electric lines, bridge cranes, and other potential overhead obstructions.
- Check operating surfaces for holes, bumps, drop-offs, obstructions, debris, concealed holes, and other potential hazards.
- Check the work area for hazardous locations. Do not operate the machine in hazardous environments unless approved for that purpose by JLG.
- Ensure that the ground conditions are adequate to support the maximum tire load indicated on the tire load decals located on the chassis adjacent to each wheel. Do not travel on unsupported surfaces.

## **Machine Inspection**

- Do not operate this machine until the inspections and functional checks as specified in Section 2 of this manual have been performed.
- Do not operate this machine until it has been serviced and maintained according to the maintenance and inspection requirements as specified in the machine's Service and Maintenance Manual.
- Ensure all safety devices are operating properly. Modification of these devices is a safety violation.

### **WARNING**

#### **MODIFICATION OR ALTERATION OF A MEWP SHALL BE MADE ONLY WITH PRIOR WRITTEN PERMISSION FROM THE MANUFACTURER.**

- Do not operate any machine on which the safety or instruction placards or decals are missing or illegible.
- Check the machine for modifications to original components. Ensure that any modifications have been approved by JLG.
- Avoid accumulation of debris on platform floor. Keep mud, oil, grease, and other slippery substances from footwear and platform floor.

## **1.3 OPERATION**

### **General**

- Machine operation requires your full attention. Bring the machine to a full stop before using any device, i.e. cell phones, two-way radios, etc. that will distract your attention from safely operating the machine.
- Do not use the machine for any purpose other than positioning personnel, their tools, and equipment.
- Before operation, the user must be familiar with the machine capabilities and operating characteristics of all functions.
- Never operate a malfunctioning machine. If a malfunction occurs, shut down the machine. Remove the unit from service and notify the proper authorities.
- Do not remove, modify, or disable any safety devices.
- Never slam a control switch or lever through neutral to an opposite direction. Always return switch to neutral and stop before moving the switch to the next function. Operate controls with slow and even pressure.
- Do not allow personnel to tamper with or operate the machine from the ground with personnel in the platform, except in an emergency.

## SECTION 1 - SAFETY PRECAUTIONS

---

- Do not carry materials directly on platform railing unless approved by JLG.
- When two or more persons are in the platform, the operator shall be responsible for all machine operations.
- Always ensure that power tools are properly stowed and never left hanging by their cord from the platform work area.
- When driving, always position boom over rear axle in line with the direction of travel. Remember, if boom is over the front axle, steer and drive functions will be reversed.
- Do not assist a stuck or disabled machine by pushing or pulling except by pulling at the chassis tie-down lugs.
- Fully lower platform and shut off all power before leaving machine.
- Remove all rings, watches, and jewelry when operating machine. Do not wear loose fitting clothing or long hair unrestrained which may become caught or entangled in equipment.
- Persons under the influence of drugs or alcohol or who are subject to seizures, dizziness or loss of physical control must not operate this machine.

- Hydraulic cylinders are subject to thermal expansion and contraction. This may result in changes to the platform position while the machine is stationary. Factors affecting thermal movement can include the length of time the machine will remain stationary, hydraulic oil temperature, ambient air temperature, and boom and platform position.

### **Trip and Fall Hazards**

- Prior to operation, ensure all gates are closed and fastened in their proper position.
- During operation, occupants in the platform must wear a full body harness with a lanyard attached to an authorized lanyard anchorage point. Attach only one (1) lanyard per lanyard anchorage point.

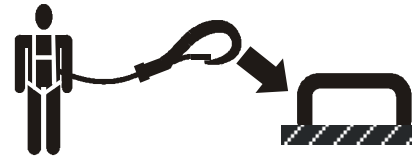

- Enter and exit only through gate area. Use extreme caution when entering or leaving platform. Ensure that the platform assembly is fully lowered. Face the platform when entering or leaving the platform. Always maintain three points of contact with the machine, using two hands and one foot or two feet and one hand at all times during entry and exit.

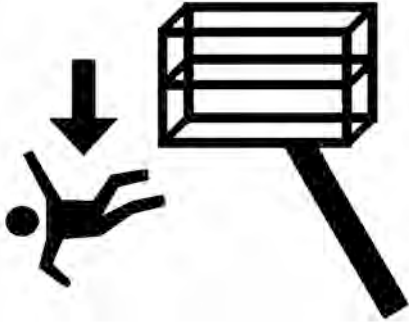

- Keep both feet firmly positioned on the platform floor at all times. Never position ladders, boxes, steps, planks, or similar items on unit to provide additional reach for any purpose.
- Keep oil, mud, and slippery substances cleaned from footwear and the platform floor.

### Electrocution Hazards

- This machine is not insulated and does not provide protection from contact or proximity to electrical current.



- It is not recommended to use the machine during lightning. To prevent injury or machine damage if lightning occurs during operation, lower the boom and shut down the machine in a safe and secure location.

## SECTION 1 - SAFETY PRECAUTIONS

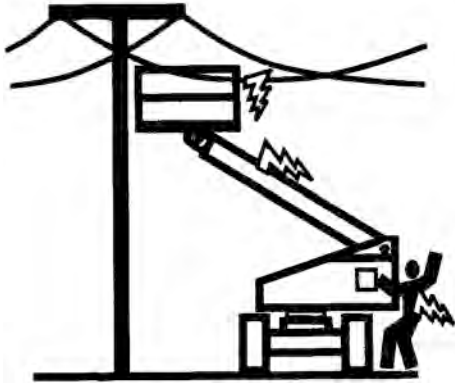

- Maintain distance from electrical lines, apparatus, or any energized (exposed or insulated) parts according to the Minimum Approach Distance (MAD) as shown in Table 1-1.
- Allow for machine movement and electrical line swaying.

**Table 1-1. Minimum Approach Distances (M.A.D.)**

<b>Voltage Range (Phase to Phase)</b>	<b>MINIMUM APPROACH DISTANCE in Feet (Meters)</b>
0 to 50 KV	10 (3)
Over 50KV to 200 KV	15 (5)
Over 200 KV to 350 KV	20 (6)
Over 350 KV to 500 KV	25 (8)
Over 500 KV to 750 KV	35 (11)
Over 750 KV to 1000 KV	45 (14)

**NOTE:** *This requirement shall apply except where employer, local or governmental regulations are more stringent.*

- Maintain a clearance of at least 10 ft. (3m) between any part of the machine and its occupants, their tools, and their equipment from any electrical line or apparatus carrying up to 50,000 volts. One foot additional clearance is required for every additional 30,000 volts or less.



- The minimum approach distance may be reduced if insulating barriers are installed to prevent contact, and the barriers are rated for the voltage of the line being guarded. These barriers shall not be part of (or attached to) the machine. The minimum approach distance shall be reduced to a distance within the designed working dimensions of the insulating barrier. This determination shall be made by a qualified person with respect to electrical transmission and distribution in accordance with the employer, local, or governmental requirements for work practices near energized equipment.

**⚠ DANGER**

**DO NOT MANEUVER MACHINE OR PERSONNEL INSIDE PROHIBITED ZONE (MAD). ASSUME ALL ELECTRICAL PARTS AND WIRING ARE ENERGIZED UNLESS KNOWN OTHERWISE.**

**Tipping Hazards**

- Ensure that the ground conditions are adequate to support the maximum tire load indicated on the tire load decals located on the chassis adjacent to each wheel. Do not travel on unsupported surfaces.
- The user must be familiar with the operating surface before driving. Do not exceed the allowable sideslope and grade while driving.

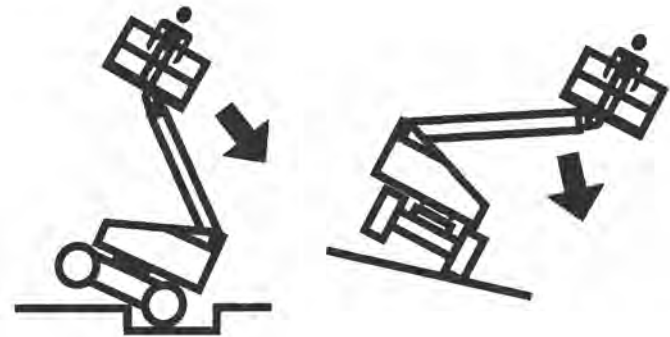

- Do not elevate platform or drive with platform elevated while on or near a sloping, uneven, or soft surface. Ensure machine is positioned on a smooth, firm surface within the limits of the maximum operating slope before elevating platform or driving with the platform in the elevated position.

## **SECTION 1 - SAFETY PRECAUTIONS**

---

- Before driving on floors, bridges, trucks, and other surfaces, check allowable capacity of the surfaces.
- Never exceed the maximum work load as specified on the platform. Keep all loads within the confines of the platform, unless authorized by JLG.
- Keep the chassis of the machine a minimum of 2 ft. (0.6m) from holes, bumps, drop-offs, obstructions, debris, concealed holes, and other potential hazards at the ground level.
- Do not push or pull any object with the boom.
- Never attempt to use the machine as a crane. Do not tie-off machine to any adjacent structure. Never attach wire, cable, or any similar items to platform.
- If boom assembly or platform is in a position that one or more wheels are off the ground, all persons must be removed before attempting to stabilize the machine. Use cranes, forklift trucks, or other appropriate equipment to stabilize machine.
- Do not operate the machine when wind conditions, including gusts, exceed specifications shown in section 7-2 of this manual or as shown on the capacity placard of the platform billboard. Factors affecting wind speed are; platform elevation, surrounding structures, local weather events, and approaching storms.
- Wind speed can be significantly greater at height than at ground level.
- Wind speed can change rapidly. Always consider approaching weather events, the time required to lower the platform, and methods to monitor current and potential wind conditions.
- Do not cover or increase surface area of the platform or the load. Do not carry large surface area items in the platform when operating outdoors. The addition of such items increases the exposed wind area of the machine. Increased areas exposed to wind will decrease stability.
- Do not increase the platform size with unauthorized modifications or attachments.

**NOTICE**

**DO NOT OPERATE THE MACHINE WHEN WIND CONDITIONS EXCEED SPECIFICATIONS SHOWN IN SECTION 7.2 OR AS SHOWN ON THE CAPACITY PLACARD ON THE PLATFORM BILLBOARD.**

**Table 1-2. Beaufort Scale (For Reference Only)**

Beaufort Number	Wind Speed		Description	Land Conditions
	mph	m/s		
0	0	0-0.2	Calm	Calm. Smoke rises vertically
1	1-3	0.3-1.5	Light air	Wind motion visible in smoke
2	4-7	1.6-3.3	Light breeze	Wind felt on exposed skin. Leaves rustle
3	8-12	3.4-5.4	Gentle breeze	Leaves and smaller twigs in constant motion
4	13-18	5.5-7.9	Moderate breeze	Dust and loose paper raised. Small branches begin to move.
5	19-24	8.0-10.7	Fresh breeze	Smaller trees sway.
6	25-31	10.8-13.8	Strong breeze	Large branches in motion. Flags waving near horizontal. Umbrella use becomes difficult.
7	32-38	13.9-17.1	Near Gale/Moderate Gale	Whole trees in motion. Effort needed to walk against the wind.
8	39-46	17.2-20.7	Fresh Gale	Twigs broken from trees. Cars veer on road.
9	47-54	20.8-24.4	Strong Gale	Light structure damage.

## SECTION 1 - SAFETY PRECAUTIONS

---

### Crushing and Collision Hazards

- Approved head gear must be worn by all operating and ground personnel.
- Watch for obstructions around machine and overhead when driving. Check clearances above, on sides, and bottom of platform during all operations.



- During operation, keep all body parts inside platform railing.
- Use the boom functions, not the drive function, to position the platform close to obstacles.
- Always post a lookout when driving in areas where vision is obstructed.

- Keep non-operating personnel at least 6 ft. (1.8m) away from machine during all operations.
- Under all travel conditions, the operator must limit travel speed according to conditions of ground surface, congestion, visibility, slope, location of personnel, and other factors.
- Be aware of stopping distances in all drive speeds. When driving in high speed, reduce drive speed before stopping. Travel grades in low speed only.
- Do not use high speed drive in restricted or close quarters or when driving in reverse.
- Exercise extreme caution at all times to prevent obstacles from striking or interfering with operating controls and persons in the platform.
- Ensure that operators of other overhead and floor level machines are aware of the MEWP's presence. Disconnect power to overhead cranes.
- Do not operate over ground personnel. Warn personnel not to work, stand, or walk under a raised boom or platform. Position barricades on floor if necessary.

## **1.4 TOWING, LIFTING, AND HAULING**

- Never allow personnel in platform while towing, lifting, or hauling.
- This machine should not be towed, except in the event of emergency, malfunction, power failure, or loading/unloading. Refer to the Emergency Procedures section of this manual for emergency towing procedures.
- Ensure boom is in the stowed position and, if equipped, the turntable locked prior to towing, lifting or hauling. The platform must be completely empty of tools.
- When lifting machine, lift only at designated areas of the machine. Lift the unit with equipment of adequate capacity.
- Refer to the Machine Operation section of this manual for lifting information.

## **1.5 MAINTENANCE**

This sub-section contains general safety precautions which must be observed during maintenance of this machine. Additional precautions to be observed during machine maintenance are inserted at the appropriate points in this manual and in the Service and Maintenance Manual. It is of utmost importance that maintenance personnel pay strict attention to these precautions to avoid possible injury to personnel or damage to the machine or property. A maintenance program must be established by a qualified person and must be followed to ensure that the machine is safe.

### **Maintenance Hazards**

- Shut off power to all controls and ensure that all moving parts are secured from inadvertent motion prior to performing any adjustments or repairs.
- Never work under an elevated platform until it has been fully lowered to the full down position, if possible, or otherwise supported and restrained from movement with appropriate safety props, blocking, or overhead supports.
- DO NOT attempt to repair or tighten any hydraulic hoses or fittings while the machine is powered on or when the hydraulic system is under pressure.
- Always relieve hydraulic pressure from all hydraulic circuits before loosening or removing hydraulic components.

## SECTION 1 - SAFETY PRECAUTIONS

---

- DO NOT use your hand to check for leaks. Use a piece of cardboard or paper to search for leaks. Wear gloves to help protect hands from spraying fluid.



- Use only replacement parts or components that are approved by JLG. To be considered approved, replacement parts or components must be identical or equivalent to original parts or components.
- Never attempt to move heavy parts without the aid of a mechanical device. Do not allow heavy objects to rest in an unstable position. Ensure adequate support is provided when raising components of the machine.
- Do not use machine as a ground for welding.
- When performing welding or metal cutting operations, precautions must be taken to protect the chassis from direct exposure to weld and metal cutting spatter.
- Do not refuel the machine with the engine running.
- Use only approved non-flammable cleaning solvents.
- Do not replace items critical to stability, such as batteries or solid tires, with items of different weight or specification. Do not modify the MEWP in any way to affect stability.
- Refer to the Service and Maintenance Manual for the weights of critical stability items.

### **⚠ WARNING**

**MODIFICATION OR ALTERATION OF A MEWP SHALL BE MADE ONLY WITH PRIOR WRITTEN PERMISSION FROM THE MANUFACTURER.**

### **Battery Hazards**

- Always disconnect batteries when servicing electrical components or when performing welding on the machine.
- Do not allow smoking, open flame, or sparks near battery during charging or servicing.
- Do not contact tools or other metal objects across the battery terminals.
- Always wear hand, eye, and face protection when servicing batteries. Ensure that battery acid does not come in contact with skin or clothing.

### **⚠ CAUTION**

**BATTERY FLUID IS HIGHLY CORROSIVE. AVOID CONTACT WITH SKIN AND CLOTHING AT ALL TIMES. IMMEDIATELY RINSE ANY CONTACTED AREA WITH CLEAN WATER AND SEEK MEDICAL ATTENTION.**

- Charge batteries only in a well ventilated area.
- Avoid overfilling the battery fluid level. Add distilled water to batteries only after the batteries are fully charged.

## **SECTION 2. USER RESPONSIBILITIES, MACHINE PREPARATION, AND INSPECTION**

### **2.1 PERSONNEL TRAINING**

The Mobile Elevating Work Platform (MEWP) is a personnel handling device; so it is necessary that it be operated and maintained only by trained personnel.

#### **Operator Training**

Operator training must cover:

- 1.** Reading and understanding the Operation and Safety Manual.
- 2.** Thorough understanding of the intended purpose and function of the MEWP controls, including platform, ground, and emergency descent controls.
- 3.** Control labels, instructions, and warnings on the machine.
- 4.** Applicable regulations, standards, and safety rules.
- 5.** Use of approved fall protection equipment.
- 6.** Enough knowledge of the mechanical operation of the machine to recognize a malfunction or potential malfunction.

- 7.** The safest means to operate the machine where overhead obstructions, other moving equipment, and obstacles, depressions, holes, and drop-offs exist.
- 8.** Means to avoid the hazards of unprotected electrical conductors.
- 9.** Selection of the appropriate MEWP and available options for the work to be performed considering specific job requirements, with involvement from the MEWP owner, user, and/or supervisor.
- 10.** The responsibility of the operator to ensure all platform occupants have a basic level of knowledge to work safely on the MEWP, and to inform them of applicable regulations, standards, and safety rules.
- 11.** The requirement for familiarization in addition to training.

#### **Training Supervision**

Training must be delivered by a qualified person in an open area, free of hazards until the trainee has demonstrated the ability to safely control and operate the machine.

## **SECTION 2 - USER RESPONSIBILITIES, MACHINE PREPARATION, AND INSPECTION**

---

### **Operator Responsibility**

The operator must be instructed that they have the responsibility and authority to shut down the machine in case of a malfunction or other unsafe condition of either the machine or the job site.

### **Machine Familiarization**

**NOTE:** *Responsibilities for familiarization may vary by region.*

Only properly trained personnel who have received unit-specific familiarization shall operate a MEWP. The user shall determine if personnel are qualified to operate the MEWP prior to operation. The user shall ensure that after familiarization, the operator operates the MEWP for a sufficient period of time to achieve proficiency. When authorized by the user, self-familiarization can be achieved, if authorized, by a properly trained operator reading, understanding and following the manufacturer's operator's manual.

Prior to users authorization of an operator to use a specific model of MEWP, the user shall ensure the operator is familiarized on the following:

1. Location of the manual storage compartment and the requirement to ensure the required manual(s) are present on the MEWP;
2. Purpose and function of the machine controls and indicators at the platform and ground control stations;

3. Purpose, location, and function of the emergency controls;
4. Operating characteristics and limitations;
5. Features and devices;
6. Accessories and optional equipment.

### **2.2 PREPARATION, INSPECTION, AND MAINTENANCE**

The following table covers machine inspections and maintenance required by JLG Industries, Inc. Consult local regulations for further requirements for MEWPs. The frequency of inspections and maintenance must be increased as necessary when the machine is used in a harsh or hostile environment, if the machine is used with increased frequency, or if the machine is used in a severe manner.



## SECTION 2 - USER RESPONSIBILITIES, MACHINE PREPARATION, AND INSPECTION

**Table 2-1. Inspection and Maintenance Table**

Type	Frequency	Primary Responsibility	Service Qualification	Reference
Pre-Start Inspection	Before using each day; or whenever there's an Operator change.	User or Operator	User or Operator	Operator and Safety Manual
Pre-Delivery Inspection (See Note)	Before each sale, lease, or rental delivery.	Owner, Dealer, or User	Qualified JLG Mechanic	Service and Maintenance Manual and applicable JLG inspection form
Frequent Inspection (See Note)	In service for 3 months or 150 hours, whichever comes first; or Out of service for a period of more than 3 months; or Purchased used.	Owner, Dealer, or User	Qualified JLG Mechanic	Service and Maintenance Manual and applicable JLG inspection form
Annual Machine Inspection (See Note)	Annually, no later than 13 months from the date of prior inspection.	Owner, Dealer, or User	Factory Trained Service Technician (Recommended)	Service and Maintenance Manual and applicable JLG inspection form
Preventative Maintenance	At intervals as specified in the Service and Maintenance Manual.	Owner, Dealer, or User	Qualified JLG Mechanic	Service and Maintenance Manual

**NOTE:** Inspection forms are available from JLG. Use the Service and Maintenance Manual to perform inspections.

### NOTICE

**JLG INDUSTRIES, INC. RECOGNIZES A FACTORY TRAINED SERVICE TECHNICIAN AS A PERSON WHO HAS SUCCESSFULLY COMPLETED THE JLG SERVICE TRAINING SCHOOL FOR THE SPECIFIC JLG PRODUCT MODEL.**

## SECTION 2 - USER RESPONSIBILITIES, MACHINE PREPARATION, AND INSPECTION

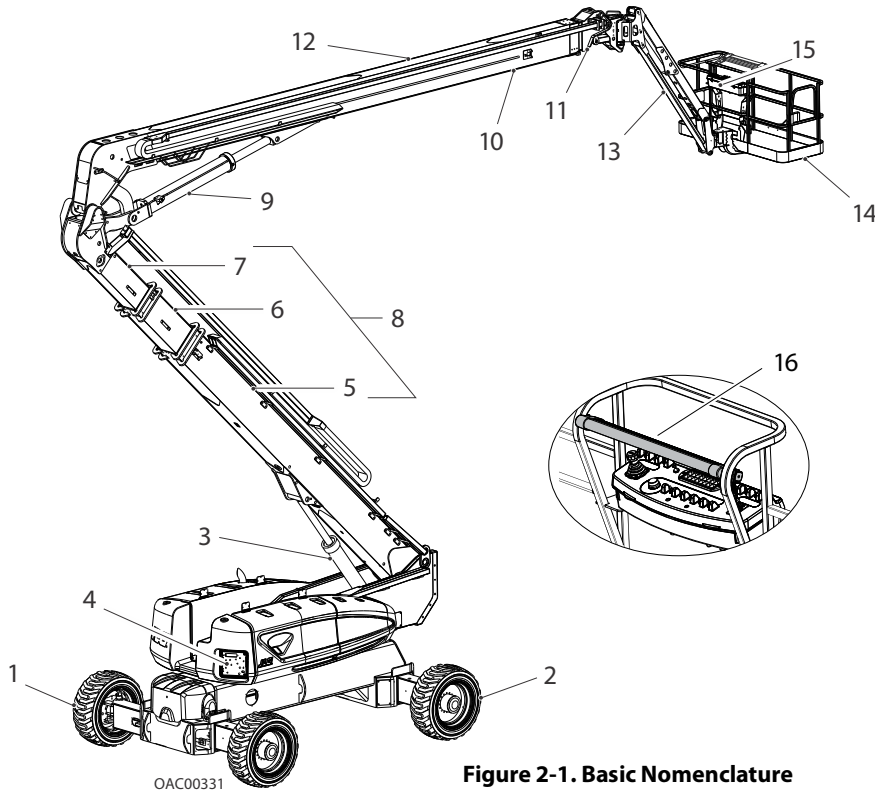

1. Front Drive\Steer Wheels
2. Rear Drive\Steer Wheels
3. Tower Lift Cylinder
4. Ground Console
5. Tower Base Boom Section
6. Tower Mid Boom Section
7. Tower Fly Boom Section
8. Tower Boom Assembly
9. Main Lift Cylinder
10. Main Base Boom Section
11. Main Boom Fly Section
12. Main Boom Assembly
13. Jib
14. Platform
15. Platform Console
16. SkyGuard

Figure 2-1. Basic Nomenclature

OAC00331

### Pre-Start Inspection

The Pre-Start Inspection should include each of the following:

1. **Cleanliness** – Check all surfaces for leakage (oil, fuel, or battery fluid) or foreign objects. Report any leakage to the proper maintenance personnel.
2. **Structure** – Inspect the machine structure for dents, damage, weld or parent metal cracks or other discrepancies.

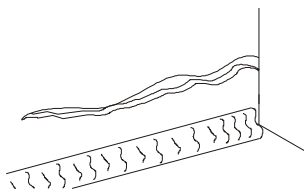

Parent Metal Crack

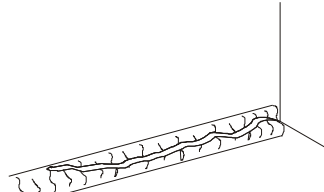

Weld Crack

3. **Decals and Placards** – Check all for cleanliness and legibility. Make sure none of the decals and placards are missing. Make sure all illegible decals and placards are cleaned or replaced.
4. **Operation and Safety Manuals** – Make sure a copy of the Operation and Safety Manual, AEM Safety Manual (ANSI markets only), and ANSI Manual of Responsibilities (ANSI markets only) is enclosed in the weather resistant storage container.

5. **Walk-Around Inspection** – Perform as instructed.
6. **Battery** – Charge as required.
7. **Fuel (Combustion Engine Powered Machines)** – Add the proper fuel as necessary.
8. **Engine Oil Supply** – Ensure the engine oil level is at the Full mark on the dipstick and the filler cap is secure.
9. **Hydraulic Oil** – Check the hydraulic oil level. Ensure hydraulic oil is added as required.
10. **Accessories/Attachments** – Refer to the Accessories section in this manual or the accessory installed upon the machine for specific inspection, operation, and maintenance instructions.
11. **Function Check** – Once the Walk-Around Inspection is complete, perform a functional check of all systems in an area free of overhead and ground level obstructions. Refer to Section 4 for more specific operating instructions.
12. **Boom Control System Check** - Perform a check of the boom control system as specified in this section.

## **SECTION 2 - USER RESPONSIBILITIES, MACHINE PREPARATION, AND INSPECTION**

---

- 13. Platform Gate** - Keep gate and surrounding area clean and unobstructed. Verify the gate closes properly and is not bent or damaged. Keep gate closed at all times except when entering/exiting the platform and loading/unloading materials.
- 14. Lanyard Attach Points** - During operation, occupants in the platform must wear a full body harness with a lanyard attached to an authorized lanyard anchorage point. Attach only one (1) lanyard per lanyard anchorage point.

### **WARNING**

**IF THE MACHINE DOES NOT OPERATE PROPERLY, TURN OFF THE MACHINE IMMEDIATELY! REPORT THE PROBLEM TO THE PROPER MAINTENANCE PERSONNEL. DO NOT OPERATE THE MACHINE UNTIL IT IS DECLARED SAFE FOR OPERATION.**

Walk-Around Inspection

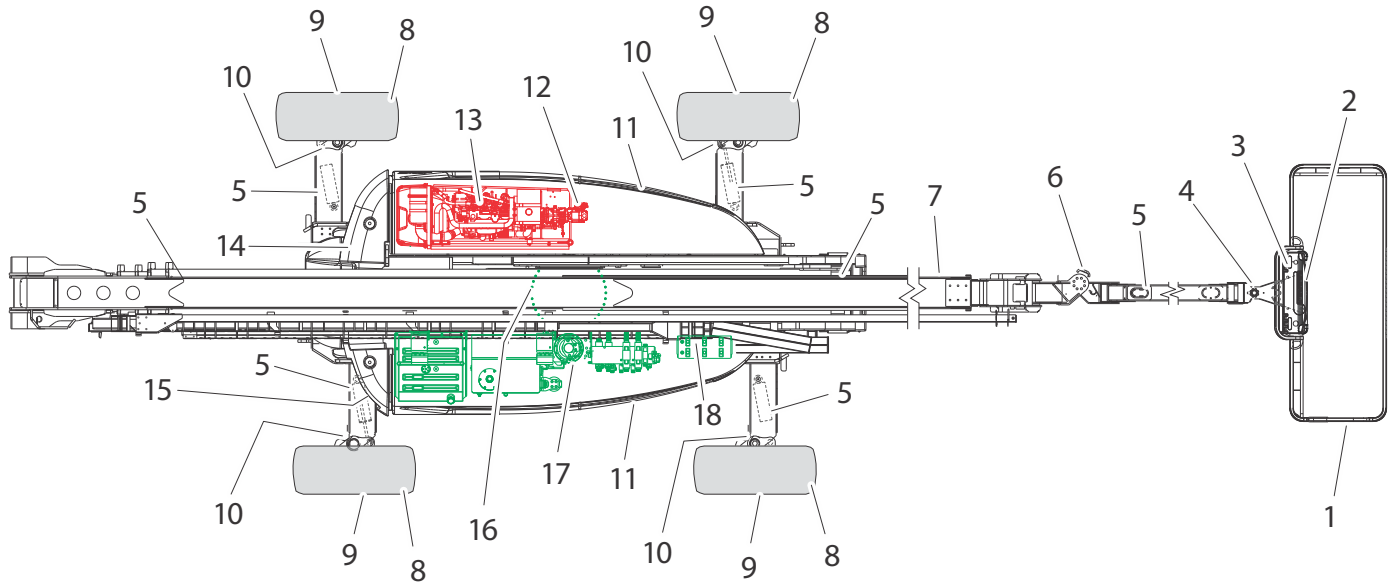

## SECTION 2 - USER RESPONSIBILITIES, MACHINE PREPARATION, AND INSPECTION

---

### Walk-Around Inspection

Begin the Walk-Around Inspection at Item 1, as noted on the diagram. Continue checking each item in sequence for the conditions listed in the following checklist.

#### **WARNING**

**TO AVOID POSSIBLE INJURY, BE SURE MACHINE POWER IS OFF. DO NOT OPERATE MACHINE UNTIL ALL MALFUNCTIONS HAVE BEEN CORRECTED.**

#### **NOTICE**

**DO NOT OVERLOOK VISUAL INSPECTION OF CHASSIS UNDERSIDE. CHECKING THIS AREA MAY RESULT IN DISCOVERY OF CONDITIONS WHICH COULD CAUSE EXTENSIVE MACHINE DAMAGE.**

***INSPECTION NOTE:** On all components, make sure there are no loose or missing parts, that they are securely fastened, and no visible damage, leaks or excessive wear exists in addition to any other criteria mentioned.*

- 1. Platform Assembly and Gate** - Footswitch works properly, not modified, disabled or blocked. Latch and hinges in working condition.
- 2. SkyGuard** - See Inspection Note.
- 3. Platform Control Console** - Switches and levers return to neutral when activated and released, decals/placards secure and legible, control markings legible.
- 4. Platform Rotator** - See Inspection Note.
- 5. All Hydraulic Cylinders** - No visible damage; pivot pins and hydraulic hoses undamaged, not leaking.
- 6. Jib Rotator** - See Inspection Note.
- 7. Boom Sections/Uprights/Turntable** - See Inspection Note.
- 8. Wheel/Tire Assemblies** - Properly secured, no missing lug nuts. Inspect for worn tread, cuts, tears or other discrepancies. Inspect wheels for damage and corrosion.
- 9. Drive Motor, Brake, and Hub** - No evidence of leakage.
- 10. Steering Spindles and Sensors** - See Inspection Note.
- 11. Hood Assemblies** - See Inspection Note.
- 12. Main Hydraulic Pump** - See Inspection Note.
- 13. Air Shutoff Valve (ASOV) (If Equipped)** - See Inspection Note.
- 14. Counterweight** - See Inspection Note.
- 15. Ground Control Console** - Switches and levers return to neutral when activated and released, decals/placards secure and legible, control markings legible.

16. **Turntable Bearing** - Evidence of proper lubrication. No evidence of loose bolts or looseness between bearing and machine.
17. **Swing Drive** - No evidence of damage.
18. **Auxiliary Hydraulic Pump** - See Inspection Note.

### Function Check

Perform the Function Check as follows:

1. From the ground control panel with no load in the platform:
  - a. Ensure that all machine functions are disabled when the Emergency Stop Button is pushed in.
  - b. Ensure all functions stop when the function switch is released.
  - c. Operate all functions and check all limiting and cut-out switches to ensure proper operation.
  - d. Check auxiliary power and ensure proper operation.
  - e. Raise main boom approximately horizontal, then extend and retract boom sections. All boom sections should extend/retract together at the same rate of speed. Any difference would indicate delayed movement and loose wire ropes.

### WARNING

**IF DELAYED MOVEMENT IS DETECTED IN WIRE ROPE OPERATION, LOWER PLATFORM TO STOWED POSITION, SHUT DOWN MACHINE, AND HAVE WIRE ROPES INSPECTED/SERVICED BY A QUALIFIED JLG MECHANIC. LOOSE OR MISADJUSTED WIRE ROPES COULD RESULT IN SERIOUS INJURY OR DEATH.**

2. Check the Boom Control System. Refer to Boom Control System Check Procedure below.
3. From the platform control console:
  - a. Ensure the control console is firmly secured in the proper location.
  - b. Check all guards protecting the switches or locks are in place.
  - c. Ensure all machine functions are disabled when the Emergency Stop Button is pushed in.
  - d. Ensure all machine functions stop when the footswitch is released.
  - e. Operate all functions and check all limiting and cut-out switches to ensure proper operation.

## SECTION 2 - USER RESPONSIBILITIES, MACHINE PREPARATION, AND INSPECTION

---

4. With the platform in the (stowed) position:
    - a. Drive the machine on a grade, not to exceed the rated gradeability, and stop to ensure the brakes hold.
    - b. Check that the tilt indicator is illuminated to ensure proper operation.
  5. Swing the boom over either rear corner of the machine and ensure that the Drive Orientation indicator illuminates and that the Drive Orientation Override switch must be used for the drive function to operate.
  6. Ensure machine is positioned on a smooth, firm surface with axles fully extended and drive machine with boom elevated beyond 6 degrees horizontal. Ensure drive speed is reduced while operating.
- b. **SkyGuard - SkyLine** - Press cable to break magnetic connection between the cable and right bracket.
  - c. **SkyGuard - SkyEye** - Put arm or hand in path of sensor beam.
3. Once the sensor has been activated, verify the following conditions:
    - a. Telescope out function stops and telescope in function operates for a short duration.
    - b. The horn sounds.
    - c. If equipped with a SkyGuard beacon, the beacon illuminates.

**NOTE:** *If SkyGuard is enabled with the Soft Touch system, functions will cut out instead of reversing.*

4. Disengage the SkyGuard sensor, release controls, then recycle the footswitch. Ensure normal operation is available.

**NOTE:** *On machines equipped with SkyLine, reattach magnetic end of the cable to the bracket.*

If SkyGuard remains activated after function reversal or cutout, depress and hold the SkyGuard Override Switch to allow normal use of machine functions until the sensor is disengaged.

### SkyGuard Function Test

**NOTE:** *Refer to Section 4.14 for additional information on SkyGuard operation.*

From the Platform Console in an area free from obstructions:

1. Operate the telescope out function.
2. Activate the SkyGuard sensor:
  - a. **SkyGuard** - Apply approximately 50 lb (222 Nm) of force to yellow bar.



### 2.3 OSCILLATING AXLE LOCKOUT TEST (IF EQUIPPED)

The front axles will oscillate when the boom is in the transport position.

#### **NOTICE**

**LOCKOUT SYSTEM TEST MUST BE PERFORMED QUARTERLY, ANY TIME A SYSTEM COMPONENT IS REPLACED, OR WHEN IMPROPER SYSTEM OPERATION IS SUSPECTED.**

**NOTE:** *Ensure the axles are extended and the boom is fully retracted, lowered, and centered between the rear wheels prior to beginning lockout cylinder test.*

1. Place a 6 inch (15.2 cm) high block with ascension ramp in front of left front wheel.
2. From platform control station, start engine.
3. Place the Drive control lever to the forward position and carefully drive machine up ascension ramp until left front wheel is on top of block.
4. Carefully extend the boom just enough to get it out of the transport position.
5. With boom in this position, place Drive control lever to Reverse and carefully drive machine off of block and ramp.

6. Have an assistant check to see that left front or right rear wheel remains elevated in position off of the ground.
7. Carefully return the boom to the transport position. When boom reaches the transport position, carefully activate Drive to release cylinders. The lockout cylinders should release and allow the wheel to rest on ground.
8. Repeat the procedure for the right oscillation cylinder checking to see that the right front or left rear wheel remains elevated in position off of the ground.
9. If lockout cylinders do not function properly, have qualified personnel correct the malfunction prior to any further operation.

***SECTION 2 - USER RESPONSIBILITIES, MACHINE PREPARATION, AND INSPECTION***

---

## SECTION 3. MACHINE CONTROLS AND INDICATORS

### 3.1 GENERAL

#### **NOTICE**

**THE MANUFACTURER HAS NO DIRECT CONTROL OVER MACHINE APPLICATION AND OPERATION. THE USER AND OPERATOR ARE RESPONSIBLE FOR CONFORMING WITH GOOD SAFETY PRACTICES.**

This section provides the necessary information needed to understand control functions.

### 3.2 CONTROLS AND INDICATORS

**NOTE:** *The indicator panels use different shaped symbols to alert the operator to different types of operational situations that could arise. The meaning of those symbols are explained below.*



*Indicates a potentially hazardous situation, which if not corrected, could result in serious injury or death. This indicator will be red.*



*Indicates an abnormal operating condition, which if not corrected, may result in machine interruption or damage. This indicator will be yellow.*



*Indicates important information regarding the operating condition, i.e. procedures essential for safe operation. This indicator will be green with the exception of the capacity indicator which will be green or yellow depending upon platform position.*

## SECTION 3 - MACHINE CONTROLS AND INDICATORS

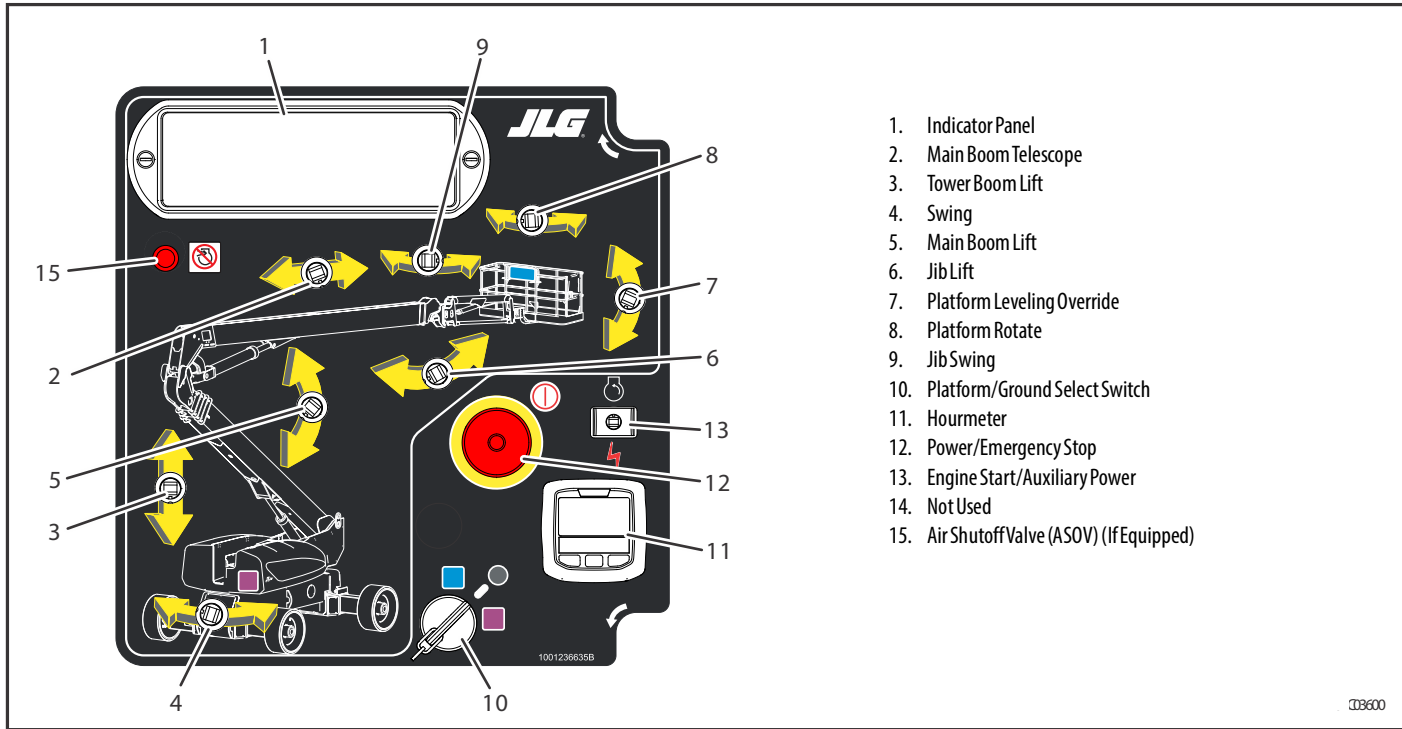
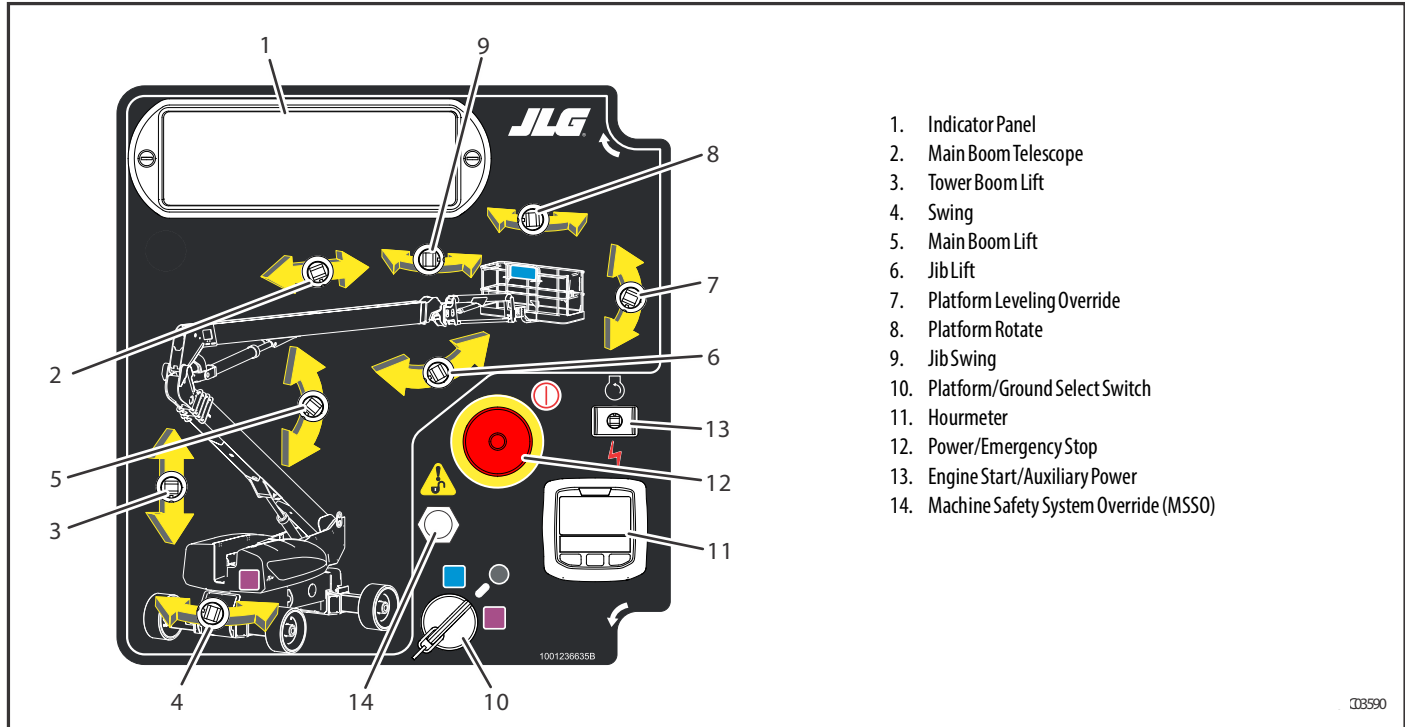

Figure 3-1. Ground Control Station without MSSO



1. Indicator Panel
2. Main Boom Telescope
3. Tower Boom Lift
4. Swing
5. Main Boom Lift
6. Jib Lift
7. Platform Leveling Override
8. Platform Rotate
9. Jib Swing
10. Platform/Ground Select Switch
11. Hourmeter
12. Power/Emergency Stop
13. Engine Start/Auxiliary Power
14. Machine Safety System Override (MSSO)

**Figure 3-2. Ground Control Station with MSSO**

## SECTION 3 - MACHINE CONTROLS AND INDICATORS

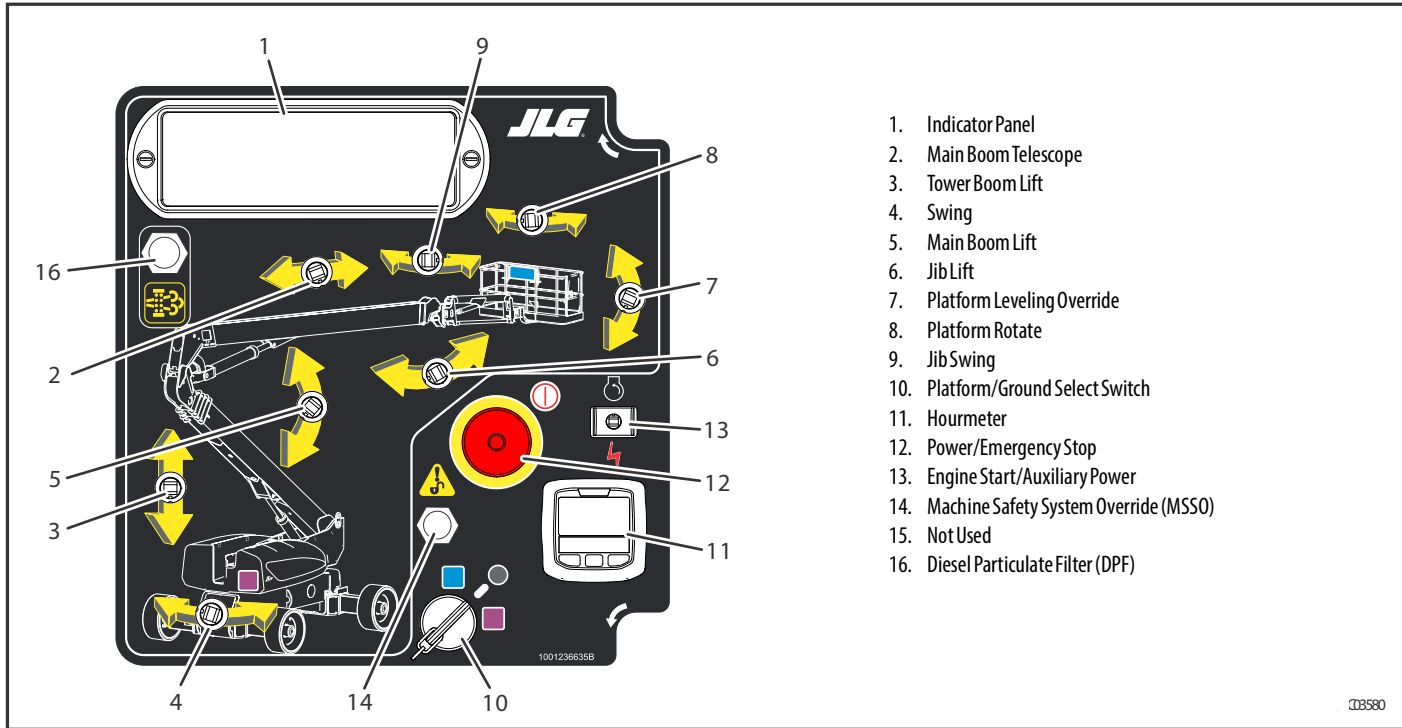

Figure 3-2. Ground Control Station with MSSO and DPF

### **⚠ WARNING**

**TO AVOID SERIOUS INJURY, DO NOT OPERATE MACHINE IF ANY CONTROL LEVERS OR TOGGLE SWITCHES CONTROLLING PLATFORM MOVEMENT DO NOT RETURN TO THE OFF POSITION WHEN RELEASED.**

## Ground Control Station

*(See Figure 3-1., Ground Control Station without MSSO) and Section 3-2., Ground Control Station with MSSO.*

### 1. Indicator Panel

The Indicator Panel contains indicator lights that signal problem conditions or functions operating during machine operation.

### 2. Main Boom Telescope

Provides extension and retraction of the main boom.

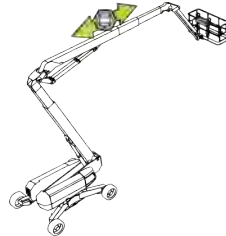

### 3. Tower Boom Lift

Provides raising and lowering of the tower boom.

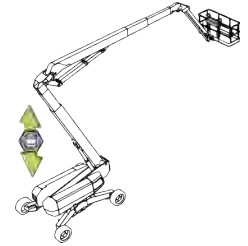

### 4. Swing

Provides 360 degrees continuous turntable rotation.

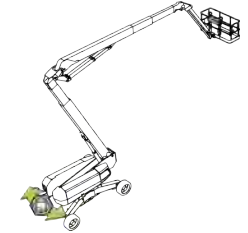

### 5. Main Boom Lift

Provides raising and lowering of the main boom.

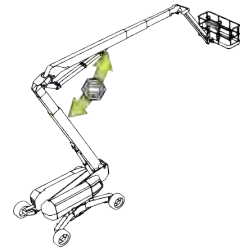

## SECTION 3 - MACHINE CONTROLS AND INDICATORS

### 6. Jib Lift

Provides raising and lowering of the jib.

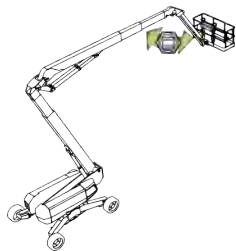

### **⚠ WARNING**

**ONLY USE THE PLATFORM LEVELING OVERRIDE FUNCTION FOR SLIGHT LEVELING OF THE PLATFORM. INCORRECT USE COULD CAUSE THE LOAD/OCCUPANTS TO SHIFT OR FALL. FAILURE TO DO SO COULD RESULT IN DEATH OR SERIOUS INJURY.**

### 7. Platform Leveling Override

A three position switch allows the operator to adjust the automatic self leveling system. This switch is used to adjust platform level in situations such as ascending/descending a grade.



### 8. Platform Rotate

Provides rotation of the platform.

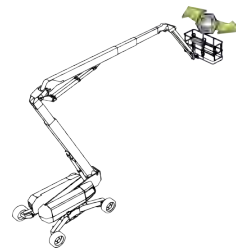

### 9. Jib Swing

Allows swinging of the jib.

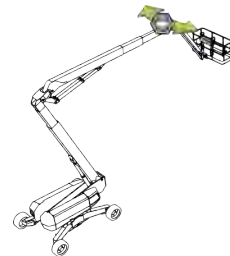

**NOTE:** *With Platform/Ground Select switch in the center position, power is shut off to controls at both operating stations.*



### 10. Platform/Ground Select Switch

A three position, key operated switch supplies power to the platform control console when positioned to Platform. With the switch key positioned in the Ground position, power is shut off to platform and only ground controls are operable.

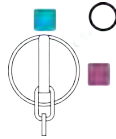

### 11. Hourmeter

Registers the amount of time the machine has been in use, with engine running. By connecting into the oil pressure circuit of the engine, only engine run hours are recorded. The hourmeter registers up to 9,999.9 hours and cannot be reset.

**NOTE:** When Power/Emergency Stop switch is in the On position and engine is not running, an alarm will sound, indicating Ignition is On.

### **NOTICE**

**WHEN THE MACHINE IS SHUT DOWN THE MASTER/EMERGENCY STOP SWITCH MUST BE POSITIONED TO THE OFF POSITION TO PREVENT DRAINING THE BATTERY.**

### 12. Power/Emergency Stop Switch

A two-position red mushroom shaped switch supplies power to Platform/Ground Select switch when pulled out (On). When pushed in (Off), power is shut off to the Platform/Ground Select switch.



**NOTE:** Auxiliary power only works if there is no engine oil pressure, and is disabled if engine is running.

*Functions will operate at a slower than normal rate because of the reduced hydraulic flow.*

### **NOTICE**

**WHEN USING AUXILIARY POWER, DO NOT OPERATE MORE THAN ONE FUNCTION AT A TIME. SIMULTANEOUS OPERATION CAN OVERLOAD THE AUXILIARY PUMP.**

### 13. Engine Start/ Auxiliary Power Switch

To start the engine, the switch must be held Up until the engine starts.



To use auxiliary power, the switch must be held Down for duration of auxiliary pump use.



## SECTION 3 - MACHINE CONTROLS AND INDICATORS

---

- 14.** Machine Safety System Override (MSSO)  
(If Equipped)

Provides emergency override of function controls that are locked out in the event of Load Sense System activation.



- 15.** Air Shutoff Valve (ASOV) (If Equipped)

The red LED ASOV light indicates when the valve has been actuated.



- 16.** Diesel Particulate Filter (DPF) (If Equipped)

This button initiates the standstill exhaust system cleaning.



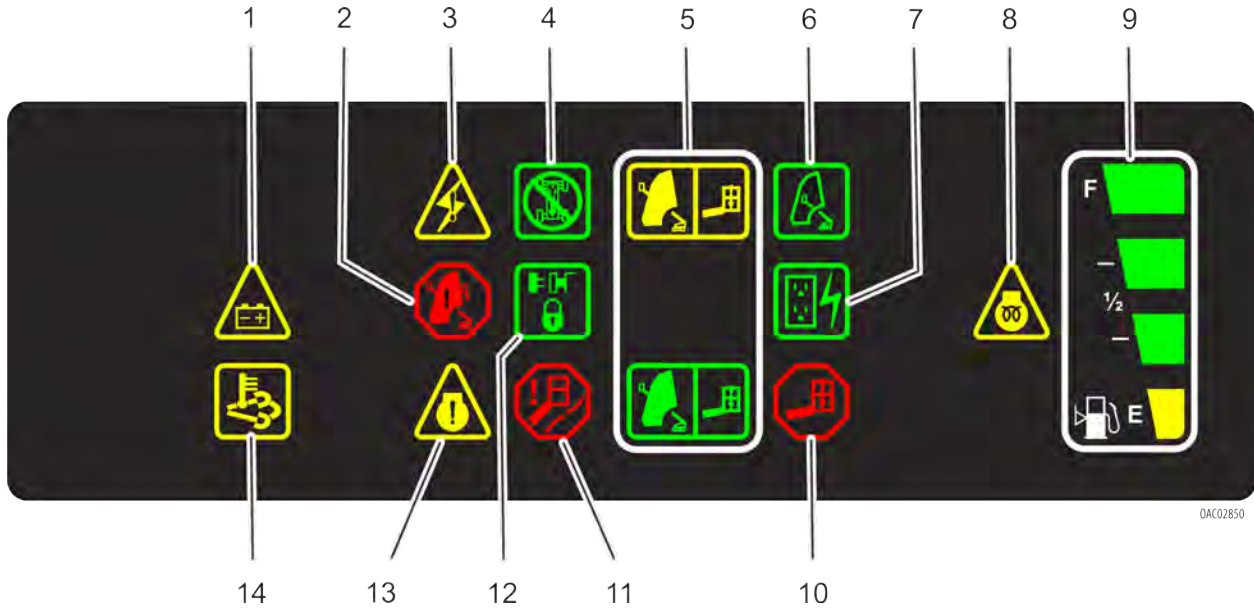

OAC02850

- |                                |                                   |                       |                           |
|--------------------------------|-----------------------------------|-----------------------|---------------------------|
| 1. Battery Charge              | 5. Capacity Zone Indicator        | 9. Fuel Gauge         | 13. Engine Error          |
| 2. Boom Control System Warning | 6. Boom Control System Calibrated | 10. Platform Overload | 14. Emissions Temperature |
| 3. System Distress             | 7. Generator                      | 11. Wire Rope Service |                           |
| 4. Drive Steer Disable         | 8. Glow Plugs                     | 12. Axles Set         |                           |

**Figure 3-3. Ground Control Indicator Panel**

## SECTION 3 - MACHINE CONTROLS AND INDICATORS

### Ground Control Indicator Panel

(See Figure 3-3., Ground Control Indicator Panel)

#### 1. Battery Charge Indicator

Indicates a problem in the battery or charging circuit, and service is required.



#### 2. Boom Control System Warning Indicator

Indicates the platform is outside the operating area and operation of certain boom functions may be disabled (i.e. lift, telescope). Attempts to use the disabled functions cause the indicator to flash and an alarm to sound. Immediately return the platform to the ground. If the indicator remains lit a boom control system fault or failure has been detected. If a failure is discovered, the system must be repaired by a JLG factory trained technician before the machine can be used.



#### 3. System Distress Indicator

The light indicates that the JLG Control System has detected an abnormal condition and a Diagnostic Trouble Code has been set in the system memory. Refer to the Service Manual for instructions concerning the trouble codes and trouble code retrieval. The system distress indicator light will illuminate for 2-3 sec-



onds when the key is positioned to the On position to act as a self test.

#### 4. Drive and Steer Disable Indicator

Indicates the Drive and Steer Disable function has been activated.



#### 5. Capacity Zone Indicator

Indicates the platform capacity zone for the current position of the platform. Restricted capacities are permitted at restricted platform positions (shorter boom lengths and higher boom angles).



#### 6. Boom Control System Calibrated Indicator

When illuminated, the light indicates the Boom Control System is properly calibrated.



#### 7. AC Generator Indicator

Indicates the generator is in operation.



## SECTION 3 - MACHINE CONTROLS AND INDICATORS

### 8. Glow Plug Indicator

Indicates the glow plugs are on. The glow plugs are automatically turned on with the ignition circuit and remain on for approximately seven seconds. Start the engine only after the light goes out.



### 9. Fuel Level Indicator

Indicates the level of the fuel in the fuel tank.

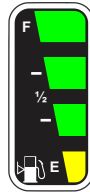

### 10. Platform Overload Indicator

Indicates the platform has been overloaded.



### 11. Wire Rope Indicator

When illuminated, the light indicates the wire ropes are loose or broken and must be repaired or adjusted prior to use.



### 12. Axles Set Indicator

Indicates the axles are fully extended. The indicator will flash as the axles are extending or retracting and be solid when fully extended. The indicator icon will go out when the axles are fully retracted.



### 13. Engine Error Indicator

Indicates a fault with the engine and service is required.



### 14. Emissions Temperature Warning Indicator

Icon illuminates when the engine emissions control sensor reaches a high temperature.



## SECTION 3 - MACHINE CONTROLS AND INDICATORS

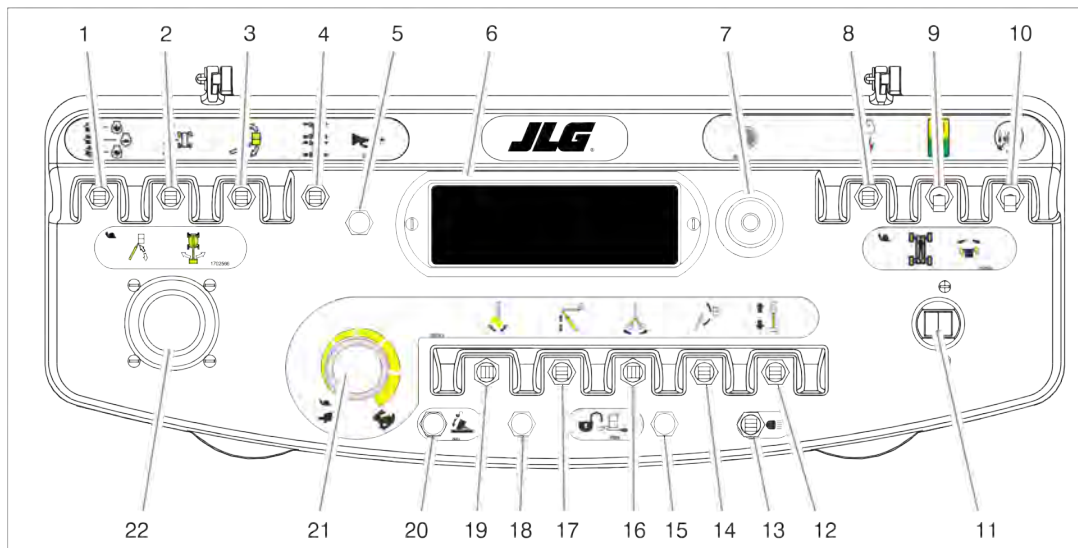

- |                              |                                  |  |                                   |
|------------------------------|----------------------------------|--|-----------------------------------|
| 1. Drive Speed/Torque Select | 7. Power/Emergency Stop          | 13. Lights/SkySense Mute                               | 18. Soft Touch/SkyGuard Indicator |
| 2. Steer Select              | 8. Engine Start/ Auxiliary Power | 14. Jib Lift   | 19. Platform Rotate               |
| 3. Platform Level Override   | 9. Capacity Select               | 15. Soft Touch/SkyGuard Override/<br>SkySense Override | 20. Jib Stow Override             |
| 4. Axle Extend/Retract       | 10. Drive Orientation Override   | 16. Jib Swing  | 21. Function Speed Control        |
| 5. Horn                      | 11. Drive/Steer                  | 17. Tower Boom Lift                                    | 22. Main Lift/Swing               |
| 6. Indicator Panel           | 12. Main Boom Telescope          |  |                                   |

**Figure 3-4. Platform Control Console**

**Platform Station**

(See Figure 3-4., Platform Control Console)

**⚠ WARNING**

**TO AVOID SERIOUS INJURY, DO NOT OPERATE MACHINE IF ANY CONTROL LEVERS OR TOGGLE SWITCHES CONTROLLING PLATFORM MOVEMENT DO NOT RETURN TO THE OFF OR NEUTRAL POSITION WHEN RELEASED.**

**1. Drive Speed/Torque Select**

The forward position gives maximum drive speed. The back position gives maximum torque for rough terrain and climbing grades. The center position allows the machine to be driven as quietly as possible.

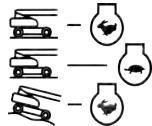

**2. Steer Select**

The action of the steering system is operator selectable. The center switch position gives conventional front wheel steering with the rear wheels unaffected. This is for normal driving at maximum speeds. The forward position is for “crab” steering. When in this mode both front and rear axles steer in the same direction, which allows the chassis to move sideways as it goes forward. This

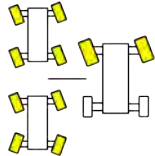

can be used for positioning the machine in aisle ways or close to buildings. The back switch position is for “coordinated” steering. In this mode the front and rear axles steer in the opposite directions to produce the tightest turning circle for maneuvering in confined areas.

**⚠ WARNING**

**ONLY USE THE PLATFORM LEVELING OVERRIDE FUNCTION FOR SLIGHT LEVELING OF THE PLATFORM. INCORRECT USE COULD CAUSE THE LOAD/OCCUPANTS TO SHIFT OR FALL. FAILURE TO DO SO COULD RESULT IN DEATH OR SERIOUS INJURY.**

**3. Platform Leveling Override**

A three position switch allows the operator to adjust the automatic self leveling system. This switch is used to adjust platform level in situations such as ascending/descending a grade.

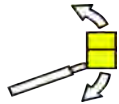

**4. Axle Extend/Retract**

Allows the operator to extend or retract the axles. The axles can only be extended or retracted while the machine is being driven forward or reverse.

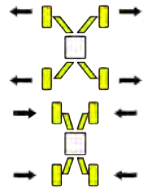

## SECTION 3 - MACHINE CONTROLS AND INDICATORS

### 5. Horn



A push-type Horn switch supplies electrical power to an audible warning device when pressed.

### 6. Indicator Panel

The LED Indicator Panel contains indicator lights that signal problem conditions or functions operating during machine operation.

Within about 2 seconds of pulling the Power/Emergency Stop switch out, the machine will perform a diagnostic check of the various electrical circuits, and if everything is OK, the platform alarm will beep once. During this time the lights on the indicator panel will also illuminate momentarily as a bulb check.

### 7. Power/Emergency Stop

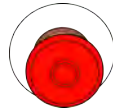

A two-position red mushroom shaped switch supplies power to Platform Controls when pulled out (on). When pushed in (off), power is shut off to the platform controls.

### 8. Engine Start/Auxiliary Power



When pushed forward, the switch energizes the starter motor to start the engine.

When pushed back, it energizes the electrically operated hydraulic pump, when actuated. (Switch must be held on for duration of auxiliary pump use.)The auxiliary pump functions to provide sufficient oil flow to operate the basic machine functions should the main pump or engine fail. The auxiliary pump will operate all functions except Drive/Steer and Axles.



### 9. Capacity Select



This switch allows the operator to select between an operating envelope with a 500 lb (227 kg for ANSI markets and 230 kg for CE and Australia markets) capacity restriction or a 1000 lb (454 kg for ANSI markets and 450 kg for CE and Australia markets) capacity restriction.



### 10. Drive Orientation Override

When the boom is swung over the rear tires or further in either direction, the Drive Orientation indicator will illuminate when the drive function is selected. Push and release the switch, and within 3 seconds move the Drive/Steer control to activate drive or steer. Before driving, locate the black/white orientation arrows on both the chassis and the platform controls. Move the drive controls in a direction matching the directional arrows for the intended direction of travel.



**NOTE:** To operate the Drive Joystick, pull up on the locking ring below the handle.

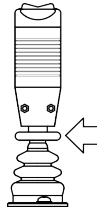

**NOTE:** The DRIVE control levers are spring-loaded and will automatically return to neutral (Off) position when released.

### 11. Drive/Steer

Push forward to drive forward, pull back to drive in reverse. Steering is accomplished via a thumb-activated rocker switch on the end of the steer handle.

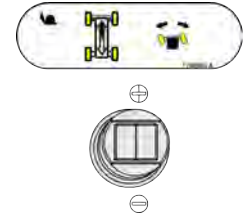

### 12. Main Boom Telescope

Provides extension and retraction of the main boom.

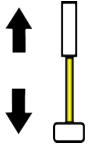

### 13. Lights/SkySense Mute (If Equipped)

Operates accessory light packages if the machine is so equipped.



If machine is equipped with SkySense, the switch will mute the SkySense speakers.



### 14. Jib Lift

Provides raising and lowering of the jib.

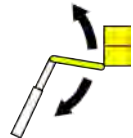

## SECTION 3 - MACHINE CONTROLS AND INDICATORS

### 15. Soft Touch/SkyGuard/SkySense Override Switch

For machines equipped with SkyGuard:

The SkyGuard override switch enables functions cut out by the Skyguard system to be operated again, allowing the operator to resume use of machine functions.



For machines equipped with both SkyGuard and Soft Touch:

The switch operates like the SkyGuard override switch as described above. The switch also enables the functions cut out by the Soft Touch system to operate again at creep speed, allowing the operator to move the platform away from the obstacle that caused the shut-down situation.



For machines equipped with both SkyGuard and SkySense:

The switch operates like the SkyGuard override switch as described above. The switch also enables the functions cut out by the SkySense system to operate again at creep speed, allowing the operator to move the platform closer to the obstacle that caused the shut-down situation if desired.



### 16. Jib Swing

Allows the operator to swing the jib to the left or right.



**NOTE:** *The Jib Swing function is not operable when the Capacity Select control is in the 1000 lb (454 kg for ANSI markets and 450 kg for CE and Australia markets) position.*

### 17. Tower Boom Lift

Allows raising and lowering of the tower boom by activating the tower lift and telescope cylinders as dictated by the Boom Control System.

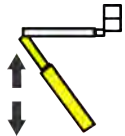

### 18. Soft Touch/SkyGuard Indicator

Indicates the Soft Touch bumper is against an object or the SkyGuard sensor has been activated. All controls are cut out until the override button is pushed. For Soft Touch, controls are then active in the Creep Mode or for SkyGuard, controls will work normally.

## SECTION 3 - MACHINE CONTROLS AND INDICATORS

### 19. Platform Rotate

Allows the operator to rotate the platform to the left or right.



**NOTE:** To operate the Main Boom Lift/Swing joystick, pull up on the locking ring below the handle.

**NOTE:** The Main Boom Lift/Swing joystick is spring loaded and will automatically return to neutral (off) position when released.

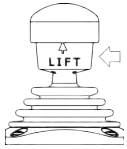

### 20. Jib Stow Override

Allows the operator to swing the jib to the right past the electronic stop to stow the jib beside the boom for transport.



### 22. Main Lift/Swing Controller

Provides Main Lift and Swing. Push forward to lift up, pull backward to boom down. Move right to swing right, move left to swing left.

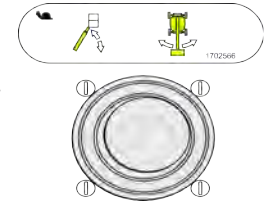

### 21. Function Speed Control

This control knob affects the speed of the Main Boom Telescope, Tower Boom Lift, Jib Lift, Jib Swing, and Platform Rotate functions.



**NOTE:** During platform rotation and jib swing, a speed difference may not be noticeable to the operator.

Turning the knob all the way counterclockwise until it clicks puts the machine into Creep Mode. Creep Mode puts the functions listed above as well as the Drive/Steer and Main Lift/Swing functions into the slowest speed setting.

## SECTION 3 - MACHINE CONTROLS AND INDICATORS

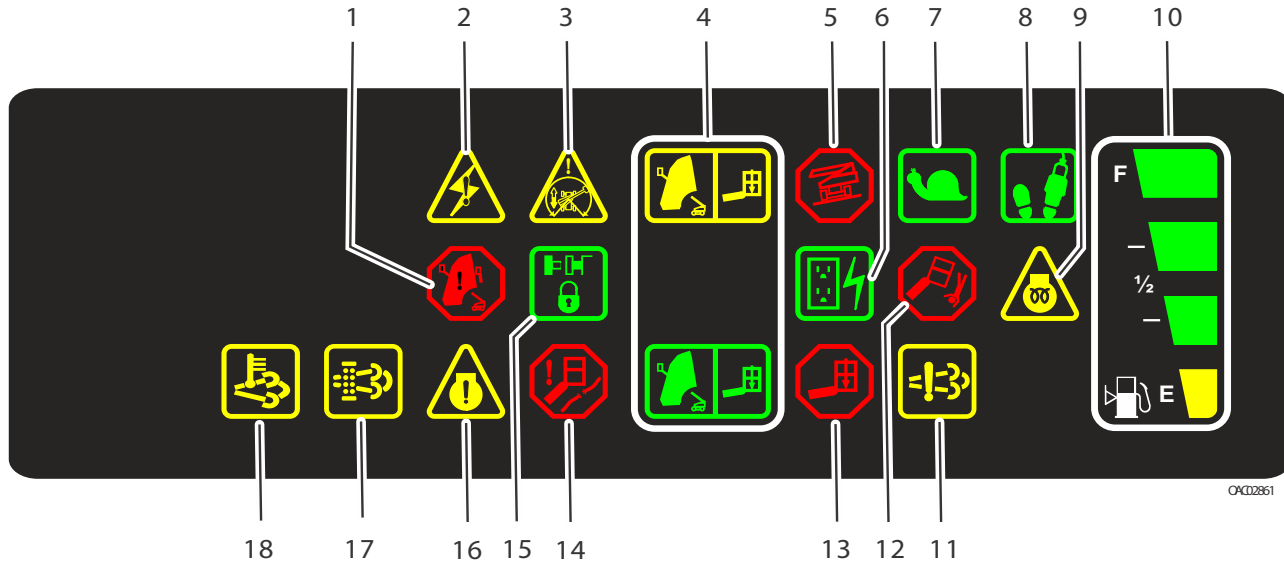

CAK02861

- |                                |                      |                       |                                     |
|--------------------------------|----------------------|-----------------------|-------------------------------------|
| 1. Boom Control System Warning | 6. Generator         | 11. Emissions Failure | 16. Engine Error                    |
| 2. System Distress             | 7. Creep             | 12. Level System      | 17. Diesel Particulate Filter (DPF) |
| 3. Drive Orientation           | 8. Footswitch Enable | 13. Platform Overload | 18. Emissions Temperature           |
| 4. Capacity Zone Indicator     | 9. Glow Plugs        | 14. Wire Rope Service |                                     |
| 5. Tilt Alarm Warning          | 10. Fuel Gauge       | 15. Axles Set         |                                     |

**Figure 3-5. Platform Control Indicator Panel**

**Platform Control Indicator Panel**

(See Figure 3-5., Platform Control Indicator Panel)

**1. Boom Control System Warning Indicator**

Indicates the platform is outside the operating area and operation of certain boom functions may be disabled (i.e. lift, telescope). Attempts to use the disabled functions cause the indicator to flash and an alarm to sound. Immediately return the platform to the ground. If the indicator remains lit, a boom control system fault or failure has been detected. If a failure is discovered, the system must be repaired by a JLG factory trained technician before the machine can be used.



**2. System Distress Indicator**

The light indicates that the JLG Control System has detected an abnormal condition and a Diagnostic Trouble Code has been set in the system memory. Refer to the Service Manual for instructions concerning the trouble codes and trouble code retrieval.



**3. Drive Orientation Indicator**

When the boom is swung beyond the rear drive tires or further in either direction, the



**4. Capacity Zone Indicator**

Indicates the maximum platform capacity zone for the current position of the platform. Restricted capacities are permitted at restricted platform positions (shorter boom lengths and higher boom angles).

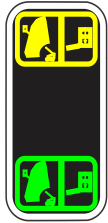

**NOTE:** Refer to the capacity decals on the machine for restricted and unrestricted platform capacities.

**5. Tilt Warning Light and Alarm**

This red illuminator indicates that the chassis is on a slope. If the boom is above horizontal and the machine is on a slope, the tilt alarm warning light will illuminate, an alarm will sound, available functions are placed in Creep speed, and drive is cut out in direction of travel. Drive in the opposite direction may be allowed under certain conditions.



Tilt Angle	Market
5°	All Markets

## SECTION 3 - MACHINE CONTROLS AND INDICATORS

### **WARNING**

IF TILT WARNING LIGHT IS ILLUMINATED WHEN BOOM IS RAISED OR EXTENDED, RETRACT AND LOWER TO BELOW HORIZONTAL THEN REPOSITION MACHINE SO THAT IT IS WITHIN THE LIMITS OF THE MAXIMUM OPERATING SLOPE BEFORE EXTENDING BOOM OR RAISING BOOM ABOVE HORIZONTAL.

**NOTE:** *When the tilt sensor alarm is activated the Drive function will be disabled if the boom is elevated above horizontal.*

#### 6. AC Generator Indicator

Indicates the generator is in operation.



#### 7. Creep Speed Indicator

When the Function Speed Control is turned to the creep position, the indicator acts as a reminder that all functions are set to the slowest speed.



#### 8. Footswitch/Enable Indicator

To operate any function, the footswitch must be depressed and the function selected within seven seconds. The enable indicator shows that the controls are enabled. If a function is not selected within seven seconds, or if a seven second lapse between ending one function and beginning the next function, the enable light will go out and the footswitch must be released and depressed again to enable the controls.



Releasing the footswitch removes power from all controls and applies the drive brakes.

### **WARNING**

**TO AVOID SERIOUS INJURY, DO NOT REMOVE, MODIFY OR DISABLE THE FOOTSWITCH BY BLOCKING OR ANY OTHER MEANS.**

#### 9. Glow Plug Indicator

Indicates the glow plugs are operating. After turning on ignition, wait until light goes out before cranking engine.



## SECTION 3 - MACHINE CONTROLS AND INDICATORS

### 10. Fuel Level Indicator

Indicates the level of the fuel in the fuel tank.

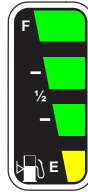

### 11. Engine Emissions System Failure Indicator

Icon illuminates when there is a fault with the Emissions After Treatment system.



### 12. Level System Indicator

Indicates a fault in the electronic leveling system. The fault indicator will flash and an alarm will sound. All functions will default to creep if the boom is extended past transport mode or elevated more than 8 degrees above horizontal.



### 13. Platform Overload Indicator

Indicates the platform has been overloaded.



### 14. Wire Rope Service

When illuminated, the light indicates the wire ropes are loose or broken and must be repaired or adjusted prior to use.



### 15. Axles Set Indicator

Indicates the axles are fully extended. The indicator will flash as the axles are extending or retracting and be solid when fully extended. The indicator icon will go out when the axles are fully retracted.



### 16. Engine Error Indicator

Indicates a fault with the engine and service is required.



### 17. Diesel Particulate Filter (DPF) Indicator

Icon will illuminate when standstill exhaust system cleaning is required.



## **SECTION 3 - MACHINE CONTROLS AND INDICATORS**

---

### **18. Emissions Temperature Indicator**

Icon illuminates when the engine emissions control sensor reaches a high temperature.





## **SECTION 4. MACHINE OPERATION**

### **4.1 DESCRIPTION**

This machine is a mobile elevating work platform used to position personnel, along with their necessary tools and materials at work locations.

The primary operator control console is in the platform. From this control console, the operator can drive and steer the machine in both forward and reverse directions. The operator can raise or lower the boom or swing the boom to the left or right. The machine can be driven on a smooth, firm surface within the limits of the maximum operating slope from an elevated platform position. Refer to the subsection Steering and Traveling of this manual for specific requirements. The machine has a Ground Control Station that can override the Platform Control Station. Ground controls operate all functions except Drive and Steer. Except for performing inspections and the Function Check, the ground controls are to be used in an emergency to lower the platform to the ground should the operator in the platform be unable to do so.

### **4.2 HYDRAULIC SYSTEM WARM UP**

The control system monitors the hydraulic system in extremely cold temperatures and provides optimal performance by automatically limiting the function speeds of the high demand functions. The warm up mode automatically shuts off when system oil reaches allowable temperatures.

While the system is cold and in the warm up mode, the tower lift, main lift, and main telescope functions are limited to creep speeds and is indicated to the operator by flashing the creep light on the platform control panel.

Functions being operated when the warm up mode turns off will remain in the creep speed until the function is re-initiated.

## SECTION 4 - MACHINE OPERATION

---

### 4.3 ENGINE OPERATION

**NOTE:** When operating a machine at high altitudes, a decrease in machine performance may occur due to a decrease in air density.

**NOTE:** When operating a machine at high ambient temperatures, a decrease in machine performance and an increase in engine coolant temperature may occur.

**NOTE:** Contact JLG Customer Service for operation under abnormal conditions.

**NOTE:** Initial starting should always be performed from the Ground Control console.

### Starting Procedure

#### **NOTICE**

**IF ENGINE FAILS TO START PROMPTLY, DO NOT CRANK FOR AN EXTENDED TIME. SHOULD ENGINE FAIL TO START AGAIN, ALLOW STARTER TO COOL OFF FOR 2-3 MINUTES. IF ENGINE FAILS AFTER SEVERAL ATTEMPTS, REFER TO ENGINE MAINTENANCE MANUAL.**

**NOTE:** If the engine fails to start due to cold temperatures or excessive amounts of smoke are produced on startup, wait for the glow plug/wait to start indicator to glow out before starting the engine.

1. Turn key of Platform/Ground Select switch to Ground.
2. Pull the Power/Emergency Stop switch out.
3. Push the Engine Start switch until engine starts.

#### **NOTICE**

**ALLOW ENGINE TO WARM-UP FOR A FEW MINUTES AT LOW SPEED BEFORE APPLYING ANY LOAD.**

4. After engine has had sufficient time to warm up, shut engine off.
5. Turn Platform/Ground Select switch to Platform.
6. Pull out the Ground Console Power/Emergency Stop switch to provide power to the platform controls.
7. From Platform, pull Power/Emergency Stop switch out.
8. Push the Engine Start switch until engine starts.

**NOTE:** Footswitch must be in released (up) position before starter will operate. If starter operates with footswitch in the depressed position, DO NOT OPERATE MACHINE.

## Shutdown Procedure

### NOTICE

**IF AN ENGINE MALFUNCTION CAUSES AN UNSCHEDULED SHUTDOWN, DETERMINE THE CAUSE AND CORRECT IT BEFORE RESTARTING THE ENGINE.**

1. Remove all load and allow engine to operate at low speed for 3-5 minutes; this allows further reduction of internal engine temperature.
2. Push Power/Emergency Stop switch in.
3. Turn key of the Platform/Ground Select switch to the Off position.

Refer to Engine Manufacturer's manual for detailed information.

## Air Shutoff Valve (ASOV) (If Equipped)

Air Shutoff Valve (ASOV) is an overspeed protection device mounted to the engine's air intake system. When the valve is actuated, it obstructs airflow intake and stops the engine. Weekly tests are recommended to ensure the valve remains in good working condition.

1. Start the engine, running at idle.
2. Open the red switch guard on ASOV test switch, then activate toggle to test mode.

**NOTE:** *Test switch is located under hood to the left of the engine (look for test decal).*

3. At the ground control panel, select any function and activate until valve actuates at test RPM of 1500. Once valve actuates, engine will stop.
4. Turn ignition to Off.
5. Visually inspect valve to ensure it appears in good condition.
6. Reset valve by rotating valve handle to the Open position.

**NOTE:** *The handle cannot be turned unless the machine is off. Ensure the ignition is moved to the Off position.*



### **⚠ WARNING**

**DO NOT USE ASOV AS AN ALTERNATIVE TO SHUTTING DOWN MACHINE PROPERLY.**

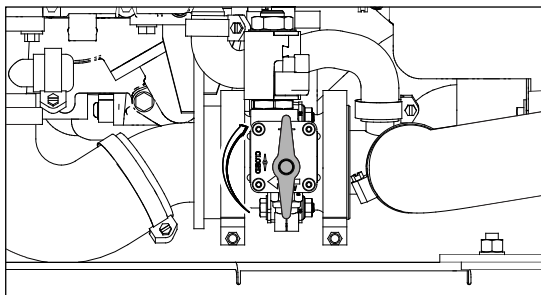
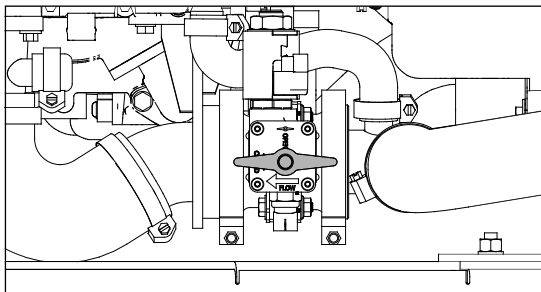

**Figure 4-1. ASOV Reset (Open to Closed Position)**

## Fuel Reserve / Shut-Off System

**NOTE:** Reference the Service and Maintenance Manual along with a qualified JLG Mechanic to verify your machine setup.

The Fuel Shutoff System monitors the fuel in the tank and senses when the fuel level is getting low. The JLG Control System automatically shuts the engine down before the fuel tank is emptied unless the machine is set up for Engine Restart.

If fuel level reaches the Low Fuel range the  $\frac{1}{4}$  tank indicator will flash once a second and there will be approximately 5 minutes of engine run time left. If the system is in this condition and automatically shuts down the engine, or the engine is manually shut down before the 5 minute run time is complete, the  $\frac{1}{4}$  tank indicator will flash 10 times a second and the engine will react according to machine setup. Setup options are as follows:

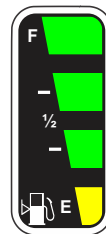

- Engine One Restart - When the engine shuts down, the operator will be permitted to cycle power and restart the engine once with approximately 2 minutes of run time. After the 2 minute run time is complete or if the engine is shut down by the operator prior to the completion of the 2 minute run time, it cannot be restarted until fuel is added to the tank.

- Engine Restart - When the engine shuts down, the operator will be permitted to cycle power and restart the engine for approximately 2 minutes of run time. After the 2 minutes of run time is complete, the operator may cycle power and restart the engine for an additional 2 minutes of run time. The operator can repeat this process until there is no more fuel available.

### NOTICE

**CONTACT A QUALIFIED JLG MECHANIC IF THE MACHINE NEEDS RESTARTED AFTER NO MORE FUEL IS AVAILABLE.**

- Engine Stop - The engine will shut down. No restarts will be permitted until fuel is added to the tank.

#### 4.4 DIESEL PARTICULATE FILTER (IF EQUIPPED)

Diesel Particulate Filter (DPF) is an emissions control system used in diesel engines and requires operator interaction to make sure proper operation of the system.

For peak operation, the DPF system must be cleaned using one of two methods, Standstill Cleaning and Maintenance Standstill Cleaning. Standstill Cleaning is any cleaning requested by the engine outside of the regular maintenance window (for example, if the system detects excessive soot in the DPF canister). Maintenance Standstill Cleaning is cleaning requested by the engine on the regular maintenance interval.

**NOTE:** *The system will reset the maintenance interval back to zero hours after Standstill or Maintenance Standstill Cleaning events are performed.*

#### Standstill Cleaning

The following conditions must be met to perform Standstill Cleaning.

- Machine must be stationary
- Boom in the stowed position
- No personnel in platform
- Engine must be idling
- Coolant temperature must be above 104° F (40° C)
- Machine in Ground Station mode

1. The Diesel Particulate Filter (DPF) Indicator on the Platform Control Panel will flash when standstill cleaning is required.



2. Move the machine to an suitable area free of flammables and personnel that could be exposed to hot exhaust.

## SECTION 4 - MACHINE OPERATION

---

3. Launch the cleaning process by pressing the DPF button on the Ground Console for 3 seconds. The Indicator Gauge will display the following screen.



4. The Main Cleaning process will begin and last for approximately 30 to 60 minutes. The following screen will show that the process has begun and includes a status bar that indicates the progress of the cleaning process.



5. After the cleaning process is complete, the engine will run for approximately 5 minutes to allow the engine and Exhaust After Treatment (EAT) to cool down. The Indicator Gauge will display the "Regen Complete" screen as shown and the Emissions Temperature indicator will no longer be illuminated.



### **Maintenance Standstill Cleaning Initiation Methods**

Maintenance Standstill Cleaning can be started by one of two methods, by using the Analyzer or the DPF button on the Ground Console. All the same conditions as outlined under Standstill Cleaning must be met.

### **Canceling Maintenance Standstill**

Maintenance Standstill Cleaning will be stopped immediately if:

- The Platform/Ground Select switch is switched from Ground to Platform mode
- Any function switch is enabled to perform a boom function
- The Engine is powered down

If Maintenance Standstill Cleaning is interrupted, it must be re-initiated and the Indicator Gauge will display the "Regen Failed" screen as shown.



### **Unsuccessful Cleaning Event**

If there is an unsuccessful cleaning event, the DPF icon will show on the display gauge. Possible causes of an Unsuccessful Cleaning Event are:

- Engine is not warmed up
- DEF tank is frozen
- Machine functions operated during cleaning event in progress
- Other engine faults are active

The Gauge will display "Regen Failed" screen as shown. If the cleaning event has failed, the process must be repeated.



### **DPF Filter Replacement due to Ash Load**



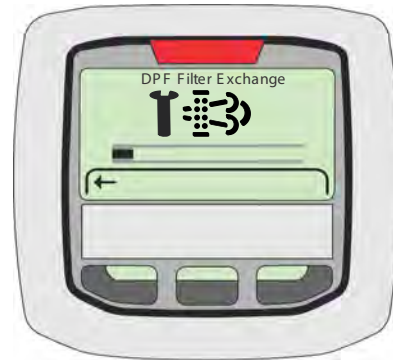

The DPF collects non-burnable particulates which cannot be removed by the Standstill Cleaning process. Build up of the ash load requires filter maintenance and/or exchange.

DPF filter maintenance or exchange requirement is indicated by the DPF Exchange icon shown on the display gauge.





























**Table 4-1. Ash Load DPF Filter Replacement**

	<b>Ash Load</b>	<b>DPF Filter Exchange Indicator</b>	<b>Engine Error Indicator</b>	<b>Derate</b>
Normal Operation	< 100%	--	--	None
Filter Exchange Required	≥ 100%		--	None
Warning Level	≥ 105%	Blinking 	--	None
Warning Level	≥ 110%	Blinking 	Continuous 	Machine placed in Creep and DTC active. Contact Deutz Dealer

## SECTION 4 - MACHINE OPERATION

Standstill Cleaning Levels		Machine Hours Since Last Cleaning	Engine Error Indicator	DPF Indicator	Emissions Temperature Indicator*	Derate	Comments
0	Normal Operation	0-500	--	--		None	Between 500 and 650 hours, cleaning cycle can be initiated with JLG analyzer.
		500-650					
1	Standstill Required	650-750	--			None	Engine coolant temperature must be >40°C and machine must be in ground station mode.
2	Warning Level	750-775	Continuous 			Machine placed in Creep and DTC active	
3	Shut Off Level	>775	Blinking 			Idle Lock. Boom Functions Locked Out and trapped in Transport.	Contact Deutz Dealer
4	Filter Exchange	DPF Regeneration NOT POSSIBLE DPF Filter exchange required	Blinking 			Idle Lock. Boom Functions Locked Out and trapped in Transport.	

\*Emissions Temperature indicator continuously ON during Standstill Cleaning

Soot Levels	Soot Load/ Time	DPF Cleaning Initiation Methods	Engine Error Indicator	DPF Indicator	Emissions Temperature Indicator*	Derate	Comments
Normal Operation	<99%		--	--		None	
Standstill Required	100% to 109% or 100 Hours	Switch in JLG Machine or JLG Analyzer	--			None	Will remain in Standstill mode for 100 hours or until the soot load reaches 109%
Warning Level	109% to 125% or 25 Hours	Switch in JLG Machine or JLG Analyzer	Continuous 			Machine placed in Creep and DTC active	Will remain in Warning level (Derate) for 25 hours or until the soot load reaches 125%
Shut Off Level	125% to 161%	DPF Cleaning Not Possible	Blinking 			Idle Lock. Boom Functions Locked Out and Trapped in Transport	Contact Deutz Dealer
Filter Exchange	> 161%	DPF Cleaning Not Possible	Blinking 			Idle Lock. Boom Functions Locked Out and Trapped in Transport	
*Emissions Temperature indicator continuously ON during Standstill Cleaning							

### 4.5 BOOM OPERATING CHARACTERISTICS AND LIMITATIONS

#### Capacities

The boom can be raised from the transport position with or without any load in platform, if:

1. Machine is positioned on a smooth, firm surface within the limits of the maximum operating slope.
2. Axles are extended.
3. Load is within manufacturer's rated design capacity.
4. All machine systems are functioning properly.
5. Machine is as originally equipped from JLG.

#### Envelope Control System

The Envelope Control System is the primary means of controlling the working positions of the tower and main boom within the stability and structural requirements of the machine.

The main boom must be controlled in maximum angle and minimum angle to avoid entering a position that could compromise backward stability and avoid main boom to tower boom interference. The tower boom must be controlled by permitting only specific combinations of tower length and tower angle to avoid

entering a position that could compromise forward and backward stability (see Tower Path Control System).

Recognized failures within this system will result in control by the Electrical Retrieval System (refer to the Service Manual), reduced function speeds, and BCS warning light illumination. After retrieval the boom will be restricted from leaving the transport position until the failure is resolved.

Boom position violations outside of the allowable envelope will result in reduced function speeds, BCS warning light illumination, and restriction of functions. Attempts to operate restricted functions will cause the BCS warning light to flash and the platform alarm to sound.

Violations of the tower path (with a healthy control system) will cause the automatic combined operation of tower lift and tower telescope to be suspended. A forward tower path violation can be resolved by operating the tower lift up switch (tower telescope out without auto tower lift up) or the tower lift down switch (tower lift down without auto tower telescope in). A backward tower path violation can be resolved by operating the tower lift up switch (tower lift up without auto tower telescope out) or the tower lift down switch (tower telescope in without auto tower lift down).

The restricted functions due to backward tower envelope violations are disallowing automatic tower lift down, automatic tower

telescope out, main lift up and down, main telescope in, jib, swing, drive and steer.

The restricted functions due to forward tower envelope violations are disallowing automatic tower lift up, automatic tower telescope in, main lift up and down, main telescope out, jib, swing, drive and steer.

The restricted functions due to maximum main boom envelope violations are disallowing tower lift up and down, main lift up, main telescope in, jib, swing and drive.

The restricted functions due to minimum main boom envelope violations are disallowing main lift down, swing and drive.

## **Tower Path Control System**

The Tower Path Control System uses the envelope control sensors to enhance the control of the tower boom for increased user efficiency and is used as an integral part of the envelope control system.

Both the ground and platform control panels use one function switch to control the tower. User commands for tower lift up or tower lift down causes the control system to automatically introduce the correct combination of tower telescope and tower lift for the tower boom to follow a pre-described path or trajectory of the tower nose.

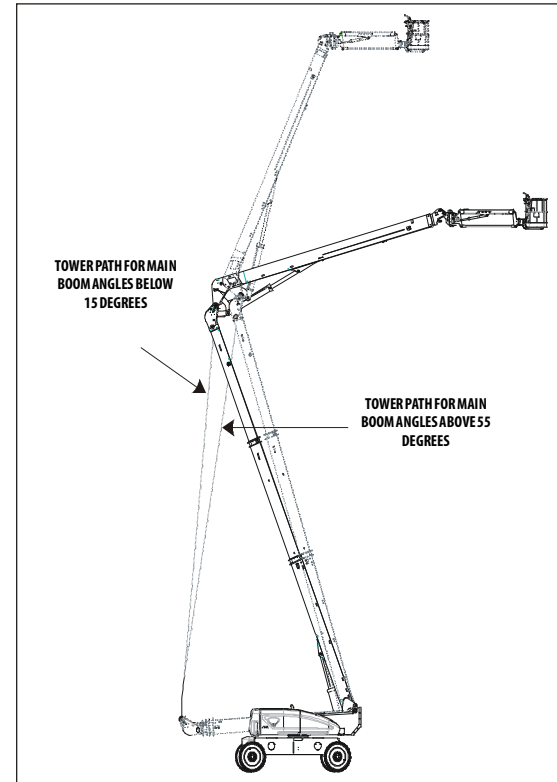

### Automatic Main Boom Control System

During combined tower lift and main lift functions, the control system will maintain the tower lift speed and automatically vary the maximum main lift command as needed to compensate for the movement of the tower.

The interaction of the main boom and the tower boom is slightly different when the main boom is above or below 60° relative to gravity.

#### TOWER LIFT UP/DOWN - MAIN BOOM BELOW 60°

During tower lift up or down with the main boom below 60°, the control system will maintain the angle of the main boom read at the start of the tower lift command or as read at the conclusion of main lift during combined tower and main lift commands.

#### TOWER LIFT DOWN - MAIN BOOM ABOVE 60°

During tower lift down with the main boom initially above 60°, the control system will lower the main boom to approximately 60° before starting tower movement. The control system will then control the main boom to 60° for the remainder of the tower lift down command.

#### TOWER LIFT UP - MAIN BOOM ABOVE 60°

During tower lift up with the main boom already above 60°, the control system will delay automatic compensation of the main boom angle during tower lift until the main boom reaches approximately 60°. The control system will then control the main

boom to 60° until the tower boom has reached its maximum height. Continuing to operate the tower lift up when the tower reaches its maximum height will cause the control system to automatically raise the main boom to its original angle.

### Slow Down System

The control system uses the envelope control sensors to automatically slow down the tower lift up and tower lift down at the top of the tower path and to automatically slow down main lift up and main lift down as the minimum and maximum angles of the working envelope are approached. The control system indicates to the operator this slow down by flashing the creep light on the platform display. This applies to both platform and ground controls, however, no indication is made on the ground control panel.

### Controlled Angle

The Controlled Boom Angle System minimizes the interaction of swing and drive functions with the envelope edges. This interaction is due to two factors. First, the envelope is controlled relative to gravity regardless of ground slope and second, the turntable/boom mounting is effected by swing and drive functions when the ground slope varies. This can cause the boom position to vary within the envelope or even violate the envelope edges when swinging or driving without intentionally moving the boom. The controlled boom angle system automatically activates either the

tower or main boom lift up or down during swing and drive commands to maintain a constant boom angle relative to gravity.

Controlled boom angle is disabled with any envelope violation or failure.

## **Swing Speed Proportioning**

The boom control system sensors sense the distance the platform is extended from the centerline of rotation, allowing higher swing speeds with the platform nearest to the centerline of rotation and gradually slower swing speeds the further the platform gets from the centerline of rotation.

## **Platform Load Sensing System (LSS)**

The Platform Load Sensing System provides the platform capacity to the control system.

If the LSS system senses an overload condition, boom functions will be disabled, the overload indicator is illuminated at both control stations, and the overload alarm will sound. Reduce the weight in the platform to not exceed the rated workload indicated on the capacity decal, then the controls will work again.

## **Stability**

Machine stability is based on two (2) conditions which are called FORWARD and BACKWARD stability. The machine's position of least FORWARD stability is shown in (See Figure 4-3.), and its position of least BACKWARD stability is shown in (See Figure 4-5.)



**TO AVOID FORWARD OR BACKWARD TIPPING, DO NOT OVERLOAD MACHINE OR OPERATE THE MACHINE BEYOND THE LIMIT OF THE MAXIMUM OPERATING SLOPE.**

## SECTION 4 - MACHINE OPERATION

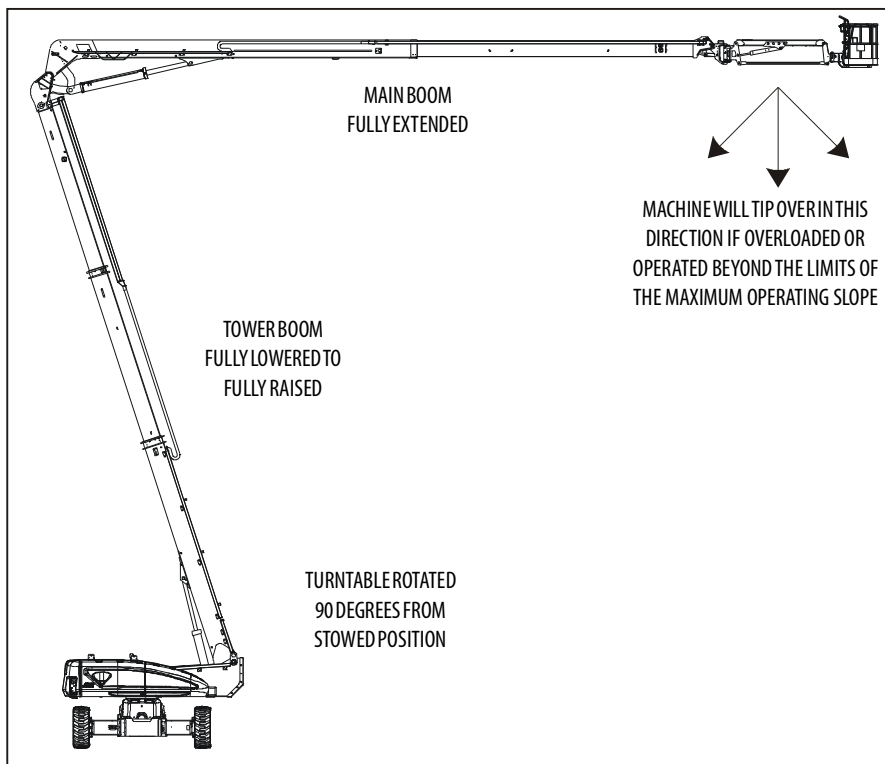

**Figure 4-3. Position of Least Forward Stability**



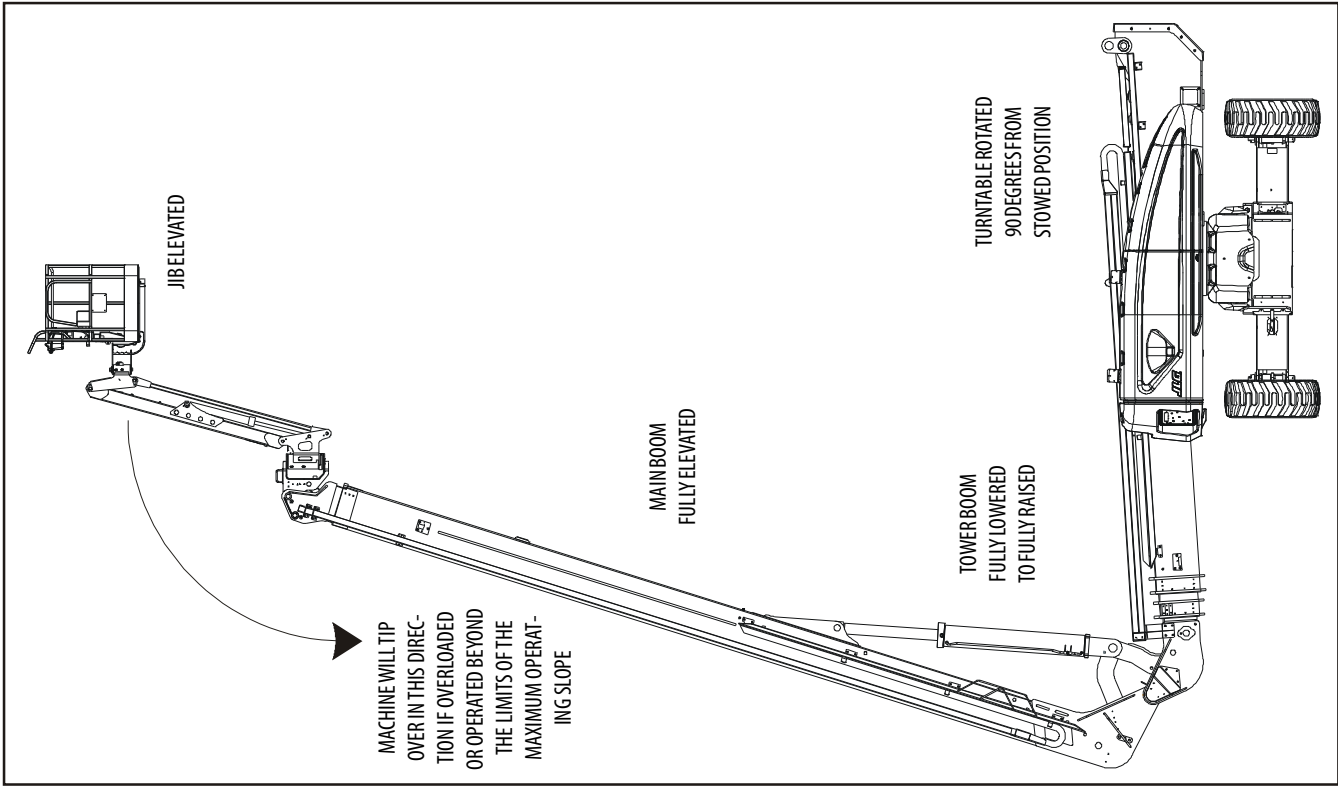

Figure 4-4. Position of Least Backward Stability - Sheet 1 of 2

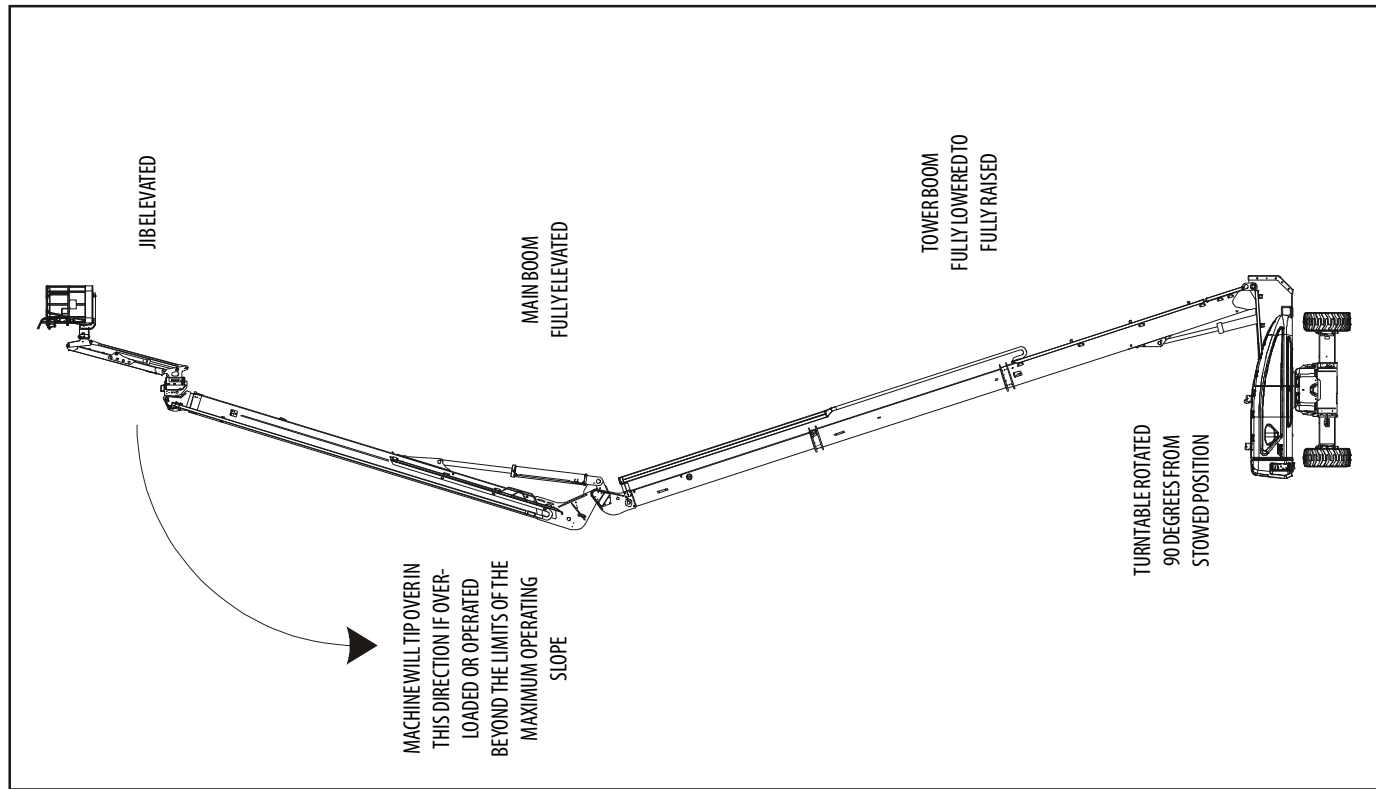

Figure 4-5. Position of Least Backward Stability - Sheet 2 of 2

## **4.6 AUXILIARY POWER OPERATION**

The Auxiliary Power System provides a means of moving the platform in the event of an engine malfunction. This system uses an electric motor/pump unit capable of operating all boom functions needed to allow the platform to be lowered to ground level.

With auxiliary power activated, the control system will attempt to use the force of gravity to operate main lift down, tower lift down, and tower telescope in. If appropriate movement is not detected by the boom sensors, the auxiliary power system will supply hydraulic flow to power boom movement. Allow sufficient operating time for system to respond.

**NOTE:** *To ensure sufficient battery life, where possible, use the Main Lift and Main Telescope functions to lower the platform to ground level before using Tower Lift. Movements of the boom using auxiliary power will be Slow and the movements will momentarily stop and alternate between other functions as needed. When operating Tower Lift, the movements will alternate between tower lift, tower telescope, and main lift. When operating Main Lift, the movements will alternate between main lift, tower lift, and platform level.*

## **4.7 CAPACITY SELECT**

The Boom Control System allows the operator to select operation in a 500 lb (227 kg for ANSI markets and 230 kg for CE and Australia markets) capacity restriction envelope or a 1000 lb (454 kg for ANSI markets and 450 kg for CE and Australia markets) capacity restriction envelope. The operator selects the desired capacity restriction by positioning the Capacity Select switch on the platform console. The Capacity Indicator shows the capacity selected, and both capacity lights will flash and an alarm sound if the platform is out of the selected capacity range.

**NOTE:** *Operation in the 1000 lb (454 kg for ANSI markets and 450 kg for CE and Australia markets) envelope requires the jib to be fixed in the centered position.*

# SECTION 4 - MACHINE OPERATION

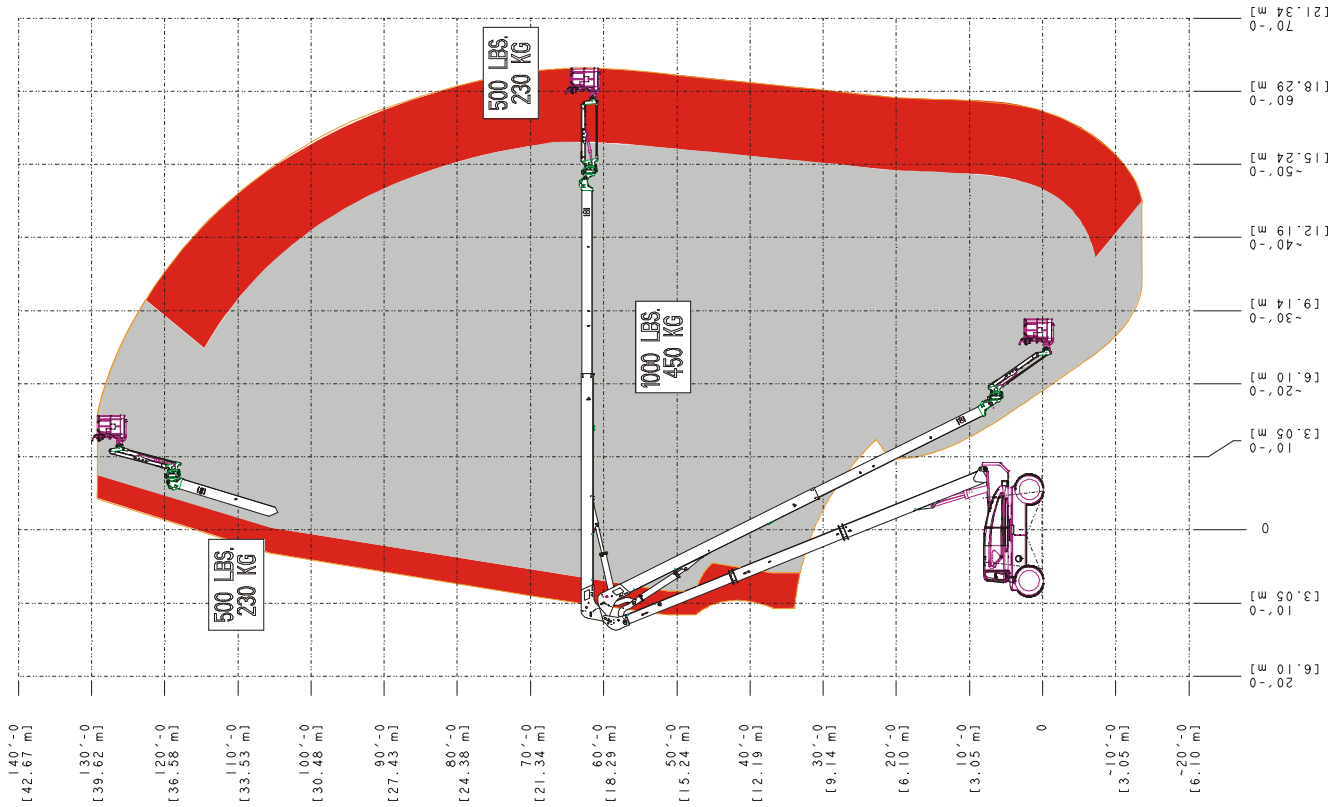

Figure 4-6. Range Diagram

## **4.8 TRAVELING (DRIVING)**

See Figure 4-7., Grade and Side Slopes

**NOTE:** *Refer to the Operating Specifications table for Gradeability and Sideslope ratings.*

*All ratings for Gradeability and Sideslope are based upon the machine's boom being in the stowed position, fully lowered, and retracted.*

Traveling is limited by two factors:

- 1.** Gradeability, which is the percent of grade of the incline the machine can climb.
- 2.** Sideslope, which is the angle of the slope the machine can be driven across.

When the boom is raised or extended, the machine must not be operated on grades or sideslopes that are greater than that detected by the tilt alarm. The tilt alarm will sound to alert the operator when the machine is on an unsafe slope. The machines high drive function will also be cut back to low drive.

### **⚠ WARNING**

**DO NOT DRIVE WITH BOOM ABOVE HORIZONTAL EXCEPT ON A SMOOTH, FIRM AND LEVEL SURFACE WITHIN THE LIMITS OF THE MAXIMUM OPERATING SLOPE.**

**TO AVOID LOSS OF TRAVEL CONTROL OR TIP OVER, DO NOT DRIVE MACHINE ON GRADES EXCEEDING THOSE SPECIFIED IN THE OPERATING SPECIFICATIONS SECTION OF THIS MANUAL.**

**DO NOT DRIVE ON SIDESLOPES WHICH EXCEED 5 DEGREES.**

**USE EXTREME CAUTION WHEN DRIVING IN REVERSE AND AT ALL TIMES WHEN DRIVING WITH THE PLATFORM ELEVATED.**

**BEFORE DRIVING, LOCATE THE BLACK/WHITE ORIENTATION ARROWS ON BOTH THE CHASSIS AND THE PLATFORM CONTROLS. MOVE THE DRIVE CONTROLS IN A DIRECTION MATCHING THE DIRECTIONAL ARROWS FOR THE INTENDED DIRECTION OF TRAVEL.**

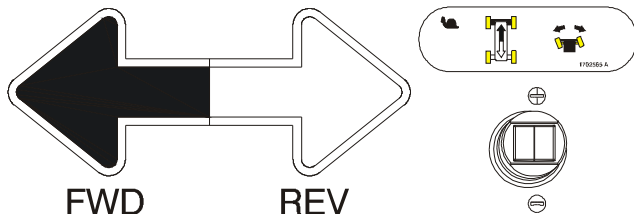

## Traveling Forward and Reverse

1. At Platform Controls, pull out Emergency Stop switch, start engine, and activate footswitch.
2. Position Drive controller to Forward or Reverse as desired.

This machine is equipped with a Drive Orientation Indicator. The yellow light on the platform control console indicates that the boom is swung beyond the rear drive tires and the machine may Drive/Steer in the opposite direction from the movement of the controls. If the indicator is illuminated, operate the Drive function in the following manner:

1. Match the black and white direction arrows on both platform control panel and the chassis to determine the direction the machine will travel.
2. Push and release the Drive Orientation Override switch. Within 3 seconds, slowly move the Drive control toward the arrow matching the intended direction of machine travel. The indicator light will flash during the 3 second interval until the drive function is selected.

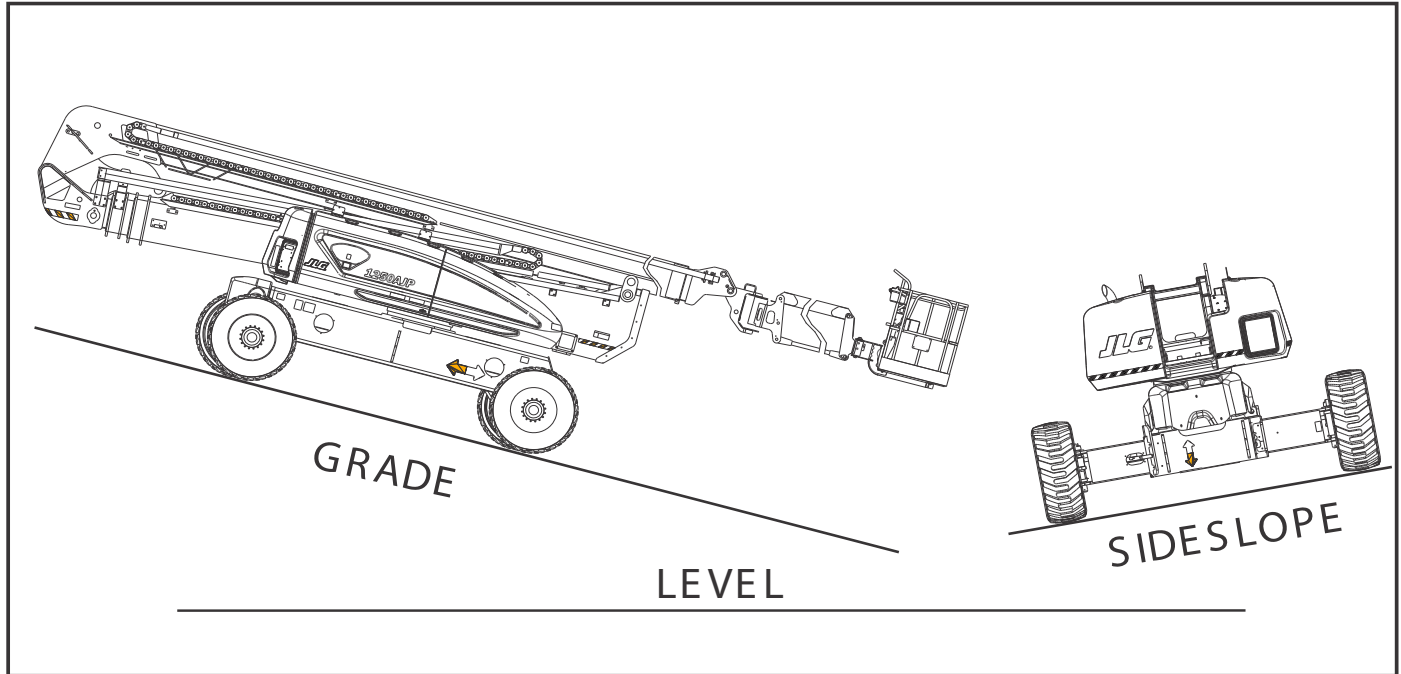

Figure 4-7. Grade and Side Slopes

### Traveling on a Grade

When traveling a grade, maximum braking and traction are obtained with the boom stowed, in position over the rear axle, and in line with the direction of travel. Drive the machine forward when climbing a grade, and in reverse when descending a grade. Do not exceed the machine's maximum rated gradeability.

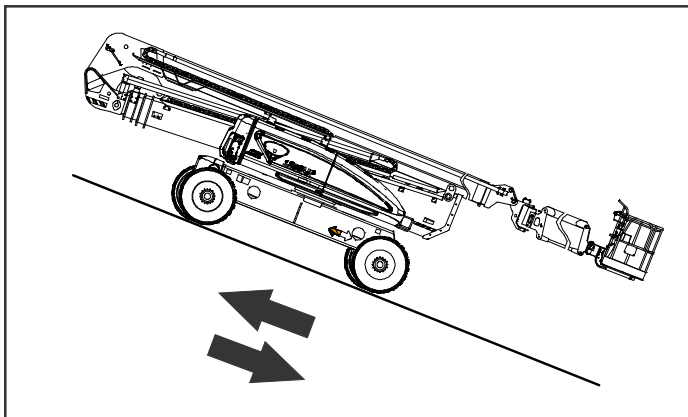

Figure 4-8. Traveling on a Grade

#### **NOTICE**

IF THE BOOM IS OVER THE FRONT (STEER) AXLE, DIRECTION OF STEER AND DRIVE MOVEMENT WILL BE OPPOSITE FROM THE MOVEMENT OF THE CONTROLS.

### 4.9 STEERING

Position thumb switch on Drive/Steer controller to Right for steering right, or to Left for steering left.

### 4.10 EXTENDING THE AXLES

**NOTE:** *The operator must be driving the machine (forward or reverse) in order to extend the axles.*

Position the Axle Extend switch to extend the axles or to retract to retract the axles.

### 4.11 PLATFORM

#### Platform Level Adjustment

#### **⚠ WARNING**

**ONLY USE THE PLATFORM LEVELING OVERRIDE FUNCTION FOR SLIGHT LEVELING OF THE PLATFORM. INCORRECT USE COULD CAUSE THE LOAD/OCCUPANTS TO SHIFT OR FALL. FAILURE TO DO SO COULD RESULT IN DEATH OR SERIOUS INJURY.**

**NOTE:** *Platform Leveling is active during all functions except during main boom telescope operations.*

During normal operation of the machine, the platform will automatically maintain its position. To manually Level Up or Down -



Position the Platform/Level control switch Up or Down and hold until the desired platform position is obtained.

## **Platform Rotation**

To rotate the platform to the left or right, use the Platform Rotate control switch to select the direction and hold until desired position is reached.

### **4.12 BOOM**

#### **⚠ WARNING**

A RED TILT WARNING LIGHT IS LOCATED ON THE CONTROL CONSOLE WHICH LIGHTS WHEN THE CHASSIS IS ON AN EXCESSIVE SLOPE. DO NOT SWING OR RAISE BOOM ABOVE HORIZONTAL WHEN LIGHT IS LIT.

DO NOT DEPEND ON TILT ALARM AS A LEVEL INDICATOR FOR THE CHASSIS. TILT ALARM INDICATES CHASSIS IS ON AN EXCESSIVE SLOPE (5 DEGREES OR GREATER). CHASSIS MUST BE LEVEL BEFORE SWINGING, OR RAISING BOOM ABOVE HORIZONTAL OR DRIVING WITH THE BOOM ELEVATED.

TO AVOID TIP OVER IF RED TILT WARNING LIGHT LIGHTS WHEN BOOM IS RAISED ABOVE HORIZONTAL, LOWER PLATFORM TO GROUND LEVEL. THEN REPOSITION MACHINE SO THAT CHASSIS IS LEVEL BEFORE RAISING BOOM.

TRAVELING WITH BOOM BELOW HORIZONTAL IS PERMITTED ON GRADES AND SIDE SLOPES SPECIFIED IN THE OPERATING SPECIFICATIONS SECTION OF THIS MANUAL.

#### **⚠ WARNING**

TO AVOID SERIOUS INJURY, DO NOT OPERATE MACHINERY IF ANY CONTROL LEVER OR TOGGLE SWITCH CONTROLLING PLATFORM MOVEMENT DOES NOT RETURN TO THE 'OFF' OR NEUTRAL POSITION WHEN RELEASED.

#### **⚠ CAUTION**

TO AVOID A COLLISION AND INJURY IF PLATFORM DOES NOT STOP WHEN A CONTROL SWITCH OR LEVER IS RELEASED, REMOVE FOOT FROM FOOTSWITCH OR USE EMERGENCY STOP SWITCH TO STOP THE MACHINE.

## **Swinging the Boom**

To swing boom, use Swing control to select Right or Left direction.

#### **NOTICE**

WHEN SWINGING THE BOOM MAKE SURE THERE IS AMPLE ROOM FOR THE BOOM TO CLEAR SURROUNDING WALLS, PARTITIONS AND EQUIPMENT.

## SECTION 4 - MACHINE OPERATION

---

### Raising and Lowering the Main Boom

**NOTE:** *The main lift function is not operable with the boom out of the transport mode if the axles are not fully extended.*

To raise or lower the Main Boom, use Boom Lift control to select Up or Down movement.

### Telescoping the Main Boom

**NOTE:** *The telescope function is not operable beyond the transport position if the axles are not fully extended.*

To extend or retract the main boom, use the Telescope Control Switch to select In or Out movement.

### Tower Lift

**NOTE:** *The control system automatically uses a combination of tower telescope and tower lift for the tower boom to follow a pre-described path.*

To raise or lower the tower boom, use the Tower Boom Lift control to select Up or Down movement.

### Swinging the Jib

**NOTE:** *For 1000 lb (454 kg for ANSI markets and 450 kg for CE and Australia markets) mode operation, the jib must be centered and the Jib Swing function is not operable. If the jib is out of the centered position when in this mode, the jib swing function will allow the operator to center the jib again.*

To swing the jib, use the Jib Swing control to select Right or Left direction.

### 4.13 FUNCTION SPEED CONTROL

This control affects the speed of all boom functions and Platform Rotate. When in the CCW maximum position, Drive is placed in creep speed.

### 4.14 MACHINE SAFETY SYSTEM OVERRIDE (MSSO) (IF EQUIPPED)

The Machine Safety System Override (MSSO) is used to override function controls for Emergency Platform Retrieval only. Refer to Section 5.5, Machine Safety System Override (MSSO) (If Equipped) for operating procedures.



## 4.15 SKYGUARD OPERATION

SkyGuard provides enhanced control panel protection. When the SkyGuard sensor is activated, functions in use at the time of activation will reverse or cutout. The SkyGuard Function Table provides more details on these functions.

During activation, the horn will sound and, if equipped with a SkyGuard beacon, the beacon will illuminate until sensor and footswitch are disengaged.

If the SkyGuard sensor remains activated after function reversal or cutout, depress and hold the SkyGuard Override Switch to allow normal functions until the sensor is disengaged.

Consult the following illustrations to determine which type of SkyGuard the machine has. Regardless of type, SkyGuard function according to the SkyGuard Function Table does not change.

### SkyGuard

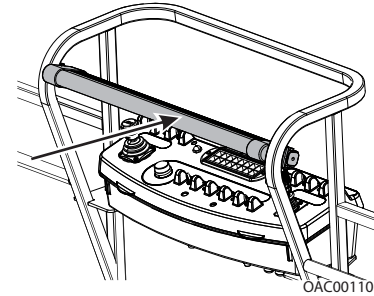

Approximately 50 lb (222 Nm) of force is applied to yellow bar.

### SkyGuard - SkyLine

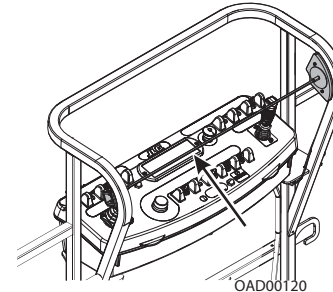

Cable is pressed, breaking the magnetic connection between the cable and right bracket.

**SkyGuard - SkyEye**

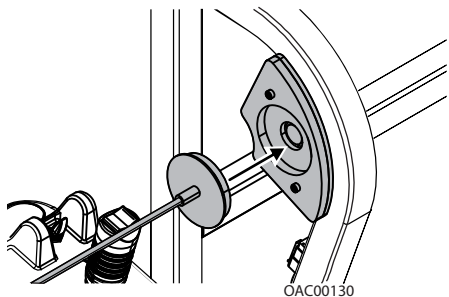

Reattach magnetic end of cable to bracket if it becomes disconnected.

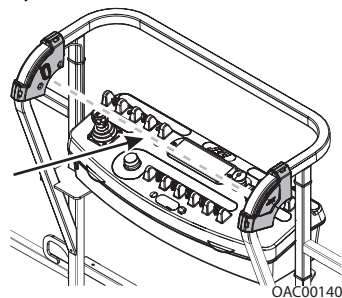

Operator passes through path of sensor beam.

**SkyGuard Function Table**

Drive Forward	Drive Reverse	Steer	Swing	Tower Lift Up	Tower Tele Out	Tower Lift Down	Tower Tele In	Boom Lift Up	Boom Lift Down	Boom Tele Out	Boom Tele In	Jib Lift	Jib Swing	Basket Level	Basket Rotate
R*/C**	R	C	R	C	C	C	C	R	R	R	C	C	C	C	C
R = Indicates Reversal is Activated															
C = Indicates Cutout is Activated															
* DOS (Drive Orientation System) Enabled															
** DOS Not Enabled, machine is driving straight without steering, and any other hydraulic function is active															
<b>Note:</b> If SkyGuard is enabled with the Soft Touch system, functions will cut out instead of reversing.															

## 4.15 EMERGENCY TOWING

### **WARNING**

**RUNAWAY VEHICLE/MACHINE HAZARD. MACHINE HAS NO TOWING BRAKES. TOWING VEHICLE MUST BE ABLE TO CONTROL MACHINE AT ALL TIMES. ON-HIGHWAY TOWING NOT PERMITTED. FAILURE TO FOLLOW INSTRUCTIONS COULD CAUSE SERIOUS INJURY OR DEATH.**

**MAXIMUM TOWING SPEED 5 MPH (8 KM/H)**

**MAXIMUM TOWING GRADE 25%.**

### **NOTICE**

**DO NOT TOW MACHINE WITH ENGINE OPERATING OR DRIVE HUBS ENGAGED.**

1. Retract, lower and position boom in travel position; lock turntable.
2. Disconnect drive hubs by inverting disconnect cap.
3. Reconnect the drive hubs by inverting the disconnect cap when towing is complete.

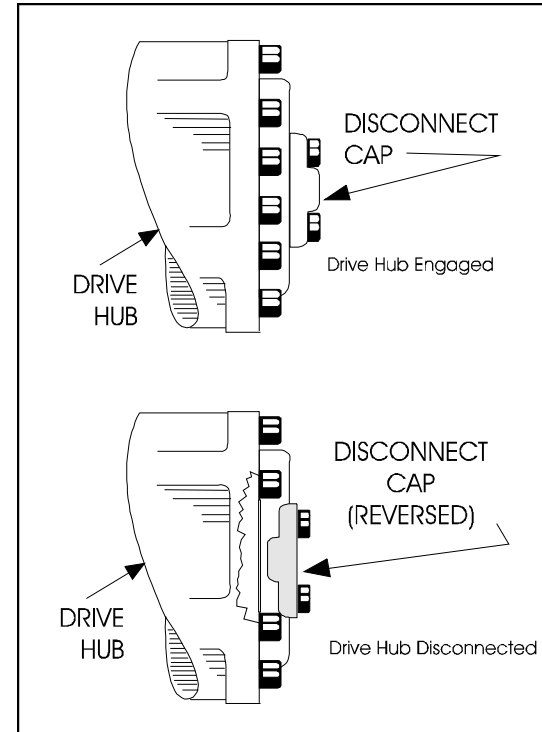

**Figure 4-9. Drive Disconnect Hub**

### 4.16 SHUT DOWN AND PARK

The preferred procedures to shut down and park the machine are as follows:

1. Drive machine to a reasonably well protected area.
2. Ensure boom is fully retracted and lowered over rear axle.
3. Shut down Emergency Stop at Platform Controls.
4. Shut down Emergency Stop at Ground Controls. Position Platform/Ground Select switch to center Off.
5. If necessary, cover Platform Controls to protect instruction placards, warning decals, and operating controls from hostile environment.

#### **NOTICE**

**IF PARKING A MEWP WITH THE BOOM ELEVATED IN AN EFFORT TO CONSERVE SPACE, BOOMS MAY BE ELEVATED, BUT SHALL NOT BE EXTENDED. IT IS THE OPERATOR'S RESPONSIBILITY TO ENSURE ALL SAFETY PRECAUTIONS IN SECTION 1 OF THIS MANUAL ARE FOLLOWED FOR EACH UNIQUE SITUATION.**

### 4.17 LIFTING AND TIE DOWN

(See Figure 4-10.)

#### **Lifting**

1. The weight of the machine is stamped on the serial number plate. If the plate is missing or illegible, call JLG Industries or weigh the individual unit to find out the Gross Vehicle Weight.
2. Place the boom in the stowed position with the turntable locked.
3. Remove all loose items from the machine.
4. Attach lifting device and equipment only to the designated lifting points.
5. Properly adjust the rigging to prevent damage to the machine and so the machine remains level.

## **Tie Down**

**NOTICE**

**WHEN TRANSPORTING THE MACHINE, THE BOOM MUST BE FULLY LOWERED INTO THE BOOM REST.**

1. Place the boom in the stowed position with the turntable locked.
2. Remove all loose items from the machine.
3. Secure the chassis and the platform using straps or chains of adequate strength and attached to the designated tie down points.

## **4.18 STOWING THE JIB FOR TRANSPORT**

1. Place the boom in the stowed position with the axles retracted.
2. Hold the Jib Swing control switch to the right until the platform will no longer swing.

**NOTE:** *The Jib Swing function is not operable when the Capacity Select control is in the 1000 lb (454 kg for ANSI markets and 450 kg for CE and Australia markets) position.*

**NOTE:** *Automatic platform leveling is disabled when stowing the jib.*

3. Push and hold the Jib Stow Override control switch until the jib and platform are in the stowed position under the boom.

## SECTION 4 - MACHINE OPERATION

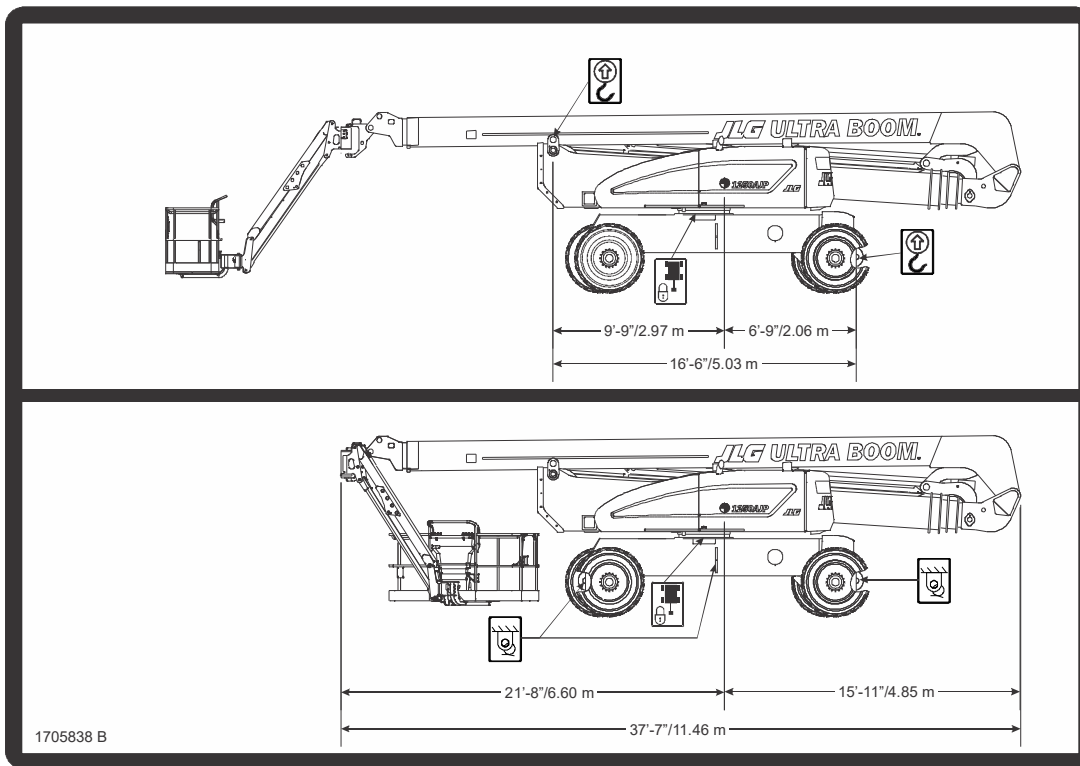

Figure 4-10. Lifting and Tie Down Chart



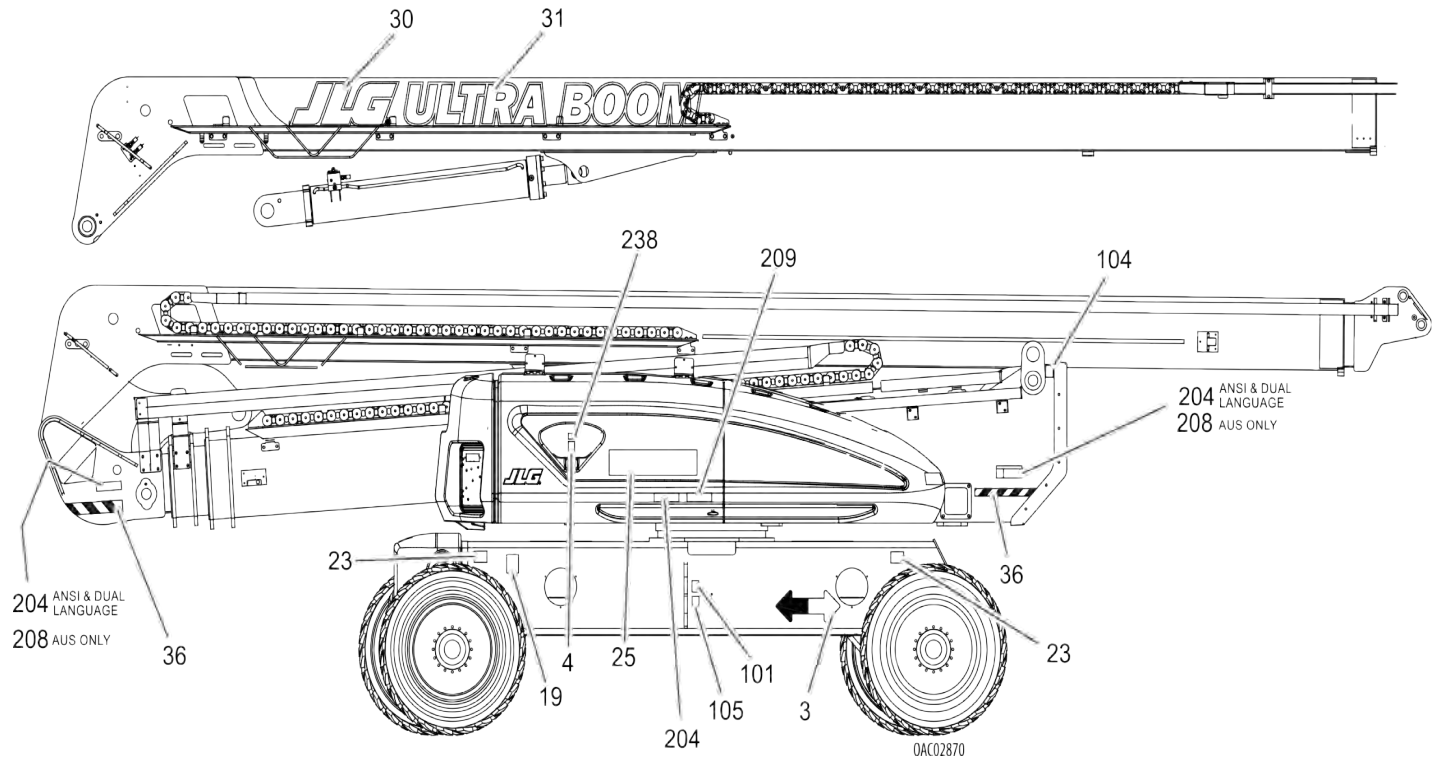

Figure 4-11. Decal Location Sheet 1 of 5

## SECTION 4 - MACHINE OPERATION

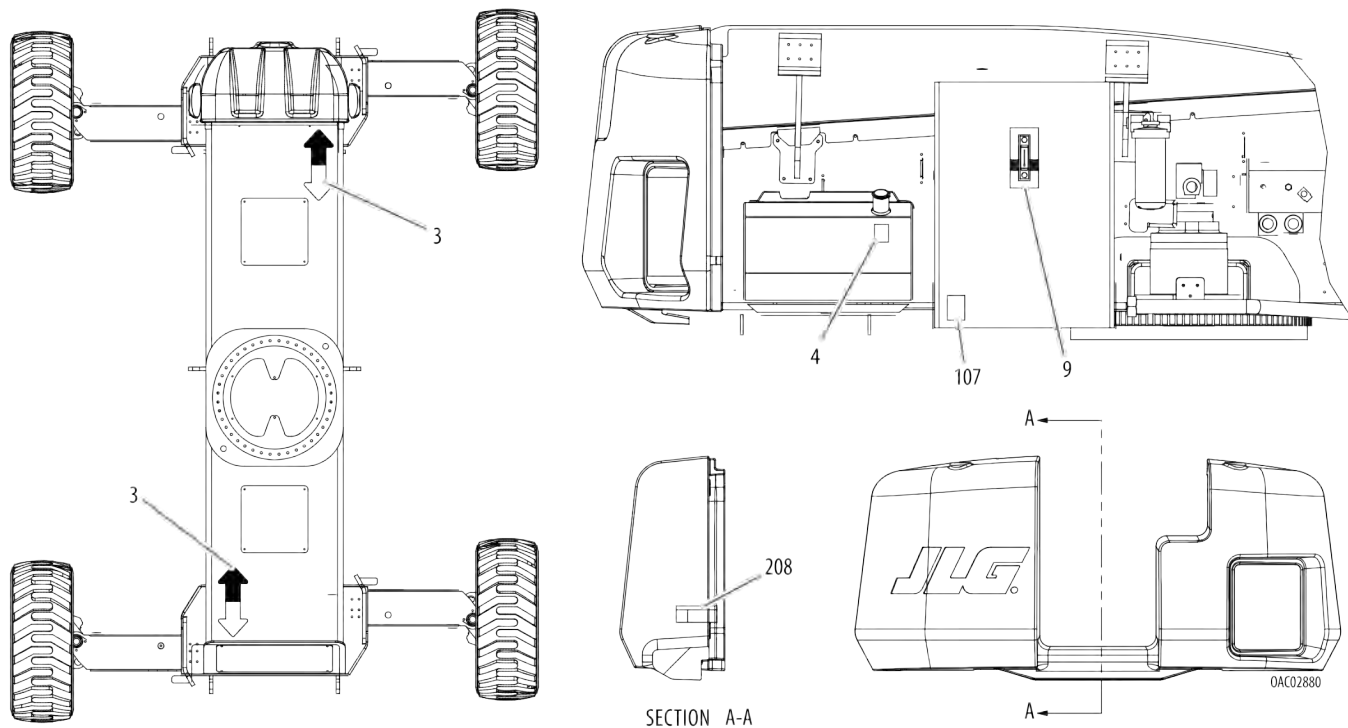
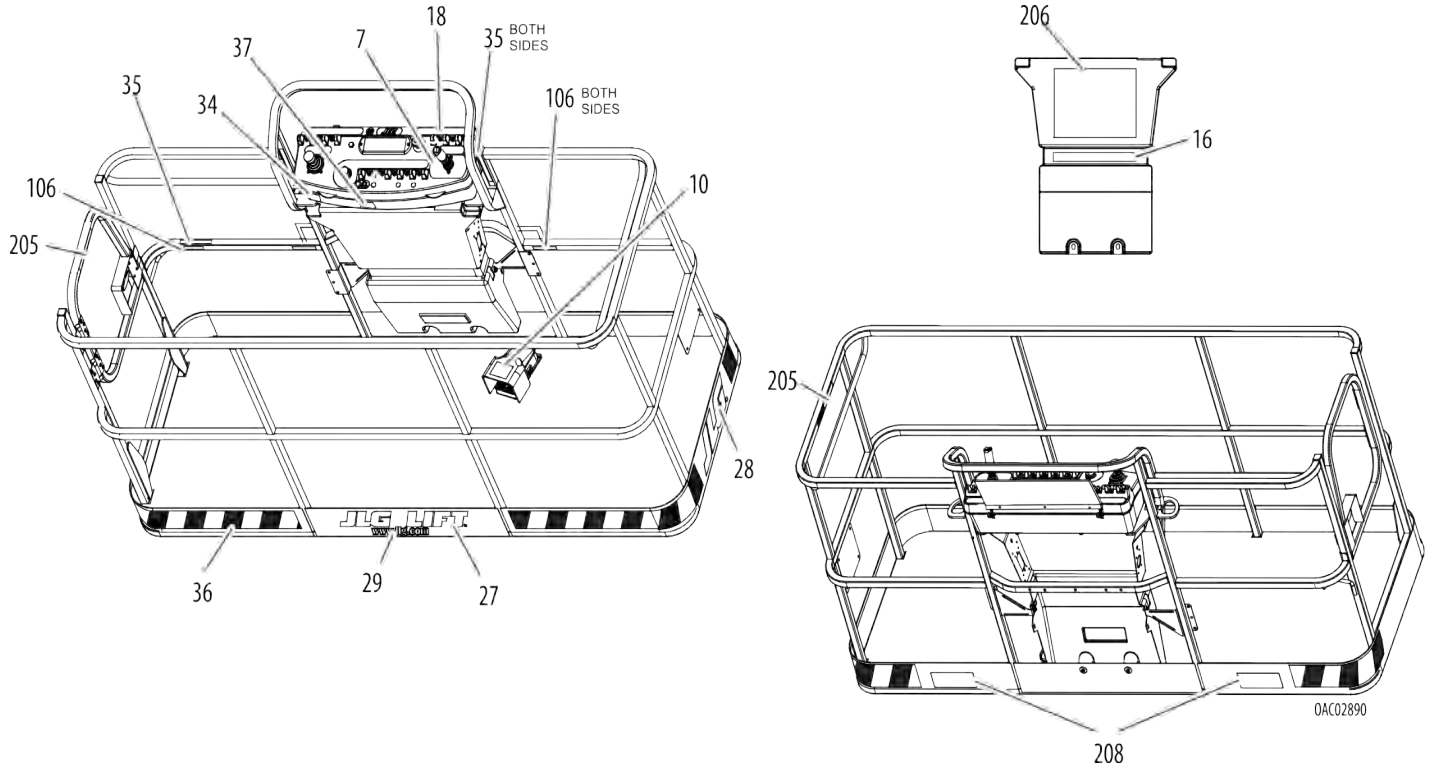

Figure 4-12. Decal Location Sheet 2 of 5



**Figure 4-13. Decal Location Sheet 3 of 5**

## SECTION 4 - MACHINE OPERATION

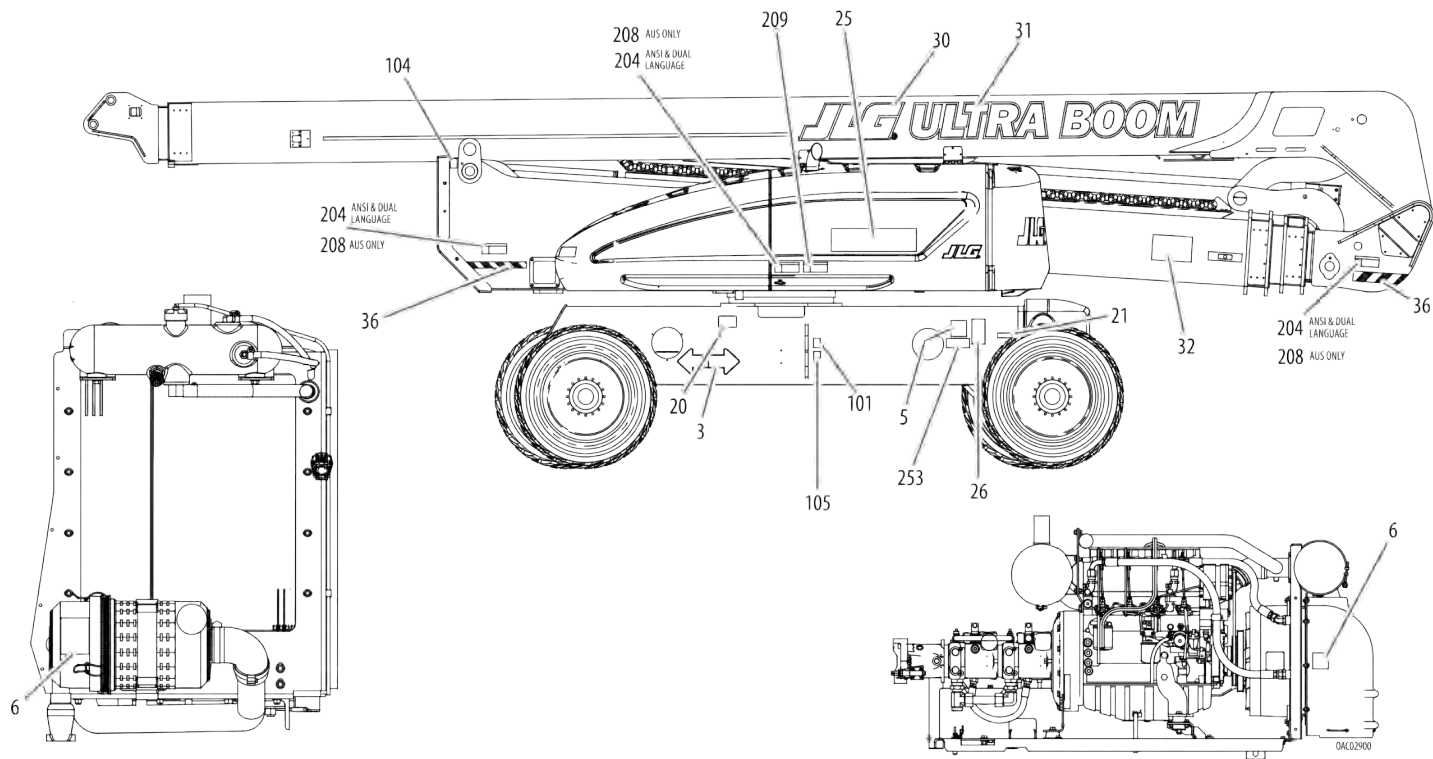
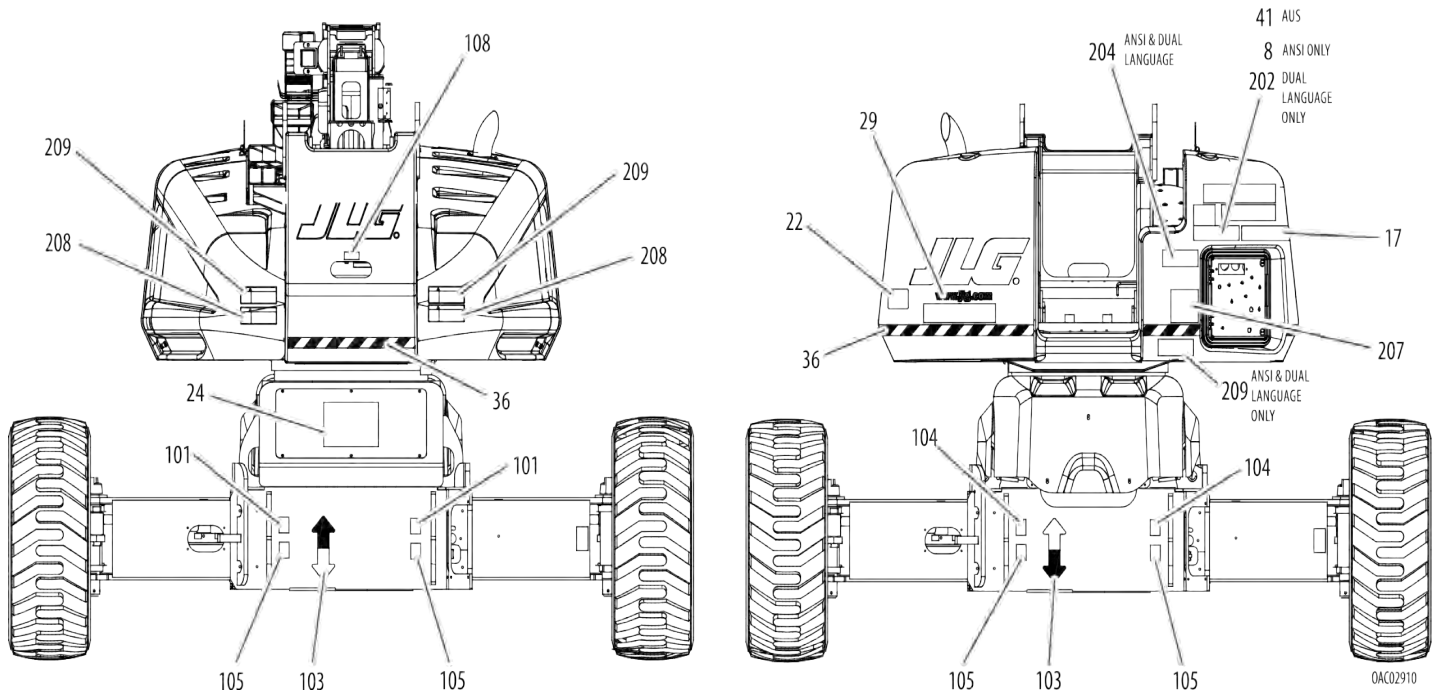

Figure 4-14. Decal Location Sheet 4 of 5



**Figure 4-15. Decal Location Sheet 5 of 5**

## SECTION 4 - MACHINE OPERATION

**Table 4-2. Decal Legend**

Item #	ANSI 1001243965-B	Korean 1001244205-B	Chinese 1001244206-B	Portuguese 1001244207-B	English/ Spanish 1001244208-B	French/English 1001243994-B	Australian 1001246611-A	Japan 1001244209-B
3	1701501	1701501	1701501	1701501	1701501	1701501	1701501	1701501
4	1701505	1701505	1701505	1701505	1701505	1701505	1701505	1701505
5	1702631	1702631	1702631	1702631	1702631	1702631	1702631	1702631
6	1704972	1706061	1706060	1706059	1706063	1706064	1706098	1706062
7	1705351	1705427	1705430	1705905	1705910	1705429	--	1705426
8	1705492	--	--	--	--	--	--	--
9	1705511	1705511	1705511	1705511	1705511	1705511	1705511	1705511
10	3252347	--	--	--	--	--	1705828	--
15	91403230	91403230	91403230	91403230	91403230	91403230	91403230	91403230
16	1001253048	1001253052	1001253054	1001253057	1001253059	1001253050	1706770	1001253061
17	1001253049	1001253053	1001253056	1001253058	1001253060	1001253051	1705468	1001253062
18	1001122611	1001122611	1001122611	1001122611	1001122611	1705174	1705174	1001122611
19	1001131269	--	--	--	--	1001131269	--	--
20	1001223055	1001224048	1001224050	1001224052	1001224049	1001223971	--	1001224053
21	1001223453	--	--	--	--	1001223453	--	--
22	3251813	--	3251813	3251813	3251813	3251813	1705515	3251813

Table 4-2. Decal Legend

Item #	ANSI 1001243965-B	Korean 1001244205-B	Chinese 1001244206-B	Portuguese 1001244207-B	English/ Spanish 1001244208-B	French/English 1001243994-B	Australian 1001246611-A	Japan 1001244209-B
23	1703483	1703483	1703483	1703483	1703483	1703483	1703483	1703483
24	1705838	1705838	1705838	1705838	1705838	1705838	1705838	1705838
25	1705840	1705840	1705840	1705840	1705840	1705840	1705840	1705840
26	1001253997	1001253997	1001253997	1001253997	1001253997	1001253997	1001253994	1001253997
27	1702774	1702774	1702774	1702774	1702774	1702774	1702774	1702774
28	1702773	1702773	1702773	1702773	1702773	1702773	1702773	1702773
29	1704885	1704885	1704885	1704885	1704885	1704885	1704885	1704885
30	1705864	1705864	1705864	1705864	1705864	1705864	1705864	1705864
31	1705865	1705865	1705865	1705865	1705865	1705865	--	1705865
32	1703959	1703959	1703959	1703959	1703959	1703959	1703959	1703959
34	1001231801	--	--	--	--	--	--	--
35	1703175	--	--	--	--	1703175	--	--
36	4420051	4420051	4420051	4420051	4420051	4420051	4420051	4420051
37	1001094055	1001094055	1001094055	1001094055	1001094055	1001094055	1001094055	1001094055
41	--	--	--	--	--	--	1001112551	--
101	1701499	1701499	1701499	1701499	1701499	1701499	1701499	1701499
102	1701509	1701509	1701509	1701509	1701509	1701509	1701509	1701509
103	1701529	1701529	1701529	1701529	1701529	1701529	1701529	1701529

## SECTION 4 - MACHINE OPERATION

**Table 4-2. Decal Legend**

Item #	ANSI 1001243965-B	Korean 1001244205-B	Chinese 1001244206-B	Portuguese 1001244207-B	English/ Spanish 1001244208-B	French/English 1001243994-B	Australian 1001246611-A	Japan 1001244209-B
104	1703811	1703811	1703811	1703811	1703811	1703811	1703811	1703811
105	1703814	1703814	1703814	1703814	1703814	1703814	1703814	1703814
106	1704277	1704277	1704277	1704277	1704277	1704277	1704277	1704277
107	1704412	1704412	1704412	1704412	1704412	1704412	1704412	1704412
108	3251243	3251243	3251243	3251243	3251243	3251243	--	3251243
202	--	1705503	1001117035	1705906	1705915	1705505	--	1705493
204	1703953	1703945	1703943	1705903	1703941	1703942	--	1703944
205	1702868	1705969	1001116846	1705967	1704001	1704000	--	--
206	1001231315	1001231317	1001231321	1001231319	1001231318	1001231316	1705921	1001231320
207	1705336	1705345	1001116849	1705896	1705917	1705347	1705822	1705344
208	1703804	1703951	1703949	1705898	1703947	1703948	1701518	1703950
209	1703805	1703939	1001116851	1705897	1703935	1703936	1705961	1703938
210	--	1703981	1703982	1705902	1703983	1703984	--	1703980



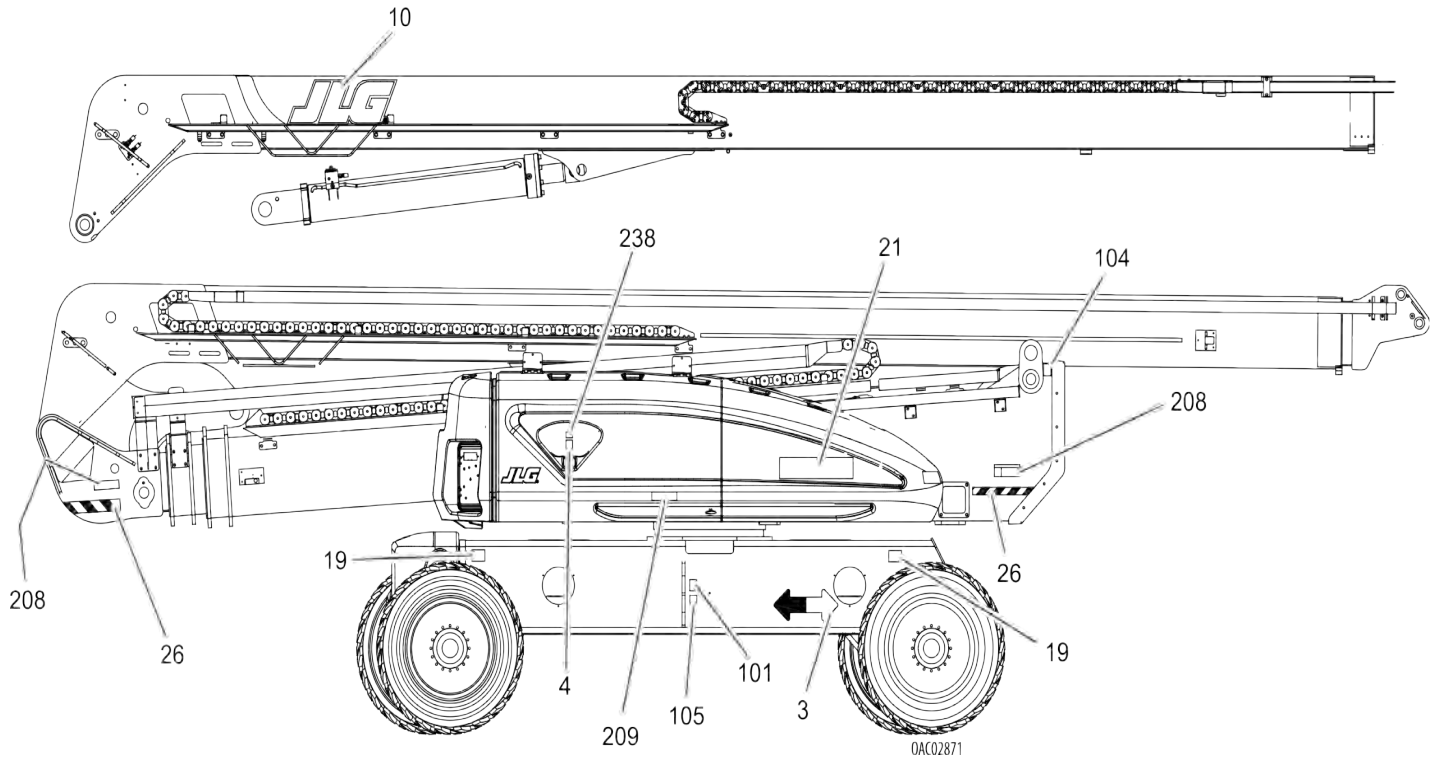

Figure 4-16. Decal Location - CE Only - Sheet 1 of 5

## SECTION 4 - MACHINE OPERATION

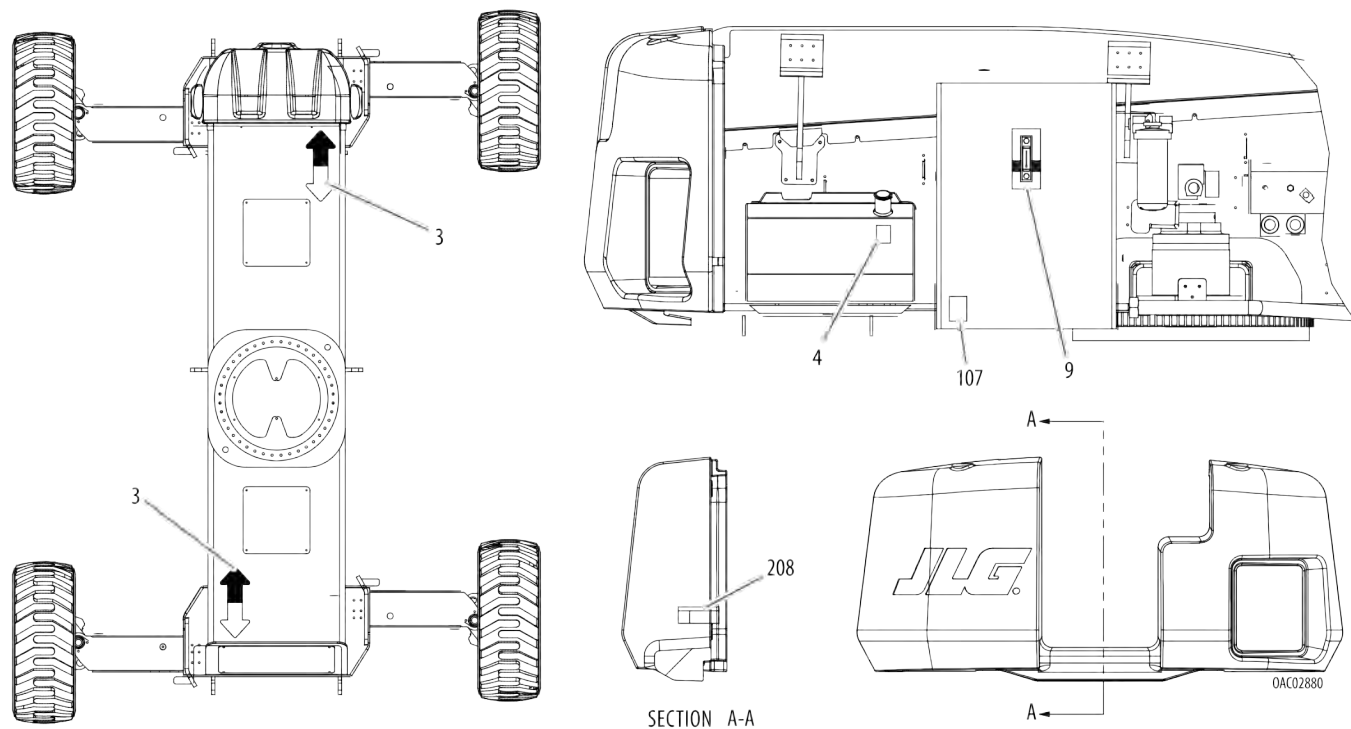

Figure 4-17. Decal Location - CE Only - Sheet 2 of 5

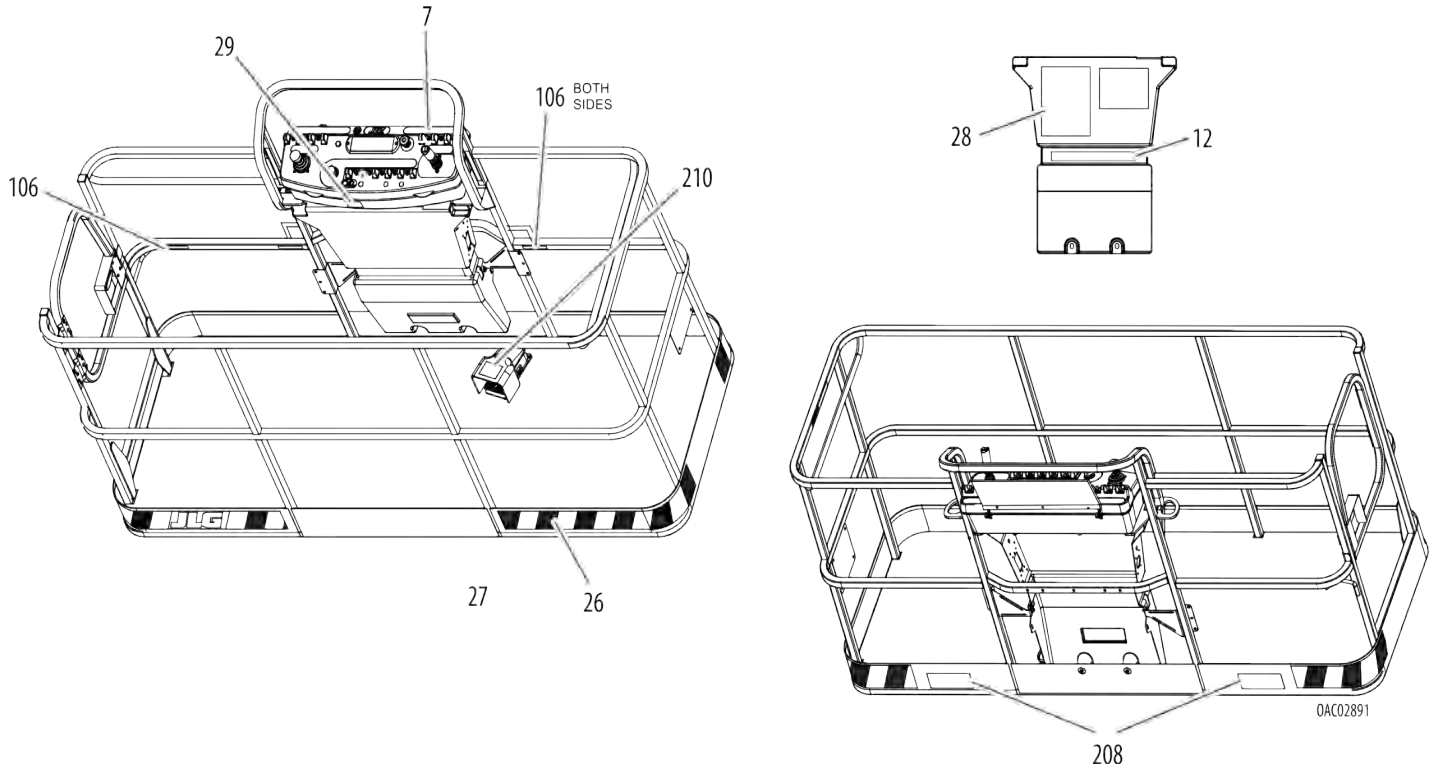

Figure 4-18. Decal Location - CE Only - Sheet 3 of 5

## SECTION 4 - MACHINE OPERATION

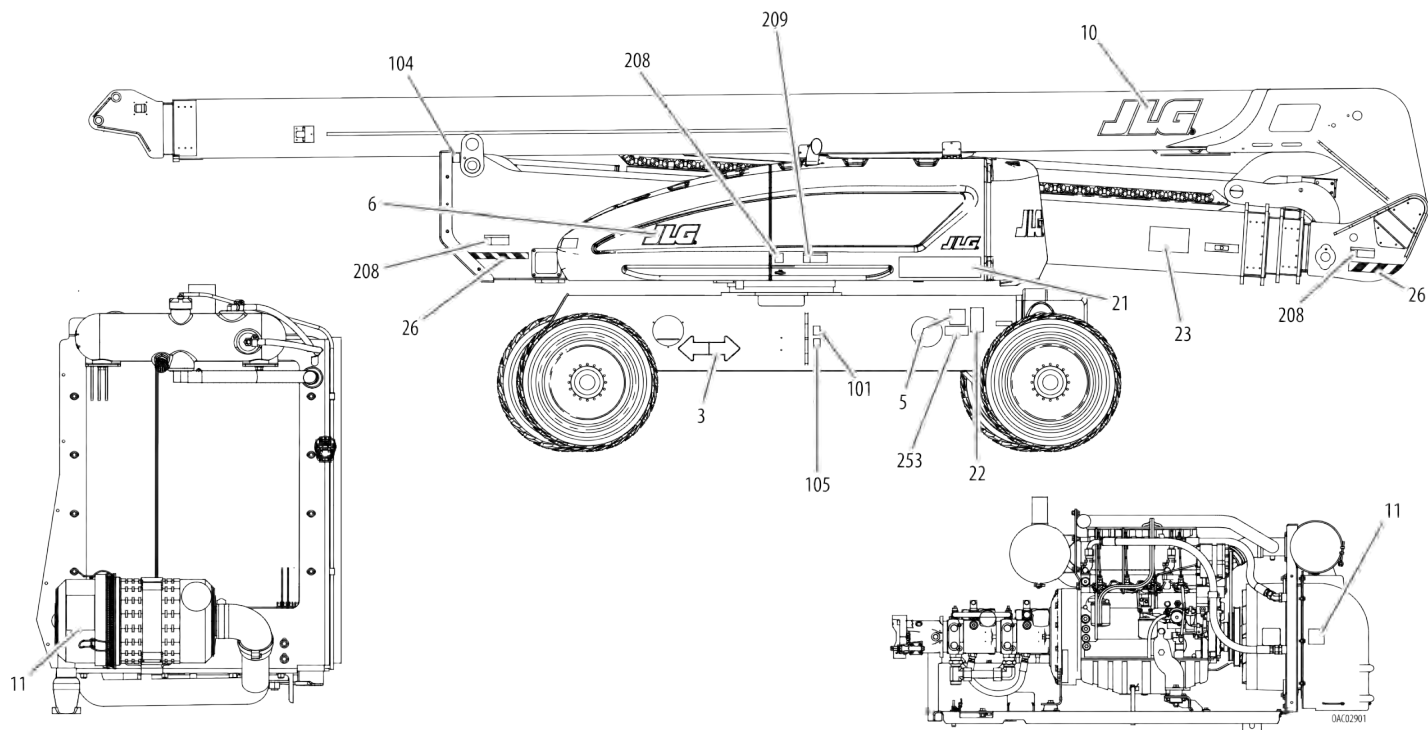

Figure 4-19. Decal Location - CE Only - Sheet 4 of 5

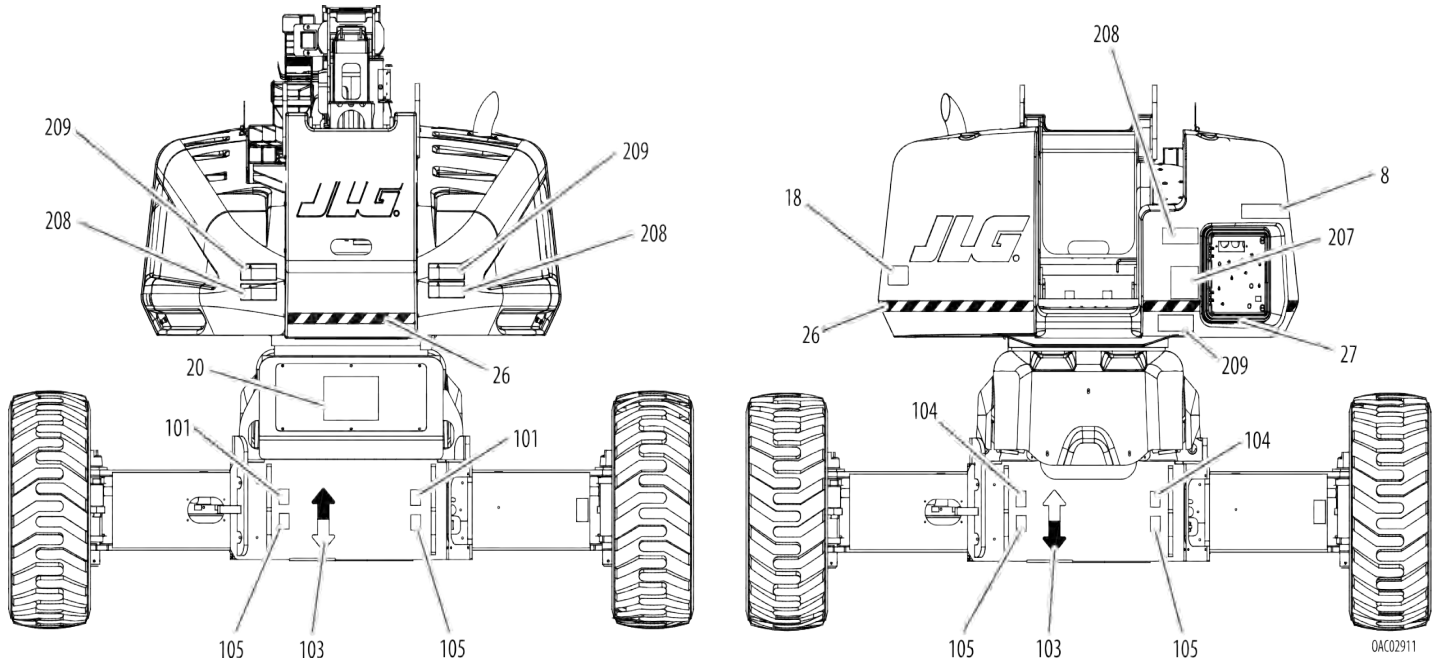

Figure 4-20. Decal Location - CE Only - Sheet 5 of 5

## SECTION 4 - MACHINE OPERATION

---

**Table 4-3. Decal Legend - CE Only**

<b>Item #</b>	<b>CE 1001246610-A</b>
3	1701501
4	1701505
5	1702631
6	1702773
7	1705174
8	1705468
9	1705511
10	1705864
11	1706098
12	1706770
17	91403230
18	1705515
19	1703483
20	1705838
21	1705840
22	1001253993
23	1703959

**Table 4-3. Decal Legend - CE Only**

<b>Item #</b>	<b>CE 1001246610-A</b>
26	4420051
27	1001197408
28	1001180696
29	1001094055
101	1701499
102	1701509
103	1701529
104	1703811
105	1703814
106	1704277
107	1704412
206	1705921
207	1705822
208	1701518
209	1705961
210	1705828

## **SECTION 5. EMERGENCY PROCEDURES**

### **5.1 GENERAL**

This section explains the steps to be taken in case of an emergency situation while operating.

### **5.2 INCIDENT NOTIFICATION**

JLG Industries, Inc. must be notified immediately of any incident involving a JLG product. Even if no injury or property damage is evident, the factory should be contacted by telephone and provided with all necessary details.

- USA: 877-JLG-SAFE (554-7233)
- EUROPE: (32) 0 89 84 82 20
- AUSTRALIA: (61) 2 65 811111
- E-mail: ProductSafety@JLG.com

Failure to notify the manufacturer of an incident involving a JLG Industries product within 48 hours of such an occurrence may void any warranty consideration on that particular machine.

### **NOTICE**

**FOLLOWING ANY ACCIDENT, THOROUGHLY INSPECT THE MACHINE AND TEST ALL FUNCTIONS FIRST FROM THE GROUND CONTROLS, THEN FROM THE PLATFORM CONTROLS. DO NOT LIFT ABOVE 3 M (10 FT.) UNTIL YOU ARE SURE THAT ALL DAMAGE HAS BEEN REPAIRED, IF REQUIRED, AND THAT ALL CONTROLS ARE OPERATING CORRECTLY.**

### **5.3 EMERGENCY OPERATION**

#### **Operator Unable to Control Machine**

IF THE PLATFORM OPERATOR IS PINNED, TRAPPED OR UNABLE TO OPERATE OR CONTROL MACHINE:

1. Other personnel should operate the machine from ground controls only as required.
2. Other qualified personnel on the platform may use the platform controls. **DO NOT CONTINUE OPERATION IF CONTROLS DO NOT FUNCTION PROPERLY.**
3. Cranes, forklift trucks or other equipment can be used to remove platform occupants and stabilize motion of the machine.

### **Platform or Boom Caught Overhead or Boom Movement Prevented by Boom Control System**

Lowering the boom onto an object or structure may cause the boom control system to prevent movement of the machine. This can include movement necessary to lift the boom off the object. Additionally, if the platform or boom becomes jammed or snagged in overhead structures, movement of the boom can be regained by doing the following:

1. Shut off the machine.
2. Rescue all people in the platform before freeing the machine. Personnel must be out of the platform before operating any controls on the machine.
3. Use cranes, forklifts, or other equipment to stabilize motion of the machine to prevent a tip over as required.
4. From the ground controls, use the Auxiliary Power System to carefully free the platform or boom from the object.
5. Once clear, restart the machine and return the platform to a safe position.
6. Inspect the machine for damage. If the machine is damaged or does not operate properly, turn off the machine immediately. Report the problem to the proper maintenance personnel. Do not operate the machine until it is declared safe for operation.

### **5.4 EMERGENCY TOWING PROCEDURES**

Towing this machine is prohibited, unless properly equipped. However, provisions for moving the machine have been incorporated. For specific procedures, refer to Section 4.



## 5.5 MACHINE SAFETY SYSTEM OVERRIDE (MSSO) (IF EQUIPPED)

The Machine Safety System Override (MSSO) is only to be used to retrieve an operator that is pinned, trapped, or unable to operate the machine and function controls are locked out from the platform due to a platform overload situation.



**NOTE:** *If the MSSO functionality is used, a fault code is set in the JLG Control System which must be reset by a qualified JLG Service Technician.*

**NOTE:** *No functional checks of the MSSO system are necessary. The JLG Control system will set a Diagnostic Trouble Code if the control switch is faulty.*

To operate the MSSO:

1. From the ground control console, place the Platform/ Ground Select switch in the Ground position.
2. Pull out the Power/Emergency Stop control.
3. Start the engine.
4. Press and hold the MSSO switch and the control switch for the desired function.

**SECTION 5 - EMERGENCY PROCEDURES**

---

## SECTION 6. ACCESSORIES

Table 6-1. Available Accessories

Accessory	Market						
	ANSI (USA Only)	ANSI	CSA	CE	AUS	Japan	China
Fall Arrest Platform (36" x 72")	√	√	√		√	√	√
Fall Arrest Platform (36" x 96")	√	√	√		√	√	√
Pipe Racks	√			√	√		
SkyCutter™	√	√	√			√	√
SkyGlazier™	√	√	√	√	√		√
SkyPower™ - 7.5 kW	√	√	√		√	√	√
Generator - 4 kW	√	√	√	√	√	√	√
SkyWelder™	√	√	√		√	√	√
Soft Touch	√	√	√	√	√	√	√
SkySense™	√	√	√	√	√	√	√
Bolt-On External Fall Arrest (36" x 72")	√	√	√			√	√
Bolt-On External Fall Arrest (36" x 96")	√	√	√			√	√

## SECTION 6 - ACCESSORIES

**Table 6-2. Options/Accessories Relationship Table**

ACCESSORY	REQUIRED ITEM	COMPATIBLE WITH (Note 1)	INCOMPATIBLE WITH	INTERCHANGABLE WITH (Note 2)
Pipe Racks		SkyPower™	Platform MMR**, Platform MTR*, Soft Touch, SkySense™	SkyCutter™, SkyGlazier™, SkyWelder™
SkyCutter™	SkyPower™	SkyWelder™	4' Platform, Pipe Racks, Platform MTR*, Soft Touch, SkySense™	SkyGlazier™
SkyGlazier™		SkyPower™	4' Platform, Pipe Racks, Platform MTR*, Soft Touch, SkySense™	SkyCutter™, SkyWelder™
SkyPower™		SkyCutter™, SkyGlazier™, SkyWelder™		
SkyWelder™	SkyPower™	SkyCutter™	4' Platform, Pipe Racks, Platform MTR*, Soft Touch, SkySense™	SkyGlazier™
Soft Touch		SkyPower™	Pipe Racks, SkyCutter™, SkyGlazier™, SkyWelder™, SkySense™	
SkySense™		SkyPower™	Pipe Racks, SkyGlazier™, SkyWelder™, Platform MMR**, Platform MTR*, Soft Touch	
<b>Note 1:</b> Any non-"Sky" accessory not listed under "INCOMPATIBLE WITH" is assumed to be compatible.				
<b>Note 2:</b> Can be used on same unit but not simultaneously.				
* Platform MTR = Platform Mesh to Top Rail; ** Platform MMR = Platform Mesh to Mid Rail				

**⚠ WARNING**

**INSTALLING OR REMOVING APPROVED ACCESSORIES OR CHANGING PLATFORM SIZE REQUIRES RECALIBRATION OF THE BOOM CONTROL SYSTEM (SEE SERVICE AND MAINTENANCE MANUAL).**

## **6.1 FALL ARREST PLATFORM**

**NOTE:** See the JLG External Fall Arrest System manual (PN 3128935) for more detailed information.

The external fall arrest system is designed to provide a lanyard attach point while allowing the operator to access areas outside the platform. Exit/enter the platform through the gate area only. The system is designed for use by one person.

Personnel must use fall protection at all times. A full body harness is required with lanyard not to exceed 6 ft (1.8 m) in length, that limits the maximum arrest force to 900 lb (408 kg) for the trans-fastener type and 1350 lb (612 kg) for the shuttle type fall arrest system.

## **Safety Precautions**

**⚠ WARNING**

**DO NOT OPERATE ANY MACHINE FUNCTIONS WHILE OUTSIDE THE PLATFORM. USE CAUTION WHEN ENTERING/EXITING THE PLATFORM AT ELEVATION.**

## 6.2 PIPE RACKS

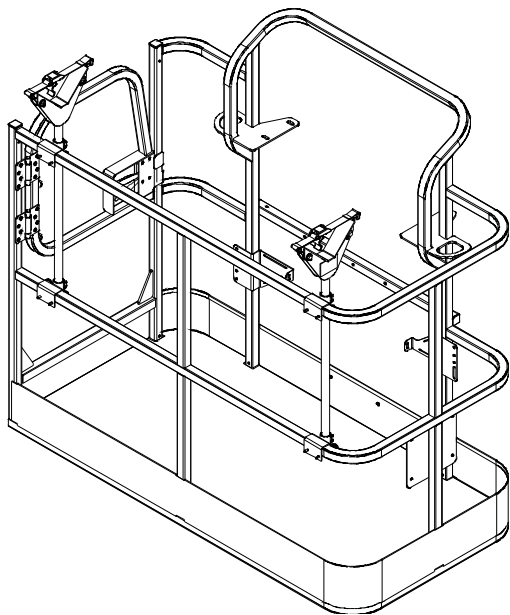

Pipe Racks provide a way to store pipe or conduit inside the platform in order to prevent rail damage and optimize platform utility. This accessory consists of two racks with adjustable straps to secure the load in place.

### Capacity Specifications (Australia Only)

Max. Capacity in Racks	Max. Platform Capacity (With Max. Weight in Racks)
80 kg	184 kg
Max. Length of Material in Racks: 6.0 m	
Min. Length of Material in Racks: 2.4 m	

### Safety Precautions

#### **⚠ WARNING**

REDUCE PLATFORM CAPACITY BY 100 LB (45.5 KG) WHEN INSTALLED.

#### **⚠ WARNING**

WEIGHT IN RACKS PLUS WEIGHT IN PLATFORM MUST NOT EXCEED RATED CAPACITY.

#### **NOTICE**

THE MAXIMUM LOAD IN THE RACKS IS 180 LB (80 KG) EVENLY DISTRIBUTED BETWEEN THE TWO RACKS.

#### **NOTICE**

THE MAXIMUM LENGTH OF MATERIAL IN RACKS IS 20 FT (6.1 M).

- Ensure no personnel are beneath the platform.
- Do not exit platform over rails or stand on rails.
- Do not drive machine without material secured
- Return racks to the stowed position when not in use.
- Use this option only on approved models.

## **Preparation and Inspection**

- Ensure racks are secured to the platform rails.
- Replace torn or frayed tie-down straps.

## **Operation**

1. To prepare racks for loading, remove locking pins, rotate each rack 90 degrees from stowed to working position, then secure with locking pins.
2. Loosen and remove tie-down straps. Place material on racks with weight evenly distributed between both racks.
3. Route the tie-down straps at each end across loaded material and tighten.
4. To remove material, loosen and remove tie-down straps, then carefully remove material from racks.

**NOTE:** *Reinstall tie-down straps across any remaining material before continuing machine operations.*

### 6.3 SKYCUTTER™

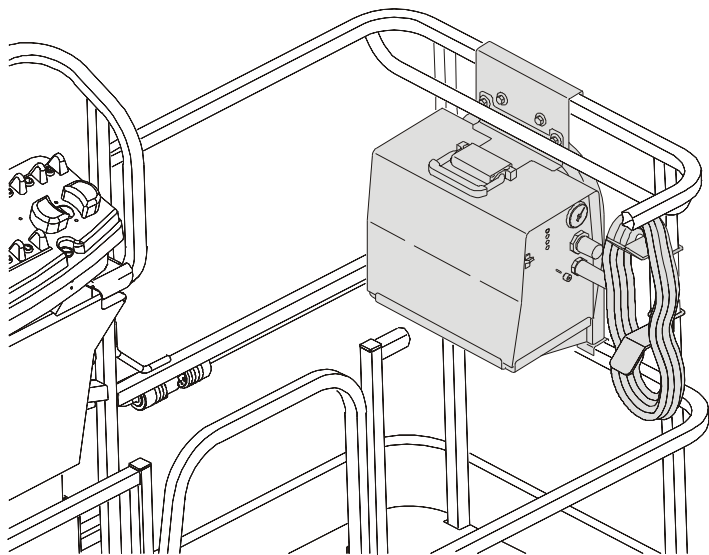

SkyCutter™ is capable of cutting up to a thickness of 3/8" metal. It can produce 27 A at 92 VDC at 35% duty cycle or 14 A at 92 VDC at 60% duty cycle. It receives power from the SkyPower™ system.

### Safety Precautions

#### **⚠ WARNING**

**DO NOT OVERLOAD PLATFORM.**

#### **⚠ WARNING**

**DE-RATE THE PLATFORM BY 70 LB (32 KG) WHEN PLASMA CUTTER IS IN PLATFORM.**

- Check for cracked welds and damage to plasma supports.
- Check for secure installation of cutter and bracket.
- Ensure no personnel are beneath platform.
- Do not exit platform over rails or stand on rails.
- Use this option only on approved models.
- Keep lanyard attached at all times.
- Use correct cutting settings.
- Do not use electrical cords without ground.
- Do not use electrical tools in water.
- Do not cut platform, or ground through the platform.
- Wear proper cutting apparel.
- Do not drive machine while connected to external air/gas sources.



## Accessory Ratings

Spec.	Rated Output	Amperes Input @ Rated Output, 60 Hz, 1-Phase	kVa/kW	Plasma Gas	Plasma Gas Flow/ Pressure	Rated Cutting Capacity @ 10 IPM	Max. OCV
120Volts ±10% (20A)	27 A @ 91VDC @ 20% Duty Cycle	28.8 max; 0.30*	3.4 kVa 3.2 kW	Air or Nitrogen Only @ 90 - 120 psi (621 - 827 kPa)	4.5 cfm (129 L/Min) @ 60 psi (414 kPa)	3/8 in (10 mm)	400VDC
120Volts ±10% (15A)	20 A @ 88VDC @ 35% Duty Cycle	20.6 max; 0.30*	2.5 kVa 2.3 kW				
240Volts ±10% (27A)	27 A @ 91VDC @ 35% Duty Cycle	13.9 max; 0.13*	3.3 kVa 3.0 kW				
*While idling.							

## Generator Output

Engine Speed of 1800 rpm +/- 10%.

### ANSI Specifications:

- 3-phase: 240 V, 60 Hz, 7.5 kW
- 1-phase: 240 V/120 V, 60 Hz, 6 kW

## Preparation and Inspection

- Connect ground clamp to metal being cut.
- Ensure there is a good ground connection.

## Operation

Start the engine, turn on the generator, then turn on the plasma cutter.

See the Miller Plasma Cutter Owner's Manual (PN 3128420) for more information.

6.4 SKYGLAZIER™

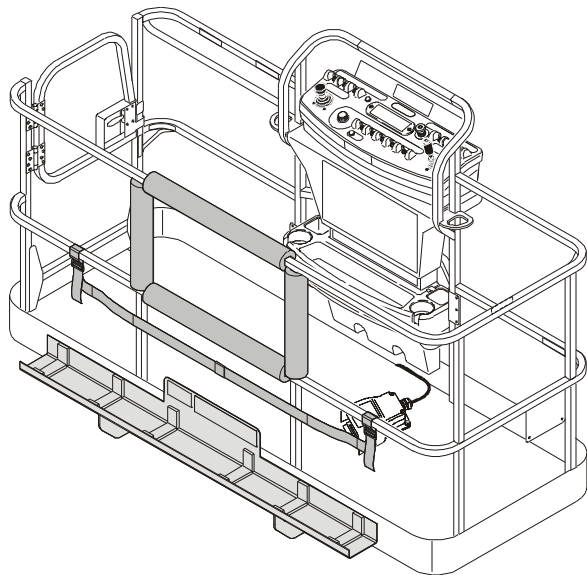

SkyGlazier™ allows glaziers to position panels efficiently. The glazier package consists of a tray that attaches the bottom of the platform. The panel rests on the tray and against top-rail of the platform, which is padded to prevent damage. SkyGlazier™ includes a strap to secure the panel to the platform rail.

Capacity Specifications

Capacity Zone *	Max. Tray Capacity	Max. Platform Capacity (With Max. Weight in Tray)
500 lb (227 kg)	150 lb (68 kg)	250 lb (113 kg)
550 lb (250 kg)	150 lb (68 kg)	250 lb (113 kg)
600 lb (272 kg)	150 lb (68 kg)	250 lb (113 kg)
750 lb (340 kg)	150 lb (68 kg)	440 lb (200 kg)
1000 lb (454 kg)	250 lb (113 kg)	500 lb (227 kg)

\* Refer to the capacity decals installed on the machine for capacity zone information.

**Required Platform Type:** Side-Entry

**Max. Dimensions of Panel:** 32 sq ft (3 sq m)

**⚠ WARNING**

**INSTALLING OR REMOVING APPROVED ACCESSORIES OR CHANGING PLATFORM SIZE REQUIRES RECALIBRATION OF THE BOOM CONTROL SYSTEM (SEE SERVICE AND MAINTENANCE MANUAL).**

## **Safety Precautions**

### **⚠ WARNING**

**ENSURE PANEL IS SECURED WITH STRAP.**

### **⚠ WARNING**

**DO NOT OVERLOAD TRAY OR PLATFORM. TOTAL MACHINE CAPACITY IS REDUCED WHEN TRAY IS INSTALLED.**

### **⚠ WARNING**

**WITH SKYGLAZIER™ INSTALLED, THE ORIGINAL PLATFORM CAPACITY RATINGS ARE REDUCED AS SPECIFIED IN THE CAPACITY SPECIFICATIONS TABLE. DO NOT EXCEED NEW PLATFORM CAPACITY RATINGS. REFER TO CAPACITY DECAL LOCATED ON TRAY.**

### **⚠ WARNING**

**AN INCREASE OF THE AREA EXPOSED TO THE WIND WILL DECREASE STABILITY. LIMIT PANEL AREA TO 32 SQ FT (3 SQ M).**

- Ensure no personnel are beneath platform.
- Do not exit platform over rails or stand on rails.
- Remove tray when not in use.
- Use this option only on approved models.

## **Preparation and Inspection**

- Check for cracked welds and damage to tray.
- Ensure tray is properly secured to platform.
- Ensure strap is not torn or frayed.

## **Operation**

1. Load SkyGlazier™ tray with panel.
2. Route the adjustable strap around the panel and tighten until secure.
3. Position panel to its desired location.

**6.5 SKYPOWER™ 7.5 KW AND GENERATOR 4 KW**

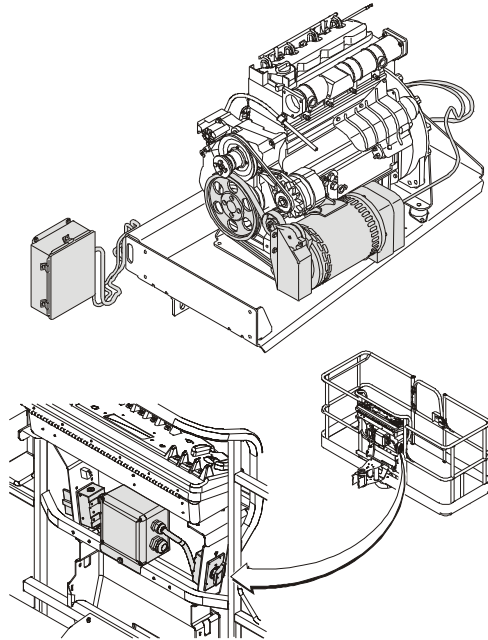

All power regulation components are located in a watertight box connected by cable to the generator. The generator supplies power when running at the specified speed with the power switch on (switch is located on platform). A two-pole 20 amp (4 kW) or three-pole, 30 amp (7.5 kW) circuit breaker protects the generator from overload.

**Output**

**SkyPower 7.5 kW Specifications:**

- 3-phase: 240 V, 60 Hz, 7.5 kW (Peak: 8.5 kW)
- 1-phase: 240 V/120 V, 60 Hz, 6 kW (Peak: 6 kW)

**Generator 4 kW Specifications:**

- 1-phase: 240 V/120 V, 60 Hz, 4 kW
- 1-phase: 230 V/115 V, 50 Hz, 4 kW

The SkyPower™ and generator systems supply AC power to the platform through an AC receptacle to run tools, lights, cutting, and welding equipment.

## Safety Precautions

### **⚠ WARNING**

**DO NOT OVERLOAD PLATFORM.**

- Ensure no personnel are beneath platform.
- This factory-installed option is available only on specified models.
- Keep lanyard attached at all times.
- Do not use electrical tools in water.
- Use correct voltage for tool being used.
- Do not overload circuit.

## Preparation and Inspection

- Ensure generator is secure.
- Check condition of belt and wiring.

## Operation

Start the engine, then turn on the generator.

See the Miller Generator Technical Manual (PN 3121677) for more information.

## 6.6 SKYWELDER™

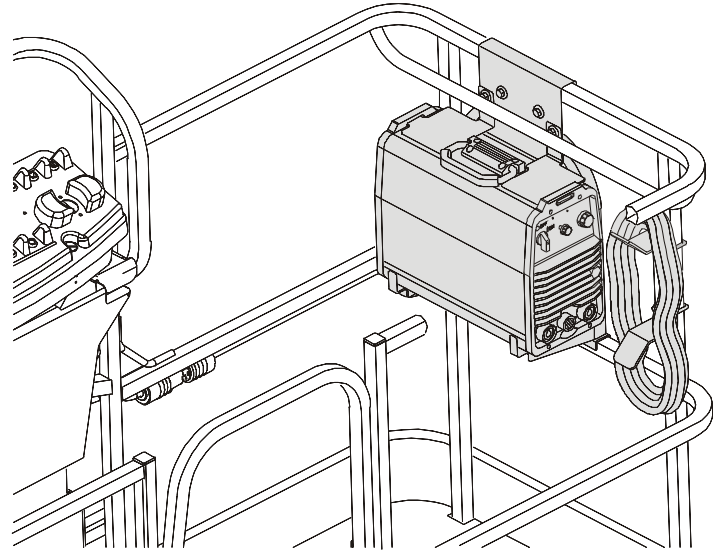

SkyWelder™ is capable of TIG and Stick welding, producing 200 Amps at 100% duty cycle or 250 Amps at 50% duty cycle. This accessory receives power from the SkyPower™ system.

## SECTION 6 - ACCESSORIES

### Accessory Ratings

Welding Mode	Input Power	Rated Output	Welding Amperage Range	Maximum Open Circuit Voltage	Amps Input At Rated Load Output (50/60 Hz)				
					230 V	460 V	575 V	kVa	kW
Stick (SMAW) TIG (GTAW)	3-phase	280 Amp at 31.2V, 35% Duty Cycle	5-250 A	79VDC	32	17	13	15.7	10
		200 Amp at 28V, 100% Duty Cycle			20	11	8	10.3	6.4
	1-phase	200 Amp at 28V, 50% Duty Cycle	5-200 A	79VDC	35	-----	-----	9.8	6.5
		150 Amp at 28V, 100% Duty Cycle			34	-----	-----	6.9	4.4

### Generator Output

Engine Speed of 1800 rpm +/- 10%.

#### ANSI Specifications:

- 3-phase: 240 V, 60 Hz, 7.5 kW
- 1-phase: 240 V/120 V, 60 Hz, 6 kW

### Welding Accessories

- 12 ft welding leads with clamp and stinger (stored in the platform)
- Fire extinguisher

## **Safety Precautions**

**⚠ WARNING**

**DO NOT OVERLOAD PLATFORM.**

**⚠ WARNING**

**DE-RATE THE PLATFORM BY 70 LB (32 KG) WHEN WELDER IS IN THE PLATFORM.**

- Check for cracked welds and damage to welder supports.
- Check for proper and secure installation of welder and bracket.
- Ensure no personnel are beneath platform.
- Do not exit platform over rails or stand on rails.
- Use this option only on approved models.
- Keep lanyard attached at all times.
- Ensure correct polarity of leads.

- Wear proper welding apparel.
- Use correct rod size and current settings.
- Do not use electrical cords without ground.
- Do not use electrical tools in water.
- Do not weld to the platform.
- Do not ground through the platform.
- Do not use a high frequency arc starter with TIG welder.

## **Preparation and Inspection**

- Connect ground clamp to metal being welded.
- Ensure there is a good ground connection and observe proper polarity.

## **Operation**

Start the engine, turn on the generator, then turn on the welder.

See the Miller Welder Owner's Manual (PN 3128957) for more information.

### 6.7 SOFT TOUCH

A padding kit is mounted to the platform rails and to a frame suspended below the platform. Limit switches deactivate platform functions when the padded framework contacts an adjacent structure. A button on the platform console allows override of the system.

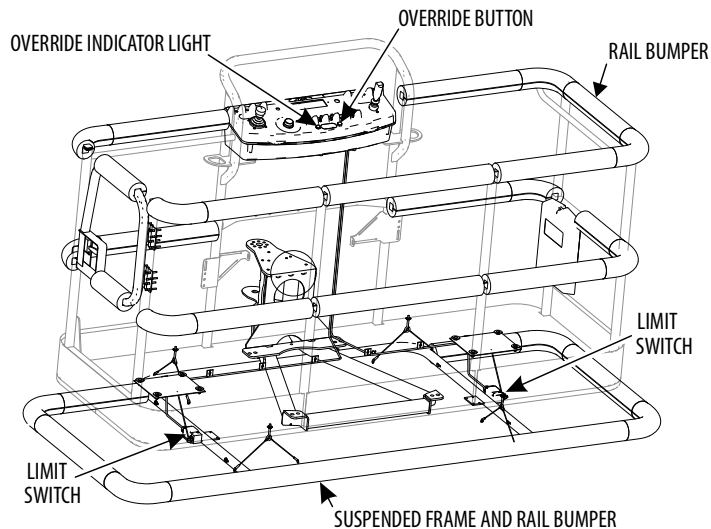

### 6.8 SKYSENSE™

#### **⚠ WARNING**

SKYSENSE IS NOT INTENDED TO REPLACE OR REDUCE THE NEED FOR THE OPERATOR TO BE AWARE OF THE ENVIRONMENT AROUND THE MACHINE. HAZARDS THAT WILL CAUSE SERIOUS INJURY OR DEATH MAY NOT BE PREVENTED OR REDUCED BY SKYSENSE. THE OPERATOR MUST ALWAYS LOOK IN THE DIRECTION OF TRAVEL, AVOID POWER LINES, AVOID OBSTACLES THAT COULD STRIKE THE MACHINE OR PERSONS IN THE PLATFORM, AND FOLLOW ALL INSTRUCTIONS, DECALS, AND OTHER WARNINGS PROVIDED WITH THIS MACHINE.

THE OPERATOR MUST NOT RELY ON SKYSENSE AS A SUBSTITUTE FOR FOLLOWING THE INSTRUCTIONS AND WARNINGS CONTAINED IN THE MANUALS AND PLACARDS PROVIDED WITH THIS MACHINE.

SKYSENSE IS INTENDED TO ASSIST THE OPERATOR. SKYSENSE MAY NOT DETECT CERTAIN OBJECTS DEPENDING ON SHAPE, TYPE OF MATERIAL, OR ORIENTATION OF THE OBJECT TO THE SENSORS. IT IS THE OPERATOR'S RESPONSIBILITY TO BE AWARE OF THEIR SURROUNDINGS AT ALL TIMES.

#### **⚠ WARNING**

DE-RATE THE PLATFORM BY 10 LB (4.5 KG) PER BAR WHEN INSTALLED ON THE PLATFORM (20 LB (9 KG) OR 30 LB (14 KG) TOTAL).



**NOTE:** *SkySense is not active when operating the machine from the ground controls.*

## Preparation and Inspection

Pre-Operation Inspection:

1. Inspect each of the SkySense tubes for dents, cracks, or other damage.
2. Inspect each SkySense sensor for any damage to the housing or sensor.

To test the SkySense system:

1. In an area free of obstructions, ensure the machine is on a smooth, firm surface within the limits of the maximum operating slope.
2. From the platform control console, elevate the boom until the bottom of the platform is at least 6 feet off the ground.
3. Continue to elevate the platform.
4. While elevating, hold your hand 6 inches to 12 inches above one of the upward facing sensors. The machine should stop, and the LED corresponding to that sensor (left LED for left sensor bar; right LED for right sensor bar; both LEDs for center sensor bar or overhead sensor) should be red.

5. Ensure the area below the platform is clear of obstructions and lower the platform. The machine should slow down, (SkySense Status LED will blink yellow with increasing frequency) and stop, (SkySense Status LED will be illuminated solid red) when the bottom of the platform is approximately 12 inches from the ground. The alarm should sound if it is not muted (refer to SkySense Alarm).
6. Recycle the footswitch and press the override button on the platform control console.
7. Continue to lower the platform. The machine should move in the elevated drive speed mode (SkySense Status LED will remain red).

**NOTE:** *The SkySense system will not stop machine operation while in Creep.*

### Operation

SkySense slows a machine's function to creep speed when it is a certain distance away from an object, known as the "warning zone." If the machine continues to approach the object and moves into the "stop zone," SkySense stops all machine functions.

For proportional functions activated by the joystick, the size of the warning zone varies based on the amount of joystick activation. The stop zone always activates at the same distance from the object regardless of the joystick's position.

If the function has reached the warning zone, normal drive speed will resume when a function is activated in the opposite direction. If the machine has reached the SkySense stop zone, release the function and recycle the footswitch to activate a function in the opposite direction.

SkySense is active during the following functions:

- Lift Up/Down (including jib functions)
- Platform Rotate (including jib rotate)
- Telescope Out
- Swing
- Reverse Drive

**NOTE:** During active DOS (Drive Orientation System), SkySense is active when driving in both forward and reverse directions.

There are two LED indicators on the platform control box that signal SkySense activity.

- **No LED:** Normal operation.
- **LED Flashing Yellow:** Machine is in SkySense warning zone and will reduce function speed to creep. Flash frequency correlates to proximity of object.
- **LED Red:** Machine is in SkySense stop zone and all machine functions will cease.
- **LED Flashing Red:** SkySense sensor is obstructed or damaged. Obstructions must be removed and proper function verified. Damaged sensors must be replaced.

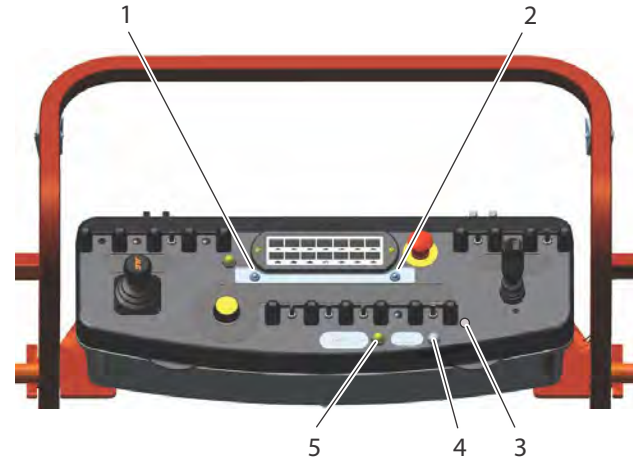

1. LED Indicator Light
2. LED Indicator Light
3. Alternate Mute Speaker Switch Position
4. Mute Speaker Switch
5. Override Button

**Figure 6-1. SkySense Platform Panel Indicators**

### SkySense Alarm

Activation of SkySense is signaled by an audible alarm and the LEDs on the platform console that indicate SkySense activity when reaching the warning or stop zones.

In the warning zone, the audible alarm will pulse and increase in frequency as the machine moves closer to the object. In the stop zone, the alarm will sound a continuous tone.

Additionally, when the machine is in the stop zone, the platform control panel audible alarm will sound. The system may be reset by recycling the footswitch.

The audible SkySense alarms can be muted by a switch on the platform control console, although LEDs will continue to light. The platform control panel alarm will sound when the machine enters the SkySense stop zone even when muted.

**NOTE:** *If the machine is equipped with headlights/tail lights or chassis illumination lights options AND the SkySense option, the Mute switch will be located in the alternate position (3). See Figure 6-1., SkySense Platform Panel Indicators.*

### Override Button

The yellow override button allows operators to bypass normal SkySense operation in order to move closer to an object in the stop zone.

When the operator overrides the SkySense via the override button to get closer to a work surface, the machine will maintain creep speed and flash the appropriate indicator color based on location in either the warning or stop zones.

**NOTE:** *Override is only required to be engaged if the operator desires to move the platform closer to an object that is in or entering the stop zone.*

**SKYGUARD OPERATION IS AFFECTED WHEN SKYSENSE IS INSTALLED ON A MACHINE. IF SKYSENSE ACTIVATION OCCURS PRIOR TO SKYGUARD ACTIVATION, SKYGUARD WILL ONLY CUT OUT FUNCTIONS IF ACTIVATED. IF SKYGUARD ACTIVATION OCCURS PRIOR TO SKYSENSE ACTIVATION, SKYGUARD WILL FUNCTION NORMALLY.**

## SkySense Coverage Areas

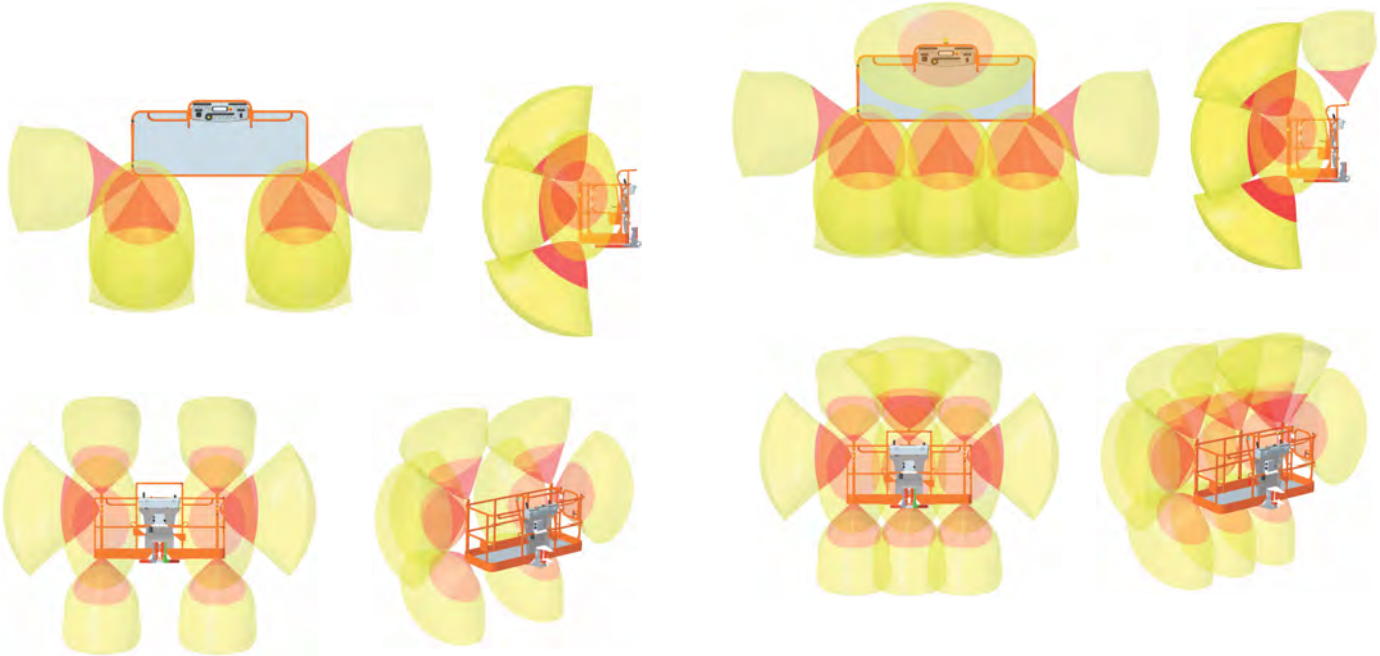

Level 1 (2-Bar)

Level 2 (3-Bar)

*Sensor Cones shown are approximations for reference only.*

### 6.9 BOLT-ON EXTERNAL FALL ARREST

The bolt-on external fall arrest system is designed to provide a lanyard attach point while allowing the operator to access areas outside the platform. Exit/Enter the platform through the gate area only. The system is designed for use by one person.

Personnel must use fall protection at all times. A full body harness is required with lanyard not to exceed 6 ft. (1.8 M) in length, that limits the maximum arrest force to 900 lb (408 kg).

External Fall Arrest System capacity is 310 lb (140 kg) - one (1) person maximum.

Do not move platform during use of the external fall arrest system.

#### **WARNING**

**DO NOT OPERATE ANY MACHINE FUNCTIONS WHILE OUTSIDE OF PLATFORM. BE CAREFUL WHEN ENTERING/EXITING THE PLATFORM AT ELEVATION.**

#### **WARNING**

**IF THE EXTERNAL FALL ARREST SYSTEM IS USED TO ARREST A FALL OR IS OTHERWISE DAMAGED, THE ENTIRE SYSTEM MUST BE REPLACED AND THE PLATFORM FULLY INSPECTED BEFORE RETURNING TO SERVICE. REFER TO THE SERVICE MANUAL FOR REMOVAL AND INSTALLATION PROCEDURES.**

#### **NOTICE**

**THE EXTERNAL FALL ARREST SYSTEM REQUIRES AN ANNUAL INSPECTION AND CERTIFICATION. THE ANNUAL INSPECTION AND CERTIFICATION MUST BE PERFORMED BY A QUALIFIED PERSON OTHER THAN THE USER.**

## Inspection Before Use

The external fall arrest system must be inspected before each use of the machine. Replace components if there are any signs of wear or damage.

Before each use, perform a visual inspection of the following components:

- Cable: Inspect cable for proper tension, broken strands, kinks, or any signs of corrosion.

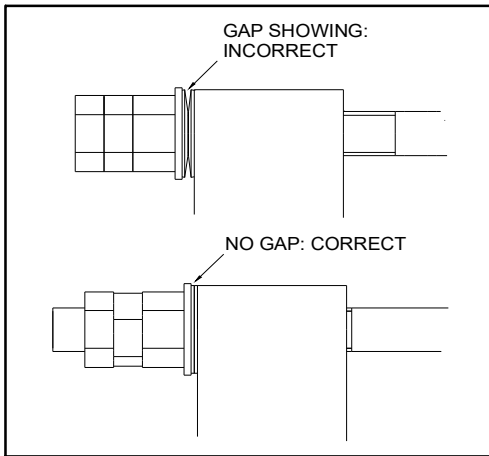

**Figure 6-1. Bolt-On External Fall Arrest Cable Tension**

- Fittings & Brackets: Ensure all fittings are tight and there are no signs of fractures. Inspect brackets for any damage.
- Attachment Ring: No cracks or signs of wear are acceptable. Any signs of corrosion requires replacement.
- Attaching Hardware: Inspect all attaching hardware to ensure there are no missing components and hardware is properly tightened.
- Platform Rails: No visible damage is acceptable.

## SECTION 6 - ACCESSORIES

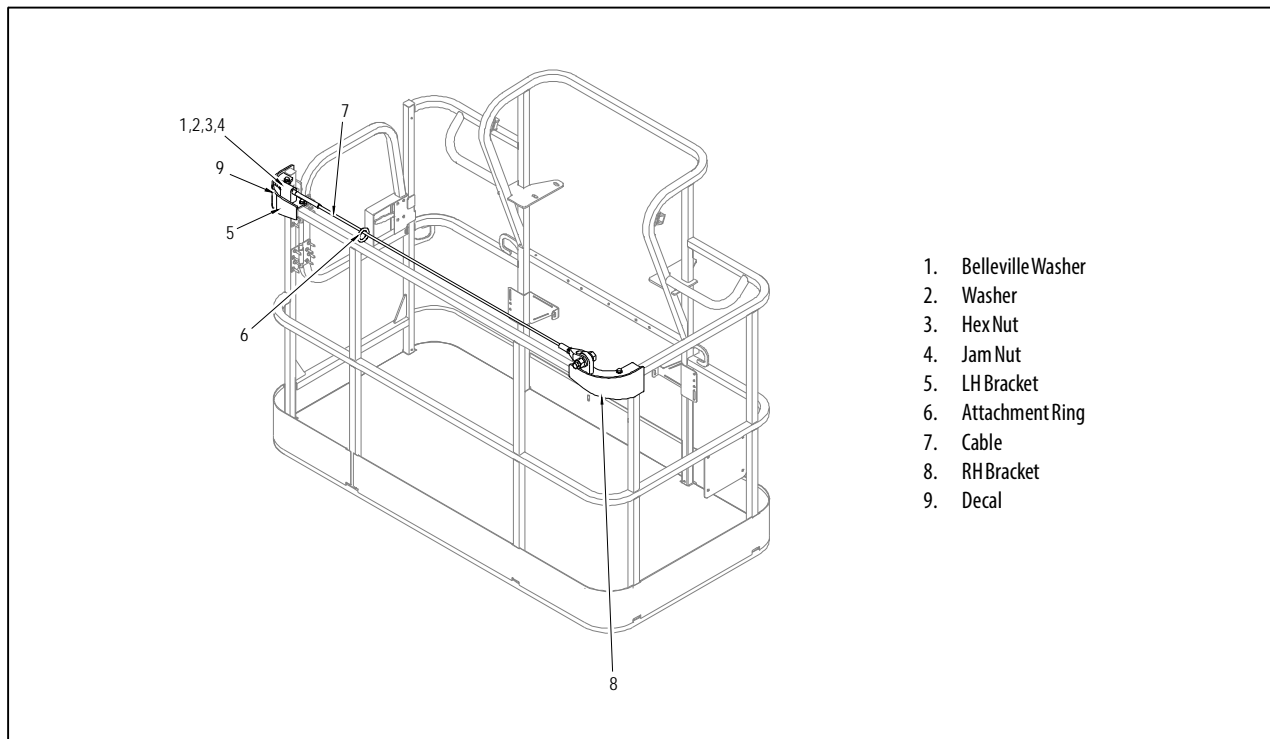

**Figure 6-2. Bolt-On External Fall Arrest System**



## SECTION 7. GENERAL SPECIFICATIONS & OPERATOR MAINTENANCE

### 7.1 INTRODUCTION

This section of the manual provides additional necessary information to the operator for proper operation and maintenance of this machine.

The maintenance portion of this section is intended as information to assist the machine operator to perform daily maintenance tasks only, and does not replace the more thorough Preventive Maintenance and Inspection Schedule included in the Service and Maintenance Manual.

#### Other Publications Available:

Service and Maintenance Manual ..... 31215058  
 Illustrated Parts Manual ..... 31215059

### 7.2 OPERATING SPECIFICATIONS AND PERFORMANCE DATA

**Table 7-1. Operating Specifications**

Maximum Work Load (Capacity) - ANSI Unrestricted Restricted	500 lb (227 kg) 1000 lb (454 kg)
Maximum Work Load (Capacity)- CE & Australia Unrestricted Restricted	500 lb (230 kg) 1000 lb (450 kg)
Maximum Operating Slope	5°
Max. Vertical Platform Height (Unrestricted)	125 ft. (38.1 m)
Max. Vertical Platform Height (Restricted)	125 ft. (38.1 m)
Max. Horizontal Platform Reach (Unrestricted)	63 ft. 2 in. (19.3 m)
Max. Horizontal Platform Reach (Restricted)	53 ft. 2 in. (16.2 m)
Up and Over Height	60 ft. 7 in. (18.5 m)
Main Boom Range (At Maximum Up & Over)	+75° / -55°
Maximum Boom Swing	360° Continuous

## SECTION 7 - GENERAL SPECIFICATIONS & OPERATOR MAINTENANCE

**Table 7-1. Operating Specifications**

JibPLUS	
Length	8ft. (2.44m)
Horizontal Motion	125° working, 210° stowed
Vertical Motion	130° (+75/-55)
Max. Hydraulic System Pressure	4600 psi (317 Bar)
Maximum Wind Speed	28 mph (12.5 m/s)
Maximum Manual Force	400 N
Electrical System Voltage	12 Volts
Max Tire Load	23,700 lb (10750 kg)
Maximum Platform Rotation	±90°
Maximum Travel Grade With boom in stowed position (Gradeability)	45%
Maximum Travel Grade With boom in stowed position (Side Slope)	5°
Turning Radius (Axles Retracted)	
Outside	22 ft. 6 in. (6.8 m)
Inside	14 ft. 5 in. (4.4 m)
Turning Radius (Axles Extended)	
Inside	8ft. (2.4 m)
Outside	19ft. 4in. (5.9 m)
Max Tire Load	23700 lb (10750 kg)
Max Ground Bearing Pressure	100 psi (7.03 kg/cm <sup>2</sup> )

**Table 7-1. Operating Specifications**

Maximum Drive Speed	
Stowed	3.25 mph (5.2 km/h)
Elevated	0.75 mph (1.2 km/h)
Gross Machine Weight	
Platform Empty	44,000 lb (19,958 kg)
Platform Empty w/ Skypower	44,215 lb (20,056 kg)
Ambient (Operating) Temperature	See Figures 7-1. through 7-4.

**Dimensional Data**

**Table 7-2. Dimensional Data**

Overall Width	
Axles Retracted	8ft. 2in. (2.49 m)
Axles Extended	12ft. 6in. (3.8 m)
Stowed Height	10ft. (3.05 m)
Stowed Length (Transport Mode)	37ft. 7 in. (11.46 m)
Stowed Length (Working Mode)	47ft. 6 in. (14.48 m)
Wheelbase	12ft. 6in. (3.81 m)
Tailswing	
Tower Up	7ft. (2.13 m)
Tower Down	11ft. 3 in. (3.43 m)
Oscillating Axle	±6in. (0.15 m)
Ground Clearance (Axle)	12 in. (30.4 cm)
Ground Clearance (Chassis)	25.5 in. (64.7 cm)

**Capacities**

**Table 7-3. Capacities**

Hydraulic Tank	53.3 gallons (201.7 liters)
Fuel Tank	31 gallons (117 liters)
Hydraulic System	65.4 gallons (247.5 liters)
Drive Hub	
Bonfiglioli	2.1 quarts (2 liters) ± 10%
Reggiana Riduttori	0.5 quarts (0.5 liters) ± 10%

## SECTION 7 - GENERAL SPECIFICATIONS & OPERATOR MAINTENANCE

### Tires

**Table 7-4. Tire Specifications**

Size	445/50D710
Load Range	J
Ply Rating	18
Foam Fill	Polyurethane HD (55 Durometer) Foam
Diameter	46.45 in. (117.9 cm)
Width	18 in. (45.7 cm)
Rim Size	15x28
Tire & Wheel Weight	867 lb (393 kg)
Max Tire Load	23,700 lb (10750 kg)
Size	445/65-24
Type	Solid
Diameter	45.3 in. (115.1 cm)
Width	17.3 in. (43.9 cm)
Rim Size	12.00-24
Tire & Wheel Weight	960 lb (435.4 kg)
Max Tire Load	23,700 lb (10750 kg)

### Engine Data - Deutz 2011

**Table 7-5. Deutz TD2011L4 Specifications**

Type	Liquid Cooled
Number of Cylinders	4
Bore	3.7 in. (94 mm)
Stroke	4.4 in. (112 mm)
Total Displacement	190 cu. in. (3108 cm <sup>3</sup> )
Compression Ratio	17.5
Firing Order	1-3-4-2
Output	75hp (56 kW)
Oil Capacity	
Cooling System	5 Quarts (4.5 L)
w/Filter	11 Quarts (10.5 L)
Total Capacity	16 Quarts (15 L)
Average Fuel Consumption	1.1 gph (4.1 lph)
Idle Engine RPM	1200
Mid Engine RPM	1800
High Engine RPM	2475

## SECTION 7 - GENERAL SPECIFICATIONS & OPERATOR MAINTENANCE

### Engine Data - Deutz TCD2.9L4

Table 7-6. Deutz TCD2.9L4 Specifications

Type	Liquid Cooled
Number of Cylinders	4
Bore	3.6 in. (92 mm)
Stroke	4.3 in. (110 mm)
Total Displacement	178 cu. in. (2925 cm <sup>3</sup> )
Firing Order	1-3-4-2
Output	74.2hp (55.4 kW)
Oil Capacity	2.4Gallon (8.9L)
Coolant Capacity (System)	3.2Gallon (12.1L)
Average Fuel Consumption	1.2 gph (4.1 lph)
Min. Low Engine RPM	1200
Mid Engine RPM	1800
Max. High Engine RPM	2500

### Engine Data - Caterpillar

Table 7-7. Caterpillar 3.4T

Type	Liquid Cooled, Antifreeze
Number of Cylinders	4
Bore	3.7 in. (94 mm)
Stroke	4.7 in. (120 mm)
Total Displacement	201 cu. in. (3294 cm <sup>3</sup> )
Compression Ratio	19.5:1
Firing Order	1-3-4-2
Output	73.7hp (55 kW)
Oil Capacity	10.5 Quarts (10L)
Average Fuel Consumption	1.36 gph (5.14 lph)
Idle Engine RPM	1200
Mid Engine RPM	1800
High Engine RPM	2475

## SECTION 7 - GENERAL SPECIFICATIONS & OPERATOR MAINTENANCE

### Hydraulic Oil

**Table 7-8. Hydraulic Oil Specifications**

Hydraulic System Operating Temperature Range	S.A.E. Viscosity Grade
+0° to +180°F (-18° to +83°C)	10W
+0° to +210°F (-18° to +99°C)	10W-20, 10W30
+50° to +210°F (+10° to +99°C)	20W-20

**NOTE:** Hydraulic oils must have anti-wear qualities at least to API Service Classification GL-3, and sufficient chemical stability for mobile hydraulic system service. JLG Industries recommends Standard UTTO, which has an SAE viscosity index of 152.

**NOTE:** When temperatures remain consistently below 20 degrees F. (-7 degrees C.), JLG Industries recommends the use of Mobil DTE13.

Aside from JLG recommendations, it is not advisable to mix oils of different brands or types, as they may not contain the same required additives or be of comparable viscosities.

**Table 7-9. Mobilfluid 424 Specs**

SAE Grade	10W30
Gravity, API	29.0
Density, Lb/Gal. 60°F	7.35
Pour Point, Max	-46°F (-43°C)
Flash Point, Min.	442°F (228°C)
Viscosity	
Brookfield, cP at -18°C	2700
at 40°C	55 cSt
at 100°C	9.3 cSt
Viscosity Index	152

**SECTION 7 - GENERAL SPECIFICATIONS & OPERATOR MAINTENANCE**

**Table 7-10. Mobil DTE 10 Excel 32 Specs**

ISO Viscosity Grade	#32
Specific Gravity	0.877
Pour Point, Max	-40°F (-40°C)
Flash Point, Min.	330°F (166°C)
<b>Viscosity</b>	
at 40°C	33 cSt
at 100°C	6.6 cSt
at 100°F	169 SUS
at 210°F	48 SUS
cp at -20°F	6,200
Viscosity Index	140

**Table 7-11. UCon Hydrolube HP-5046**

<b>Type</b>	<b>Synthetic Biodegradable</b>
Specific Gravity	1.082
Pour Point, Max	-58°F (-50°C)
pH	9.1
<b>Viscosity</b>	
at 0°C (32°F)	340 cSt (1600 SUS)
at 40°C (104°F)	46 cSt (215 SUS)
at 65°C (150°F)	22 cSt (106 SUS)
Viscosity Index	170

## SECTION 7 - GENERAL SPECIFICATIONS & OPERATOR MAINTENANCE

**Table 7-12. Exxon Univis HVI 26 Specs**

Specific Gravity	32.1
Pour Point	-76°F (-60°C)
Flash Point	217°F (103°C)
<b>Viscosity</b>	
at 40°C	25.8 cSt
at 100°C	9.3 cSt
Viscosity Index	376
<b>NOTE:</b> <i>Mobil/Exxon recommends that this oil be checked on a yearly basis for viscosity.</i>	

**Table 7-13. Mobil EAL H 46 Specs**

Type	Synthetic Biodegradable
ISO Viscosity Grade	46
Density at 15°C	.874
Pour Point	-49°F (-45°C)
Flash Point	500°F (260°C)
Operating Temp.	-20 to 200°F (-29 to 93°C)
Weight	7.64 lb/gal (0.9 kg/L)
<b>Viscosity</b>	
at 40°C	48.8 cSt
at 100°C	7.8 cSt
Viscosity Index	145



**Table 7-14. Mobil EAL 46 Specs**

Type	Synthetic Biodegradable
ISO Viscosity Grade	46
Density at 15° C	.93
Pour Point	-27°F (-33°C)
Flash Point	568°F (298°C)
Operating Temp.	-20 to 200°F (-29 to 93°C)
Weight	7.64 lb/gal (0.9 kg/L)
Viscosity	
at 40° C	43.3 cSt
at 100° C	7.7 cSt
Viscosity Index	149

## Major Component Weights

**Table 7-15. Component Weights**

Component	Pounds	Kilograms
Tire & Wheel	867	393
Drive Hub & Motor	275.5	123
Engine Assembly	1275	579
Main Boom	5186	2357
Tower Boom	6990	3173
Tower Telescope Cylinder	915	415
Axle Oscillation Cylinder	74	34
Axle Extend Cylinder	92	42
Level Cylinder	89	40
Platform 36 x 96	245	111
Platform 36 x 72	195	89
Counterweight *	3320	1506
* For actual weight, see stamping on counterweight		

# SECTION 7 - GENERAL SPECIFICATIONS & OPERATOR MAINTENANCE

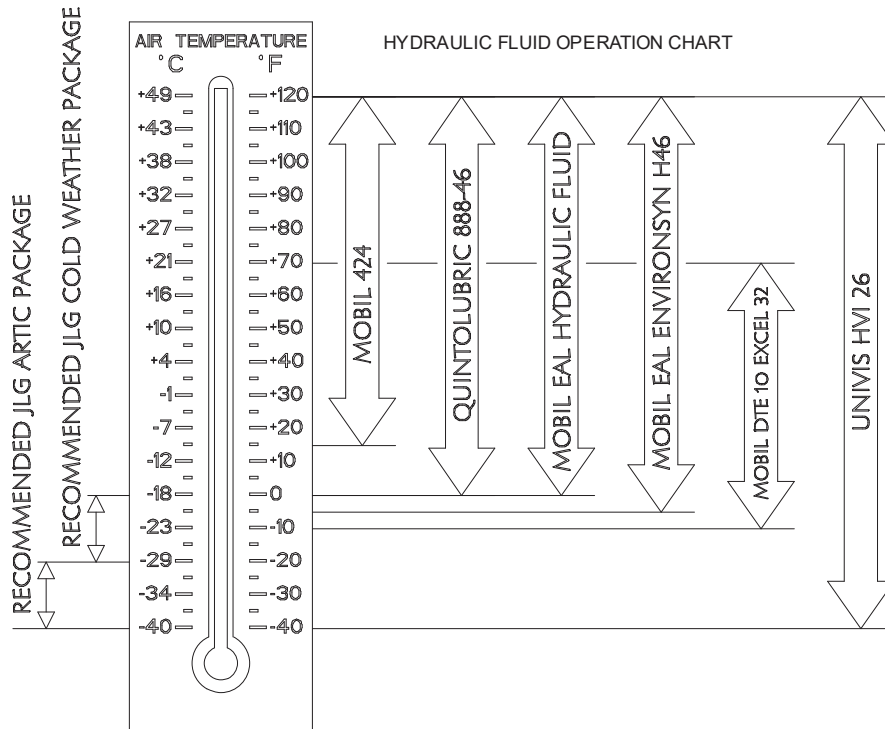

**NOTICE:**

MACHINE OPERATION USING NON-JLG APPROVED HYDRAULIC FLUIDS OR OPERATION OUTSIDE OF THE TEMPERATURE BOUNDARIES OUTLINED IN THE "HYDRAULIC FLUID OPERATION CHART" MAY RESULT IN PREMATURE WEAR OR DAMAGE TO COMPONENTS OF THE HYDRAULIC SYSTEM.

**Figure 7-1. Hydraulic Oil Operation Chart - Sheet 1 of 2**

## SECTION 7 - GENERAL SPECIFICATIONS & OPERATOR MAINTENANCE

Fluid	Properties		Base				Classifications		
	Viscosity at 40° C (cSt, Typical)	Viscosity Index	Mineral Oils	Vegetable Oils	Synthetic	Synthetic/Polyol Esters	Readily Biodegradable*	Virtually Non-toxic**	Fire Resistant***
Mobilfluid 424	55	145	X						
Mobil DTE 10 Excel 32	32	164	X					X	
Univis HVI 26	26	376	X						
Mobil EAL Hydraulic Oil	47	176		X			X	X	
Mobil EAL EnviroSyn H46	49	145			X		X	X	
Quintolubric 888-46	50	185				X	X	X	X

\* Readily biodegradable classification indicates one of the following:

CO2 Conversion > 60% per EPA 560/6-82-003

CO2 Conversion > 80% per CEC-L-33-A-93

\*\* Virtually Non-toxic classification indicates an LC50 > 5000 ppm per OECD 203

\*\*\* Fire Resistant classification indicates Factory Mutual Research Corp. (FMRC) Approval

41507-00 B

**Figure 7-2. Hydraulic Oil Operation Chart - Sheet 2 of 2**

## SECTION 7 - GENERAL SPECIFICATIONS & OPERATOR MAINTENANCE

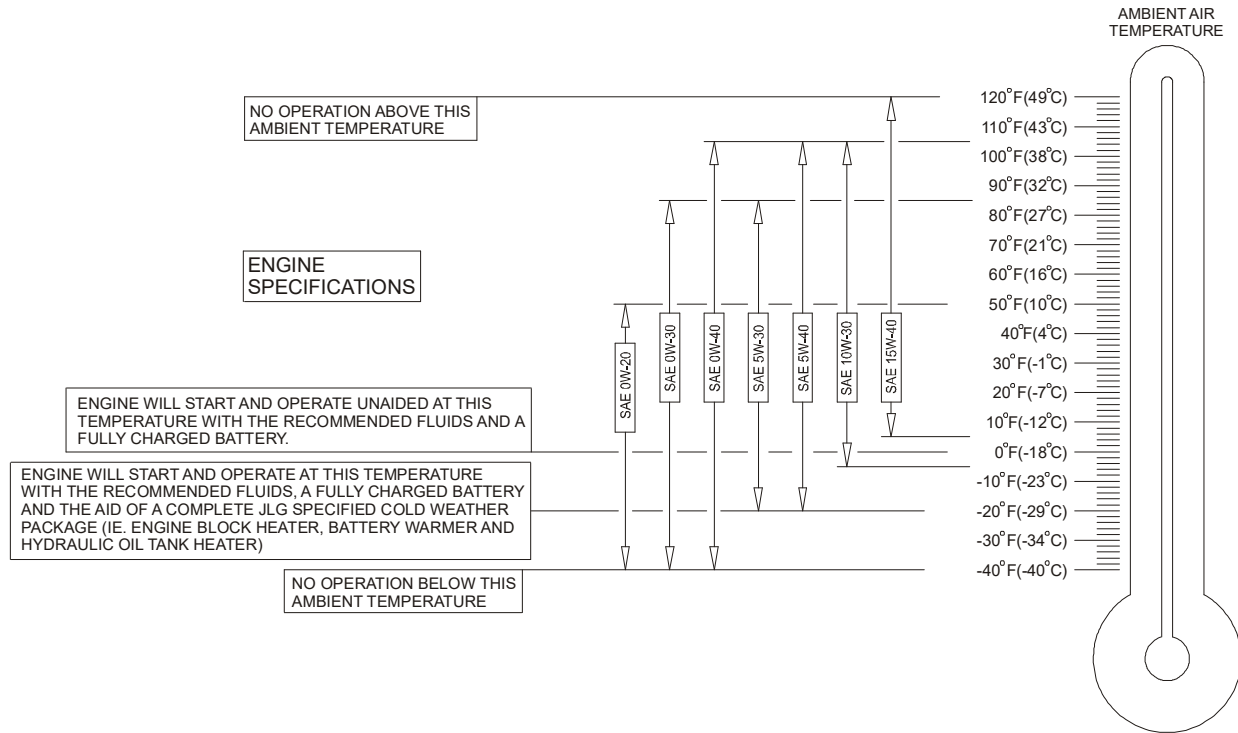

**Figure 7-3. Engine Operating Temperature Specifications - Caterpillar - Sheet 1 of 2**

## SECTION 7 - GENERAL SPECIFICATIONS & OPERATOR MAINTENANCE

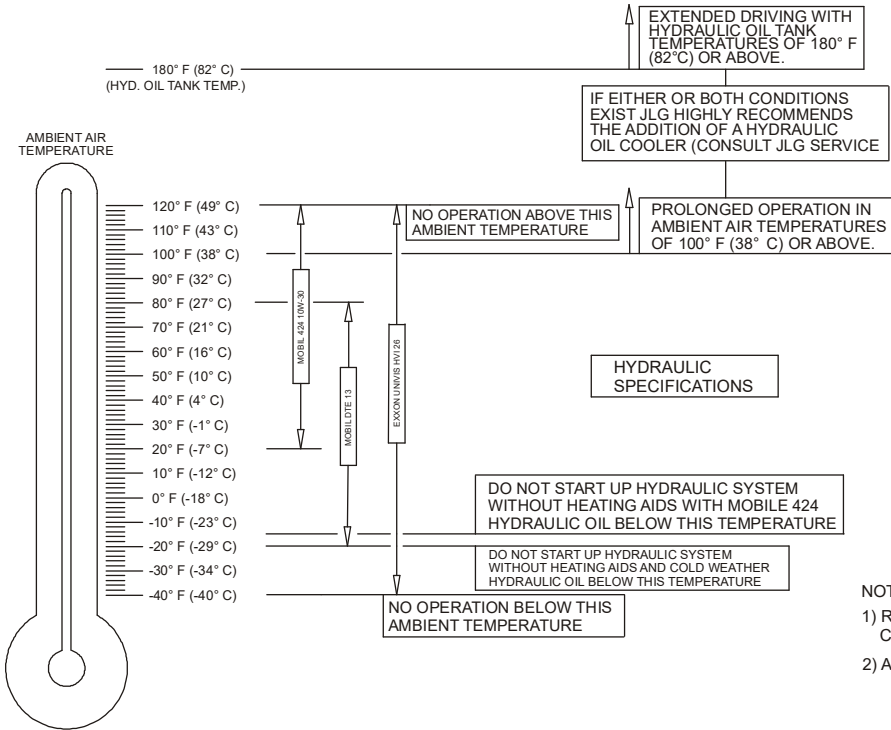

**NOTE:**

- 1) RECOMMENDATIONS ARE FOR AMBIENT TEMPERATURES CONSISTENTLY WITHIN SHOWN LIMITS
- 2) ALL VALUES ARE ASSUMED TO BE AT SEA LEVEL.

4150548-E

**Figure 7-4. Hydraulic System Operating Temperature Specifications - Caterpillar - Sheet 2 of 2**

## SECTION 7 - GENERAL SPECIFICATIONS & OPERATOR MAINTENANCE

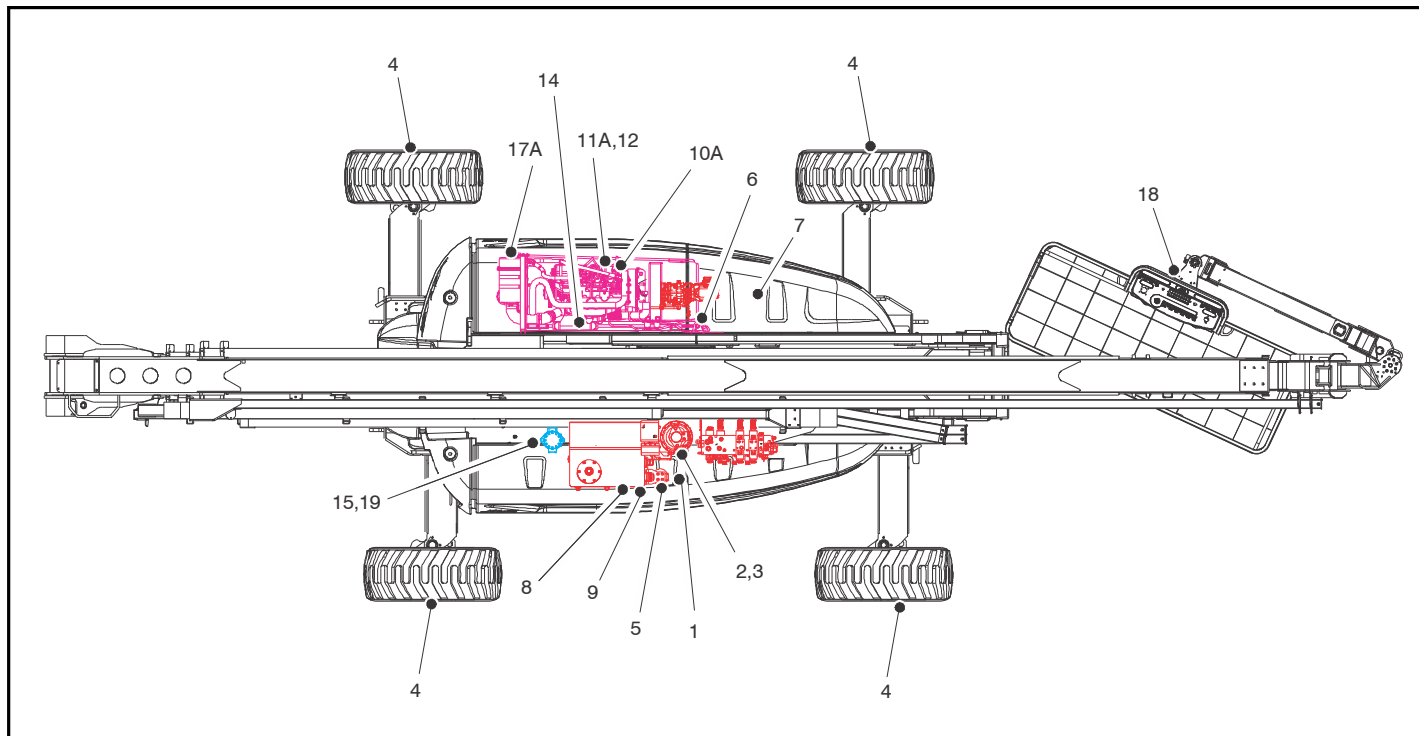
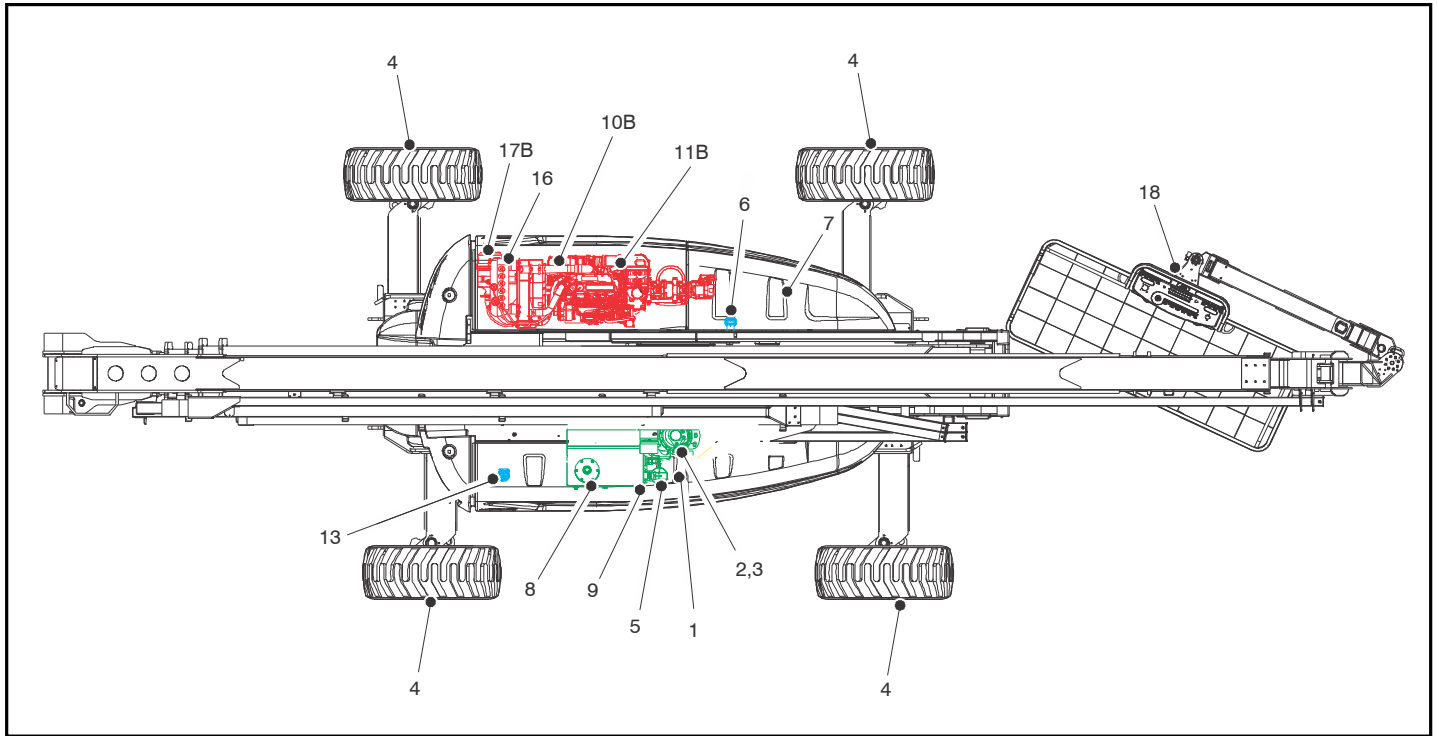

Figure 7-5. Operator Maintenance and Lubrication Diagram - Deutz 2011/CAT Engines



**Figure 7-6. Operator Maintenance and Lubrication Diagram - Deutz 2.9 Engine**

## SECTION 7 - GENERAL SPECIFICATIONS & OPERATOR MAINTENANCE

### 7.3 OPERATOR MAINTENANCE

**NOTE:** The following numbers correspond to those in Figure 7-5., Operator Maintenance and Lubrication Diagram - Deutz 2011/CAT Engines.

**Table 7-16. Lubrication Specifications**

KEY	SPECIFICATIONS
MPG	Multipurpose Grease having a minimum dripping point of 350° F (177° C). Excellent water resistance and adhesive qualities, and being of extreme pressure type. (Timken OK 40 pounds minimum.)
EPGL	Extreme Pressure Gear Lube (oil) meeting API service classification GL-5 or MIL-Spec MIL-L-2105
HO	Hydraulic Oil. API service classification GL-3, e.g. Mobilfluid 424.
EO	Engine (crankcase) Oil. Gas - API SF, SH, SG class, MIL-L-2104. Diesel - API CC/CD class, MIL-L-2104B/MIL-L-2104C.

#### **NOTICE**

**LUBRICATION INTERVALS ARE BASED ON MACHINE OPERATION UNDER NORMAL CONDITIONS. FOR MACHINES USED IN MULTI-SHIFT OPERATIONS AND/OR EXPOSED TO HOSTILE ENVIRONMENTS OR CONDITIONS, LUBRICATION FREQUENCIES MUST BE INCREASED ACCORDINGLY.**

**NOTE:** It is recommended as a good practice to replace all filters at the same time.

#### 1. Swing Bearing - Remote Lube

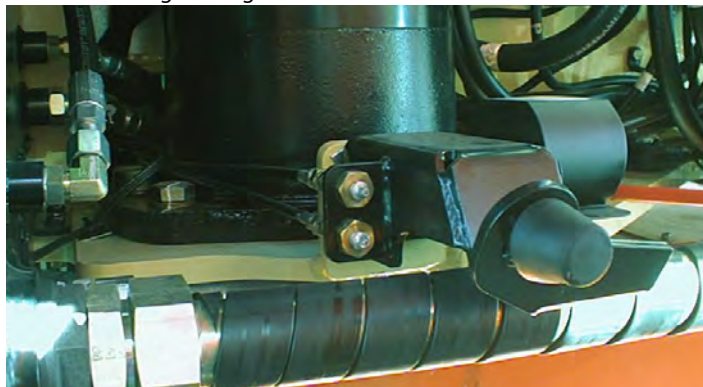

Lube Point(s) - 2 Grease Fitting  
Capacity - A/R  
Lube - MPG  
Interval - Every 3 months or 150 hours of operation



## SECTION 7 - GENERAL SPECIFICATIONS & OPERATOR MAINTENANCE

### 2. Swing Gearbox

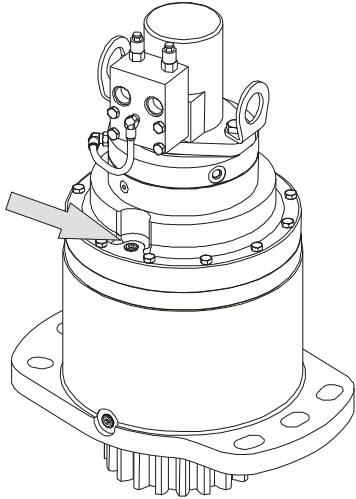

Lube Point(s) - Fill Plug  
Capacity - 79 ounces (2.3 L)  
Lube - GL-5  
Interval - Check level every 150 hrs/Change every 1200 hours of operation. Fill to cover ring gear.

### 3. Swing Brake

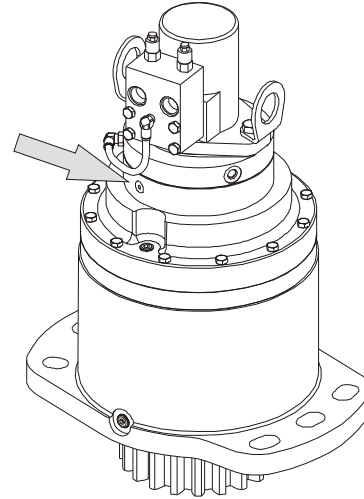

Lube Point(s) - Fill Plug  
Capacity - 2.7 ounces (80 ml)  
Lube - DTE24  
Interval - Check level every 150 hrs/Change every 1200 hours of operation.

## SECTION 7 - GENERAL SPECIFICATIONS & OPERATOR MAINTENANCE

### 4. A: Wheel Drive Hub - Bonfiglioli

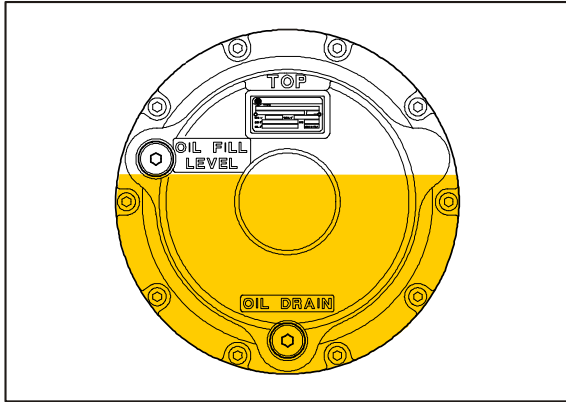

Lube Point(s) - Level/Fill Plug

Capacity - 2.1 quarts (2 liters)  $\pm$  10%

Lube - EPGL

Interval - Change after first 150 hours then every 1200 hours of operation

Comments - Place Fill port at 12 o'clock position and Check port at 8 o'clock position. Pour lubricant into fill port until it just starts to flow out of check port.

### B: Wheel Drive Hub - Reggiana Riduttori



Lube Point(s) - Level/Fill Plug

Capacity - 0.5 quarts (0.5 liters)  $\pm$  10%

Lube - EPGL

Interval - Change after first 150 hours then every 1200 hours of operation

Comments - Place Fill port at 12 o'clock position and Check port at 3 o'clock position. Pour lubricant into fill port until it just starts to flow out of check port.

**5. Hydraulic Return Filter**

Lube Point(s) - Replaceable Element

Interval - Change after first 50 hours and every 300 hours thereafter or as indicated by condition indicator.



**Figure 7-7. Hydraulic Return Filter Condition Indicator**

## SECTION 7 - GENERAL SPECIFICATIONS & OPERATOR MAINTENANCE

### 6. Hydraulic Charge Filter



or



Lube Point(s) - Replaceable Element

Interval - Change after first 50 hours and every 300 hours thereafter or as indicated by condition indicator (if equipped)

## SECTION 7 - GENERAL SPECIFICATIONS & OPERATOR MAINTENANCE

### 7. Main Valve Filter



Lube Point(s) - Replaceable Element

Interval - Change after first 50 hours and every 300 hours thereafter

### 8. Hydraulic Oil

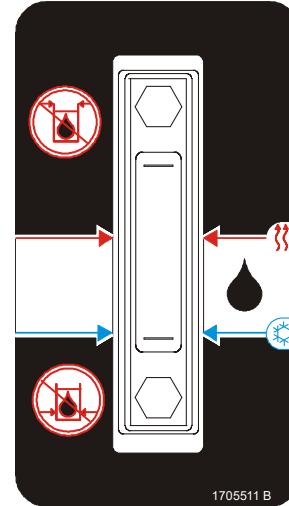

FULL LEVEL (HOT OIL)

FULL LEVEL (COLD OIL)

Lube Point(s) - Fill Cap

Capacity - 55 gallons (208 liters) Tank

Lube - HO

Interval - Check level daily. Change every 2 years or 1200 hours of operation.

## SECTION 7 - GENERAL SPECIFICATIONS & OPERATOR MAINTENANCE

### 9. Suction Strainers (In Tank)

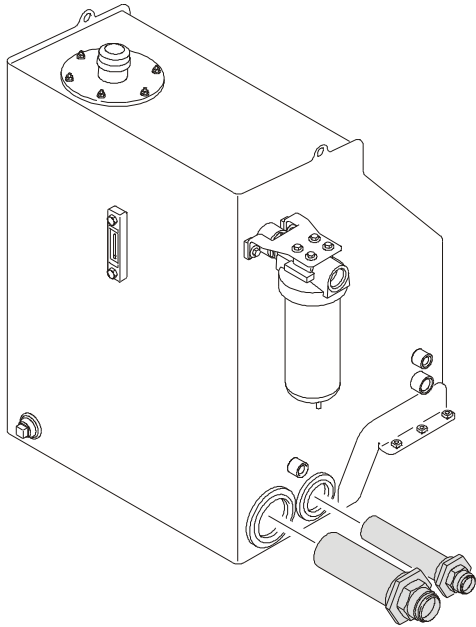

Lube Point(s) - 2

Interval - Every 2 years or 1200 hours of operation.

Remove and clean at time of hydraulic oil change.

### 10. A. Oil Change w/Filter - Deutz 2011



Lube Point(s) - Fill Cap/Spin-on Element

Capacity - 11 Quarts (10.5 L) w/Filter

Lube - EO

Interval - Check level daily; change every 500 hours or six months, whichever comes first. Adjust final oil level by mark on dipstick.

**B. Oil Change w/Filter - Deutz TCD2.9**



Lube Point(s) - Fill Cap/Spin-on Element

Capacity - 2.4 Gallon (8.9 L)

Lube - EO

Interval - Check level daily; change every 500 hours or six months, whichever comes first. Adjust final oil level by mark on dipstick.

## SECTION 7 - GENERAL SPECIFICATIONS & OPERATOR MAINTENANCE

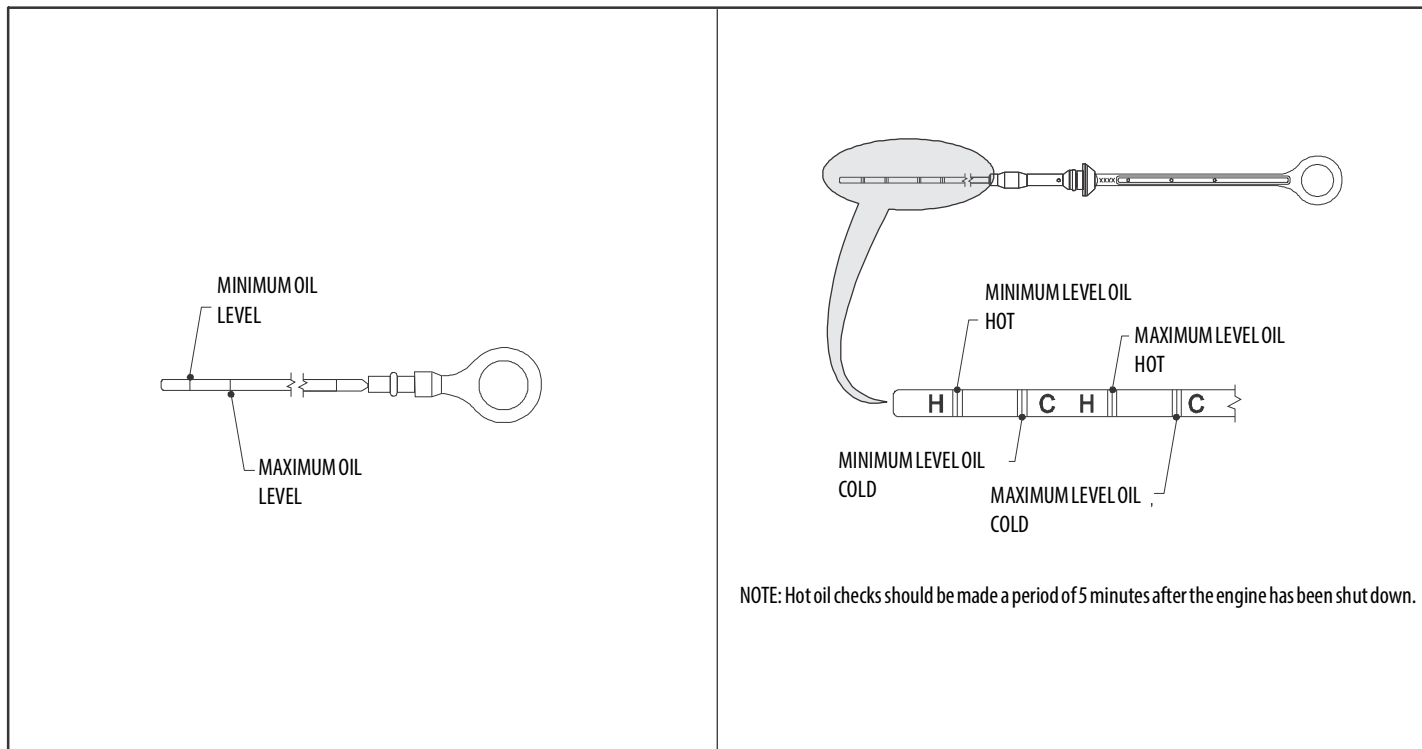

Figure 7-8. Deutz 2011 Engine Dipstick



## SECTION 7 - GENERAL SPECIFICATIONS & OPERATOR MAINTENANCE

### 11. A. Fuel Filter - Deutz 2011



Lube Point(s) - Replaceable Element  
Interval - Every year or 600 hours of operation

### B. Fuel Filter - Deutz TCD2.9



Lube Point(s) - Replaceable Element  
Interval - Every year or 500 hours of operation

## SECTION 7 - GENERAL SPECIFICATIONS & OPERATOR MAINTENANCE

### 12. Fuel Strainer - Deutz 2011

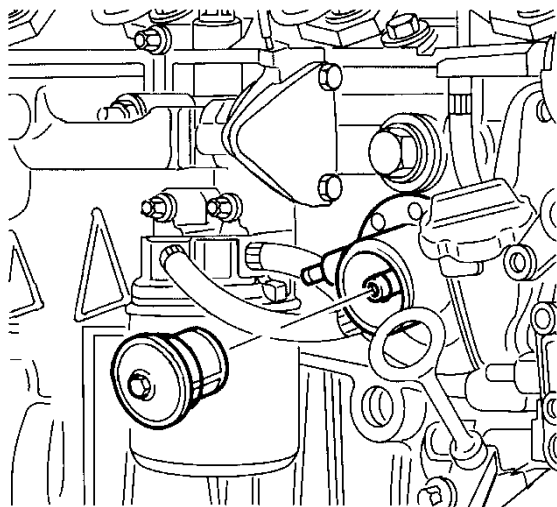

Lube Point(s) - Replaceable Element  
Interval - Every year or 600 hours of operation

### 13. Fuel Pre-Filter TCD2.9



Lube Point(s) - Replaceable Element  
Interval - Drain water daily; Change every year or 500 hours of operation

## SECTION 7 - GENERAL SPECIFICATIONS & OPERATOR MAINTENANCE

### 14. Oil Change w/Filter - CAT

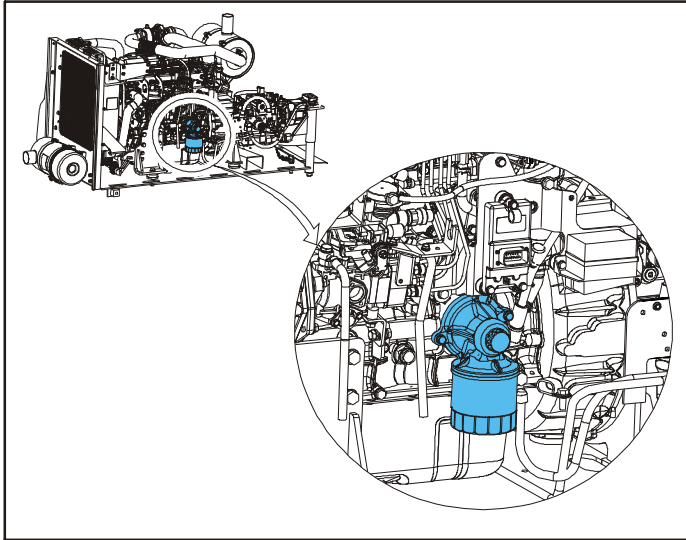

Lube Point(s) - Fill Cap/Spin-on Element (element can be accessed from below engine tray)

Capacity - 10.5 Quarts (10 L)

Lube - EO

Interval - Check level daily; change every 150 hours or three months, whichever comes first. Adjust final oil level by mark on dipstick.

### 15. Fuel Filter/Water Separator - CAT



Lube Point(s) - Replaceable Element

Interval - Drain water daily; Replace element every year or 600 hours of operation

## SECTION 7 - GENERAL SPECIFICATIONS & OPERATOR MAINTENANCE

### 16. Radiator Coolant TCD2.9



Lube Point(s) - Fill Cap  
Capacity - 3.2Gallon (12.1 L)  
Lube - Anti-Freeze  
Interval - Check level daily; change every 1000 hours or 2 years, whichever comes first.

### 17. A. Air Filter -Deutz 2011/CAT

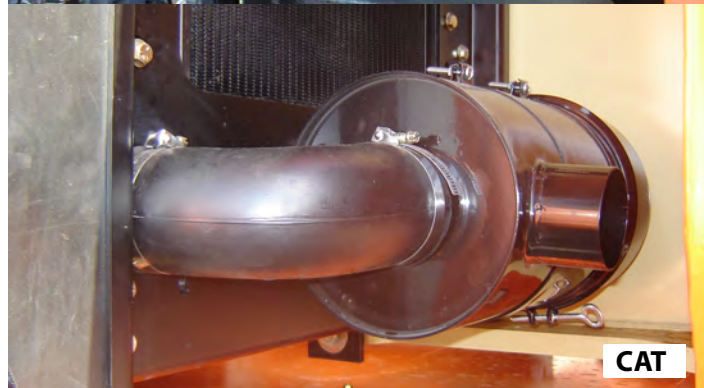
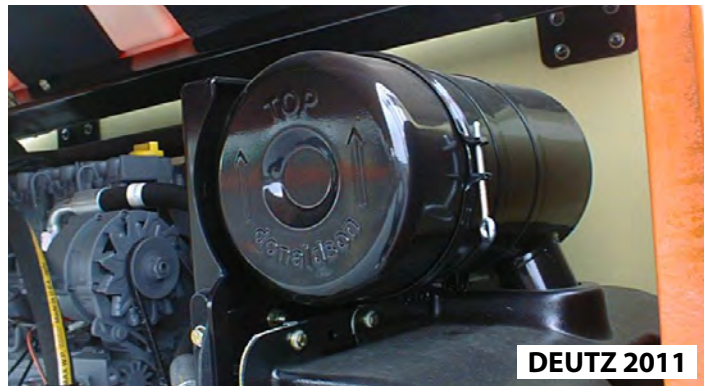

## SECTION 7 - GENERAL SPECIFICATIONS & OPERATOR MAINTENANCE

Lube Point(s) - Replaceable Element

Interval - Every 6 months or 300 hours of operation or as indicated by the condition indicator

B. Air Filter - Deutz TCD2.9



Lube Point(s) - Replaceable Element

Interval - Every 6 months or 300 hours of operation or as indicated by the condition indicator

Comments - Check Dust Valve daily

18. Platform Filter



Lube Point(s) - Replaceable Element

Interval - Change after first 50 hours and then every year or 600 hours of operation thereafter

### 19. Optional Fuel Filter/Water Separator

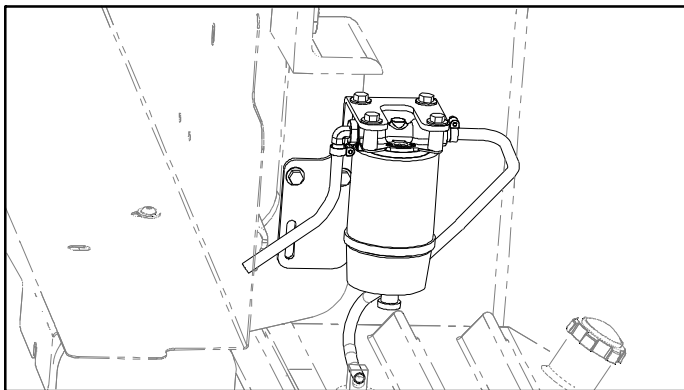

Lube Point(s) - Replaceable Element

Interval - Drain water daily; Change every year or 600 hours of operation

## 7.4 TIRES & WHEELS

### Tire Damage

For polyurethane foam filled tires, JLG Industries, Inc. recommends that when any of the following are discovered, measures must be taken to remove the JLG product from service immediately and arrangements must be made for replacement of the tire or tire assembly.

- a smooth, even cut through the cord plies which exceeds 3 inches (7.5 cm) in total length
- any tears or rips (ragged edges) in the cord plies which exceeds 1 inch (2.5 cm) in any direction
- any punctures which exceed 1 inch in diameter
- any damage to the bead area cords of the tire

If a tire is damaged but is within the above noted criteria, the tire must be inspected on a daily basis to insure the damage has not propagated beyond the allowable criteria.

### Tire Replacement

JLG recommends a replacement tire be the same size, ply and brand as originally installed on the machine. Please refer to the JLG Parts Manual for the part number of the approved tires for a particular machine model. If not using a JLG approved replacement tire, we recommend that replacement tires have the following characteristics:

- Equal or greater ply/load rating and size of original
- Tire tread contact width equal or greater than original
- Wheel diameter, width, and offset dimensions equal to the original
- Approved for the application by the tire manufacturer (including inflation pressure and maximum tire load)

Unless specifically approved by JLG Industries Inc. do not replace a foam filled or ballast filled tire assembly with a pneumatic tire. When selecting and installing a replacement tire, ensure that all tires are inflated to the pressure recommended by JLG. Due to size variations between tire brands, both tires on the same axle should be the same.

### Wheel and Tire Replacement

The rims installed on each product model have been designed for stability requirements which consist of track width, tire pressure, and load capacity. Size changes such as rim width, center piece location, larger or smaller diameter, etc., without written factory recommendations, may result in an unsafe condition regarding stability.

### Wheel Installation

It is extremely important to apply and maintain proper wheel mounting torque.

#### **WARNING**

**WHEEL NUTS MUST BE INSTALLED AND MAINTAINED AT THE PROPER TORQUE TO PREVENT LOOSE WHEELS, BROKEN STUDS, AND POSSIBLE DANGEROUS SEPARATION OF WHEEL FROM THE AXLE. BE SURE TO USE ONLY THE NUTS MATCHED TO THE CONE ANGLE OF THE WHEEL.**

Tighten the lug nuts to the proper torque to prevent wheels from coming loose. Use a torque wrench to tighten the fasteners. If you do not have a torque wrench, tighten the fasteners with a lug wrench, then immediately have a service garage or dealer tighten the lug nuts to the proper torque. Over-tightening will result in breaking the studs or permanently deforming the mounting stud holes in the wheels. The proper procedure for attaching wheels is as follows:



## SECTION 7 - GENERAL SPECIFICATIONS & OPERATOR MAINTENANCE

1. Start all nuts by hand to prevent cross threading. DO NOT use a lubricant on threads or nuts.
2. Tighten nuts in the following sequence:
3. The tightening of the nuts should be done in stages. Following the recommended sequence, tighten nuts per wheel torque chart.

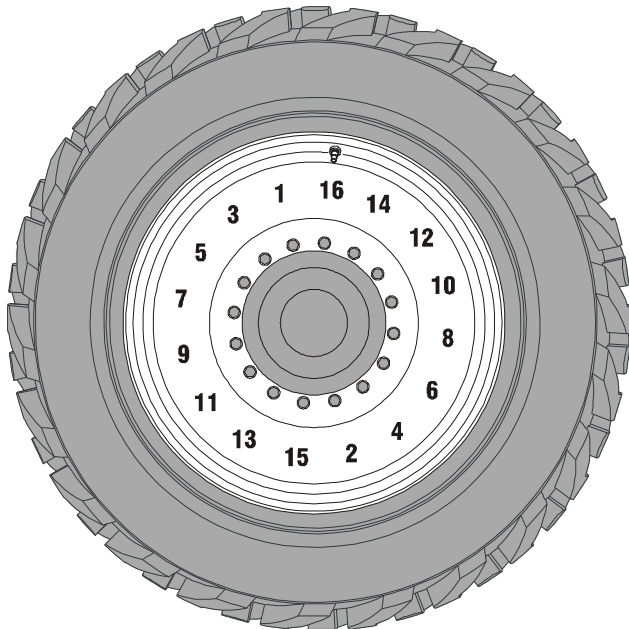

**Table 7-17. Wheel Torque Chart**

TORQUE SEQUENCE		
1st Stage	2nd Stage	3rd Stage
45ft. lbs. (60 Nm)	100 ft. lbs. (140 Nm)	180 ft. lbs. (252 Nm)

4. Wheel nuts should be torqued before first road use and after each wheel removal. Check and torque every 3 months or 150 hours of operation.



## **7.4 SUPPLEMENTAL INFORMATION ONLY APPLICABLE TO CE MACHINES**

The following information is provided in accordance with the requirements of the European Machinery Directive 2006/42/EC.

The A-Weighted emission sound pressure level at the work platform is less than 70 dB(A).

The guaranteed Sound Power Level (LWA) per European Directive 2000/14/EC (Noise Emission in the Environment by Equipment for Use Outdoors) based on test methods in accordance with Annex III, Part B, Method 1 and 0 of the directive, is 104 dB(A) for machines equipped with Stage IIIA engines and 110 dB(A) for machines equipped with Stage IIIB engines.

The vibration total value to which the hand-arm system is subjected does not exceed  $2,5 \text{ m/s}^2$ . The highest root mean square value of weighted acceleration to which the whole body is subjected does not exceed  $0,5 \text{ m/s}^2$ .

### EC Declaration of Conformity

**Manufacturer:**

JLG Industries, Inc.

**Address:**

1 JLG Drive  
1McConnellsburg, PA 17233 USA

**Technical File:**

JLG EMEA B.V.  
Polaris avenue 63,  
2132 JH Hoofddorp  
The Netherlands

**Contact / Position:**

Director of Engineering  
Europe

**Date / Place:**

Hoofddorp, Netherlands

**Machine Type:**

Mobile Elevating Work Platform

**Model Type:**

1250AJP

**Notified Body:**

Kuiper Certificering b.v.

**EC-Number:**

2842

**Address:**

Van Slingelandtstraat 75, 7331 NM  
Apeldoorn, The Netherlands

**Certificate Number:**

KCEC4426

**Reference Standards:**

- EN 55011:2009/A1:2010
- EN 61000-6-2:2005
- EN 60204-1:2018
- EN 280:2013+ A1:2015
- EN ISO 12100:2010

JLG Industries Inc. hereby declares that the above mentioned machine conforms with the requirements of:

- 2006/42/EC - Machinery Directive
- 2014/30/EU - EMC Directive
- 2014/53/EU - RED Directive (If fitted with optional equipment)
- 2000/14/EC - Outdoor Noise Directive

**NOTE:** *This declaration conforms with the requirements of annex II-A of the council directive 2006/42/EC. Any modification to the above described machine violates the validity of this declaration.*









An Oshkosh Corporation Company

***Corporate Office***

***JLG Industries, Inc.***

***1 JLG Drive***

***McConnellsburg, PA 17233-9533 USA***

***☎ (717) 485-5161 (Corporate)***

***☎ (877) 554-5438 (Customer Support)***

***☎ (717) 485-6417***

***Visit our website for JLG Worldwide Locations.***

***[www.jlg.com](http://www.jlg.com)***