



# *Operators and Safety Manual*

**Model  
120HX**

**3120685**  
April 20, 2000

**ANSI**

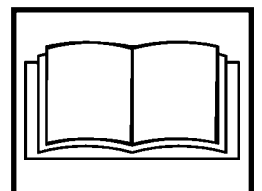

---

**CALIFORNIA PROPOSITION 65  
BATTERY WARNING**

**Battery posts,  
terminals and related  
accessories contain  
lead and lead compounds,  
chemicals known to the  
State of California  
to cause cancer and  
reproductive harm.**

**WASH HANDS  
AFTER HANDLING !**



**WARNING:**



**The engine exhaust from this product  
contains chemicals known to the State  
of California to cause cancer, birth  
defects, or other reproductive harm.**

1702961

## FOREWORD

The purpose of this manual is to provide users with the operating procedures essential for the promotion of proper machine operation for its intended purpose. It is important to over-stress proper machine usage. All information in this manual should be READ and UNDERSTOOD before any attempt is made to operate the machine. **YOUR OPERATING MANUAL IS YOUR MOST IMPORTANT TOOL** - Keep it with the machine. **REMEMBER ANY EQUIPMENT IS ONLY AS SAFE AS THE OPERATOR.**

**BECAUSE THE MANUFACTURER HAS NO DIRECT CONTROL OVER MACHINE APPLICATION AND OPERATION, PROPER SAFETY PRACTICES ARE THE RESPONSIBILITY OF THE USER AND HIS OPERATING PERSONNEL.**

**ALL INSTRUCTIONS IN THIS MANUAL ARE BASED ON THE USE OF THE MACHINE UNDER PROPER OPERATING CONDITIONS, WITH NO DEVIATIONS FROM THE ORIGINAL DESIGN. ALTERATION AND/OR MODIFICATION OF THE MACHINE IS STRICTLY FORBIDDEN, WITHOUT WRITTEN APPROVAL FROM JLG INDUSTRIES, PER OSHA REGULATIONS AND APPLICABLE ANSI STANDARDS.**



THIS SAFETY ALERT SYMBOL IS USED TO CALL ATTENTION TO POTENTIAL HAZARDS WHICH MAY LEAD TO SERIOUS INJURY OR DEATH IF IGNORED.

Safety of personnel and proper use of the machine are of primary concern, **DANGER, WARNING, CAUTION, IMPORTANT, INSTRUCTIONS** and **NOTE** are inserted throughout this manual to emphasize these areas. They are defined as follows:

### **DANGER**

DANGER INDICATES AN IMMINENTLY HAZARDOUS SITUATION WHICH, IF NOT AVOIDED WILL RESULT IN SERIOUS INJURY OR DEATH.]

### **WARNING**

WARNING INDICATES A POTENTIALLY HAZARDOUS SITUATION WHICH, IF NOT AVOIDED COULD RESULT IN SERIOUS INJURY OR DEATH.

### **CAUTION**

CAUTION INDICATES A POTENTIALLY HAZARDOUS SITUATION WHICH, IF NOT AVOIDED, MAY RESULT IN MINOR OR MODERATE INJURY. IT MAY ALSO BE USED TO ALERT AGAINST UNSAFE PRACTICES

### **IMPORTANT**

IMPORTANT OR INSTRUCTIONS INDICATES A PROCEDURES ESSENTIAL FOR SAFE OPERATION AND WHICH, IF NOT FOLLOWED, MAY RESULT IN A MALFUNCTION OR DAMAGE TO THE MACHINE.

### **IMPORTANT**

JLG INDUSTRIES MAY HAVE ISSUED SAFETY RELATED BULLETINS FOR YOUR JLG PRODUCT. CONTACT JLG INDUSTRIES INC. OR THE LOCAL AUTHORIZED JLG DISTRIBUTOR FOR INFORMATION CONCERNING SAFETY RELATED BULLETINS WHICH MAY HAVE BEEN ISSUED FOR YOUR JLG PRODUCT. ALL ITEMS REQUIRED BY THE SAFETY RELATED BULLETINS MUST BE COMPLETED ON THE AFFECTED JLG PRODUCT

Due to continuous product improvements, JLG Industries, Inc. reserves the right to make specification changes without prior notification. Contact JLG Industries, Inc. for updated information.

**This page left blank intentionally.**

All procedures herein are based on the use of the machine under proper operating conditions, with no deviations from original design intent... as per OSHA regulations and applicable ANSI standards.

## READ & HEED!

The ownership, use, service, and/or maintenance of this machine is subject to various governmental and local laws and regulations. It is the responsibility of the owner/user to be knowledgeable of these laws and regulations and to comply with them. Owner/user/operator/lessor and lessee must be familiar with Sections 6,7,8,9, and 10 of ANSI A92.5-1992. These sections contain the responsibilities of the owner, users, operators, lessors, and lessees concerning safety, training, inspection, maintenance, application and operation. The most prevalent regulations of this type in the United States are the Federal OSHA Safety Regulations\*. Listed below, in abbreviated form are some of the requirements of Federal OSHA regulations in effect as of the date of publication of this handbook.

The listing of these requirements shall not relieve the owner/user of the responsibility and obligation to determine all applicable laws and regulations and their exact wording and requirements, and to comply with the requirements. Nor shall the listing of these requirements constitute an assumption of responsibility of liability on the part of JLG Industries, Inc.

1. Only trained and authorized operators shall be permitted to operate the aerial lift.
2. A malfunctioning lift shall be shut down until repaired.
3. The controls shall be plainly marked as to their function.
4. The controls shall be tested each day prior to use to determine that they are in safe operating condition.

5. All personnel in the platform shall, at all times, wear approved fall protection devices and other safety gear as required.
6. Load limits specified by the manufacturer shall not be exceeded.
7. Instruction and warning placards must be legible.
8. Aerial lifts may be field modified for uses other than those intended by the manufacturer only if certified in writing by the manufacturer to be in conformity to JLG requirements and to be at least as safe as it was prior to modification.
9. Aerial lifts shall not be used near electric power lines unless the lines have been de energized or adequate clearance is maintained (See OSHA 29 CFR 1910.67 and 1926.453).
10. Employees using aerial lifts shall be instructed on how to recognize and avoid unsafe conditions and hazards.
11. Ground controls shall not be operated unless permission has been obtained from personnel in the platform, except in case of an emergency.
12. Regular inspection of the job site and aerial lift shall be performed by competent persons.
13. Personnel shall always stand on the floor of the platform, not on boxes, planks, railing or other devices, for a work position.

\*Applicable Federal OSHA regulations for the United States, as of the date of publication of this manual, include, but are not limited to, 29 CFR 1910.67, 29 CFR 1926.20, 29 CFR 1926.21, 29 CFR 1926.28, and 29 CFR 1926.453.

## **REVISION LOG**

June 1992	-	Original Issue
September, 1997	-	Revised
November, 1997	-	Revised
March 1, 1999	-	Revised
April 11, 2000	-	Revised
Prop65 page added	-	Updated 4-20-00
4-1	-	Updated 4-20-00

**TABLE OF CONTENTS**

<b>SUBJECT - SECTION, PARAGRAPH</b>	<b>PAGE NO.</b>
<b>SECTION - FOREWORD</b>	
<b>SECTION 1 - SAFETY PRECAUTIONS</b>	
1.1 General . . . . .	1-1
1.2 Driving/Towing. . . . .	1-1
1.3 Electrocution Hazard. . . . .	1-2
1.4 Pre-Operational . . . . .	1-2
1.5 Driving . . . . .	1-4
1.6 Operation. . . . .	1-5
1.7 Towing and Hauling . . . . .	1-8
<b>SECTION 2 - PREPARATION AND INSPECTION</b>	
2.1 General . . . . .	2-1
2.2 Preparation For Use . . . . .	2-1
2.3 Delivery and Frequent Inspection . . . . .	2-1
2.4 Daily Walk-Around Inspection . . . . .	2-4
2.5 Daily Functional Check . . . . .	2-9
2.6 Torque Requirements . . . . .	2-12
2.7 Battery Maintenance . . . . .	2-13
<b>SECTION 3 - USER RESPONSIBILITIES AND MACHINE CONTROL</b>	
3.1 General . . . . .	3-1
3.2 Personnel Training . . . . .	3-1
3.3 Operating Characteristics and Limitations . . . . .	3-2
3.4 Controls and Indicators. . . . .	3-5
3.5 Placards and Decals . . . . .	3-15
<b>SECTION 4 - MACHINE OPERATION</b>	
4.1 Description . . . . .	4-1
4.2 General . . . . .	4-1
4.3 Engine Operation . . . . .	4-2
4.4 Traveling (Driving/Steering) . . . . .	4-2
4.5 Axles . . . . .	4-3
4.6 Parking and Stowing . . . . .	4-5
4.7 Platform . . . . .	4-5
4.8 Boom . . . . .	4-6
4.9 Shut Down and Park . . . . .	4-6
4.10 Tie Down and Lifting . . . . .	4-7
4.11 Swing-Away Jib . . . . .	4-12
<b>SECTION 5 - OPTIONAL EQUIPMENT</b>	
5.1 Cold Start Kit (Diesel Engine) . . . . .	5-1
5.2 Travel/motion Alarm . . . . .	5-1
5.3 Tilt Alarm . . . . .	5-1
5.4 Rotating Beacon . . . . .	5-1
5.5 Hostile Environment Package . . . . .	5-1
5.6 110 Volt Generator . . . . .	5-1
<b>SECTION 6 - EMERGENCY PROCEDURES</b>	
6.1 General . . . . .	6-1
6.2 Emergency Towing Procedures . . . . .	6-1

**TABLE OF CONTENTS (Continued)**

---

**TABLE OF CONTENTS (continued)**

<b>SUBJECT - SECTION, PARAGRAPH</b>	<b>PAGE NO.</b>
6.3 Emergency Controls and Their Locations . . . . .	6-1
6.4 Emergency Operation . . . . .	6-2
6.5 Incident Notification . . . . .	6-3
<b>SECTION 7 - INSPECTION AND REPAIR LOG</b>	

**LIST OF FIGURES**

<b>FIGURE NO.</b>	<b>TITLE</b>	<b>PAGE NO.</b>
2-1.	Machine Nomenclature . . . . .	2-3
2-2.	Daily Walk-Around Inspection . . . . .	2-6
2-3.	Lubrication Chart . . . . .	2-10
2-4.	Torque Chart . . . . .	2-14
3-1.	Position of Least Forward Stability . . . . .	3-3
3-2.	Position of Least Backward Stability . . . . .	3-4
3-3.	Ground Control Station - Prior to May 1994 . . . . .	3-6
3-4.	Ground Control Station - May 1994 to Present . . . . .	3-7
3-5.	Axle Extension/Axle Jacks Control . . . . .	3-9
3-6.	Remote Control Box . . . . .	3-10
3-7.	Platform Station - Prior to May 1994 . . . . .	3-12
3-8.	Platform Station - May 1994 to Present . . . . .	3-13
3-9.	Caution Decal Location - Sheet 1 . . . . .	3-16
3-10.	Caution Decal Location - Sheet 2 . . . . .	3-17
3-11.	Control Panel Symbols - Sheet 1 of 2 . . . . .	3-20
3-12.	Control Panel Symbols - Sheet 2 of 2 . . . . .	3-21
4-1.	Spindle Stop Pin Usage . . . . .	4-4
4-2.	Grade and Side Slope . . . . .	4-6
4-3.	Machine Tie Down - Sheet 1 . . . . .	4-8
4-4.	Machine Tie Down - Sheet 2 . . . . .	4-9
4-5.	Machine Tie Down - Sheet 3 . . . . .	4-10
4-6.	Machine Tie Down - Sheet 4 . . . . .	4-11
4-7.	Lifting Chart . . . . .	4-12
4-8.	Swing-Away Jib . . . . .	4-13
6-1.	Disconnecting the Drive Hubs . . . . .	6-1

**LIST OF TABLES**

<b>TABLE NO.</b>	<b>TITLE</b>	<b>PAGE NO.</b>
1-1	Minimum Safe Approach Distances (M.S.A.D.) to energized (exposed or insulated) power lines and parts . . . . .	1-2
7-1	Inspection and Repair Log . . . . .	7-1



## SECTION 1. SAFETY PRECAUTIONS

### 1.1 GENERAL

This section prescribes the proper and safe practices for major areas of machine usage. In order to promote proper usage of the machine, it is mandatory that a daily routine be established based on instructions given in this section. A maintenance program must be also be established by a qualified person and must be followed to ensure that the machine is safe to operate.

The owner/user/operator of the machine should not accept operating responsibility until this manual has been read and understood, and operation of the machine, under the supervision of an experienced and qualified person, has been completed. Owner/user/operator must be familiar with Sections 6, 7, 8, 9, and 10 of ANSI A92.5-1992. These sections contain the responsibilities of the owner, users, operators, lessors and lessees concerning safety, training, inspection, maintenance, application and operation. If there is a question on application and or operation, JLG Industries Inc., should be consulted.

#### **⚠ WARNING**

MODIFICATION OR ALTERATION OF AN AERIAL PLATFORM SHALL BE MADE ONLY WITH PRIOR WRITTEN PERMISSION OF THE MANUFACTURER.

### 1.2 DRIVING/TOWING

Before driving the machine, the user must be familiar with the drive, steer and stopping characteristics. This is especially important when driving in close quarters.

The user should be familiar with the driving surface before driving. The surface should be firm and level and grades should not exceed the allowable grade for the machine.

**NOTE:** Remember that the key to safe and proper usage is common sense and its careful application.

The machine is not equipped with provisions for towing. Refer to Section 6 for emergency towing procedures.

#### **SPECIAL NOTE:**

#### **⚠ WARNING**

FAILURE TO COMPLY WITH SAFETY PRECAUTIONS LISTED IN THIS SECTION AND ON THE MACHINE COULD RESULT IN MACHINE DAMAGE, PERSONNEL INJURY OR DEATH, AND IS A SAFETY VIOLATION.

## SECTION 1 - SAFETY PRECAUTIONS

Table 1-1. Minimum Safe Approach Distances (M.S.A.D.) to energized (exposed or insulated) power lines and parts

Voltage Range (Phase to Phase)	MINIMUM SAFE APPROACH DISTANCE in Feet (Meters)
0 to 300V	AVOID CONTACT
Over 300V to 50 KV	10 (3)
Over 50KV to 200 KV	15 (5)
Over 200 KV to 350 KV	20 (6)
Over 350 KV to 500 KV	25 (8)
Over 500 KV to 750 KV	35 (11)
Over 750 KV to 1000 KV	45 (14)

**DANGER: DO NOT** maneuver machine or personnel inside **PROHIBITED ZONE**. **ASSUME** all electrical parts and wiring are **ENERGIZED** unless known otherwise.

### 1.3 ELECTROCUTION HAZARD

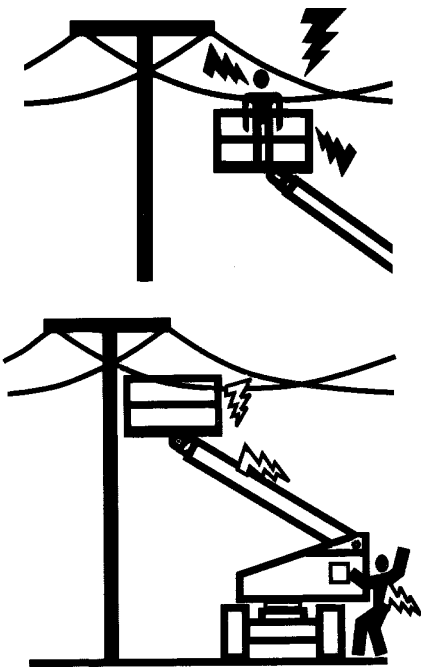

- MAINTAIN SAFE CLEARANCE FROM ELECTRICAL LINES AND APPARATUS. ALLOW FOR BOOM SWAY, ROCK OR SAG AND ELECTRICAL LINE SWAYING. THE MACHINE DOES NOT PROVIDE PROTECTION

FROM CONTACT WITH OR PROXIMITY TO AN ELECTRICALLY CHARGED CONDUCTOR.

- MAINTAIN A CLEARANCE OF AT LEAST 10 FEET (3 M) BETWEEN ANY PART OF THE MACHINE OR ITS LOAD AND ANY ELECTRICAL LINE OR APPARATUS CARRYING UP TO 50,000 VOLTS. ONE FOOT ADDITIONAL CLEARANCE IS REQUIRED FOR EVERY ADDITIONAL 30,000 VOLTS OR LESS.

### 1.4 PRE-OPERATIONAL

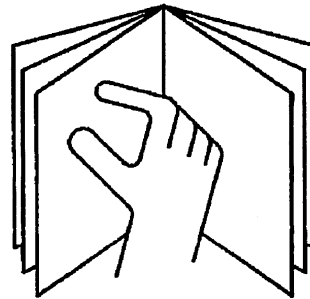

- READ YOUR MANUAL. UNDERSTAND WHAT YOU'VE READ - THEN BEGIN OPERATIONS.
- ALLOW ONLY AUTHORIZED AND QUALIFIED PERSONNEL TO OPERATE MACHINE WHO HAVE DEMONSTRATED THAT THEY UNDERSTAND SAFE AND PROPER OPERATION AND MAINTENANCE OF THE UNIT.

## SECTION 1 - SAFETY PRECAUTIONS

- AN OPERATOR MUST NOT ACCEPT OPERATING RESPONSIBILITIES UNTIL ADEQUATE TRAINING HAS BEEN GIVEN BY COMPETENT AND AUTHORIZED PERSONS.
- BEFORE OPERATION, CHECK WORK AREA FOR OVERHEAD ELECTRIC LINES, MACHINE TRAFFIC SUCH AS BRIDGE CRANES, HIGHWAY, RAILWAY AND CONSTRUCTION EQUIPMENT.

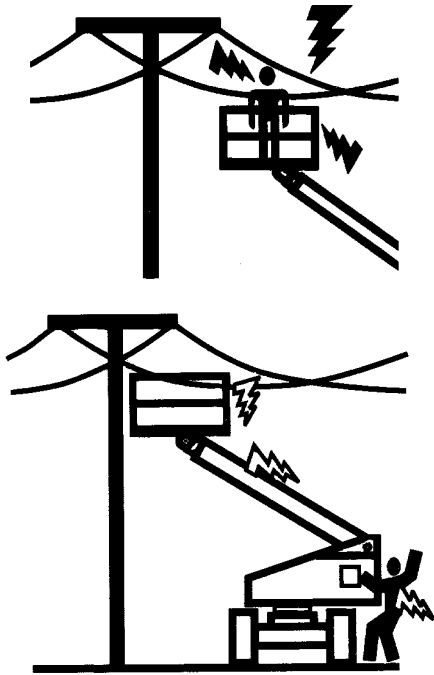

- PRECAUTIONS TO AVOID ALL KNOWN HAZARDS IN THE WORK AREA MUST BE TAKEN BY THE OPERATOR AND HIS SUPERVISOR BEFORE STARTING THE WORK.
- DO NOT OPERATE THIS MACHINE UNLESS IT HAS BEEN SERVICED AND MAINTAINED ACCORDING TO THE MANUFACTURERS SPECIFICATIONS AND SCHEDULE.
- ENSURE DAILY INSPECTION AND FUNCTION CHECK IS PERFORMED PRIOR TO PLACING MACHINE INTO OPERATION.

- NEVER DISABLE OR MODIFY THE FOOTSWITCH OR ANY OTHER SAFETY DEVICE. ANY UNAUTHORIZED MODIFICATION OF THE MACHINE IS A SAFETY VIOLATION AND IS A VIOLATION OF OSHA REGULATIONS AND ANSI STANDARDS.

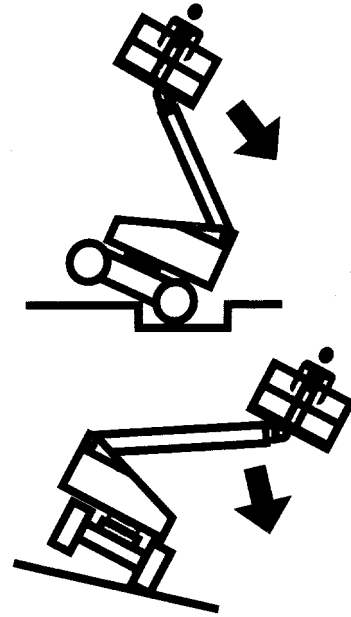

- DO NOT OPERATE MACHINE WHEN WIND CONDITIONS EXCEED 30 MPH (48 KMH).
- NEVER OPERATE BOOM FUNCTIONS (TELE, SWING, LIFT) WHEN MACHINE IS ON A TRUCK, OTHER VEHICLE, OR ABOVE GROUND STRUCTURE.
- THIS MACHINE CAN BE OPERATED IN NOMINAL AMBIENT TEMPERATURES OF 0° F TO 104° F (-20°C TO 40°C). CONSULT FACTORY TO OPTIMIZE OPERATION OUTSIDE THIS RANGE.

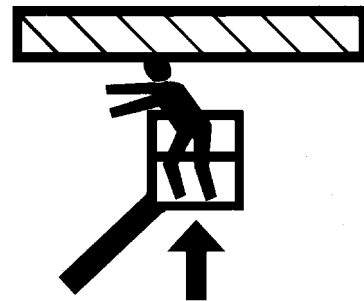

- APPROVED HEAD GEAR MUST BE WORN BY ALL OPERATING AND GROUND PERSONNEL.

## SECTION 1 - SAFETY PRECAUTIONS

---

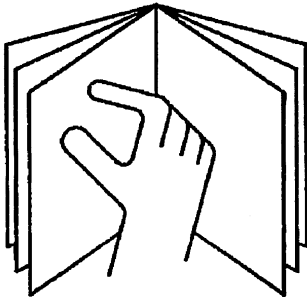

- READ AND OBEY ALL DANGERS, WARNINGS, CAUTIONS AND OPERATING INSTRUCTIONS ON MACHINE AND IN THIS MANUAL.
- BE FAMILIAR WITH LOCATION AND OPERATION OF GROUND STATION CONTROLS.

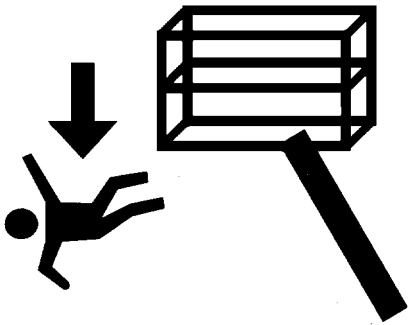

- ALWAYS USE THREE POINT CONTACT WHEN ENTERING OR EXITING THE MACHINE. FACE THE MACHINE WHEN YOU ENTER OR LEAVE. THREE POINT CONTACT MEANS THAT TWO HANDS AND ONE FOOT OR ONE HAND AND TWO FEET ARE IN CONTACT WITH THE MACHINE AT ALL TIMES DURING MOUNT AND DISMOUNT.

---

### 1.5 DRIVING

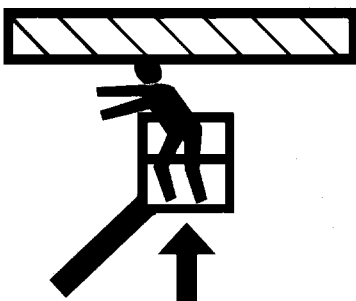

- WATCH FOR OBSTRUCTIONS AROUND MACHINE AND OVERHEAD WHEN DRIVING.

- ALWAYS POSITION BOOM OVER REAR (DRIVE) AXLE IN LINE WITH DIRECTION OF TRAVEL. REMEMBER, IF BOOM IS OVER FRONT (STEER) AXLE, DIRECTION OF STEER AND DRIVE MOVEMENT WILL BE OPPOSITE FROM NORMAL OPERATION.

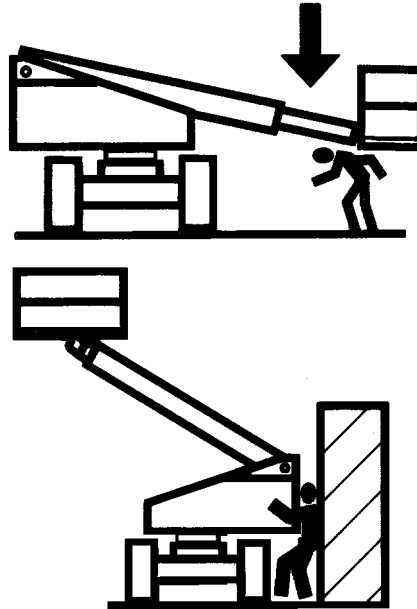

- DO NOT USE DRIVE FUNCTION TO POSITION PLATFORM CLOSE TO OBSTACLES. USE BOOM FUNCTION INSTEAD.
- WHEN DRIVING IN HIGH SPEED, SWITCH TO LOW SPEED BEFORE STOPPING. TRAVEL GRADES IN LOW DRIVE, HIGH ENGINE ONLY.
- DO NOT USE HIGH SPEED DRIVE WHEN IN RESTRICTED OR CLOSE QUARTERS, OR WHEN DRIVING IN REVERSE.
- BE AWARE OF STOPPING DISTANCES WHEN TRAVELING IN HIGH AND LOW SPEEDS.
- ALWAYS POST A LOOKOUT AND SOUND HORN WHEN DRIVING IN AREAS WHERE VISION IS OBSTRUCTED.
- KEEP NON-OPERATING PERSONNEL AT LEAST 6 FEET (2 M) AWAY FROM MACHINE DURING DRIVING OPERATIONS.

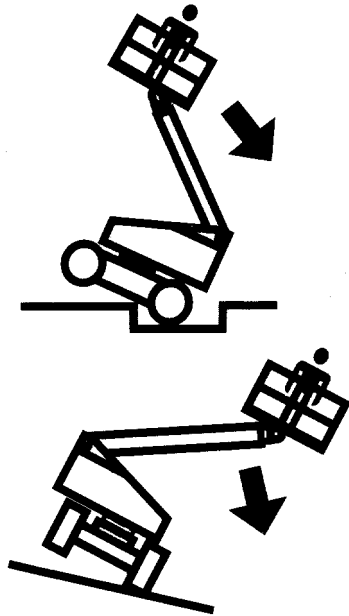

- CHECK TRAVEL PATH FOR PERSONS, HOLES, BUMPS, DROP-OFFS, OBSTRUCTIONS, DEBRIS, AND COVERINGS WHICH MAY CONCEAL HOLES AND OTHER HAZARDS.
- TRAVEL IS PERMITTED ON GRADES AND SIDESLOPES NO GREATER THAN THOSE INDICATED IN WARNING PLACARD AT MACHINE PLATFORM.
- OPERATION WITH BOOM RAISED IS RESTRICTED TO FIRM, LEVEL AND UNIFORM SURFACE.
- DO NOT TRAVEL ON SOFT OR UNEVEN SURFACES, AS TIPPING WILL OCCUR.
- ENSURE THAT GROUND CONDITIONS ARE ADEQUATE TO SUPPORT THE MAXIMUM TIRE LOAD.
- DO NOT DRIVE MACHINE NEAR PITS, LOADING DOCKS OR OTHER DROP-OFFS.

1.6 OPERATION.

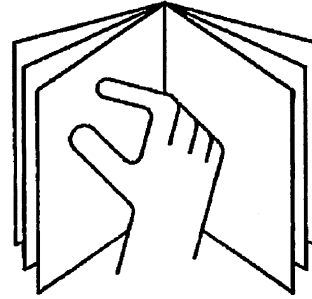

- READ YOUR MANUAL. UNDERSTAND WHAT YOU'VE READ - THEN BEGIN OPERATIONS.

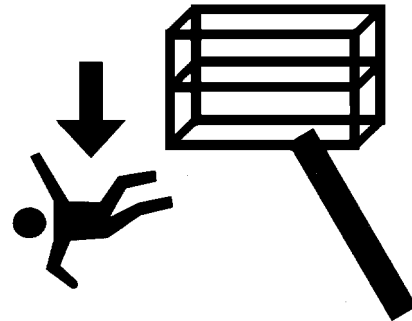

- PRIOR TO ENTERING AND EXITING PLATFORM AT GROUND LEVEL, FULLY LOWER THE BOOM. EXTEND BOOM UNTIL END OF FLY BOOM CONTACTS GROUND. WITH BOOM LIFT IN THIS CONFIGURATION, ENTER AND/OR EXIT PLATFORM THROUGH GATE OPENING.
- OSHA REQUIRES ALL PERSONS IN THE PLATFORM TO WEAR LANYARDS WITH AN APPROVED FALL PROTECTION DEVICE. SECURE LANYARD TO DESIGNATED LANYARD ATTACH POINT ON PLATFORM. KEEP GATE CLOSED AT ALL TIMES.
- TO AVOID FALLING - USE EXTREME CAUTION WHEN ENTERING OR LEAVING PLATFORM ABOVE GROUND. ENTER OR EXIT THRU GATE ONLY. PLATFORM FLOOR MUST BE WITHIN 1 FOOT (30 CM) OF ADJACENT - SAFE AND SECURE - STRUCTURE. ALLOW FOR PLATFORM VERTICAL MOVEMENT AS WEIGHT IS TRANSFERRED TO OR FROM PLATFORM.

## SECTION 1 - SAFETY PRECAUTIONS

---

- TRANSFERS BETWEEN A STRUCTURE AND THE AERIAL PLATFORM EXPOSE OPERATORS TO FALL HAZARDS. THIS PRACTICE SHOULD BE DISCOURAGED WHEREVER POSSIBLE. WHERE TRANSFER MUST BE ACCOMPLISHED TO PERFORM THE JOB TWO LANYARDS WITH AN APPROVED FALL PROTECTION DEVICE WILL BE USED. ONE LANYARD SHOULD BE ATTACHED TO THE AERIAL PLATFORM. THE OTHER TO THE STRUCTURE. THE LANYARD THAT IS ATTACHED TO THE AERIAL PLATFORM SHOULD NOT BE DISCONNECTED UNTIL SUCH TIME AS THE TRANSFER TO THE STRUCTURE IS COMPLETE. OTHERWISE, DO NOT STEP OUTSIDE OF PLATFORM.
- DO NOT ADD NOTICE BOARDS OR SIMILAR ITEMS TO THE PLATFORM. ADDITION OF SUCH ITEMS INCREASES THE EXPOSED WIND AREA OF THE MACHINE.
- NEVER POSITION LADDERS, STEPS, OR SIMILAR ITEMS ON UNIT TO PROVIDE ADDITIONAL REACH FOR ANY PURPOSE.
- WHEN RIDING IN OR WORKING FROM PLATFORM, BOTH FEET MUST BE FIRMLY POSITIONED ON THE FLOOR.
- KEEP OIL, MUD AND SLIPPERY SUBSTANCES CLEANED FROM FOOTWEAR AND PLATFORM FLOOR.
- NEVER "WALK" THE BOOM TO GAIN ACCESS TO OR LEAVE PLATFORM.
- NEVER PLACE HANDS OR ARMS IN TOWER BOOM OR UPRIGHT MECHANISM.
- KEEP ALL NON-OPERATING PERSONNEL AT LEAST 6 FEET (2 M) AWAY FROM THE MACHINE AT ALL TIMES.

- IF PLATFORM OR BOOM IS CAUGHT SO THAT ONE OR MORE WHEELS ARE OFF THE FLOOR, ALL PERSONNEL MUST BE REMOVED FROM PLATFORM BEFORE ATTEMPTING TO FREE MACHINE. USE CRANES, FORKLIFT TRUCKS OR OTHER EQUIPMENT TO REMOVE PERSONNEL AND STABILIZE MACHINE MOTION, IF NECESSARY.

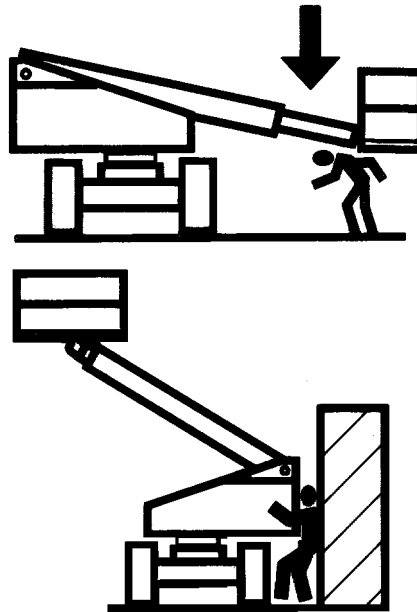

- THE OPERATOR IS RESPONSIBLE TO AVOID OPERATING MACHINE OVER GROUND PERSONNEL AND TO WARN THEM NOT TO WORK, WALK OR STAND UNDER A RAISED BOOM OR PLATFORM. POSITION BARRICADES ON FLOOR IF NECESSARY.

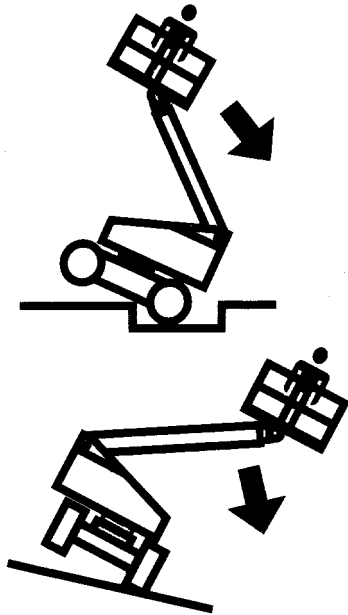

- ENSURE MACHINE IS POSITIONED ON A FIRM, LEVEL AND UNIFORM SUPPORTING SURFACE BEFORE RAISING OR EXTENDING BOOM.

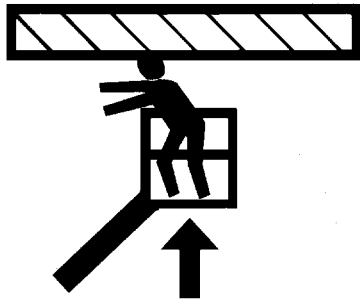

- CHECK CLEARANCES ABOVE, ON SIDES AND BOTTOM OF PLATFORM WHEN RAISING, LOWERING, SWINGING, AND TELESCOPING BOOM.
- EXERCISE EXTREME CAUTION AT ALL TIMES TO PREVENT OBSTACLES FROM STRIKING OR INTER-

FERING WITH OPERATING CONTROLS AND PERSONS IN PLATFORM.

- ENSURE THAT OPERATORS OF OTHER OVERHEAD AND FLOOR MACHINES ARE AWARE OF THE AERIAL PLATFORMS PRESENCE. DISCONNECT POWER TO OVERHEAD CRANES. POSITION BARRICADES ON FLOOR IF NECESSARY.
- NEVER "SLAM" A CONTROL SWITCH OR LEVER THROUGH NEUTRAL TO THE OPPOSITE DIRECTION. ALWAYS RETURN SWITCH TO NEUTRAL AND STOP; THEN MOVE SWITCH TO THE DESIRED POSITION. OPERATE LEVERS WITH SLOW, EVEN PRESSURE.
- DO NOT CARRY MATERIALS ON PLATFORM RAILING UNLESS APPROVED BY JLG INDUSTRIES INC.
- NEVER PUSH OR PULL THE MACHINE OR OTHER OBJECTS BY TELESCOPING THE BOOM.
- NEVER USE BOOM FOR ANY PURPOSE OTHER THAN POSITIONING PERSONNEL, THEIR TOOLS AND EQUIPMENT.
- NEVER EXCEED MANUFACTURERS RATED PLATFORM CAPACITY - REFER TO CAPACITY DECAL ON MACHINE. DISTRIBUTE LOADS EVENLY ON PLATFORM FLOOR.
- NEVER OPERATE A MALFUNCTIONING MACHINE. IF A MALFUNCTION OCCURS, SHUT DOWN THE MACHINE, RED TAG IT, AND NOTIFY PROPER AUTHORITIES.
- DO NOT REMOVE, MODIFY, OR DISABLE FOOT-SWITCH BY BLOCKING OR ANY OTHER MEANS.
- DO NOT ASSIST A STUCK OR DISABLED MACHINE BY PUSHING OR PULLING EXCEPT BY PULLING AT CHASSIS TIE-DOWN LUGS.
- NEVER ATTEMPT USING BOOM AS A CRANE. STRUCTURAL DAMAGE OR TIPPING MAY OCCUR.
- STOW BOOM AND SHUT OFF ALL POWER BEFORE LEAVING MACHINE.
- NO STUNT DRIVING OR HORSEPLAY IS PERMITTED.

## SECTION 1 - SAFETY PRECAUTIONS

---

- NEVER ATTEMPT TO FREE A MACHINE STUCK IN SOFT GROUND OR ASSIST A MACHINE UP A STEEP HILL OR RAMP BY USING BOOM "LIFT", "TELESCOPE", OR "SWING" FUNCTIONS.
- NEVER ATTACH WIRE, CABLE, OR ANY SIMILAR ITEMS TO PLATFORM.
- DO NOT PLACE BOOM OR PLATFORM AGAINST ANY STRUCTURE TO STEADY PLATFORM OR SUPPORT STRUCTURES.
- DO NOT USE THE LIFT, SWING, OR TELESCOPE FUNCTIONS FOR THE BOOM, TO MOVE EITHER THE MACHINE OR OTHER OBJECTS.
- HYDRAULIC CYLINDERS SHOULD NEVER BE LEFT FULLY EXTENDED OR RETRACTED FOR ANY LENGTH OF TIME. ALWAYS "BUMP" CONTROL IN OPPOSITE DIRECTION SLIGHTLY WHEN FUNCTION BEING USED REACHES END OF TRAVEL. THIS APPLIES TO MACHINES IN OPERATION OR IN STOWED MODE.
- DO NOT OPERATE ANY MACHINE ON WHICH DANGER, WARNING, CAUTION OR INSTRUCTION PLACARDS OR DECALS ARE MISSING OR ILLEGIBLE.

- MACHINE MUST ALWAYS BE SHUT DOWN WHEN REFUELING. NO SMOKING IS MANDATORY. NEVER REFUEL DURING AN ELECTRICAL STORM. ENSURE THAT FUEL CAP IS CLOSED AND SECURE AT ALL OTHER TIMES.

---

### 1.7 TOWING AND HAULING

- DO NOT TOW A MACHINE EXCEPT IN AN EMERGENCY. SEE SECTION 6 FOR EMERGENCY TOWING PROCEDURES.
- LOCK TURNTABLE BEFORE TRAVELING LONG DISTANCES OR BEFORE HAULING MACHINE ON A TRUCK OR TRAILER.



## SECTION 2. PREPARATION AND INSPECTION

### 2.1 GENERAL

This section provides the necessary information needed by those personnel that are responsible to place the machine in operation readiness, and lists checks that are performed prior to use of the machine. It is important that the information contained in this section be read and understood before any attempt is made to operate the machine. Ensure that all the necessary inspections have been completed successfully before placing the machine into service. These procedures will aid in obtaining maximum service life and safe operation.

#### **⚠ IMPORTANT**

**SINCE THE MACHINE MANUFACTURER HAS NO DIRECT CONTROL OVER THE FIELD INSPECTION AND MAINTENANCE, SAFETY IS THE RESPONSIBILITY OF THE OWNER/OPERATOR.**

### 2.2 PREPARATION FOR USE

Before a new machine is put into operation it must be carefully inspected for any evidence of damage resulting from shipment and inspected periodically thereafter, as outlined in Delivery and Frequent Inspection (see section 2-3). During initial start-up and run, the unit should be thoroughly checked for hydraulic leaks. A check of all components should be made to ensure their security.

All preparation necessary to place the machine in operation readiness status is the responsibility of management personnel. Preparation requires good common sense, (i.e. telescope works smoothly and brakes operate properly) coupled with a series of visual inspections. The mandatory requirements are given in the Daily Walk Around Inspection (see section 2-4).

It should be assured that the items appearing in the Delivery and Frequent Inspection and Functional Check are complied with prior to putting the machine into service.

### 2.3 DELIVERY AND FREQUENT INSPECTION

**NOTE:** *This machine requires periodic safety and maintenance inspections by an authorized JLG Dealer. A decal located on the turntable provides a place to record (stamp) inspection dates. Check decal and notify dealer if inspection is overdue.*

An annual inspection shall be performed on the aerial platform no later than thirteen (13) months from the date of the prior annual inspection. The inspection shall be performed by person(s) qualified as a mechanic on the specific make and model of the aerial platform.

The following checklist provides a systematic inspection to assist in detecting defective, damaged, or improperly installed parts. The checklist denotes the items to be inspected and conditions to examine.

Frequent inspection shall be performed every 3 months or 150 hours whichever comes first, or more often when required by environment, severity, and frequency of usage.

#### **Chassis**

1. Check front tire and wheel assemblies for loose or worn spindles, components and hardware for security, tires for wear and damage.
2. Check steering assembly for loose or bent tie rod, cylinder and hydraulic lines for leaks and security, and hardware for proper installation.
3. Check rear tire and wheel assemblies for security, tires for wear and damage.
4. Check drive hubs, hydraulic motors, brakes and hydraulic lines for damage and leaks.
5. Check oil level in drive hub by removing pipe plug on side and feeling for oil level. (Contact Service Personnel for assistance if needed).

**NOTE:** *Torque hubs should be one-half full of lubricant.*

6. Check counterbalance, flow divider valves, hydraulic swivel assembly and lines for visible damage, evidence of leakage, and security and electrical connections for corrosion and tightness.
7. Check extending axle assemblies for evidence of leakage and security; pressure lines for abnormal chafing drive hubs, hydraulic motors, brakes and hydraulic lines for damage and leaks.
8. Check extending axles for visible damage and loose or missing parts.

## SECTION 2 - PREPARATION AND INSPECTION

---

### Turntable

---

1. Check turntable and turntable lock for damage, loose or missing parts, and security. Check swing drive hub, hydraulic motor, and brake for damage, loose or missing parts, hydraulic lines and component housings for evidence of leakage; pinion for proper mesh with swing gear.
2. Check swing bearing for damage, wear, lubrication and loose or missing bearing bolts.
3. Check solenoid valves and hydraulic lines for damage, leakage, security and electrical connections for tightness and evidence of corrosion.
4. Check ground controls for damage, loose or missing parts, security, electrical connections for evidence of corrosion and tightness and wiring for insulation damage. Assure that all switches function properly.
5. Check battery for damage, loose or missing vent caps, electrical connections for tightness, and evidence of corrosion, holddown brackets for tightness, and electrolyte for proper water level. Add only clean distilled water to battery.
6. Check engine and accessories for damage, loose or missing parts, leakage and security. Check throttle solenoid and linkage for damage, electrical connections for tightness, and evidence of corrosion and wiring for insulation damage.
7. Check fuel lines for damage, leakage and security.
8. Check all access doors for damage, proper operation of latches, props and security.
9. Check fuel tank for damage, leakage and filler cap for security.
10. Check hydraulic reservoir and hydraulic lines for damage, leakage and security.

**NOTE:** *JLG recommends replacing the hydraulic filter element after the first 50 hours of operation and then every 300 hours thereafter, unless system indicator require earlier replacement.*

11. Check all cylinder pin and shaft retaining hardware for security and wear.

12. Check all electrical cables for defects, damage, loose or corroded connections.

### Boom

---

1. Check all cylinder pin and shaft retaining hardware for security and wear.
2. Check hydraulic lines, electrical cable and track assemblies for damage, missing parts and security.
3. Check lift cylinder and cross pins and hydraulic lines for damage, wear, leakage and security.
4. Check boom pivot pins for damage, wear, and security.
5. Check hydraulic line and electrical cable track assembly for visible damage, loose or missing parts, and security.
6. Check boom for damage, missing parts and security.
7. Check boom wear pads for damage, wear and security.
8. Check boom telescope cylinder and cross pins and hydraulic lines for damage, wear, leakage and security.
9. Check platform leveling cylinder and cross pins and hydraulic lines for damage, wear, leakage and security.
10. Check boom/platform pivot pin for damage, wear and security.
11. Check horizontal and capacity limit switches mounted on turntable for security of mounting, damage to switch arms and rollers; and for debris.
12. Check boom tape for correct length and tearing or defacing at any point.

### Extend-A-Reach

---

1. Check the slave cylinder, weld link and cross pins, and lines for visible damage, wear, lubrication, evidence of leakage, and security.
2. Check extend-a-reach for visible damage, loose or missing parts, and security.
3. Check hydraulic lines and electrical cable for damage, missing parts and security.

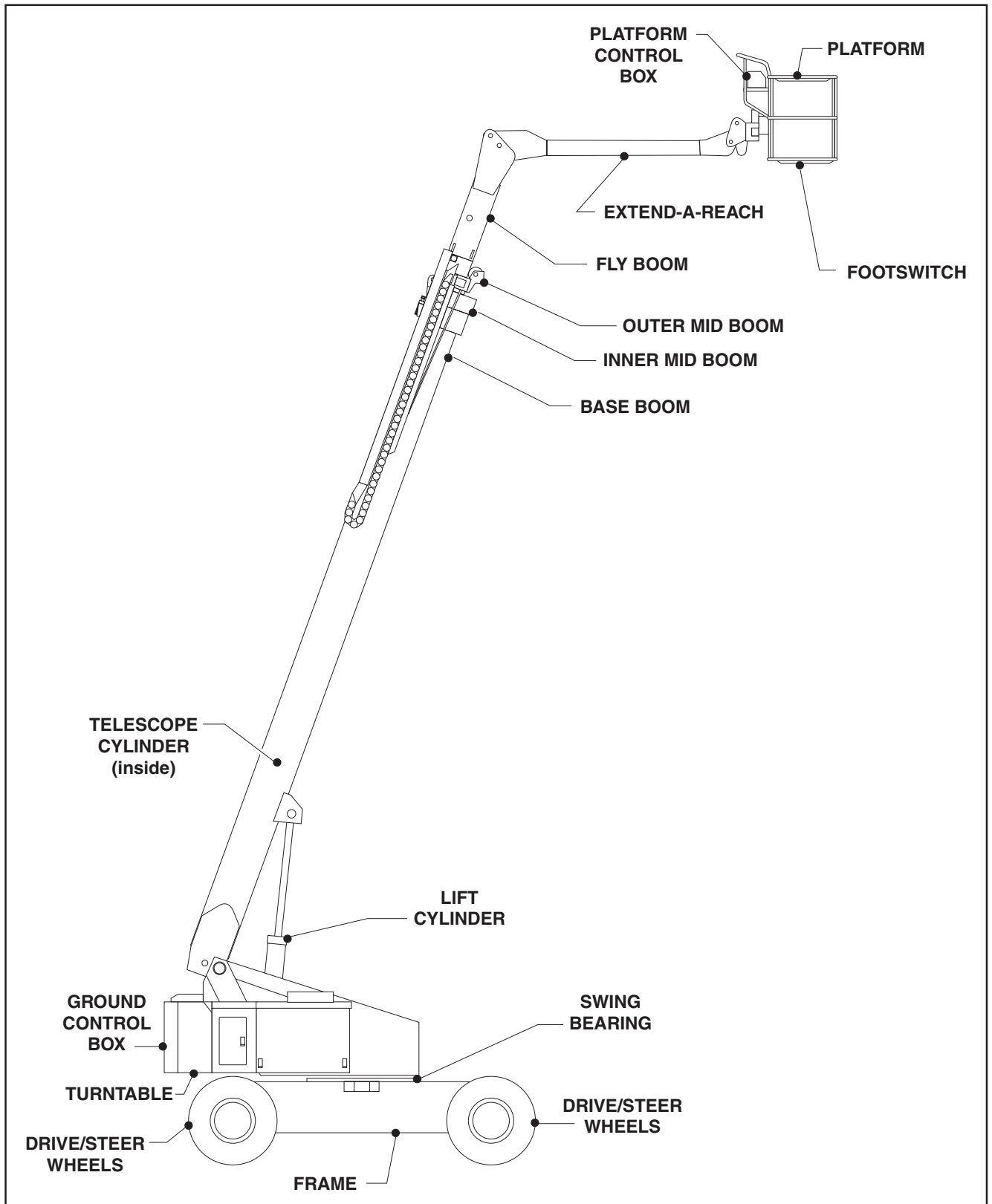

Figure 2-1. Machine Nomenclature.

### Platform

---

1. Check platform and control console for damage, loose or missing parts, and security.
2. Check control switches and levers for damage, loose or missing parts and security. Assure that levers function properly.
3. Check control switches, levers and electrical connections for tightness and evidence of corrosion, and wiring for defects and chafing damage. Assure that switches function properly.
4. Check capacity indicator for correct operation, any damage and that decals are not defaced. Ensure indicator dial is zeroed with boom at horizontal and indicator dial moves in accordance with boom angle.
5. Check access gate hinges and latch for proper operation, damage and security.
6. Check platform rotator mechanism for proper operation, damage, security. Check hydraulic lines for leakage, damage and security.

**NOTE:** Check all *DANGER, WARNING, CAUTION* and *INSTRUCTION* placards for legibility and security on the entire machine.

### Torque Requirements

---

The Torque Chart (Figure 2-4.) consists of standard torque values based on bolt diameter and grade, also specifying dry and wet torque values in accordance with recommended shop practices. This chart is provided as an aid to the operator in the event he/she notices a condition that requires prompt attention during the walk-around inspection or during operation, until the proper service personnel can be notified. The Service and Maintenance manual provides specific torque values and periodic maintenance

procedures with a listing of individual components. Utilizing this Torque Chart in conjunction with the preventive maintenance section in the Service and Maintenance manual will enhance safety, reliability, and performance of the machine.

---

## 2.4 DAILY WALK-AROUND INSPECTION

It is the operator's responsibility to inspect the machine before the start of each workday. It is recommended that each operator inspect the machine before operation, even if the machine has already been put into service under another operator. This Daily Walk-Around Inspection is the preferred method of inspection. (See Figure 2-2.)

In addition to the Daily Walk-Around Inspection, be sure to include the following as part of the daily inspection:

1. Overall cleanliness.

Check all standing surfaces for oil, fuel and hydraulic oil spillage and foreign objects. Ensure overall cleanliness.

2. Placards.

Keep all information and operating placards clean and unobstructed. Cover when spray painting or shot blasting to protect legibility.

3. Operator's and Safety Manual.

Ensure a copy of this manual and the ANSI A92.5-1992 Responsibilities are enclosed in the manual storage box.

4. Machine Log.

Ensure a machine operating record or log is kept, check to see that it is current and that no entries have been left uncleared, leaving machine in an

5. Start each day with a full fuel tank.

**⚠ WARNING**

TO AVOID INJURY, DO NOT OPERATE A MACHINE UNTIL ALL MALFUNCTIONS HAVE BEEN CORRECTED. USE OF A MALFUNCTIONING MACHINE IS A SAFETY VIOLATION.

TO AVOID POSSIBLE INJURY, BE SURE MACHINE POWER IS "OFF" DURING WALK-AROUND INSPECTION.

**NOTE:** Check boom horizontal limit switch for proper operation and security, both visually and manually. Switch must shut down high engine and high drive speed when boom is raised above horizontal:

6. Check platform footswitch for proper operation. Switch must be released to start engine and depressed to operate machine.
7. Check that drive brakes hold when machine is driven up a grade and stopped.

**NOTE:** On new machines, those recently overhauled, or after changing hydraulic oil, operate all systems a

*minimum of two complete cycles and recheck oil level in reservoir.*

**NOTE:** Hydraulic oils must have anti-wear qualities at least to API Service Classification GL-3, and sufficient chemical stability for mobile hydraulic system service. JLG Industries recommends Mobilfluid 424 hydraulic oil, which has an SAE viscosity index of 152 or Kendall Hyken 052 hydraulic oil, which has an SAE viscosity of 10W-20 and viscosity index of 152.

*When temperatures remain consistently below -7 degrees C., JLG Industries recommends the use of Mobil DTE 11.*

*Aside from JLG recommendations, it is not advisable to mix oils of different brands or types, as they may not contain the same required additives or be of comparable viscosities. If use of hydraulic oil other than Mobilfluid 424 is desired, contact JLG industries for proper recommendations.*

8. Assure that all items requiring lubrication are serviced. Refer to Lubrication Chart, Figure 2-3., for specific requirements.

SECTION 2 - PREPARATION AND INSPECTION

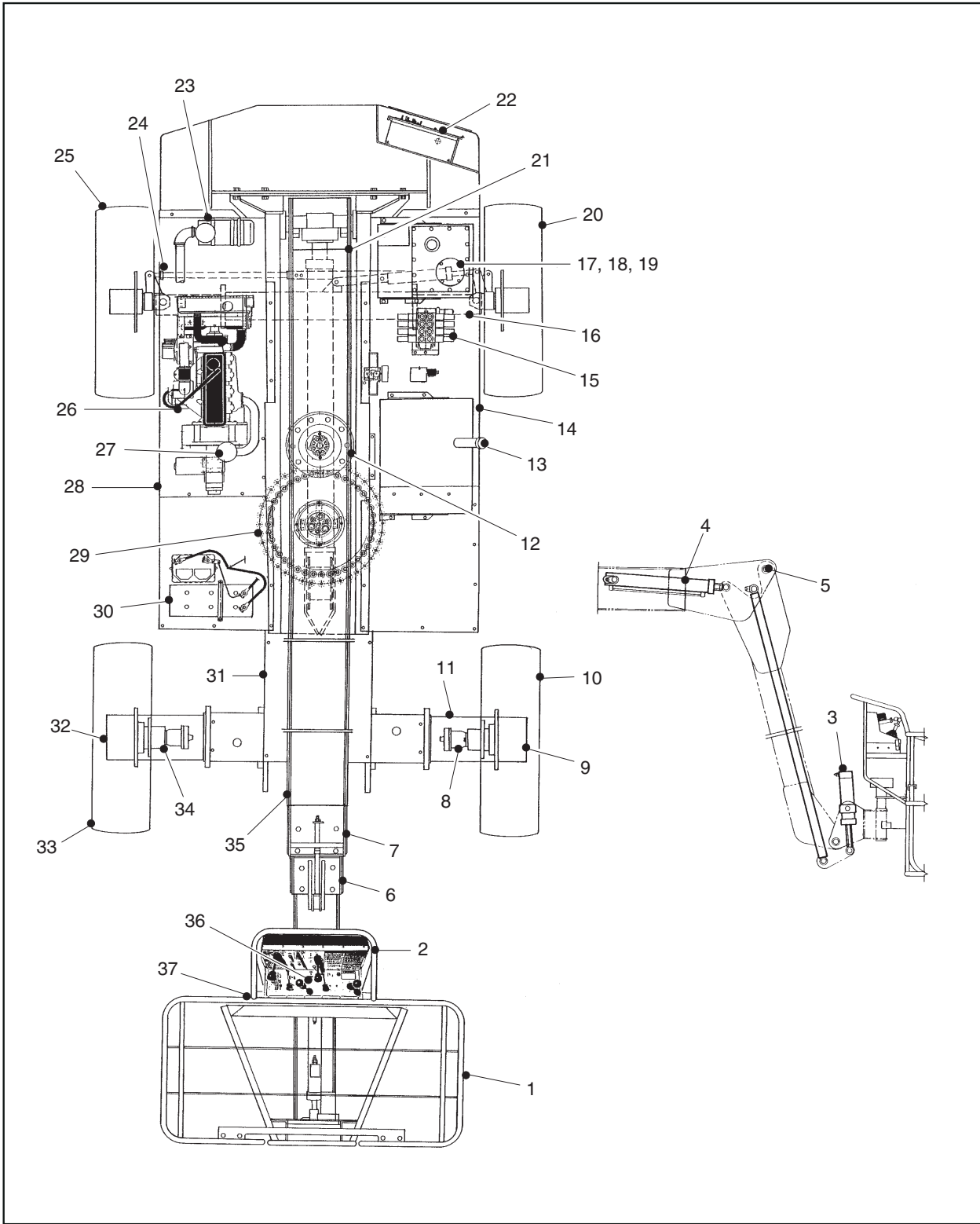

Figure 2-2. Daily Walk-Around Inspection (Sheet 1 of 3)

**GENERAL**

Begin the "Walk-Around Inspection" at Item 1, as noted on the diagram. Continue to the right (counterclockwise viewed from top) checking each item in sequence for the conditions listed in the "Walk-Around Inspection Checklist".

**⚠ WARNING**

TO AVOID INJURY, DO NOT OPERATE A MACHINE UNTIL ALL MALFUNCTIONS HAVE BEEN CORRECTED. USE OF A MALFUNCTIONING MACHINE IS A SAFETY VIOLATION. TO AVOID POSSIBLE INJURY, BE SURE MACHINE POWER IS "OFF" DURING WALK-AROUND INSPECTION.

**NOTE:** Do not overlook visual inspection of chassis underside. Checking this area often results in discovery of conditions which could cause extensive machine damage.

1. **Platform Assembly** - No loose or missing parts, no visible damage. Lock bolts in place. Footswitch in good working order, not modified, disabled or blocked. Check area of fly boom nose section above and under platform slave level cylinder for accumulation of foreign material. Remove any foreign material present.
2. **Platform Control Console** - Switches and levers return to neutral and are properly secured, no loose or missing parts, no visible damage, decals/placards secure and legible, control marking legible.
3. **Slave Leveling Cylinder, Extend-A-Reach** - Properly secured, no visible damage, no evidence of leakage.
4. **Extend-A-Reach Lift Cylinder** - Properly secured, no visible damage, or signs of leakage, evidence of proper lubrication.
5. **Extend-A-Reach Pivot** - No loose, damaged, or missing parts, evidence of proper lubrication.
6. **Hose and Cable Guards/Clamps** - Properly secured, no visible damage.
7. **Power Track** - No loose, damaged or missing parts, no visible damage.
8. **Drive Motor and Brake, Right Rear** - No visible damage, no evidence of leakage.
9. **Drive Hub, Right Rear** - No visible damage, no evidence of leakage.
10. **Wheel/Tire Assembly, Right Rear** - Properly secured, no loose or missing lug nuts, no visible damage.
11. **Extendable Axle** - Lock pins in place, properly secured. Check both sides.
12. **Swing Drive Motor and Brake** - No visible damage, no evidence of leakage.
13. **Fuel Supply** - Fuel filler cap secure. Tank - no visible damage; no evidence of leaks.
14. **Cowling and Latches** - All cowling and latches in working condition, properly secured, no loose or missing part.
15. **Control Valve Compartment** - No loose or missing parts; evidence of leakage; unsupported wires or hoses; damaged or broken wires.
16. **Extendable Axle** - Lock pins in place, properly secured. Check both sides.
17. **Hydraulic Oil Supply** - Recommended oil level in sight gauge. (Check level with cold oil, systems shut down, machine in stowed position) Cap in place and secure.
18. **Hydraulic Oil Filter Housing** - Housing secure; no visible damage or signs of leakage.
19. **Hydraulic Oil Breather** - Element in place, not clogged, no signs of overflow.
20. **Wheel/Tire Assembly, Right Front** - Properly secured, no loose or missing lug nuts, no visible damage.
21. **Turntable Springs** - Properly secured, no loose or missing nuts or bolts.
22. **Ground Controls** - Switches operable, no visible damage, decals secure and legible.
23. **Engine Air Filter** - No loose or missing parts, no visible damage, element clean.
24. **Tie Rod and Steering Linkage** - No loose or missing parts, no visible damage. Tie rod end studs locked.
25. **Wheel/Tire Assembly, Left Front** - Properly secured, no loose or missing lug nuts, no visible damage.

Figure 2-2. Daily Walk-Around Inspection (Sheet 2 of 3)

## SECTION 2 - PREPARATION AND INSPECTION

---

- |   |  |
|---|--|
| 26. <b>Engine Oil Supply</b> - Full mark on dipstick; filler cap secure.  | 32. <b>Drive Hub, Left Rear</b> - No visible damage, no evidence of leakage.   |
| 27. <b>Muffler and Exhaust System</b> - Properly secured, no evidence of leakage.   | 33. <b>Wheel/Tire Assembly, Left Rear</b> - Properly secured, no loose or missing lug nuts, no visible damage.                         |
| 28. <b>Cowling and Latches, Right Side</b> - All cowling and latches in working condition, properly secured, no loose or missing part.  | 34. <b>Drive Motor and Brake, Left Rear</b> - No visible damage, no evidence of leakage.   |
| 29. <b>Turntable Bearing and Pinion</b> - No loose or missing hardware; no visible damage, evidence of proper lubrication. No evidence of loose bolts or looseness between bearing and structure. | 35. <b>Boom Sections</b> - No visible damage; wear pads secure. All cylinders - rod end shafts and barrel-end shafts properly secured. |
| 30. <b>Battery</b> - Proper electrolyte levels; cables tight, no visible damage or corrosion.   | 36. <b>Rotator and Motor</b> - Properly secured, no visible damage, no evidence of leakage.  |
| 31. <b>Frame</b> - No visible damage, no loose or missing hardware (top and underside).   | 37. <b>Platform Pivot and Slave Cylinder Attach Pins</b> - Properly secured; evidence of proper lubrication where applicable.          |

Figure 2-2. Daily Walk-Around Inspection (Sheet 3 of 3)



## 2.5 DAILY FUNCTIONAL CHECK

### **⚠ WARNING**

THE LOAD MANAGEMENT SYSTEM AND THE AXLES (PROPER EXTENSION AND RETRACTION) MUST BE CHECKED PRIOR TO ANY OTHER SYSTEMS AND/OR FUNCTIONS.

A functional check of all systems should be performed, once the walk-around inspection is complete, in an area free of overhead and ground level obstructions. First, using the ground controls, check all functions controlled by the ground controls. Next, using the platform controls, check all functions controlled by the platform controls.

### **⚠ WARNING**

TO AVOID SERIOUS INJURY, DO NOT OPERATE MACHINE IF ANY CONTROL LEVERS OR TOGGLE SWITCHES CONTROLLING PLATFORM MOVEMENTS DO NOT RETURN TO THE OFF OR NEUTRAL POSITION WHEN RELEASED.

TO AVOID COLLISION AND INJURY IF PLATFORM DOES NOT STOP WHEN A CONTROL SWITCH OR LEVER IS RELEASED, REMOVE FOOT FROM FOOTSWITCH OR USE EMERGENCY STOP TO STOP THE MACHINE.

**NOTE:** Perform checks from ground controls first, then from platform controls.

1. Axle Extension System.
  - a. Remove pins from steer cylinder and tie rod of rear axle.
  - b. Activate hydraulic system from ground controls.
  - c. Using the controls on the frame, lower the jack cylinder to raise the rear axle. When wheels are off the ground, extend axle completely by moving axle switch to the left.
  - d. Reinstall the pins in the steer cylinder and tie rod and lower the rear axle by raising the jack cylinder completely.
  - e. Remove the pins from the steer cylinder and tie rod of the front axle.
  - f. Using the controls on the frame, lower the jack cylinder to raise the front axle. When the wheels are off the ground, extend the axle completely by moving the axle switch to the left. The green AXLES SET indicator light will illuminate when the axles are fully extended.

- g. Reinstall the pins in the steer cylinder and tie rod, and lower the front axle by raising the jack cylinder completely.
  - h. Shut down the hydraulic system as required.
2. Load Management System Functional Check.
    - a. Activate the hydraulic system from the ground controls. The blue light should illuminate when the SELECT SWITCH is in the ground position, the EMERGENCY STOP switch is pulled out, and the boom is retracted.
    - b. With the boom fully retracted, raise the boom to horizontal.
    - c. Position the toggle switch located on the right side of the ground control box to the P position and hold.
    - d. Extend the boom until the red marking band on the inner mid section is exposed from the base section. The red light should illuminate at this point.
    - e. Continue extending the boom until the white marking band on the inner mid section is exposed from the base section. The red light should blink and an audible alarm sound. Also the telescope out and lift down will not function in this mode. Release the toggle switch.
    - f. Extend the boom. The boom must stop on the white band on the mid boom section. Release the toggle switch.
    - g. Retract the boom until tele out will function. The system is now reset.
    - h. Position the toggle switch to the M position and hold.
    - i. Repeat step e.

### **⚠ WARNING**

#### TIPOVER HAZARD

IF THE RED LIGHT DOES NOT BLINK, THE ALARM DOES NOT SOUND, THE BOOM CONTINUES TO TELESCOPE BEYOND SECOND MARKING BAND, IF THE BOOM CAN BE LOWERED, RETRACT THE BOOM, IMMEDIATELY SHUT DOWN MACHINE AND CONTACT A QUALIFIED SERVICE PERSON.

3. Drive forward and reverse; check for proper operation.
4. Steer left and right; check for proper operation.
5. Check rear steer left and right for proper operation.

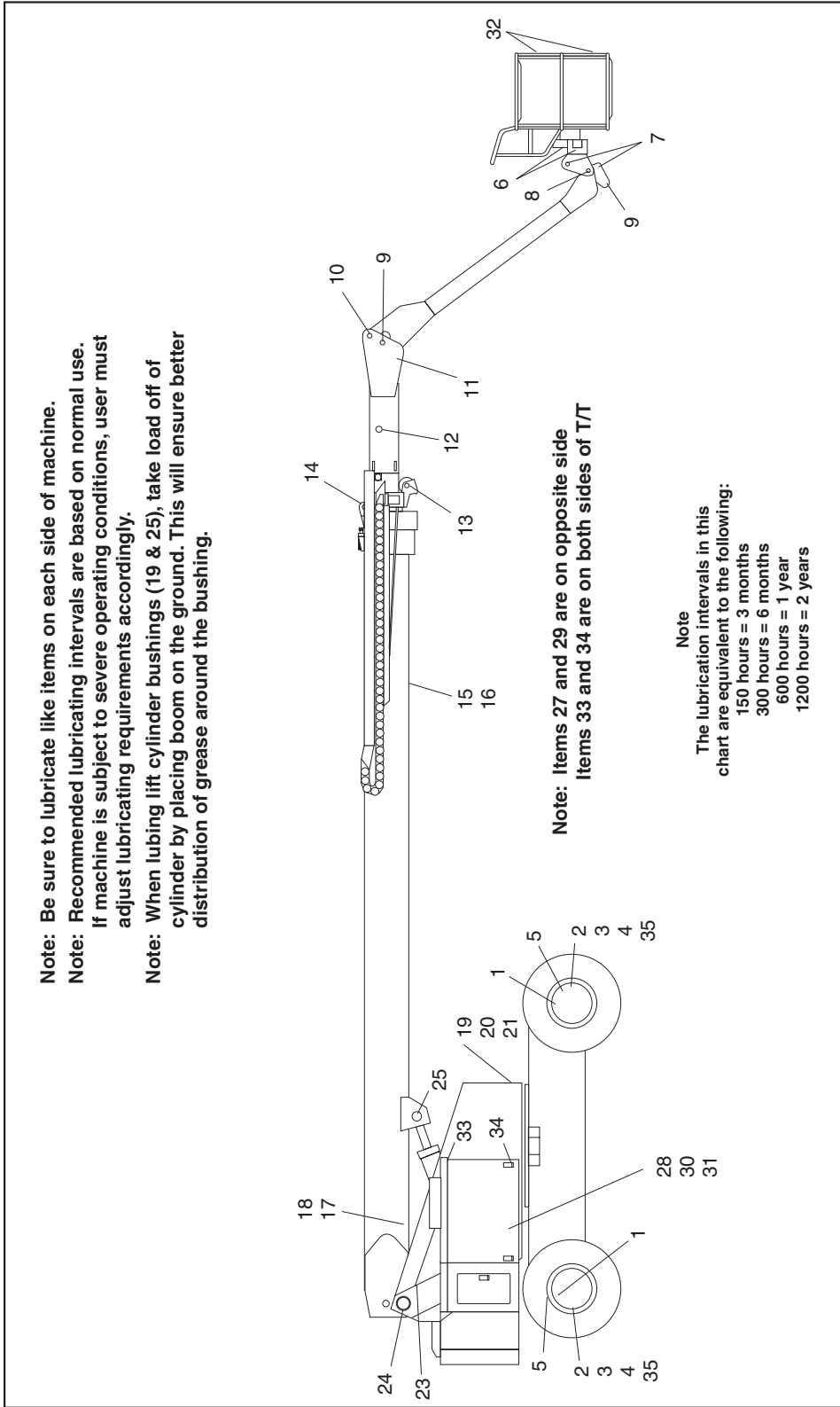

Figure 2-3. Lubrication Chart (Sheet 1 of 2)

## SECTION 2 - PREPARATION AND INSPECTION

Index No.	Component	Number/Type Lube Points	Lube & Method	Interval Hours	Comments
1	Wheel Drive Hubs	Fill/Drain Plugs	EPGL (SAE 90)	150/1200	Check Every 150 Hours Change Every 1200 Hours
2	Steer Cylinders - Rod End	2 Grease Fitting	MPG - Pressure Gun	150	
3	Steer Cylinders - Barrel End	2 Grease Fittings	MPG - Pressure Gun	150	
4	King Pins	4 Grease Fittings	MPG - Pressure Gun	150	
5	Tie Rods	4 Grease Fitting	MPG - Pressure Gun	150	
6	Rotary Platform Stand Rotary Worm Gear	2 Grease Fittings N/A	MPG - Pressure Gun MPG - Brush	150 150	Remove Cover to Grease
7	Platform Level cylinder	3 Grease Fittings	MPG - Pressure Gun	150	
8	Platform Pivot Pin	1 Grease Fitting	MPG - Pressure Gun	150	
9	Link Level Pin	2 Grease Fittings	MPG - Pressure Gun	150	
10	E-A-R Pivot Pin	1 Grease Fitting	MPG - Pressure Gun	150	
11	E-A-R Lift Cylinder - Rod End	1 Grease Fitting	MPG - Pressure Gun	150	
12	E-A-R Lift Cylinder - Barrel End	1 Grease Fitting	MPG - Pressure Gun	150	
13	Sheave Pin - Fly Extend	1 Grease Fitting	MPG - Pressure Gun	150	
14	Sheave Pin - Upper Aux.	1 Grease Fitting	MPG - Pressure Gun	150	
15	Tele Cyl. Sheave Pin	1 Grease Fitting	MPG - Pressure Gun	150	Extend boom until grease fitting is accessible thru hole in fly sec.
16	Boom Chains	N/A	Chain Lube/Hot Oil Dip	1200	Extend and Retract Chains
17	Sheave Pin - Fly Retract	2 Grease Fittings	MPG - Pressure Gun	150	Extend boom until fitting is accessible thru hole in fly
18	Sheave Pin - Outer-Mid Retract	2 Grease Fittings	MPG - Pressure Gun	150	Extend boom until fitting is accessible thru hole in fly
19	Lift Cylinder - Barrel End	1 Grease Fitting	MPG - Pressure Gun	150	Remote Access
20	Master Cylinder - Barrel End	1 Grease Fitting	MPG - Pressure Gun	150	Remote Access
21	Swing Bearing	1 Grease Fitting	MPG - Pressure Gun	150	Remote Access. Lube, rotate 180°, lube again.
22	Swing Bearing Gear	N/A	MPG - Brush	150	
23	Master Cylinder - Rod End	1 Grease Fitting	MPG - Pressure Gun	150	
24	Boom Pivot Bearings	2 Grease Fittings	MPG - Pressure Gun	150	
25	Lift Cylinder - Rod End	1 Grease Fitting	MPG - Pressure Gun	150	
26	Load Moment Pivot Pins	1 Grease Fitting	MPG - Pressure Gun	150	Position boom over side for access under turntable
27	Hydraulic Filter - Function Pump	N/A	N/A	50/300	Replace after first 50 hrs. of operation, then every 300 hrs. thereafter
28	Hydraulic Filter - Drive Pump	N/A	N/A	50/300	Replace after first 50 hrs. of operation, then every 300 hrs. thereafter
29	Hydraulic Fluid	Fill Cap	HO	10/1200	Check oil daily. Change oil every 1200 hrs
30	Engine Crankcase	Fill Cap/Drain Plug	EO - SAE30	10/300	Check oil daily. Change oil every 300 hrs.
31	Engine Oil Filter	N/A	Replaceable Cartridge	300	
32	Platform Door Hinges	2 Grease Fittings	MPG - Pressure Gun	150	
33	Access Door Hinges	N/A	SAE10 - Oil Can	150	As Needed
34	Access Door Latches	N/A	SAE10 - Oil Can	150	As Needed
35	Axle Beams	N/A	MPG - Brush	600	As Needed

Key to Lubricants: MPG - Multipurpose Grease  
EPGL - Extreme Pressure Gear Lubricant  
HO - Hydraulic Fluid  
EO - Engine Oil

**Figure 2-3. Lubrication Chart (Sheet 2 of 2)**

## SECTION 2 - PREPARATION AND INSPECTION

---

6. Check platform rotator for smooth operation and assure platform will rotate 90 degrees in both directions from centerline of boom. Raise, lower, and swing boom to LEFT and RIGHT a minimum of 45 degrees (Cycle function several times.) Check for smooth elevation and swing motion.
  7. Raise and lower Extend-A-Reach (Cycle functions several times). Check for smooth elevation and swing motion.
  8. Telescope boom in and out several cycles at various degrees of elevation lengths. Check for smooth telescope operation.
  9. Check that platform automatic self-leveling system functions properly during raising and lowering of the boom.
  10. Check platform level adjustment system for proper operation.
- NOTE:** Turntable lock is on turntable facing platform. To disengage lock, pull snap pin from lock pin, lift lock pin up to unlock turntable. Return snap pin to lock pin to hold lock pin in the disengaged position. Reverse procedure to engage turntable lock.
11. Swing turntable to LEFT and RIGHT a minimum of 45 degrees. Check for smooth motion.
  12. With the aid of an assistant to monitor the CHASSIS OUT OF LEVEL indicator light on the platform control console, manually activate the indicator light by compressing any one of the three tilt indicator mounting springs. If the light does not illuminate, shut down machine and contact a qualified service technician before continuing operation.
  13. Footswitch.
    - a. Activate hydraulic system by depressing footswitch. Operate TELESCOPE and hold control. Remove foot from footswitch, motion should stop. If it does not, shut down machine and contact a certified JLG service technician.
    - b. With footswitch depressed, operate LIFT and hold control. Remove foot from footswitch, motion should stop. If it does not, shut down machine and contact a certified JLG service technician.
    - c. With engine power shut down, depress the footswitch. Attempt to start engine. Engine should not attempt to start when footswitch is depressed. If starter engages or engine turns over, shut down machine and contact a certified JLG service technician.
14. Auxiliary Power.

Operate each function control switch (e.g. TELE, LIFT and SWING) to assure that they function in both directions using auxiliary power instead of engine power.
  15. Ground Controls.

Place GROUND/PLATFORM SELECT switch to GROUND. Start engine. Platform controls should not operate.

### IMPORTANT

FOOTSWITCH MUST BE ADJUSTED SO THAT FUNCTIONS WILL OPERATE WHEN PEDAL IS APPROXIMATELY AT ITS CENTER OF TRAVEL. IF SWITCH OPERATES WITHIN LAST 1/4" OF TRAVEL, TOP OR BOTTOM, IT SHOULD BE ADJUSTED.

---

## 2.6 TORQUE REQUIREMENTS

The Torque Chart (Figure 2-4.) consists of standard torque values based on bolt diameter and grade, also specifying dry and wet torque values in accordance with recommended shop practices. This chart is provided as an aid to the operator in the event a condition is noticed that requires prompt attention during the walk-around inspection or during operation until the proper service personnel can be notified. The Service and Maintenance manual provides specific torque values and periodic maintenance procedures with a listing of individual components. Utilizing this Torque Chart in conjunction with the preventive maintenance section in the Service and Maintenance manual, will enhance safety, reliability and performance of the machine.

---

## 2.7 BATTERY MAINTENANCE

**⚠ WARNING**

TO AVOID INJURY FROM AN EXPLOSION, DO NOT SMOKE OR ALLOW SPARKS OR A FLAME NEAR BATTERY DURING SERVICING.

ALWAYS WEAR EYE PROTECTION WHEN SERVICING BATTERIES.

### **Battery Maintenance**

---

1. The battery is maintenance free except for occasional battery terminal cleaning, as noted in the following.
2. Remove battery cables from each battery post one at a time, negative first. Clean cables with acid neutralizing solution (e.g. baking soda and water or ammonia) and wire brush. Replace cables and/or cable clamp bolts as required.
3. Clean battery post with wire brush then re-connect cable to post. Coat non-contact surfaces with mineral grease or petroleum jelly (Vaseline).
4. When all cables and terminal posts have been cleaned, ensure all cables are properly positioned and are not pinched. Close battery compartment cover.

SECTION 2 - PREPARATION AND INSPECTION

VALUES FOR ZINC PLATED BOLTS ONLY												UNPLATED CAP SCREWS	
SIZE	THD	BOLT DIA. (IN.)	THREAD STRESS AREA (SQ. IN.)	SAE GRADE 5 BOLTS & GRADE 2 NUTS			SAE GRADE 8 BOLTS & GRADE 8 NUTS			UNBRAKO 1960 SERIES SOCKET HEAD CAP SCREW WITH LOC-WEL PATCH			
				CLAMP LOAD (LB.)	TORQUE		CLAMP LOAD (LB.)	TORQUE		CLAMP LOAD (LB.)	TORQUE		
				(DRY OR LOC. 263) LB. IN.	(LUB.) LB. IN.	(LOCTITE 262) LB. IN.	(DRY OR LOC. 263) LB. IN.	(LUB.) LB. IN.	(LOCTITE 262) LB. IN.	(LOCTITE 242 OR 271) LB. IN.	(as received) LB. FT.		
4	40	0.1120	0.00604	8	6	—	12	9	—	—	—	—	
48	48	0.00661	420	9	7	—	13	10	—	—	—	—	
6	32	0.1380	0.00909	16	12	—	23	17	—	—	—	—	
40	40	0.01015	610	18	13	—	25	19	—	—	—	—	
32	32	0.1640	0.01400	30	22	—	41	31	—	—	—	—	
36	36	0.01474	940	31	23	—	43	32	—	—	—	—	
10	24	0.01750	1120	43	32	—	60	45	—	—	—	—	
32	32	0.02000	1285	49	36	—	68	51	—	—	—	—	
1/4	20	0.2500	0.0318	96	75	—	144	108	—	—	160	13	
	28		0.0364	120	86	—	168	120	—	—	185	14	
				LB. FT.	LB. FT.	LB. FT.	LB. FT.	LB. FT.	LB. FT.	LB. FT.	LB. FT.		
5/16	18	0.3125	0.0524	17	13	16	19	19	16	22	30	25	
24	24	0.0580	3700	19	14	17	21	21	25	20	25	30	
3/8	16	0.3750	0.0775	30	23	28	35	35	45	35	40	50	
24	24	0.0878	5600	35	25	32	40	40	7900	50	35	45	
7/16	14	0.4375	0.1063	50	35	45	55	55	9550	70	55	63	
20	20	0.1187	7550	55	40	50	60	60	10700	80	60	70	
1/2	13	0.5000	0.1419	75	55	68	85	85	12750	110	80	96	
20	20	0.1599	10700	90	65	80	100	100	14400	120	90	108	
9/16	12	0.5625	0.1820	110	80	98	120	120	16400	150	110	139	
18	18	0.2030	12950	120	90	109	135	135	18250	170	130	154	
5/8	11	0.6250	0.2260	14400	150	110	135	165	20350	220	170	180	
18	18	0.2560	16300	170	130	153	190	190	23000	240	180	204	
3/4	10	0.7500	0.3340	21300	260	200	240	285	30100	380	280	301	
16	16	0.3730	23800	300	220	268	330	330	33600	420	320	336	
7/8	9	0.8750	0.4620	29400	430	320	386	475	41600	600	460	485	
14	14	0.5090	32400	470	350	425	520	520	45800	660	500	534	
1	8	1.000	0.6060	38600	640	480	579	675	51500	900	680	687	
12	12	0.6630	42200	700	530	633	735	735	59700	1000	740	796	
1-1/8	7	1.1250	0.7630	42300	800	600	714	840	68700	1280	960	1030	
12	12	0.8560	47500	880	660	802	925	925	77000	1440	1080	1155	
1-1/4	7	1.2500	0.9590	53800	1120	840	1009	1175	87200	1820	1360	1453	
12	12	1.0730	59600	1240	920	1118	1300	1300	96600	2000	1500	1610	
1-1/2	6	1.5500	1.1550	64100	1460	1100	1322	1525	104000	2380	1780	1907	
12	12	1.3150	73000	1680	1260	1506	1750	1750	118100	2720	2040	2165	
1-1/2	6	1.4050	78000	1940	1460	1755	2025	2025	126500	3160	2360	2530	
12	12	1.5800	87700	2200	1640	1974	2300	2300	142200	3560	2660	2844	



SAE GRADE 8



SAE GRADE 5

Note: These torque values do not apply to cadmium plated fasteners.

Figure 2-4. Torque Chart

## SECTION 3. USER RESPONSIBILITIES AND MACHINE CONTROL

---

### 3.1 GENERAL

#### **⚠ IMPORTANT**

SINCE THE MANUFACTURER HAS NO DIRECT CONTROL OVER MACHINE APPLICATION AND OPERATION, CONFORMANCE WITH GOOD SAFETY PRACTICES IN THESE AREAS IS THE RESPONSIBILITY OF THE USER AND HIS/HER OPERATING PERSONNEL.

This section provides the necessary information needed to understand control functions. Included in this section are the operating characteristics and limitations, and functions and purposes of controls and indicators. It is important that the user and/or operator read and understand the proper procedures before operating the machine. These procedures will aid in obtaining optimum aerial platform service and safe operation.

---

### 3.2 PERSONNEL TRAINING

The aerial platform is a personnel handling device; therefore it is essential that it be operated and maintained only by authorized and qualified personnel who have demonstrated that they understand the proper use and maintenance of the machine. It is important that all personnel who are assigned to and responsible for the operation and maintenance of the machine undergo a thorough training program and check out period in order to become familiar with the characteristics prior to operating the machine.

In addition, personnel operating the machine should be familiar with ANSI standard A92.5-1992 Responsibilities Section. This outlines the responsibilities of the owners, users, operators, lessors and lessees concerning safety, training, inspection, maintenance, application and operation.

Persons under the influence of drugs or alcohol or who are subject to seizures, dizziness or loss of physical control must not be permitted to operate the machine.

#### **Operator Training**

Operator training must include instruction in the following areas:

1. Use and limitations of the platform controls, ground controls, emergency controls and safety systems.

2. Knowledge and understanding of this manual and of the control markings, instructions and warnings on the machine itself.
3. Knowledge and understanding of all safety work rules of the employer and of Country, Federal, State and local statutes, including training in the recognition and avoidance of potential hazards in the work place; with particular attention to the work to be performed.
4. Proper use of all required personnel safety equipment, in particular the wearing of a safety harness or other approved fall protection devices with a lanyard attached to the designated lanyard attach point on the platform at all times.
5. Sufficient knowledge of the mechanical operation of the machine to recognize a malfunction or potential malfunction.
6. The safest means to operate the machine where overhead obstructions, other moving equipment, and obstacles, depressions, holes, drop-offs, etc. on the supporting surface exist.
7. Means to avoid the hazards of unprotected electrical conductors.
8. Any other requirements of a specific job or machine application.

#### **Training Supervision**

Training must be done under the supervision of a qualified person in an open area free of obstructions until the trainee has developed the ability to safely control a machine in congested work locations.

#### **Operator Responsibility**

The operator must be instructed that he/she has the responsibility and authority to shut down the machine in case of a malfunction or other unsafe condition of either the machine or the job site and to request further information from his/her supervisor or an authorized JLG Distributor before proceeding.

**NOTE:** *Manufacturer or distributor will provide qualified persons for training assistance with first unit(s) delivered and thereafter as requested by the user or his/her personnel.*

### 3.3 OPERATING CHARACTERISTICS AND LIMITATIONS

#### General

A thorough knowledge of the operating characteristics and limitations of the machine is always the first requirement for any user, regardless of the user's experience with similar types of equipment.

#### Placards

Important points to remember during operation are provided at the control stations by DANGER, WARNING, CAUTION, IMPORTANT and INSTRUCTION placards. This information is placed at various locations for the express purpose of alerting personnel of potential hazards constituted by the operating characteristics and load limitations of the machine. See FOREWORD for definitions of the above placards.

#### Capacities

Raising boom above horizontal and/or extension of boom beyond retracted position with or without any load in platform, is based on the following criteria:

1. Machine is positioned on a smooth, firm and level surface.
2. Load is within manufacturer's rated design capacity.
3. All machine systems are functioning properly.
4. Proper tire pressure exists in the tires.
5. Machine is as originally equipped from JLG.

#### Stability

This machine as originally manufactured by JLG Industries Inc., when operated within its rated capacity on a smooth, firm and level supporting surface, and in accordance with the instructions provided on the machine and this manual, provides a stable machine for all platform positions.

Machine stability is based on two positions which are called FORWARD STABILITY and BACKWARD STABILITY. The machine's position of least forward stability is shown in Figure 3-1., and its position of least backward stability is shown in Figure 3-2.



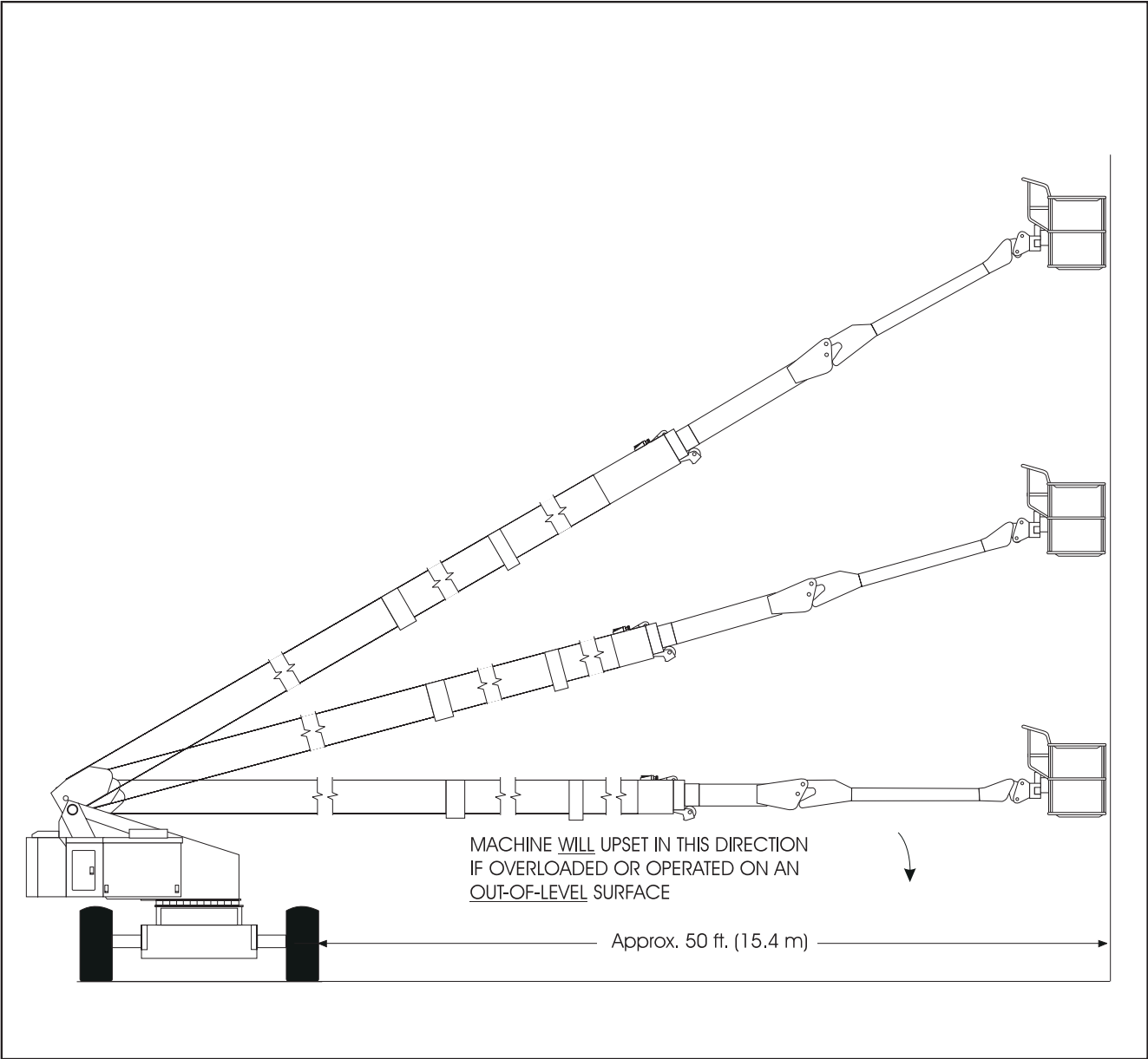

Figure 3-1. Position of Least Forward Stability

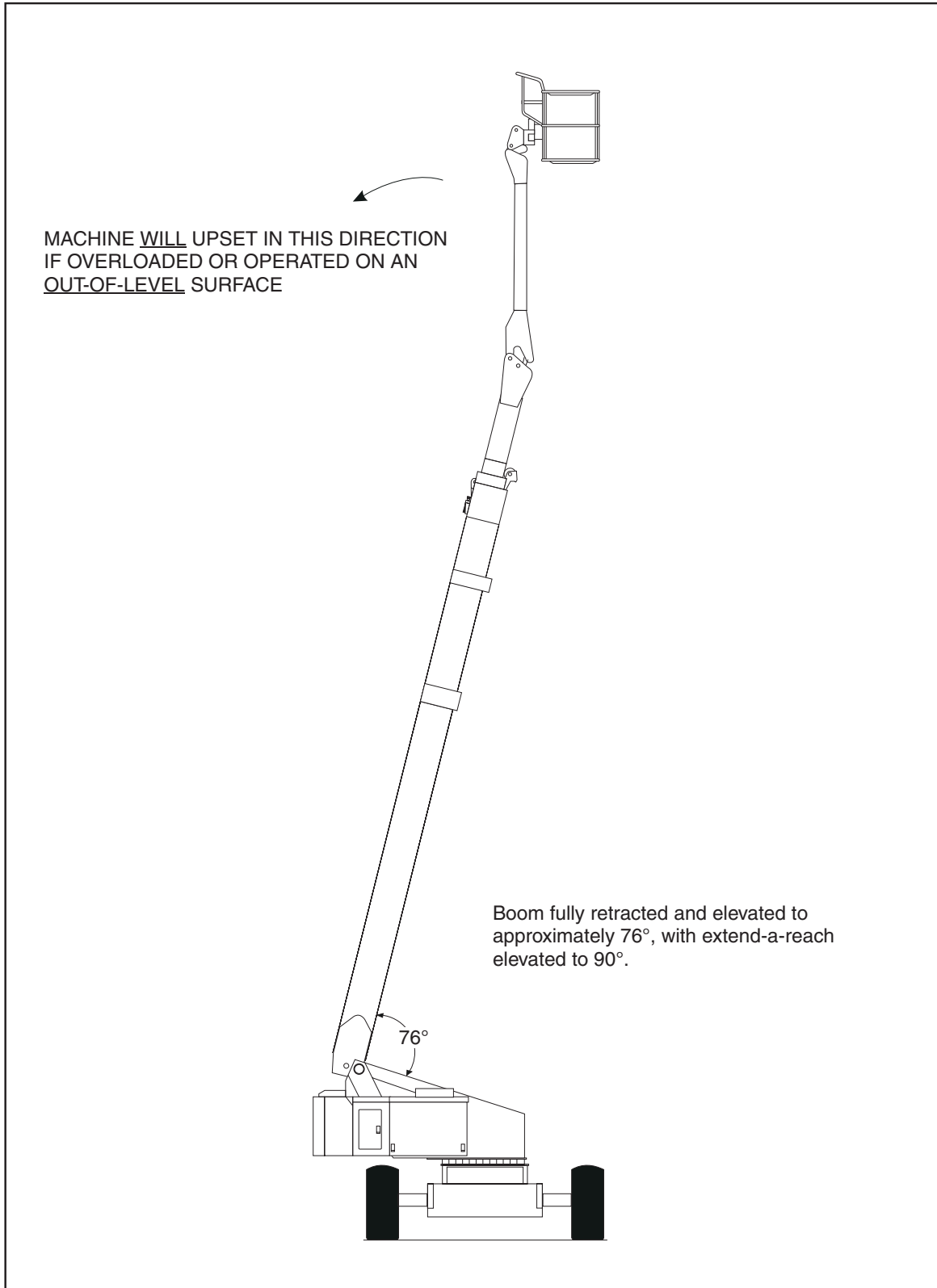

Figure 3-2. Position of Least Backward Stability

### 3.4 CONTROLS AND INDICATORS

#### Precision Control Governor

This control allows the engine to remain at idle until any function is activated, at which time the engine will accelerate to perform that function. Upon release of the function the engine will accelerate back to idle. High engine can only be obtained if the drive handle is placed in the extreme drive position, if the high engine switch is ON and the boom is horizontal or below.

#### Ground Controls

Some machines are equipped with control panels that use symbols to indicate control functions. Refer to Table 3-1 for these symbols and their corresponding functions.

#### WARNING

DO NOT OPERATE FROM THE GROUND STATION WITH PERSONNEL IN THE PLATFORM EXCEPT IN AN EMERGENCY.

PERFORM PRE-OPERATIONAL CHECKS AND INSPECTIONS FROM THE GROUND CONTROL STATION. WHEN PERSONNEL ARE IN THE PLATFORM, OPERATION OF THE BOOM WILL ONLY BE PERFORMED WITH THE PERMISSION OF THE PLATFORM OCCUPANT(S).

#### IMPORTANT

WHEN THE MACHINE IS SHUT DOWN THE MASTER/EMERGENCY STOP SWITCH MUST BE POSITIONED TO THE "OFF" POSITION TO PREVENT DRAINING THE BATTERY.

##### 1. Power / Emergency Stop Switch.

The two position POWER/EMERGENCY STOP switch furnishes battery power to the platform or ground control switches when station power is selected from the ground control panel. Push in to shut off the engine and remove power from the controls. The ground control emergency stop switch must be pulled out to operate the machine from either the Ground Control or Platform Control.

##### 2. Control Station Selector.

A three position, center off, key activated SELECT SWITCH supplies power to the platform control console when positioned to PLATFORM. With the switch in the GROUND position, power is shut off to the platform station, and only the controls on the ground control panel are operable.

**NOTE:** *With the Platform/Ground Select Switch in the center position, power is shut off to controls at both operating stations.*

#### WARNING

TO AVOID SERIOUS INJURY, DO NOT OPERATE MACHINE IF ANY CONTROL LEVERS OR TOGGLE SWITCHES CONTROLLING PLATFORM MOVEMENT DO NOT RETURN TO THE OFF POSITION WHEN RELEASED.

##### 3. Start Button.

The START button is a momentary contact, push button type switch that supplies electrical power to the starter solenoid, when the POWER/EMERGENCY STOP Switch is pulled out and the SELECT SWITCH is in the Ground position. Push and hold the button until the engine starts.

**NOTE:** *One of the capacity indicator lights should be illuminated at all times during operation. If no capacity lights are on, a bulb is probably burned out. Operation of the machine must be halted until the lights are working properly.*

##### 4. Capacity Indicator.

The capacity indicator displays to the operator the maximum rated platform capacity and the maximum radius for that capacity using colored lights and a reach diagram. The operator must not exceed the rated capacity or the rated radius for the load (personnel, tools, and supplies) shown on the indicator.

The blue light indicates operating within 500 lb. range. A steady red light indicates you have exceeded the machines operating radius. You must immediately stop and "LIFT UP" or "TELE IN" until the red light goes out. A blinking red light and a buzzer sounding indicates you have exceeded the platform load capacity (personnel, tools, and supplies) or operating radius. You must immediately stop and "LIFT UP" or "TELE IN" until the red light goes out and the buzzer stops. Check to make sure the load in the platform does not exceed the rated capacity.

**NOTE:** *Lift, Swing, and Telescope control switches are spring-loaded and will automatically return to neutral (off) when released.*

#### WARNING

WHEN OPERATING THE BOOM ENSURE THERE ARE NO PERSONNEL AROUND OR UNDER PLATFORM.

##### 5. Lift Control (Main Boom).

The three-position LIFT control switch provides raising and lowering of the main boom when positioned up or down.

**SECTION 3 - USER RESPONSIBILITIES AND MACHINE CONTROL**

1. Power/Emergency Stop Switch
2. Control Station Selector
3. Start Button
4. Capacity Indicator
5. Lift Control (Main Boom)
6. Lift Control (Extend-A-Reach)
7. Telescope Control
8. Swing Control
9. Auxiliary Power Control
10. Circuit Breaker
11. Hourmeter
12. Voltmeter
13. Oil Pressure Gauge
14. Axles Set Indicator
15. Rotate
16. Level

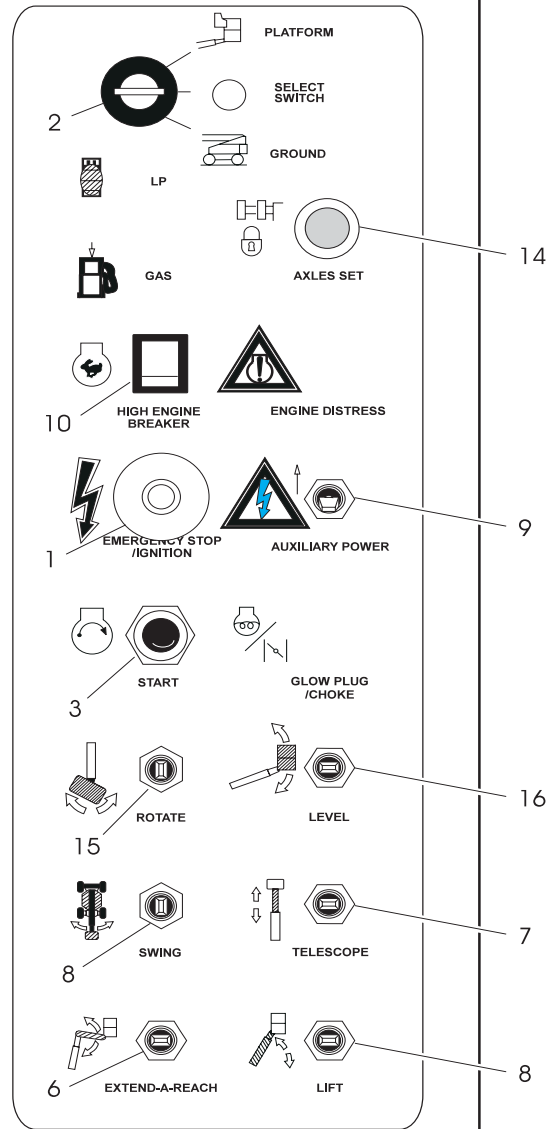
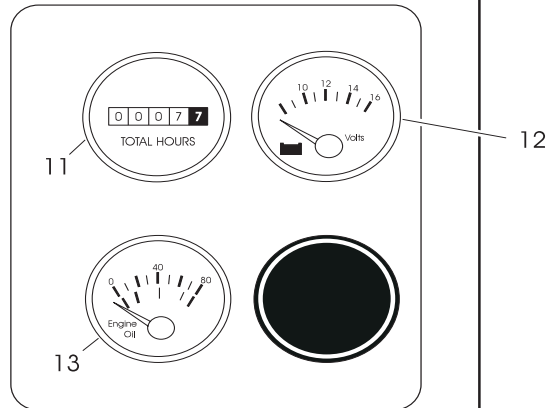
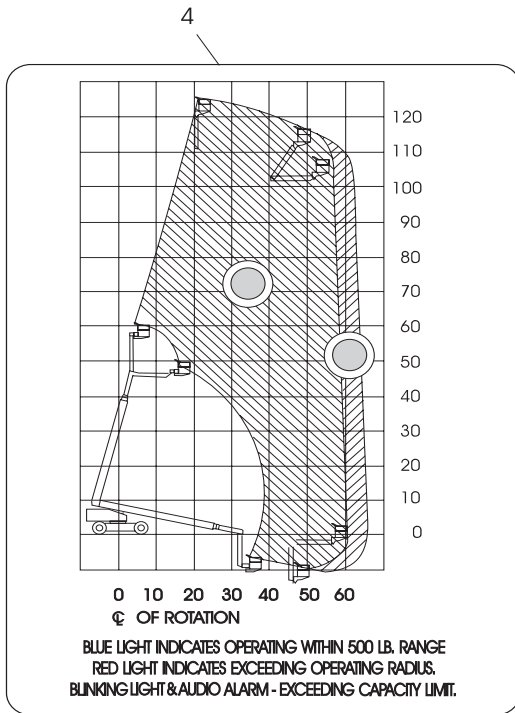

Figure 3-3. Ground Control Station - Prior to May 1994

SECTION 3 - USER RESPONSIBILITIES AND MACHINE CONTROL

1. Power/Emergency Stop Switch
2. Control Station Selector
3. Start Button
4. Capacity Indicator
5. Lift Control (Main Boom)
6. Lift Control (Extend-A-Reach)
7. Telescope Control
8. Swing Control
9. Auxiliary Power Control
10. Circuit Breaker
11. Hourmeter
12. Voltmeter
13. Oil Pressure Gauge
14. Axles Set Indicator
15. Rotate
16. Level

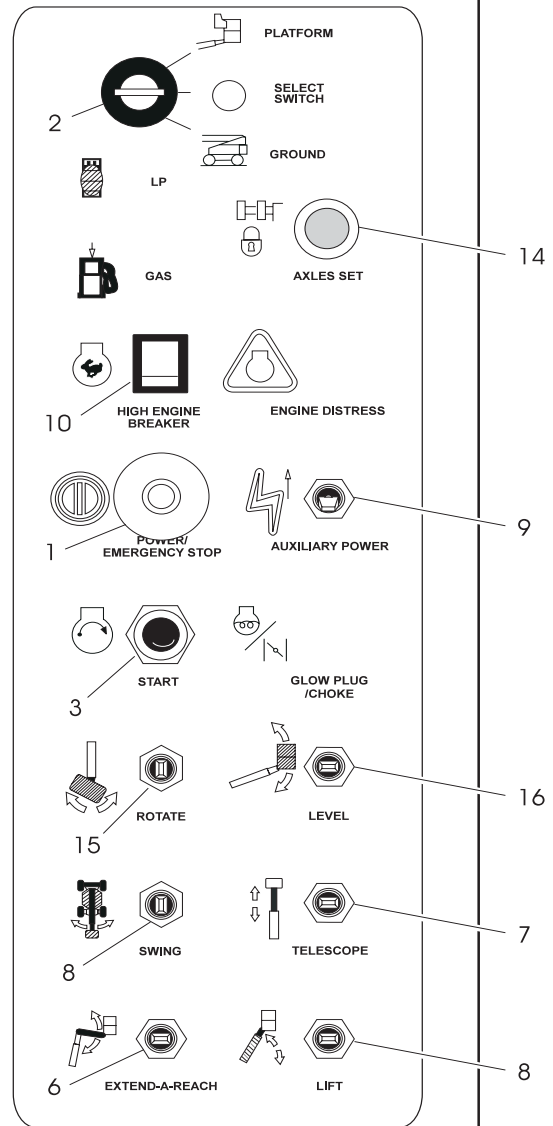
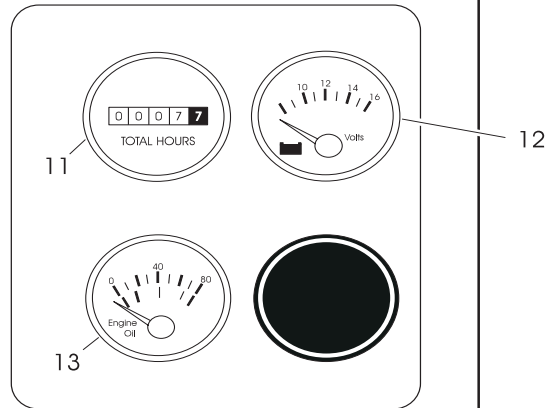
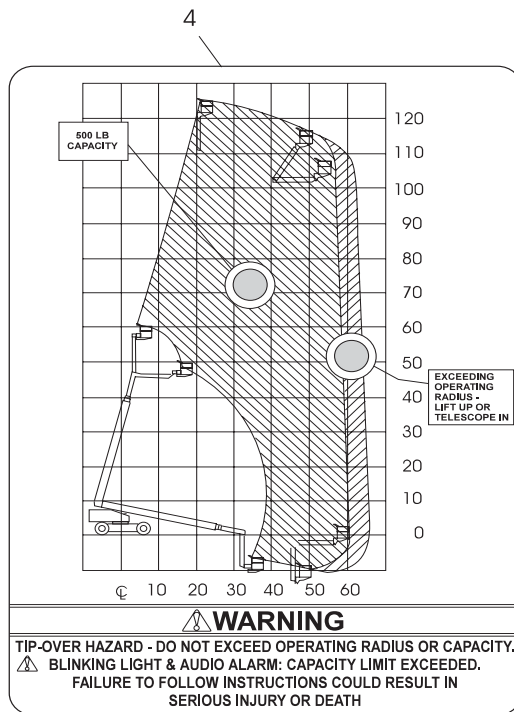

Figure 3-4. Ground Control Station - May 1994 to Present

## SECTION 3 - USER RESPONSIBILITIES AND MACHINE CONTROL

---

### 6. Lift Control (Extend-A-Reach).

A three-position EXTEND-A-REACH lift control switch provides raising/lowering of the Extend-A-Reach when positioned up or down.

### 7. Telescope Control.

The three-position TELESCOPE control switch provides extension and retraction of the boom, when positioned to in or out.

### 8. Swing Control.

The three-position SWING control switch provides 360 degrees continuous turntable rotation when positioned to right or left.

### **⚠ CAUTION**

**WHEN OPERATING ON AUXILIARY POWER, DO NOT OPERATE MORE THEN ONE FUNCTION AT THE SAME TIME. SIMULTANEOUS OPERATION CAN OVERLOAD THE AUXILIARY PUMP MOTOR.**

### 9. Auxiliary Power Control.

A toggle type AUXILIARY POWER control switch energizes the electrically operated auxiliary hydraulic pump, when actuated. The switch must be held in the ON position for the duration of auxiliary pump use.

The auxiliary pump functions to provide sufficient oil flow to operate the basic machine functions should the main hydraulic pumps or engine fail. The auxiliary pump enables the telescope, lift, and swing, functions to be operated.

It should be noted that the functions will operate at a slower than normal rate due to the lower amount of hydraulic flow provided.

### 10. Circuit Breaker.

The 3 amp circuit breaker return control power to the High Engine circuit when depressed.

### 11. Hourmeter.

An hourmeter, installed in the ground control box, registers the amount of time the machine has been in use, with the engine running. The hourmeter registers up to 9,999.9 hours and cannot be reset.

### 12. Voltmeter.

An voltmeter, installed in the ground control box, indicates battery condition (i.e. charging or discharging).

### 13. Oil Pressure Gauge.

An oil pressure gauge, installed in the ground control box, provides an indication of the engine lubricating oil pressure. Normal operating pressure at 2000 rpm is 40 to 60 psi.

### 14. Axles Set Indicator.

The AXLES SET indicator provides a visual indication that the extendable axles are properly set. It consists of a green indicator that lights up when the axles are extended and the retaining pins are properly installed.

### **⚠ WARNING**

**TO AVOID SERIOUS INJURY, DO NOT OPERATE MACHINE IF ANY CONTROL LEVERS OR TOGGLE SWITCHES CONTROLLING PLATFORM MOVEMENT DO NOT RETURN TO THE OFF POSITION WHEN RELEASED.**

### 15. Rotate (If equipped).

The three position platform ROTATE control switch permits rotation of the platform when positioned to left or right.

### 16. Level.

The three position platform LEVEL control switch allows the operator to compensate for any difference in the automatic self leveling system by positioning the control switch to up or down.

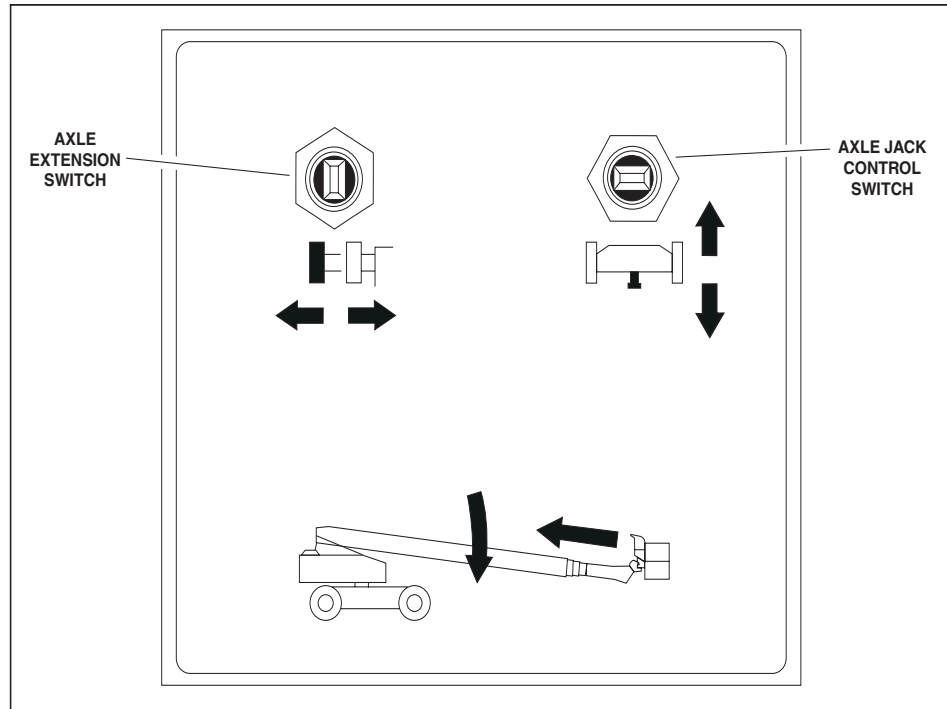

Figure 3-5. Axle Extension/Axle Jacks Control

### Axle Extension/Axle Jacks Control.

**NOTE:** The boom must be fully retracted in the stowed position when axles are being extended. Also, the SELECT SWITCH must be in the GROUND mode, with the engine running.

1. Axle Jack Control Switch.

The axle jack control switch allows the operator to raise the axle so it can be extended before operating the boom. Place the switch in the down position to raise the axle, or to the up position to lower the axle.

2. Axle Extension Switch

The axle extension switch allows the operator to extend the axle after it has been raised by the axle jack. Place the switch to the left to extend the axle or to the right to retract the axle.

### Remote Control Box.

**NOTE:** To operate the remote control box, set the SELECT SWITCH to GROUND and start the engine.

1. Power/Emergency Stop Switch.

Position the Power/Emergency Stop switch to the on position.

2. Steer Switch (Front).

This switch allows the operator to steer the front wheels as desired. The Speed Control switch does not affect the steer function.

3. Drive Switch.

Position the Drive switch to forward or reverse as desired.

4. Speed Control.

Rotate the speed control when driving to increase or decrease drive speed as desired.

5. Steer Switch (Rear).

This switch allows the operator to steer the rear wheels as desired. The Speed Control switch does not affect the steer function.

**SECTION 3 - USER RESPONSIBILITIES AND MACHINE CONTROL**

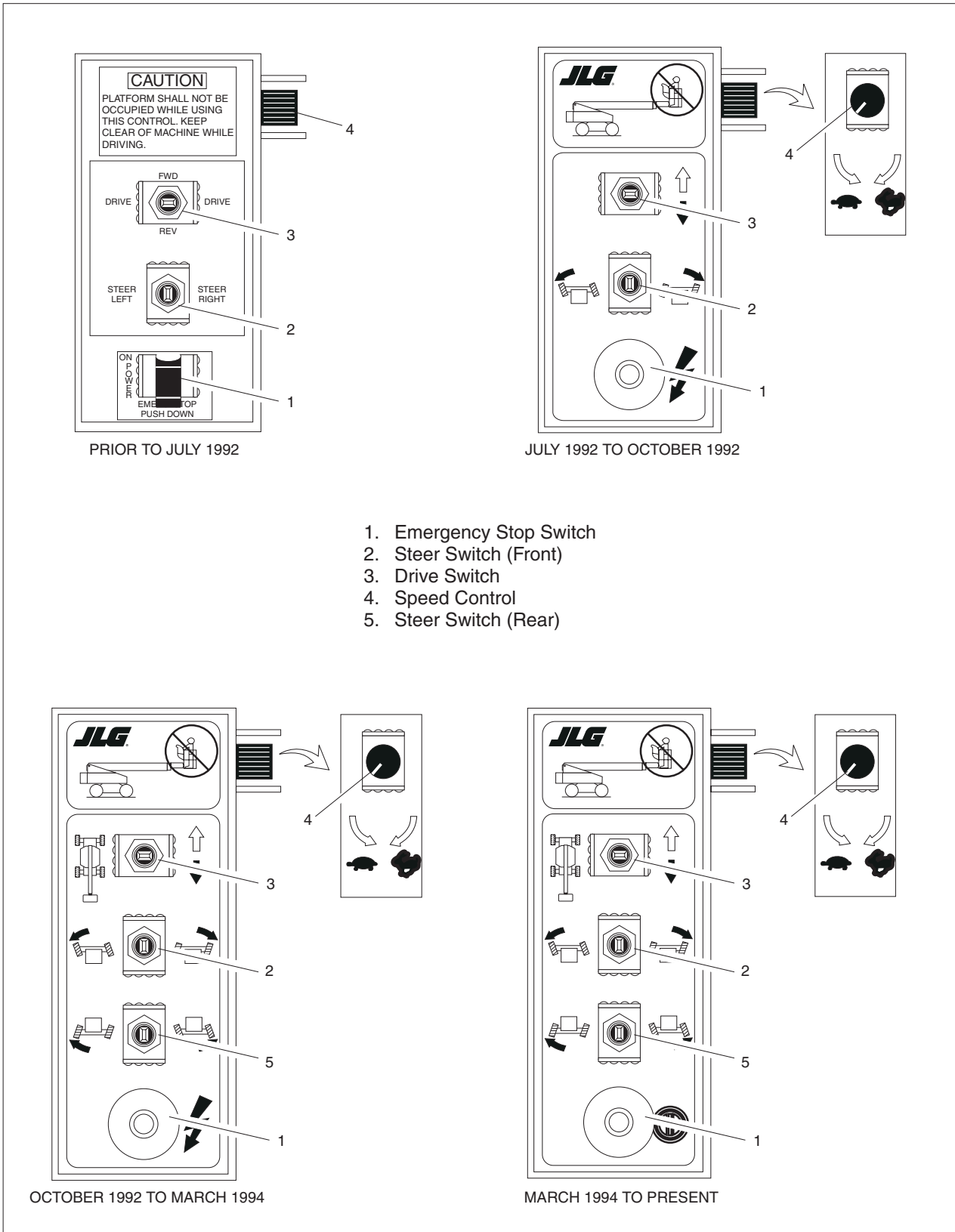

**Figure 3-6. Remote Control Box**



### Platform Station.

**NOTE:** For engine starting, the footswitch must be in the released (up) position. Footswitch must be actuated in order for controls to function.

1. Footswitch.

This feature makes it necessary to depress the footswitch to allow operation of the controls.

#### **WARNING**

TO AVOID SERIOUS INJURY, DO NOT REMOVE, MODIFY OR DISABLE THE FOOTSWITCH BY BLOCKING OR ANY OTHER MEANS.

#### **IMPORTANT**

THE FOOTSWITCH MUST BE ADJUSTED SO FUNCTIONS WILL OPERATE WHEN THE PEDAL IS APPROXIMATELY AT ITS CENTER OF TRAVEL. IF THE SWITCH OPERATES WITHIN LAST 6.35 MM OF TRAVEL, TOP OR BOTTOM, IT SHOULD BE ADJUSTED.

2. Power/Emergency Stop.

An on-off POWER/EMERGENCY STOP switch and a separate START push button on the platform console supply electrical power to the starter solenoid, when the power switch is pulled out to the "on" position and the START button is depressed.

3. Start Button.

The START button is a momentary contact, push-button switch. With the POWER /EMERGENCY STOP switch pulled up and the START button depressed, electrical power is supplied to the start solenoid.

4. Warning Horn.

A push-type HORN switch, when pressed, supplies electrical power to activate the horn.

5. Chassis Out of Level Warning Light.

This red indicator lights to indicate that the chassis is on a slope (over 3 degrees). If illuminated when boom is raised or extended, retract and lower to below horizontal then reposition the machine so that it is level before extending the boom or raising the boom above horizontal.

#### **WARNING**

IF THE CHASSIS OUT OF LEVEL WARNING LIGHT IS ILLUMINATED WHEN THE BOOM IS RAISED OR EXTENDED, RETRACT AND LOWER THE PLATFORM TO BELOW HORIZONTAL THEN REPOSITION THE MACHINE SO IT IS LEVEL BEFORE EXTENDING BOOM OR RAISING THE BOOM ABOVE HORIZONTAL.

**NOTE:** LIFT, SWING, and DRIVE control levers or switches are spring-loaded and will automatically return to the neutral (OFF) position when released.

#### **WARNING**

TO AVOID SERIOUS INJURY, DO NOT OPERATE THE MACHINE IF ANY CONTROL LEVERS OR TOGGLE SWITCHES CONTROLLING THE PLATFORM MOVEMENT DO NOT RETURN TO THE OFF OR NEUTRAL POSITION WHEN RELEASED.

6. Lift.

The LIFT control lever provides raising and lowering of the boom when positioned to up or down and automatically returns to off when released.

7. Telescope.

The TELESCOPE switch provides extension and retraction of the boom when positioned to in or out, and automatically returns to off when released.

8. Swing.

The SWING control lever provides continuous swing when positioned to left or right.

9. Function Speed.

The FUNCTION SPEED switch controls the speed of Extend-A-Reach, Telescope, Basket Rotate, and Basket Level functions. Turning the knob to the left slows the speed and turning the knob to the right increases the speed.rols is dependent upon the position of the STEER/AXLES selector valve.

10. Creep.

The CREEP switch allows the operator to select a lower speed for DRIVE, LIFT, or SWING.

**NOTE:** When the boom is above horizontal, the DRIVE function automatically goes into CREEP speed.

11. Drive/Steer Controller.

The Drive/Steer controller allows the operator to select either forward or reverse when positioning the controller to the desired position. The controller is electrically ramped to allow infinitely variable driving speed between fast and slow. Also, a thumb operated switch on top of the lever controls steer for the rear wheels.

**SECTION 3 - USER RESPONSIBILITIES AND MACHINE CONTROL**

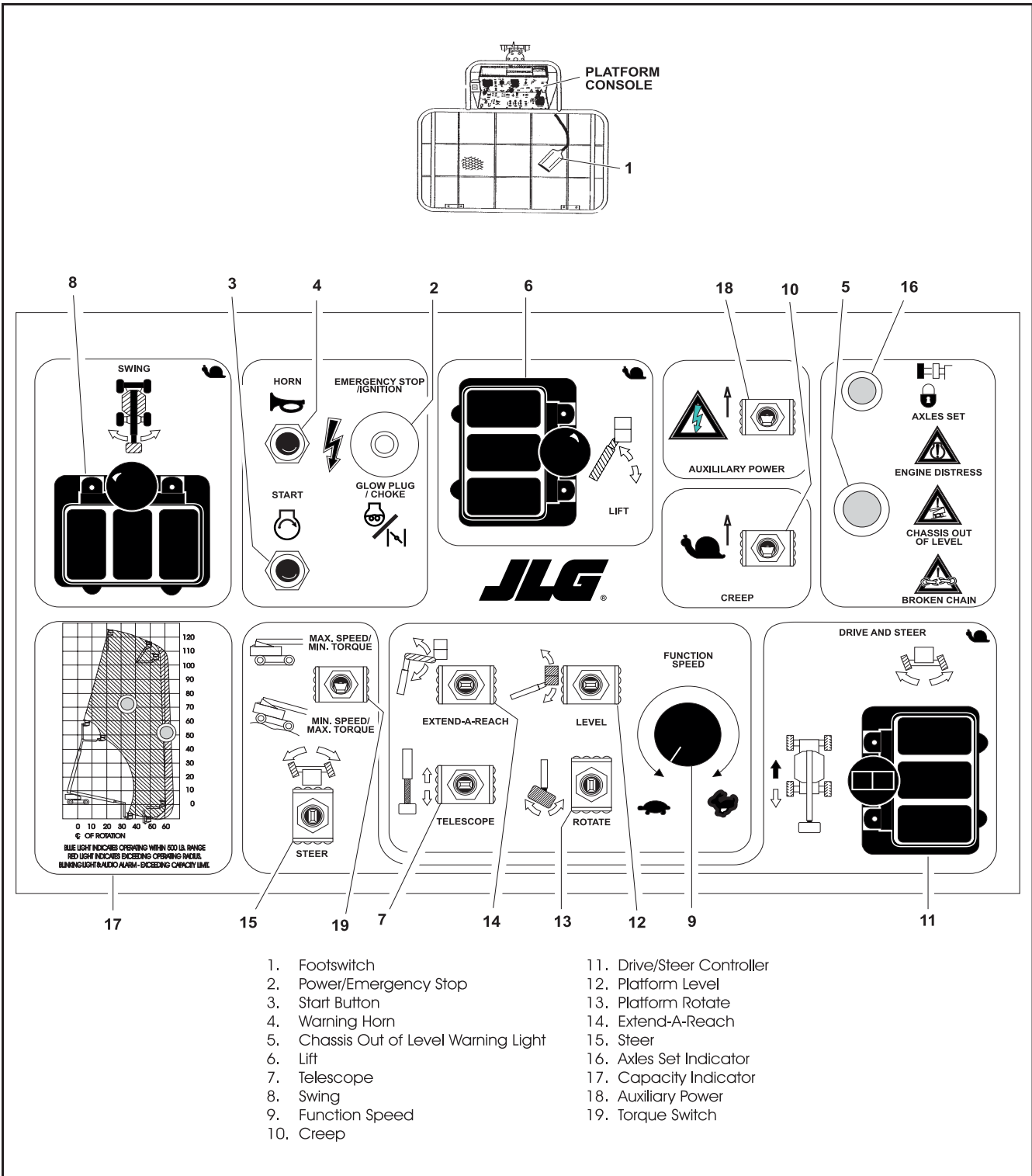

Figure 3-7. Platform Station - Prior to May 1994

SECTION 3 - USER RESPONSIBILITIES AND MACHINE CONTROL

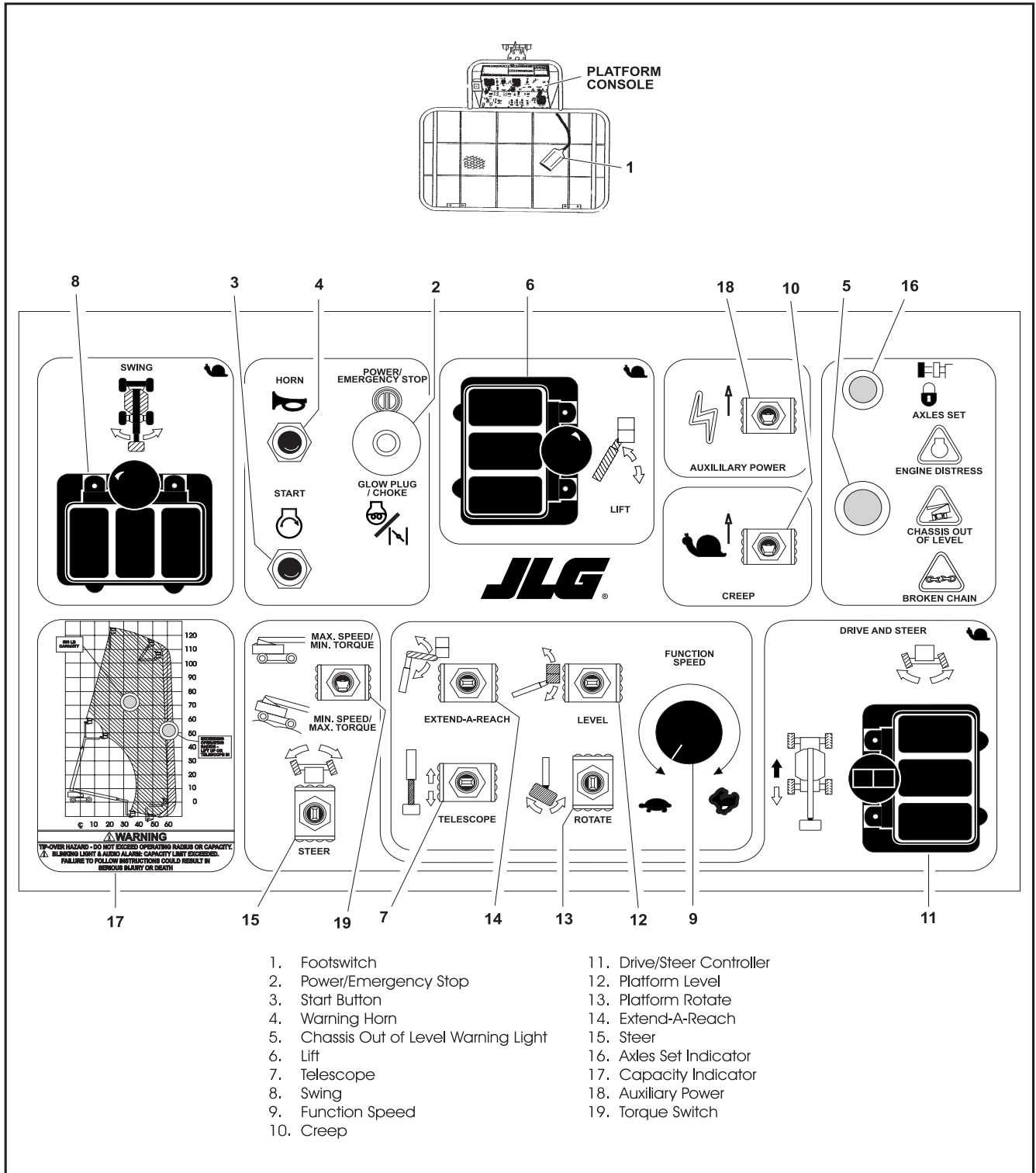

Figure 3-8. Platform Station - May 1994 to Present

## SECTION 3 - USER RESPONSIBILITIES AND MACHINE CONTROL

---

### 12. Platform Level.

The PLATFORM LEVEL control switch allows the operator to compensate for any difference in the automatic self-leveling system by positioning the switch up or down.

### 13. Platform Rotate.

The platform ROTATE control switch allows operator to rotate the basket to the left or right when positioned to the desired direction.

### 14. Extend-A-Reach.

The EXTEND-A-REACH LIFT control switch allows operator to raise or lower the snoot, as required.

### 15. Steer.

Controls operation of the front steer wheels. When the steer switch is positioned right or left, the machine will steer in the corresponding direction.

### 16. Axles Set Indicator (If equipped).

The green AXLES SET indicator lights to inform the operator that the axles are set in position.

**NOTE:** One of the capacity indicator lights should be illuminated at all times during operation. If no capacity lights are on, a bulb is probably burned out. Operation of the machine must be halted until the lights are working properly.

### 17. Capacity Indicator.

The capacity indicator displays to the operator the maximum rated platform capacity and the maximum radius for that capacity using colored lights and a reach diagram. The operator must not exceed the rated capacity or the rated radius for the load (personnel, tools, and supplies) shown on the indicator.

The blue light indicates operating within 500 lb. range. A steady red light indicates you have exceeded the machines operating radius. You must immediately stop and "LIFT UP" or "TELE IN" until the red light goes out. A blinking red light and a buzzer sounding indicates you have exceeded the platform load capacity (personnel, tools, and supplies). You must immediately stop and "LIFT UP" or "TELE IN" until the red light goes out and the buzzer stops. Check to make sure the load in the platform does not exceed the rated capacity.

### 18. Auxiliary Power.

The AUXILIARY POWER control switch energizes the electrically operated hydraulic pump, when actuated. The switch must be held on for duration of auxiliary pump use.

The auxiliary pump functions to provide sufficient oil flow to operate the basic machine system should the main pump or engine fail. The auxiliary pump will operator boom lift, telescope and swing.

It should be noted that the functions will operate at a slower than normal rate because of lower hydraulic flow.

### IMPORTANT

**WHEN OPERATING ON AUXILIARY POWER, DO NOT OPERATE MORE THAN ONE FUNCTION AT THE SAME TIME. SIMULTANEOUS OPERATION CAN OVERLOAD THE AUXILIARY PUMP MOTOR.**

**NOTE:** The main function of the auxiliary power is to lower the platform in the event of primary power failure. Determine the reason for primary power failure and have the problem corrected by a qualified service technician.

**NOTE:** Auxiliary power is primarily intended for platform lowering in the event of primary power failure. However, auxiliary power may be used for platform positioning when operating in close quarters in the following sequence:

- a. Position PLATFORM/GROUND switch to PLATFORM.
- b. Pull the POWER/EMERGENCY STOP switch out to the on position.
- c. Depress and hold footswitch.
- d. Operate appropriate control switch or lever for desired function and hold.
- e. Position AUXILIARY POWER switch on and hold.
- f. Release AUXILIARY POWER switch, selected control switch or lever, and footswitch.
- g. Push the POWER/EMERGENCY STOP switch to the off position.

### 19. Torque Switch.

With the Torque Switch in the upper position, the operator will have maximum drive motor speed and minimum torque. With the switch in the lower position, you have minimum drive motor speed and maximum torque. Use maximum torque for driving on slopes or rough terrain.

### 3.5 PLACARDS AND DECALS

Read and understand all placards and decals. Do not operate any machine on which DANGER, WARNING, CAUTION, or INSTRUCTION PLACARDS OR DECALS ARE MISSING OR ILLEGIBLE. Replace placards and decals if damaged, missing, or illegible.

Decals are made of Lexan Pressure Sensitive Adhesive with a protective film on the front. Remove the damaged decal and thoroughly clean the surface before installing a new decal. Simply peel off, press on to the surface.

**NOTE:** *Placards and Decals can be ordered by using the part numbers located by each placard or decal. (See Figure 3-8. Placards, Decals, and Part Numbers Location.*

SECTION 3 - USER RESPONSIBILITIES AND MACHINE CONTROL

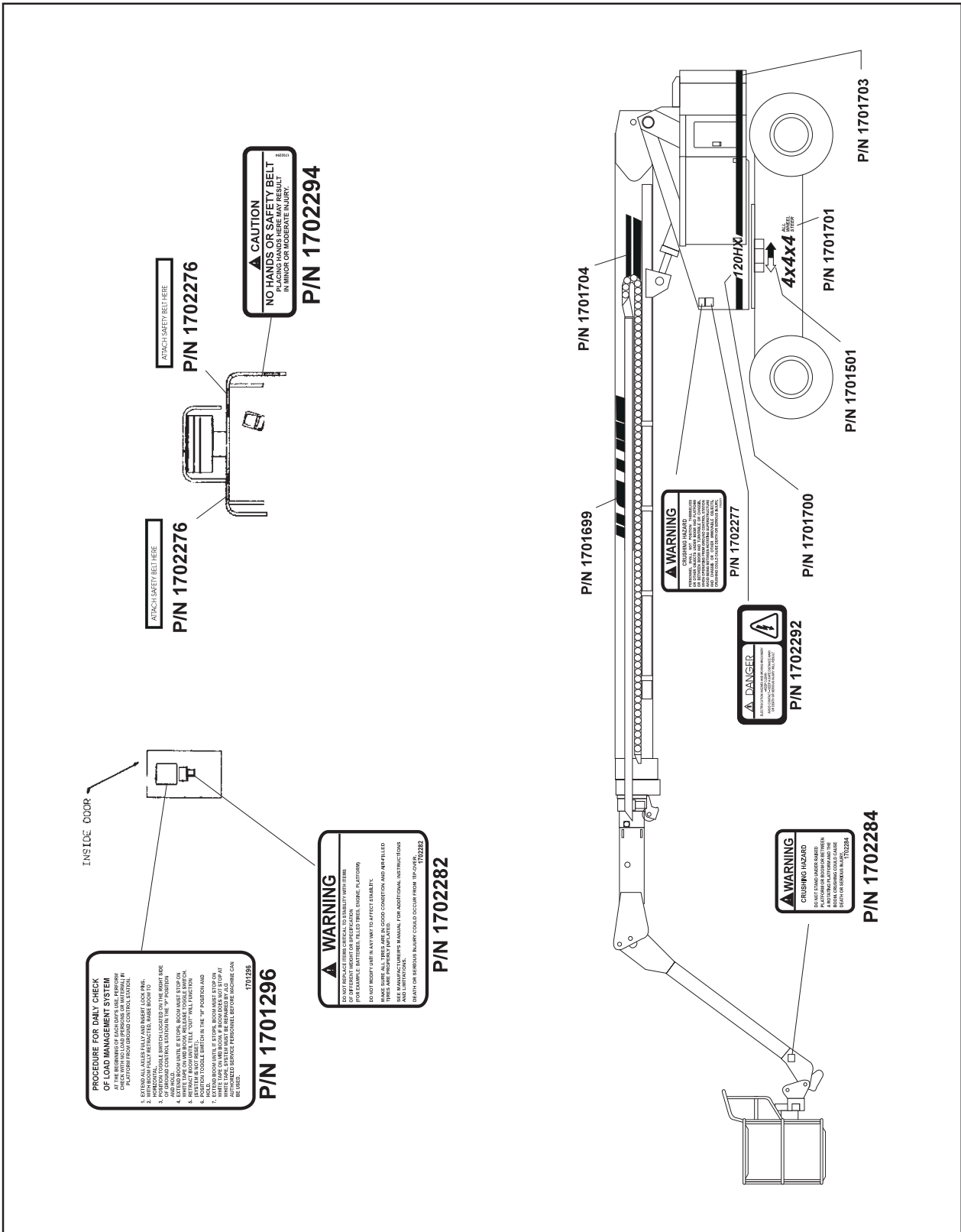

Figure 3-9. Caution Decal Location - Sheet 1



**PROCEDURE FOR DAILY CHECK OF LOAD MANAGEMENT SYSTEM**

AT THE BEGINNING OF EACH DAY'S USE, PERFORM CHECK WITH NO LOAD (PERSONS OR MATERIAL) IN PLATFORM FROM GROUND CONTROL STATION.

1. EXTEND ALL AXLES FULLY AND INSERT LOCK PINS.
2. WITH BOOM FULLY RETRACTED, RAISE BOOM TO HORIZONTAL.
3. POSITION TOGGLE SWITCH LOCATED ON THE RIGHT SIDE OF GROUND CONTROL STATION IN THE "P" POSITION AND HOLD.
4. EXTEND BOOM UNTIL IT STOPS. BOOM MUST STOP ON WHITE TAPE ON MID BOOM. RELEASE TOGGLE SWITCH.
5. RETRACT BOOM UNTIL TELE "OUT" WILL FUNCTION (SYSTEM IS NOT RESET).
6. POSITION TOGGLE SWITCH IN THE "M" POSITION AND HOLD.
7. EXTEND BOOM UNTIL IT STOPS. BOOM MUST STOP ON WHITE TAPE ON MID BOOM. IF BOOM DOES NOT STOP AT WHITE TAPE, SYSTEM MUST BE REPAIRED BY JLG AUTHORIZED SERVICE PERSONNEL BEFORE MACHINE CAN BE USED.

1701296

P/N 1701296-

**⚠ WARNING**

**CRUSHING HAZARD**

PERSONNEL SHALL NOT POSITION THEMSELVES OR OTHER OBJECTS UNDER BOOM AND PLATFORM OR BETWEEN BOOM AND TURNTABLE OR CHASSIS. WHEN OPERATING FROM GROUND CONTROL STATION AVOID BEING BETWEEN ROTATING SUPERSTRUCTURE AND CHASSIS OR OTHER IMMOVABLE OBJECTS. CRUSHING COULD CAUSE DEATH OR SERIOUS INJURY.

1702277

P/N 1702277-

**⚠ WARNING**

DO NOT REPLACE ITEMS CRITICAL TO STABILITY WITH ITEMS OF DIFFERENT WEIGHT OR SPECIFICATION (FOR EXAMPLE: BATTERIES, FILLED TIRES, ENGINE, PLATFORM)

DO NOT MODIFY UNIT IN ANY WAY TO AFFECT STABILITY.

MAKE SURE ALL TIRES ARE IN GOOD CONDITION AND AIR-FILLED TIRES ARE PROPERLY INFLATED.

SEE MANUFACTURER'S MANUAL FOR ADDITIONAL INSTRUCTIONS AND LIMITATIONS.

DEATH OR SERIOUS INJURY COULD OCCUR FROM TIP-OVER.

1702282

P/N 1702282-

**⚠ IMPORTANT**

first delivery ←	OSHA and ANSI require frequent and annual inspection by properly trained personnel.	5 years →
← 1 year	Use JLG approved manuals, parts and procedures. Contact JLG regarding structural repairs.	6 years →
← 2 years	Stamp frame with MONTH/DAY/YEAR next to arrow after each inspection. Retain records for OSHA; Copy JLG.	7 years →
← 3 years	Notify JLG of changes of owner, user or location, or if inspection is overdue.	8 years →
← 4 years	Replace if defaced	9 years →
DOM		10 years →

1702153 C

P/N 1702153-C

**⚠ WARNING**

**CRUSHING HAZARD**

DO NOT STAND UNDER RAISED PLATFORM OR BOOM OR BETWEEN A ROTATING PLATFORM AND THE BOOM. CRUSHING COULD CAUSE DEATH OR SERIOUS INJURY.

1702284

P/N 1702284-





**P/N 1702292-**



**P/N 1702294-B**



**P/N 1702299-A**

**SECTION 3 - USER RESPONSIBILITIES AND MACHINE CONTROL**







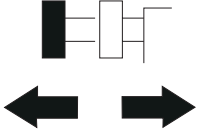

FUNCTION	SYMBOL	FUNCTION	SYMBOL
AUXILIARY POWER		FUEL	
AXLE EXTEND		L.P. - GAS	
AXLE JACK		PLATFORM CONTROL	
AXLE SET		GROUND CONTROL	
CHASSIS OUT OF LEVEL		HIGH ENGINE BREAKER	
CREEP		HORN	
SLOW		EXTEND-A-REACH	
FAST		LIFT	
DRIVE		TELESCOPE	

Figure 3-11. Control Panel Symbols - Sheet 1 of 2

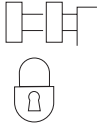
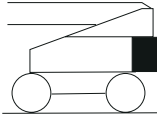
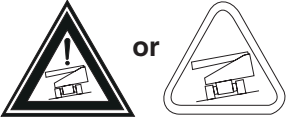



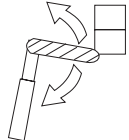

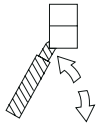
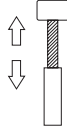

FUNCTION	SYMBOL	FUNCTION	SYMBOL
MAXIMUM SPEED MINIMUM TORQUE		SWING	
MINIMUM SPEED MAXIMUM TORQUE		PLATFORM LEVEL	
OFF		PLATFORM ROTATE	
START		STEER	
IGNITION/ EMERGENCY STOP		BROKEN CHAIN	

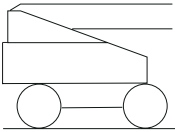
Figure 3-12. Control Panel Symbols - Sheet 2 of 2

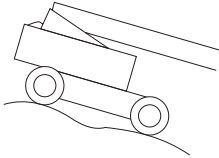
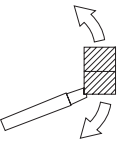
**This page left blank intentionally.**

---

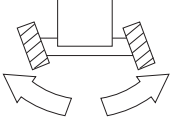
## SECTION 4. MACHINE OPERATION

---

### 4.1 DESCRIPTION

This machine is a self-propelled aerial work platform on the end of an elevating, telescoping and rotating boom. The JLG Lift's intended purpose is to position personnel with their tools and supplies at positions above ground level. The machine can be used to reach work areas located above and over machinery or equipment.

The JLG Lift has a primary operator Control Station in the platform. From this Control Station, the operator can drive and steer the machine in both forward and reverse directions. The operator can raise, lower, extend or retract the boom; swing the boom to the left or right; and when equipped with a platform rotator, can rotate the platform around the boom end. Standard boom swing is 360° continuous left and right of the stowed position. The machine has a Ground Control Station which will override the Platform Control Station. Ground Controls operate boom lift, telescope and swing and are to be used only in an emergency to lower the platform to the ground should the operator in the platform be unable to do so.

Instruction and hazard warnings are posted adjacent to both operator control stations and at other places on the machine. It is extremely important that operators know what instructions and warnings are placed on the machine, and review these periodically so that they are fresh in their minds. Vibrations emitted by these machines are not hazardous to an operator in the work platform.

The JLG Lift is designed to provide efficient and safe operation when maintained and operated in accordance with warnings on the machine, in the Operators and Safety Manual, and all jobsite and government rules and regulations. As with any type of machinery, the operator is very important to efficient and safe operation. Owner/user/operator/lessors/lessees must be familiar with Sections 6, 7, 8, 9, and 10 of ANSI A92.5-1992. These sections contain the responsibilities of the owner, users, operators, lessors and lessees concerning safety, training, inspection, maintenance, application and operation. It is absolutely necessary that the JLG Lift be regularly maintained in accordance with this manual and the machine Service and Maintenance manual, and that any evidence of lack of maintenance, malfunction, excessive wear, damage or modification to the machine be reported immediately to the machine owner or the jobsite supervisor or safety manager and that the machine be taken out of service until all discrepancies are corrected.

The JLG Lift is not intended to be used to lift material other than supplies which personnel in the platform require to do their job. Supplies or tools which extend outside the platform are prohibited. It must not be used as a forklift, crane, support for overhead structure, or to push or pull another object.

The machine is equipped with an auxiliary battery operated power unit which will provide hydraulic power in the event of a primary engine power loss. Auxiliary power can be controlled from either the Platform Control Station or the Ground Control Station. Follow the instructions placed at the control stations.

The JLG Lift is hydraulically powered using hydraulic motors and cylinders for various machine motions. The hydraulic components are controlled by electrically activated hydraulic valves using switches and control levers. The speeds of functions controlled by control levers are variable from zero to maximum speed depending upon the position of the control lever. Functions controlled by toggle switches are either on or off and higher or lower speed is possible when the Function Speed control switch is used in conjunction with the function toggle switch. A foot operated switch in the platform must be depressed before any controls will function and provides a means of emergency stop when the operator's foot is removed from the footswitch.

The JLG Lift is a four-wheel drive, four-wheel steer machine with drive power being supplied by a hydraulic motor for each drive wheel. Each drive wheel is supplied with a hydraulically released, spring-applied brake. The swing drive is also equipped with such a brake. These brakes are automatically applied any time the Drive or Swing Control lever are returned to the neutral position.

The maximum rated capacity of the JLG Lift is 500lbs. (230 kg). This means that with a platform load of 500lbs. (230 kg) or less, the platform may be positioned anywhere in the Blue (light) Area of the reach diagram.

---

### 4.2 GENERAL

This section provides the necessary information needed to operate the machine. Included in this section are the procedures for starting, stopping, traveling, steering, parking, platform loading and transporting. It is important that the user read and understand the proper procedures before operating the machine.

### 4.3 ENGINE OPERATION

**NOTE:** Initial starting should always be performed from the Ground Control station.

#### Starting Procedure

---

1. Check engine oil. If necessary, add oil in accordance with the Engine Manufacturer's manual.
2. Check fuel level. Add fuel if necessary.
3. Check that air cleaner components are in place and securely fastened.

#### **⚠ CAUTION**

IF ENGINE FAILS TO START PROMPTLY, DO NOT CRANK FOR AN EXTENDED PERIOD. SHOULD ENGINE FAIL TO START ONCE AGAIN, ALLOW STARTER TO "COOL OFF" FOR 2-3 MINUTES. IF ENGINE FAILS AFTER SEVERAL ATTEMPTS, REFER TO ENGINE MAINTENANCE MANUAL.

4. Position the SELECT SWITCH to ground. Position the POWER/EMERGENCY STOP switch to ON, then push the START switch until engine starts.

#### **⚠ CAUTION**

ALLOW ENGINE TO WARM-UP FOR A FEW MINUTES AT LOW SPEED BEFORE APPLYING ANY LOAD.

5. After engine has had sufficient time to warm up, shut engine off.
6. Position SELECT SWITCH to PLATFORM.
7. From Platform position IGNITION switch to ON, then push the START switch to the forward position until engine starts.

**NOTE:** The footswitch must be in released (up) position before starter will operate. If starter operates with footswitch in the depressed position, DO NOT OPERATE THE MACHINE.

#### Shutdown Procedure

---

#### **⚠ CAUTION**

IF AN ENGINE MALFUNCTION NECESSITATES UNSCHEDULED SHUTDOWN, DETERMINE AND CORRECT CAUSE BEFORE RESUMING ANY OPERATION.

1. Remove all load and allow engine to operate at low speed setting for 3-5 minutes; this allows for further reduction of internal engine temperature.
2. Position POWER/EMERGENCY STOP switch to OFF.

3. Turn the SELECT SWITCH to OFF position.

**NOTE:** Refer to Engine Manufacturer's manual for detailed information.

### 4.4 TRAVELING (DRIVING/STEERING)

#### **⚠ WARNING**

DO NOT DRIVE WITH BOOM EXTENDED OR ABOVE HORIZONTAL EXCEPT ON A SMOOTH, FIRM AND LEVEL SURFACE.

TO AVOID LOSS OF TRAVEL CONTROL OR UPSET ON GRADES AND SIDE SLOPES, DO NOT DRIVE MACHINE ON GRADES OR SIDE SLOPES EXCEEDING THOSE SPECIFIED ON SERIAL NUMBER PLATE.

ASSURE THAT TURNTABLE LOCK IS ENGAGED BEFORE BEGINNING ANY EXTENDED TRAVELING. AVOID ANY TERRAIN FEATURES WHICH COULD CAUSE THE MACHINE TO UPSET.

USE EXTREME CAUTION WHEN DRIVING IN REVERSE AT ALL TIMES WHEN DRIVING WITH PLATFORM ELEVATED AND ESPECIALLY WHEN DRIVING WITH ANY PART OF MACHINE WITHIN 6 FEET (2 METERS) OF AN OBSTRUCTION. DO NOT USE DRIVE TO MANEUVER PLATFORM CLOSE TO AN OBSTRUCTION....USE ONE OF THE BOOM FUNCTIONS.

BEFORE DRIVING, MAKE SURE BOOM IS POSITIONED OVER REAR AXLE. IF BOOM IS OVER FRONT AXLE (STEER WHEELS), STEER AND DRIVE CONTROLS WILL MOVE IN OPPOSITE DIRECTIONS TO MACHINE CONTROLS.

#### Traveling Forward or Reverse

---

1. With engine running, depress footswitch and position DRIVE/STEER control forward and hold for the duration of forward travel desired.
2. Depress footswitch and pull the DRIVE/ STEER control back to reverse and hold for duration of reverse travel desired.

**NOTE:** When boom is above horizontal, the DRIVE function will be in CREEP mode.

**NOTE:** When machine exceeds 5 degree slope, DRIVE functions will be cut out, and SWING and LIFT are in CREEP mode if boom is above horizontal.

3. Position the STEER thumb rocker to the right for traveling right and left for traveling left.
4. To obtain maximum travel speed, make sure the boom is positioned below horizontal and position the DRIVE controller to fast.

## 4.5 AXLES

**NOTE:** To extend or retract jacks or to extend or retract the axles, the boom must be below horizontal and not extended more than 10 feet (3 meters). The machine must also be on a flat, level surface.

### To Extend the Axles

1. Remove the pins from the front steer cylinder and tie rod. Be sure the SELECT SWITCH is set to GROUND.
2. Machines after S/N 47227 have spindle stop pins to keep the spindles centered while extending the axle. Place the stop pin in the hole closest to the spindle as shown.



3. From the controls at the front axle, with the engine running, push the axle jack control switch down to raise the axle.
4. When the tires are off the ground, push the axle extend switch to the left to extend the axle. When the axle is fully extended, return the pins to the front steer cylinder and tie rod. On machines after S/N 47227, return the spindle stop pin to the steering position.

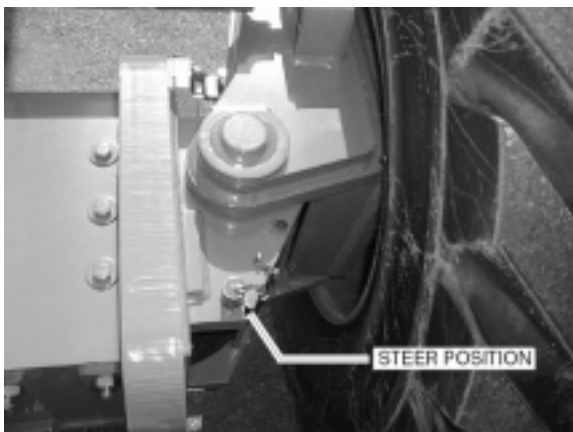

5. Repeat steps 1 thru 3 for the for the rear axle. The machine is now ready for boom operations.

### To Retract the Axles

1. Remove the pins from the front steer cylinder and tie rod. Be sure the SELECT SWITCH is set to GROUND. On machines after S/N 47227, place the spindle stop pin in the Axle Extend/Retract position.



2. From the controls at the front axle, with the engine running, push the axle jack control switch down to raise the axle.
3. Swing the steer cylinder clear of the axle tube before retracting the axle.
4. When the tires are off the ground, push the axle extend switch to the right to retract the axle. When the axle is fully retracted, align the steer cylinder with the mounting bracket and return the pins to the front steer cylinder and tie rod. On machines after S/N 47227, return the spindle stop pin to the steering position.

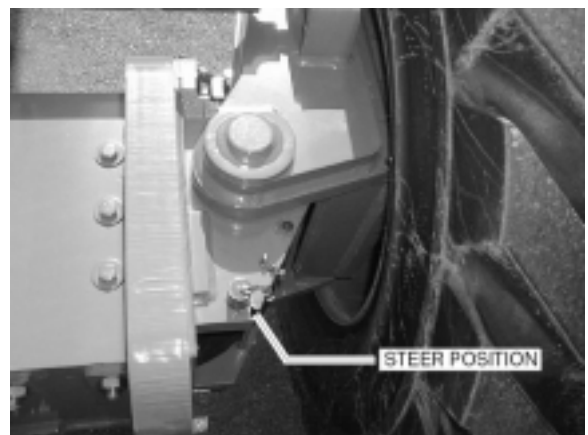

5. Repeat steps 1 thru 4 for the for the rear axle.

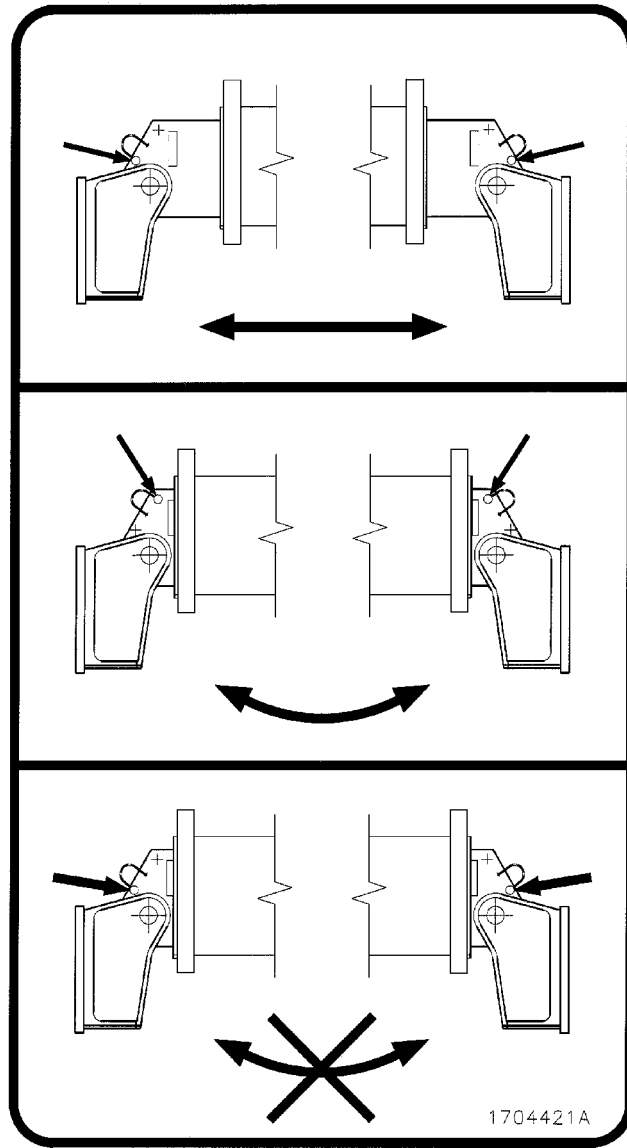

Figure 4-1. Spindle Stop Pin Usage



---

## **4.6 PARKING AND STOWING**

Park and stow machine as follows:

1. Park machine in travel position; boom lowered over rear, all access panels and doors closed and secured, ignition off, turntable locked.
2. Check that brakes hold machine in position.
3. Chock wheels front and rear.
4. Turn off SELECT SWITCH and remove key.

---

## **4.7 PLATFORM**

---

### **Loading From Ground Level**

1. Position chassis on a smooth, firm and level surface.
2. If total load (personnel, tools and supplies) is less than rated capacity, distribute load uniformly on platform floor and proceed to work position.

---

### **Loading From Positions Above Ground Level**

Before loading weight to platform above ground level:

1. Determine what the total rated capacity weight will be after additional weight is loaded (personnel, tools and supplies).
2. If total weight in platform will be less than rated capacity, proceed with adding weight.

---

### **Platform Level Adjustment**

1. Leveling UP. Depress footswitch to raise platform, position PLATFORM LEVEL control switch UP and hold until platform is level.
2. Leveling DOWN. Depress footswitch to lower platform, position PLATFORM LEVEL control switch to DOWN and hold until platform is level.

---

### **Platform Rotation**

1. Depress footswitch to rotate platform to the left, PLATFORM ROTATE control is positioned to the LEFT and held until desired position is reached.
2. Depress footswitch to rotate platform to the right, PLATFORM ROTATE control is positioned to the RIGHT and held until desired position is reached.

### 4.8 BOOM

#### **⚠ WARNING**

A RED TILT ALARM WARNING LIGHT, LOCATED ON THE CONTROL CONSOLE, LIGHTS WHEN THE CHASSIS IS ON A SEVERE SLOPE (5 DEGREES OR GREATER). DO NOT SWING, EXTEND OR RAISE BOOM ABOVE HORIZONTAL WHEN LIT.

DO NOT DEPEND ON TILT ALARM AS A LEVEL INDICATOR FOR THE CHASSIS. TILT ALARM INDICATES CHASSIS IS ON A SEVERE SLOPE (5 DEGREES OR GREATER). CHASSIS MUST BE LEVEL BEFORE SWINGING, EXTENDING OR RAISING BOOM ABOVE HORIZONTAL.

TO AVOID UPSET, IF RED TILT ALARM WARNING LIGHT LIGHTS WHEN MAIN BOOM IS EXTENDED OR RAISED ABOVE HORIZONTAL, RETRACT AND LOWER PLATFORM TO NEAR GROUND LEVEL. THEN REPOSITION MACHINE SO THAT CHASSIS IS LEVEL BEFORE EXTENDING OR RAISING BOOM.

TRAVELING WITH BOOM RETRACTED AND BELOW HORIZONTAL IS PERMITTED ON GRADES SPECIFIED ON SERIAL NUMBER PLATE.

TO AVOID SERIOUS INJURY, DO NOT OPERATE MACHINERY IF ANY CONTROL LEVERS OR TOGGLE SWITCHES CONTROLLING PLATFORM MOVEMENT DO NOT RETURN TO THE OFF OR NEUTRAL POSITION WHEN RELEASED.

TO AVOID A COLLISION AND INJURY IF PLATFORM DOES NOT STOP WHEN A CONTROL SWITCH OR LEVER IS RELEASED, REMOVE FOOT FROM FOOTSWITCH OR USE EMERGENCY STOP TO STOP THE MACHINE.

### Swinging the Boom

#### **⚠ IMPORTANT**

ASSURE THAT TURNTABLE LOCK IS DISENGAGED BEFORE STARTING ANY SWING OPERATION.

Depress footswitch to swing boom, position SWING control switch or controller to RIGHT or LEFT for direction desired.

**NOTE:** *When boom functions are being operated there is an interlock that prevents the use of DRIVE and STEER functions.*

### Raising and Lowering the Main Boom

To raise and lower Boom, position LIFT control switch or controller to UP OR DOWN and hold until desired height is reached.

### Telescoping the Main Boom

To extend or retract Boom, position TELESCOPE control switch to IN or OUT and hold until platform reaches desired position.

### 4.9 SHUT DOWN AND PARK

1. Drive machine to a protected area.
2. Position FUNCTION SPEED control on Platform Control Console to low.
3. Assure main boom is fully retracted and lowered over rear (Drive) axle; all access panels and doors closed and secured.

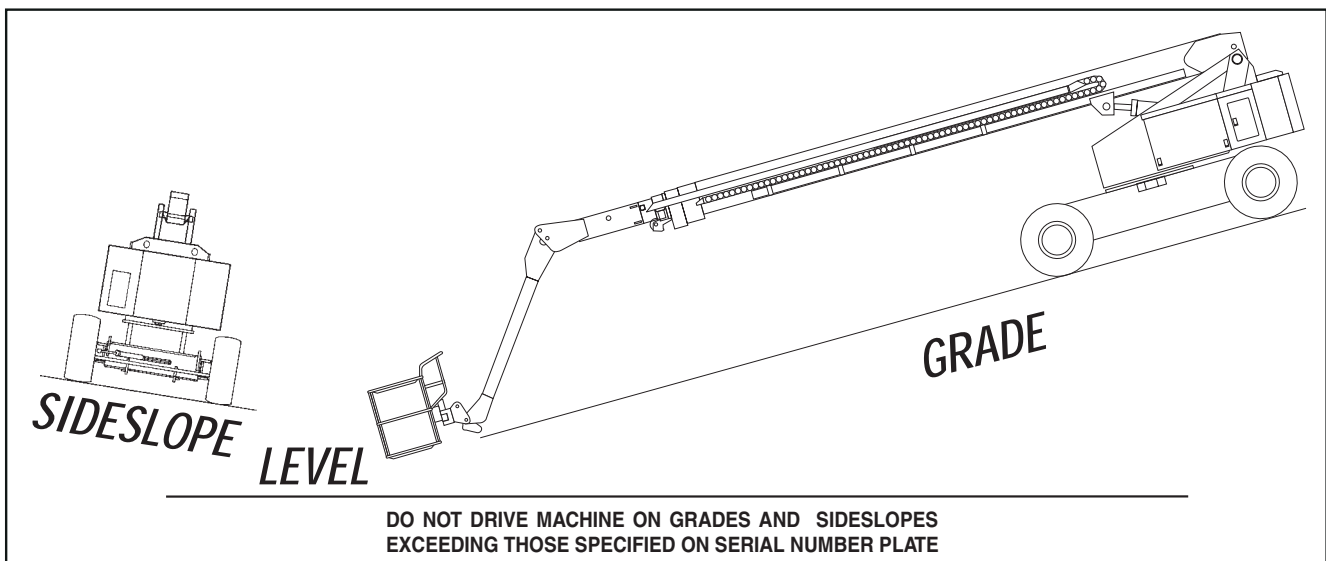

Figure 4-2. Grade and Side Slope

4. Remove all load and allow engine to operate 3-5 minutes at LOW setting to permit reduction of engine internal temperatures.
5. At Ground Controls, turn MASTER SWITCH to (center) OFF. Position, the IGNITION switch (down) to OFF.
6. Cover the Platform Control Console to protect instruction placards, warning decals and operating controls from hostile environment.

engaged and machine securely tied down to truck or trailer deck. Four tie down eyes are provided in the frame slab, one at each corner of the machine.

If it becomes necessary to lift the machine using an overhead or mobile crane, it is very important that the lifting devices are attached only to the designated lifting eyes, and that the turntable lock pin is engaged. See Figure 4-3, Lifting Chart.

**NOTE:** *Lifting eyes are provided at the front and rear in the frame slab. Each of the four chains or slings used for lifting machine must be adjusted individually so machine remains level when elevated.*

---

#### **4.10 TIE DOWN AND LIFTING**

When transporting machine, boom and extend-a-reach must be in the stowed mode with turntable lock pin

**Note**

When transporting the machine over rough terrain or long distances, the boom needs to be chocked and strapped whenever the base boom is unable to rest on its pad. This prevents the boom from "bouncing" up and down preventing possible damage while transporting.

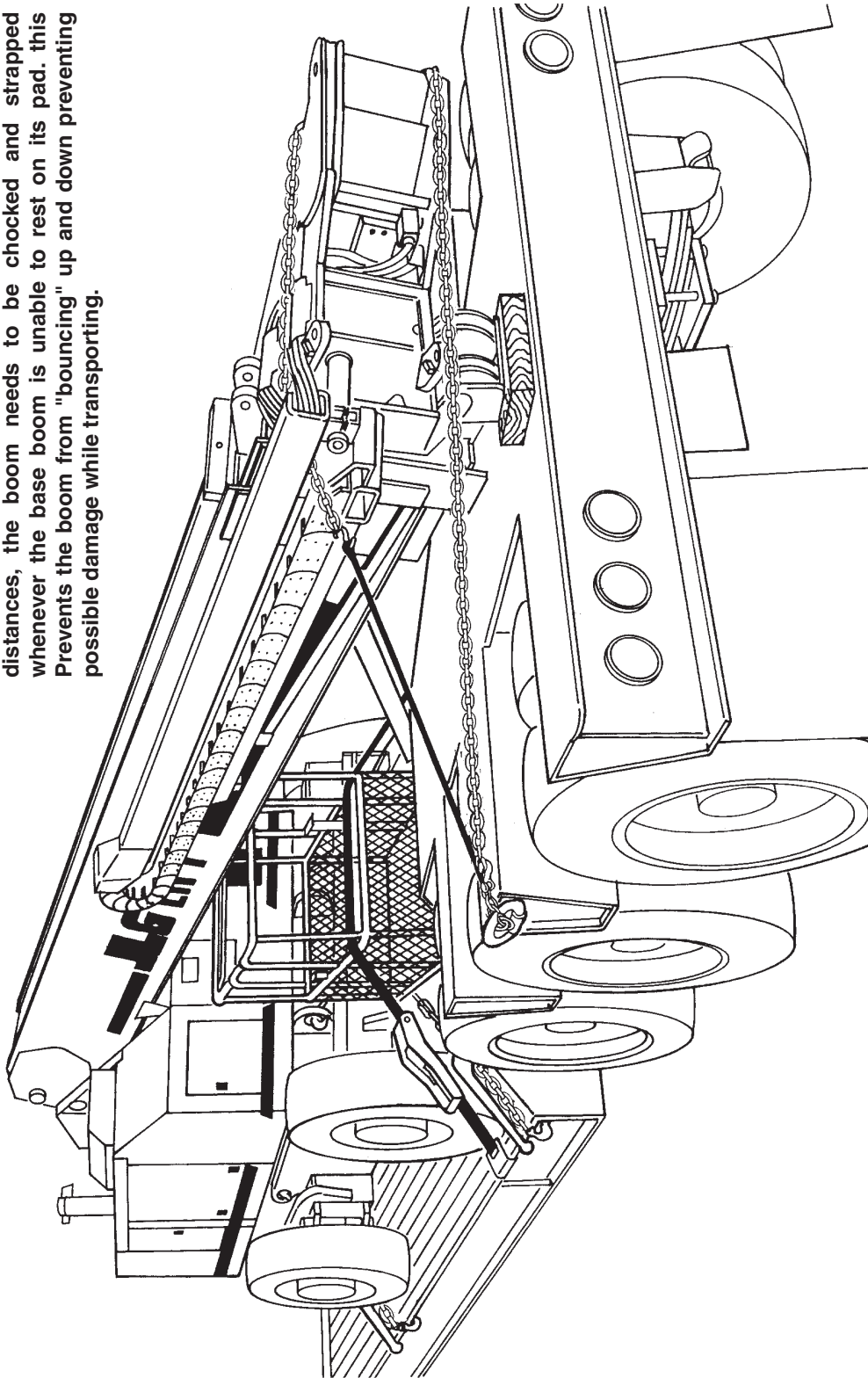

Figure 4-3. Machine Tie Down - Sheet 1

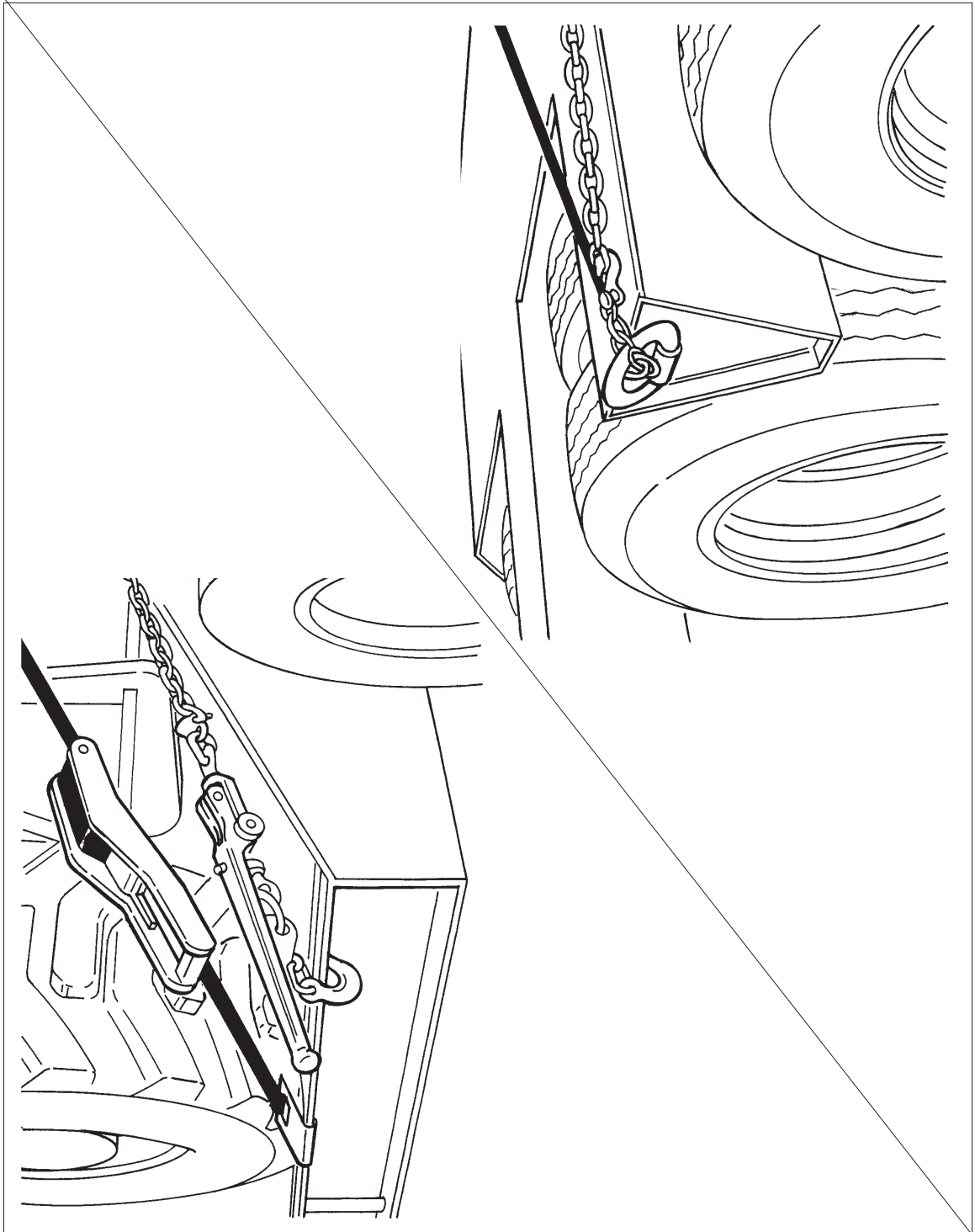

Figure 4-4. Machine Tie Down - Sheet 2

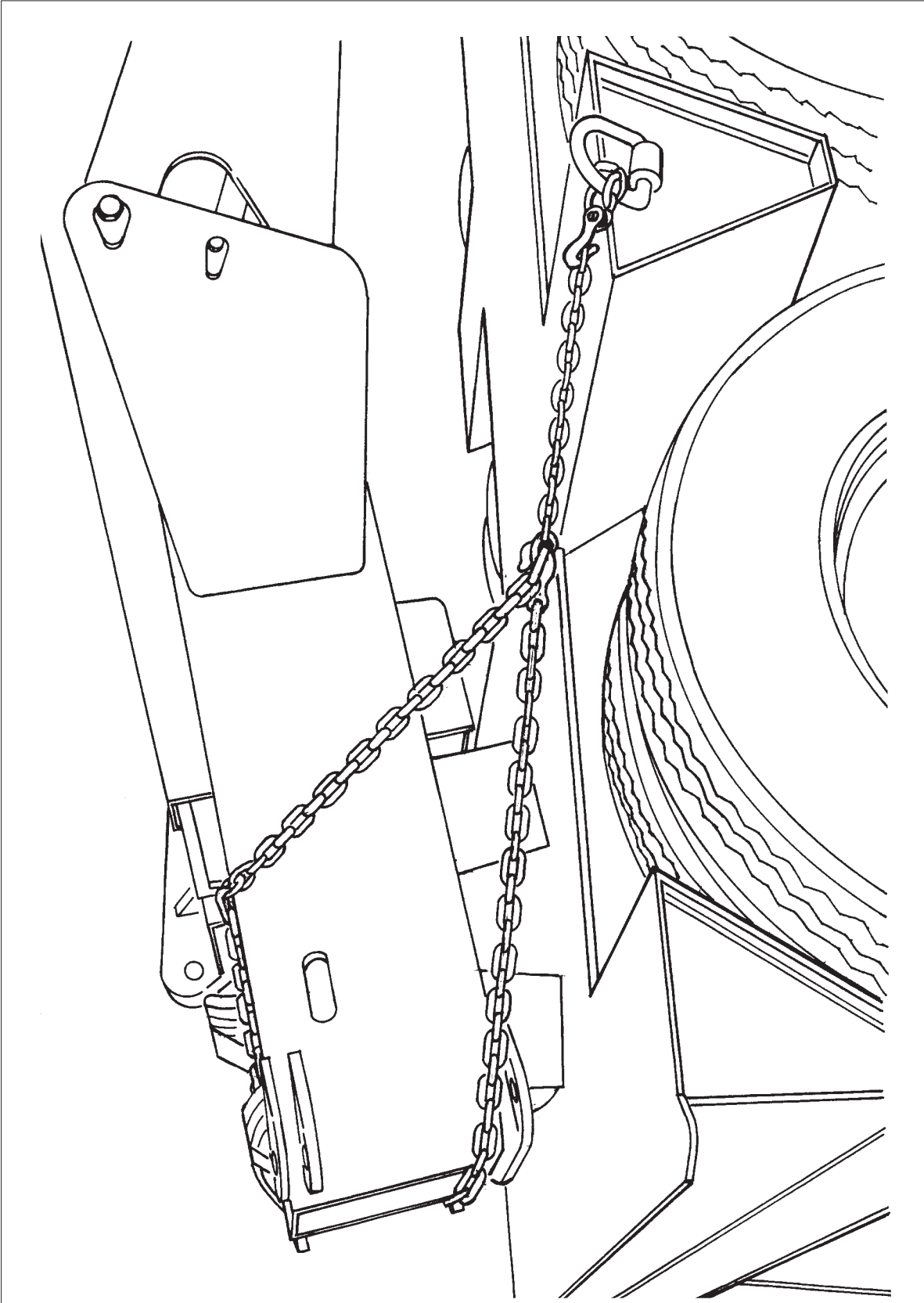

Figure 4-5. Machine Tie Down - Sheet 3

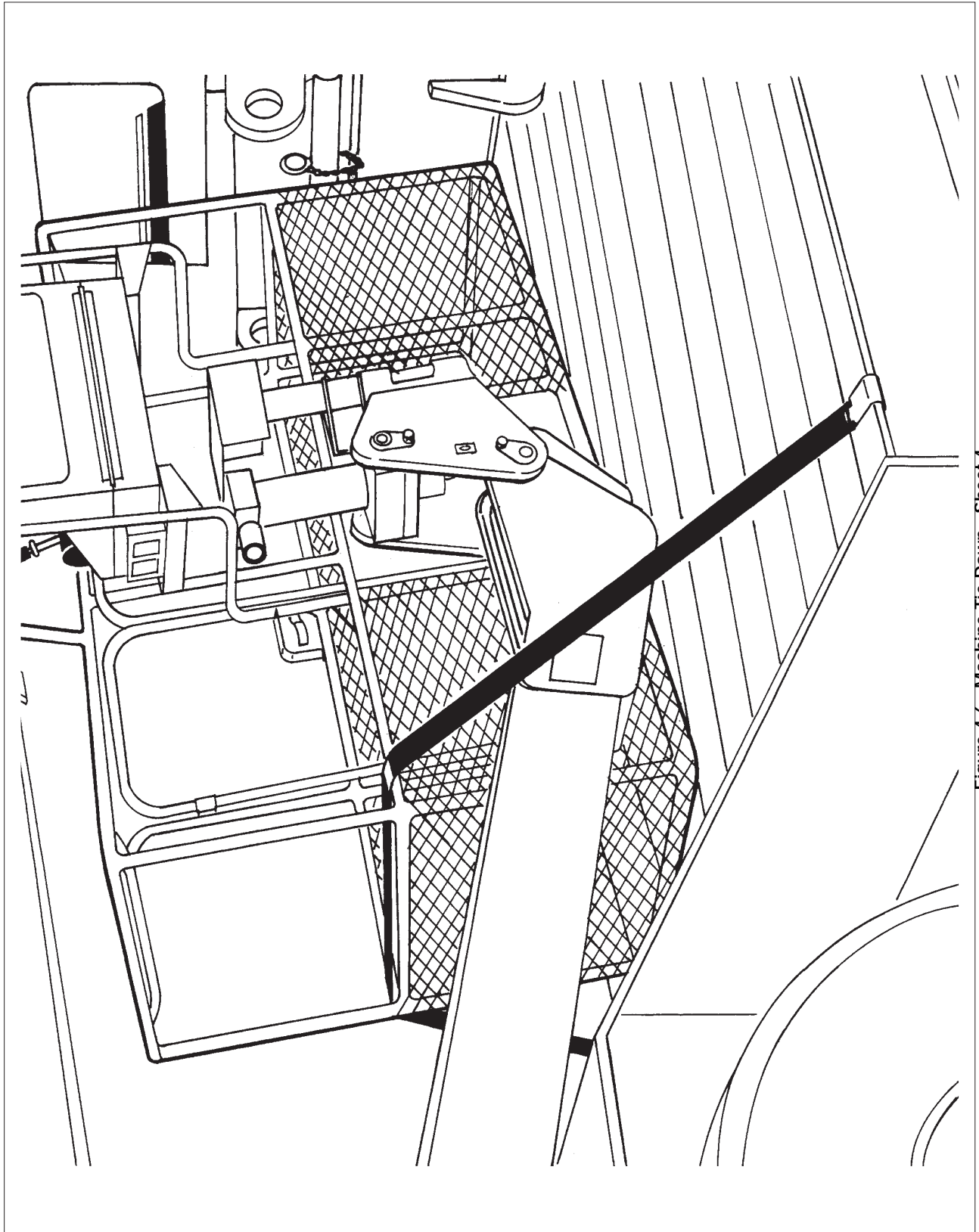

Figure 4-6. Machine Tie Down - Sheet 4

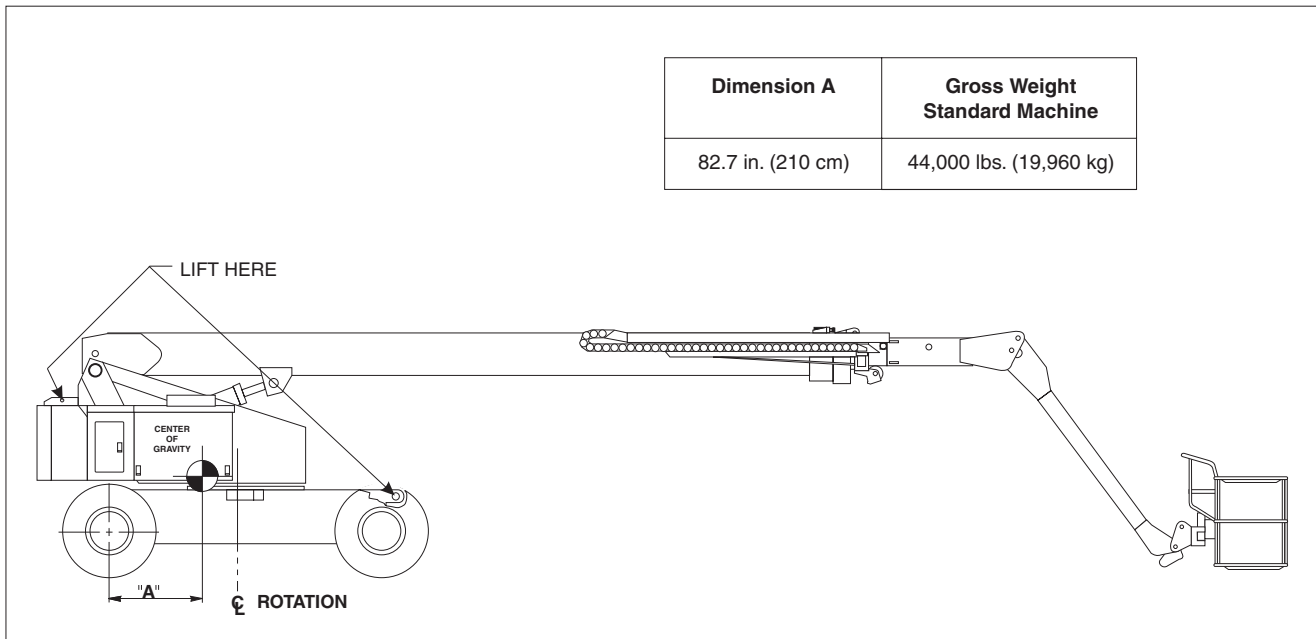

Figure 4-7. Lifting Chart  
This page left blank intentionally.

**⚠ IMPORTANT**

SECURE TURNTABLE WITH TURNTABLE LOCK BEFORE TRAVELING LONG DISTANCES OR HAULING MACHINE ON TRUCK/TRAILER.

3. Install the lockpin through aligned holes in the jib plates. The machine can now be operated from the platform controls.

## 4.11 SWING-AWAY JIB

### To Erect the Jib

1. Remove the lockpin from the jib plates.
2. With the aid of an assistant, swing the jib until straight with the boom and the holes in the jib plates align.

### To Stow the Jib

1. Remove the lockpin from the jib plates.
2. With the aid of an assistant, swing the jib closed until its alongside the boom and the holes in the jib plates align.
3. Install the lockpin through the aligned holes in the jib plates. The machine must now be operated from the ground controls or the remote control box.



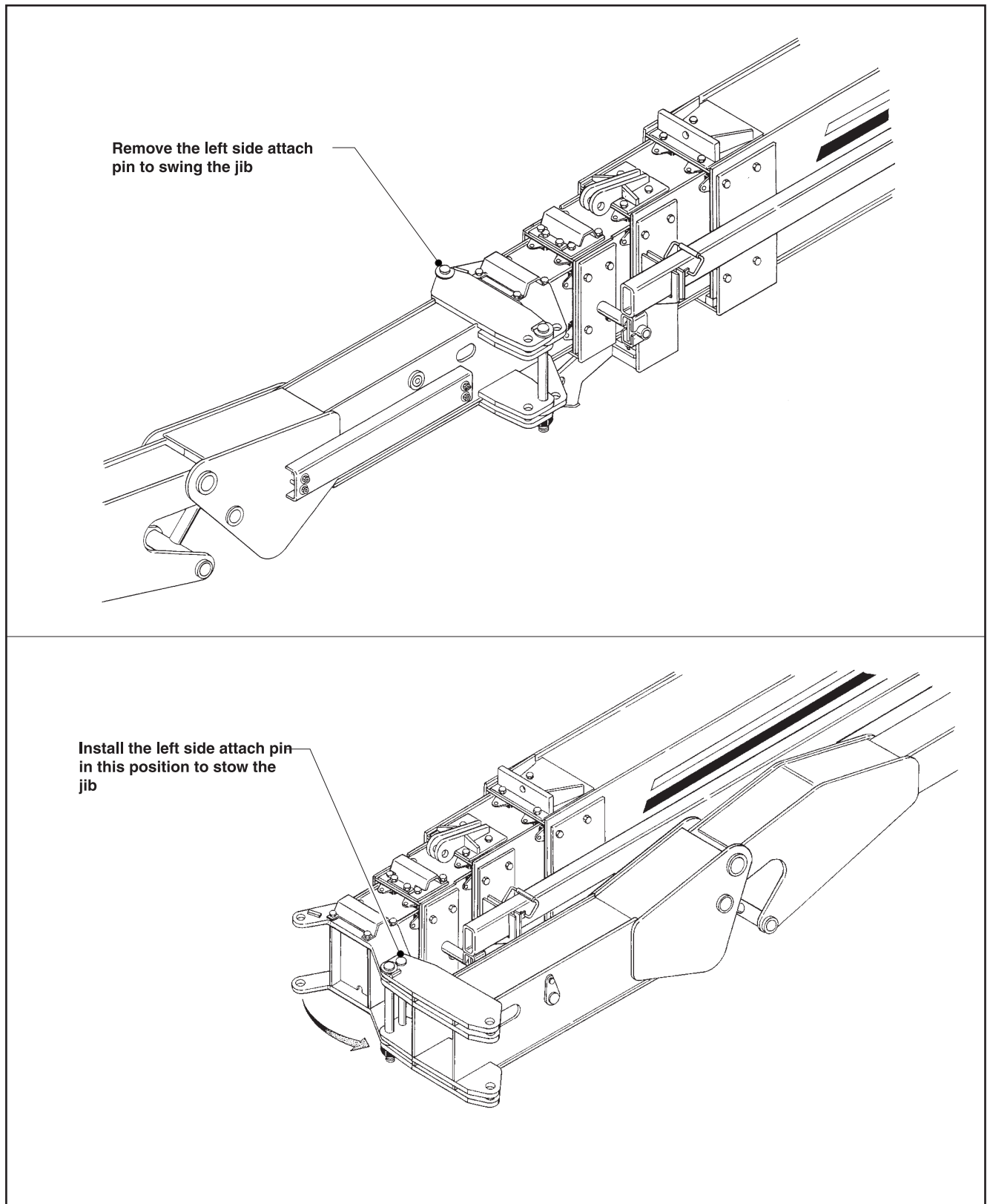

Figure 4-8. Swing-Away Jib



## SECTION 5. OPTIONAL EQUIPMENT

---

### 5.1 COLD START KIT (DIESEL ENGINE)

A cold weather start system for the diesel engine functions automatically to provide starting fluid, as necessary, to the engine during starting. A sensor switch mounted on the engine will permit ether injection into the air intake when the engine is cold. A temperature sensor will not permit ether injection into a cold engine.

---

### 5.2 TRAVEL/MOTION ALARM

A 12-volt alarm horn, mounted on the turntable, provides an audible warning when the machine is in the travel (DRIVE) mode. It will function in FORWARD or REVERSE to warn jobsite personnel the machine is traveling.

---

### 5.3 TILT ALARM

Senses when the machine is out of level in any direction approximately 5 degrees and illuminates a warning light at the platform control station and sounds the machine's horn, signaling the operator. A second switch mounted on the machine senses when the machine is out of level 5 degrees and will cut out two speed drive when activated.

---

### 5.4 ROTATING BEACON

An amber or red rotating beacon may be installed on the hood or platform, and can be controlled by a two position toggle switch mounted on the platform control console. When the switch is placed in the ON position, the light is activated and provides a visual warning to the machine's operation.

---

### 5.5 HOSTILE ENVIRONMENT PACKAGE

The hostile environment package provides additional protection against the entry of dust, dirt, sand and other abrasive materials into the hydraulic system, control handles and switches, cylinders, boom wire ropes and wear pads, and the air inlet of the engine. The package is intended for machines that will be exposed to painting, sandblasting or other similar hostile conditions. The hostile environment package includes boom wipers, cylinder bellows, heavy duty reservoir breather, an engine air cleaner and control console cover, as required.

---

### 5.6 110 VOLT GENERATOR

A 110 volt generator, mounted beside the engine, is belt driven from the output shaft of the engine. This application provides for a 110 volt receptacle at the ground control and also at the platform. The lead from the ground control and also at the platform. The lead from the ground control to the platform is routed along the boom power track thus eliminating the use of extension cords hanging freely from the platform.

**This page left blank intentionally.**

## SECTION 6. EMERGENCY PROCEDURES

### 6.1 GENERAL

This section provides information on the procedures to be followed and on the systems and controls to be used in the event an emergency situation is encountered during machine operation. Prior to operation of the machine and periodically thereafter, the entire operating manual, including this section, should be reviewed by all personnel whose responsibilities include any work or contact with the machine.

### 6.2 EMERGENCY TOWING PROCEDURES

Towing this machine is prohibited, unless properly equipped. However, provisions for moving the machine, in case of a malfunction or power failure, have been incorporated. The following procedures are to be used **ONLY** for emergency movement to a suitable maintenance area.

1. Chock wheels securely.
2. Disengage drive hubs by reversing disconnect caps.
3. Connect suitable equipment, remove chocks, and move machine.

After moving machine, complete the following procedures:

1. Position machine on a firm and level surface.
2. Chock wheels securely.
3. Engage drive hubs by reversing disconnect caps on hubs.
4. Remove chocks from wheels as needed.

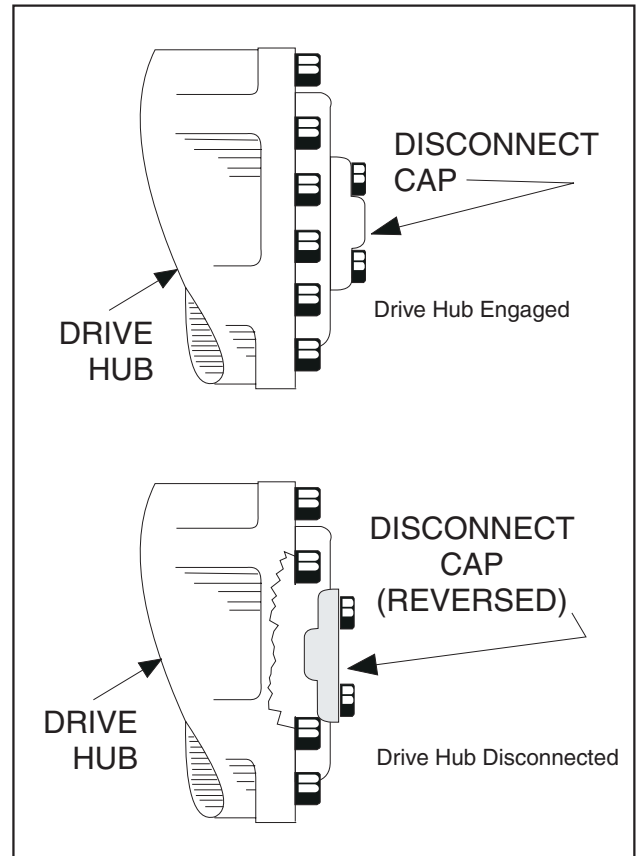

Figure 6-1. Disconnecting the Drive Hubs

### 6.3 EMERGENCY CONTROLS AND THEIR LOCATIONS

#### Emergency Stop Switches

There is an emergency stop switch at both the Ground Controls and Platform Controls. When positioned to OFF it will immediately stop the machine.

#### **⚠ WARNING**

CHECK MACHINE DAILY TO MAKE SURE EMERGENCY STOP SWITCH GUARD IS IN PLACE AND THAT GROUND CONTROL INSTRUCTIONS ARE IN PLACE AND LEGIBLE.

### Ground Control Station

---

The Ground Control Station is located on the right front side of the turntable. The controls on this panel provide the means for overriding the platform controls, and for controlling the platform level, boom and swing functions from the ground. Place the SELECT switch to GROUND position and operate the proper switch to lift, swing, or telescope the boom, or level the platform.

### Auxiliary Power

---

A toggle type auxiliary power control switch is located on the platform control station and another is located on the ground control station. Operation of either switch turns on the electrically driven auxiliary hydraulic pump. This should be used in case of failure of the main power plant. The auxiliary pump will operate boom lift, telescope and swing. To activate auxiliary power:

1. Position the platform/ground SELECT SWITCH to PLATFORM.
2. Position the EMERGENCY STOP switch to ON.
3. Depress and hold footswitch.
4. Operate appropriate control switch, lever or controller for desired function and hold.
5. Position the AUXILIARY POWER switch to ON and hold.
6. Release the AUXILIARY POWER switch, selected control switch, lever or controller, and footswitch.
7. Position the EMERGENCY STOP switch to OFF.

To activate auxiliary power from the ground control station:

1. Position the platform/ground SELECT SWITCH to GROUND.
2. Position EMERGENCY STOP switch to ON.
3. Operate appropriate control switch or controller for desired function and hold.
4. Position the AUXILIARY POWER switch to ON and hold.
5. Release the AUXILIARY POWER switch, and appropriate control switch or controller.
6. Position the EMERGENCY STOP switch to OFF.

### Remote Control Box

---

The remote control box is located behind the left rear access door on the turntable. To use these controls, the engine must be running and the SELECT SWITCH must be in the ground position.

1. Pull the POWER/EMERGENCY STOP out.

2. To steer, push the steer switch to the left or to the right.
3. To drive, push the drive switch to forward or reverse.
4. The speed control switch controls the speed of the drive function. Rotate the switch to increase or decrease the drive speed.

---

## 6.4 EMERGENCY OPERATION

### Use of Ground/Remote Controls

---

#### KNOW HOW TO USE THE GROUND CONTROLS IN AN EMERGENCY SITUATION.

Ground personnel must be thoroughly familiar with the machine operating characteristics and the ground control functions. Training should include operation of the machine, review and understanding of this section and hands-on operation of the controls in simulated emergencies.

### Operator Unable to Control Machine

---

#### IF THE PLATFORM OPERATOR IS UNABLE TO OPERATE OR CONTROL THE MACHINE FOR ANY REASON:

#### **WARNING**

DO NOT OPERATE WITH PRIMARY POWER SOURCE (ENGINE) IF PERSONS ARE PINNED OR TRAPPED. USE AUXILIARY POWER INSTEAD.

1. Operate the machine from ground controls ONLY with the assistance of other personnel and equipment (cranes, overhead hoists, etc.) as may be required to safely remove the danger or emergency condition.
2. Other qualified personnel on the platform may use the platform controls with regular or auxiliary power. DO NOT CONTINUE OPERATION IF CONTROLS DO NOT FUNCTION NORMALLY.
3. Cranes, forklift trucks or other equipment which may be available are to be used to remove platform occupants and stabilize motion of the machine in case machine controls are inadequate or malfunction when used.

### Platform or Boom Caught Overhead

---

If the platform or boom becomes jammed or snagged in overhead structures or equipment, do not continue operation of the machine from either the platform or the ground until the operator and all personnel are safely moved to a secure location. Only then should an attempt be made to free the platform using any necessary equipment and personnel. Do not operate controls to cause one or more wheels to leave the ground.

### **Righting a Tipped Machine**

---

No attempt should be made to right the machine using platform or ground controls. A fork truck of suitable capacity or equivalent equipment may be placed under the elevated side of the chassis. A crane or other lifting equipment may also be used to lift the platform while the chassis is lowered by a fork truck, jacks, or other means. Remove all personnel and equipment from the area before starting operation.

### **Post Incident Inspection and Repair**

---

Following any incident, thoroughly inspect the machine and test all functions first from the ground controls, then from the platform controls. Do not lift above 10 feet (3 m) until you are sure that all damage has been repaired, if required, and that all controls are operating correctly.

---

## **6.5 INCIDENT NOTIFICATION**

It is imperative that JLG Industries, Inc. be notified immediately of any incident involving a JLG product. Even if no injury or property damage is evident, the factory should be contacted by telephone and provided with all necessary details.

JLG Phone: 877-JLG-SAFE (554-7233)  
(8am till 4:45pm EST)

It should be noted that failure to notify the manufacturer of an incident involving a JLG Industries product within 48 hours of such an occurrence may void any warranty consideration on that particular machine.

**This page left blank intentionally.**









# TRANSFER OF OWNERSHIP

To: JLG, Gradall, Lull and Sky Trak product owner:

If you now own, but ARE NOT the original purchaser of the product covered by this manual, we would like to know who you are. For the purpose of receiving safety-related bulletins, it is very important to keep JLG Industries, Inc. updated with the current ownership of all JLG products. JLG maintains owner information for each JLG product and uses this information in cases where owner notification is necessary.

Please use this form to provide JLG with updated information with regard to the current ownership of JLG Products. Please return completed form to the JLG Product Safety & Reliability Department via facsimile (717) 485-6573 or mail to address as specified on the back of this form.

Thank you,  
Product Safety & Reliability Department  
JLG Industries, Inc.  
1 JLG Drive  
McConnellsburg, PA 17233-9533  
Telephone: (717) 485-5161  
Fax: (717) 485-6573

NOTE: Leased or rented units should not be included on this form.

Mfg. Model: \_\_\_\_\_

Serial Number: \_\_\_\_\_

Previous Owner: \_\_\_\_\_

Address: \_\_\_\_\_

City: \_\_\_\_\_ State: \_\_\_\_\_

Zip: \_\_\_\_\_ Telephone: ( \_\_\_\_\_ ) \_\_\_\_\_

Date Of Transfer: \_\_\_\_\_

Current Owner: \_\_\_\_\_

Address: \_\_\_\_\_

City: \_\_\_\_\_ State: \_\_\_\_\_

Zip: \_\_\_\_\_ Telephone: ( \_\_\_\_\_ ) \_\_\_\_\_

Who in your organization should we notify?

Name: \_\_\_\_\_

Title: \_\_\_\_\_

Please cut on the dotted line and fax to 717-485-6573









Corporate Office  
JLG Industries, Inc.  
1 JLG Drive  
McConnellsburg PA. 17233-9533  
USA  
Phone: (717) 485-5161  
Fax: (717) 485-6417

## JLG Worldwide Locations

---

JLG Industries (Australia)  
P.O. Box 5119  
11 Bolwarra Road  
Port Macquarie  
N.S.W. 2444  
Australia  
Phone: (61) 2 65 811111  
Fax: (61) 2 65 810122

JLG Industries (UK)  
Unit 12, Southside  
Bredbury Park Industrial Estate  
Bredbury  
Stockport  
SK6 2sP  
England  
Phone: (44) 870 200 7700  
Fax: (44) 870 200 7711

JLG Deutschland GmbH  
Max Planck Strasse 21  
D-27721 Ritterhude/Idpohl  
Bei Bremen  
Germany  
Phone: (49) 421 693 500  
Fax: (49) 421 693 5035

JLG Industries (Italia)  
Via Po. 22  
20010 Pregnana Milanese - MI  
Italy  
Phone: (39) 02 9359 5210  
Fax: (39) 02 9359 5845

JLG Latino Americana Ltda.  
Rua Eng. Carlos Stevenson,  
80-Suite 71  
13092-310 Campinas-SP  
Brazil  
Phone: (55) 19 3295 0407  
Fax: (55) 19 3295 1025

JLG Europe B.V.  
Jupiterstraat 234  
2132 HJ Foofddorp  
The Netherlands  
Phone: (31) 23 565 5665  
Fax: (31) 23 557 2493

JLG Industries (Norge AS)  
Sofeimyrveien 12  
N-1412 Sofienyr  
Norway  
Phone: (47) 6682 2000  
Fax: (47) 6682 2001

JLG Polska  
Ul. Krolewska  
00-060 Warszawa  
Poland  
Phone: (48) 91 4320 245  
Fax: (48) 91 4358 200

JLG Industries (Europe)  
Kilmartin Place,  
Tannochside Park  
Uddingston G71 5PH  
Scotland  
Phone: (44) 1 698 811005  
Fax: (44) 1 698 811055

JLG Industries (Pty) Ltd.  
Unit 1, 24 Industrial Complex  
Herman Street  
Meadowdale  
Germiston  
South Africa  
Phone: (27) 11 453 1334  
Fax: (27) 11 453 1342

Plataformas Elevadoras  
JLG Iberica, S.L.  
Trapadella, 2  
P.I. Castellbisbal Sur  
08755Castellbisbal  
Spain  
Phone: (34) 93 77 24700  
Fax: (34) 93 77 11762

JLG Industries (Sweden)  
Enkopingsvagen 150  
Box 704  
SE - 175 27 Jarfalla  
Sweden  
Phone: (46) 8 506 59500  
Fax: (46) 8 506 59534

---