



Service Manual

Models

TL642

TL943

S/N TBK00100 & After
S/N TBL00100 & After

31200292

Revised
May 21, 2012

EFFECTIVITY PAGE

September 29, 2006 - A - Original Issue Of Manual

August 3, 2007 - B - Revised pages 2-6, 2-7, 2-8, 2-9, 4-2, 4-7, 4-8, 8-5, 8-8 & 8-9.

March 31, 2011 - C - Revised pages 2-3 thru 2-9, 2-11 thru 2-21, 3-1 thru 3-25, 4-2 thru 4-9, 5-3, 6-3, 7-3 thru 7-5, 7-7, 7-9 thru 7-11, 8-2, 8-3, 8-7 thru 8-12, 8-14 thru 8-16, 8-25, 8-26, 9-2 thru 9-6, 9-8 thru 9-22, 9-29, 9-30 & 9-33 thru 9-46.

September 22, 2011 - D - Added pages 9-41 thru 9-46.

May 21, 2012 - E - Revised pages 2-11, 8-4, 8-5, 8-6 & 8-8.

EFFECTIVITY PAGE

SECTION CONTENTS

Section	Subject	Page
Section 1		
Safety Practices		1-1
1.1	Introduction	1-2
1.2	Disclaimer	1-2
1.3	Operation & Maintenance Manual	1-2
1.4	Do Not Operate Tags	1-2
1.5	Safety Information	1-2
1.6	Safety Instructions	1-3
1.7	Safety Decals	1-4
Section 2		
General Information and Specifications		2-1
2.1	Replacement Parts and Warranty Information	2-2
2.2	Torque Charts	2-3
2.3	Specifications	2-11
2.4	Fluids and Lubricant Capacities	2-14
2.5	Service and Maintenance Schedules	2-17
2.6	Lubrication Schedules	2-20
Section 3		
Boom		3-1
3.1	Boom System Component Terminology	3-3
3.2	Boom System - Three Section	3-4
3.3	Boom Assembly Maintenance	3-4
3.4	Complete Boom Removal/Installation	3-5
3.5	Boom Section Removal/Installation	3-6
3.6	Extend/Retract Chain Removal/Installation	3-14
3.7	Push Beam - Extend/Retract Cylinder Removal/Installation	3-16
3.8	Boom Section Separation Adjustment	3-20
3.9	Quick Coupler Assembly	3-20
3.10	Boom Head - Mounted Winch	3-22
3.11	Boom Wear Pads	3-23
3.12	Boom Extend and Retract Chains	3-24
3.13	Forks	3-27
3.14	Troubleshooting	3-28
3.15	Push Beam Temporary Brackets	3-31

Section	Subject	Page
Section 4		
Cab and Covers		4-1
4.1	Operator Cab and Covers Component Terminology	4-2
4.2	Operator Cab	4-4
4.3	Cab Components	4-4
4.4	Cab Removal	4-10
4.5	Cab Installation	4-11
Section 5		
Axles, Drive Shafts, Wheels and Tires		5-1
5.1	Axles, Drive Shafts, Wheels and Tires Component Terminology	5-2
5.2	General Information	5-3
5.3	Axle Assemblies	5-3
5.4	Drive Shafts	5-9
5.5	Wheels and Tires	5-10
5.6	Brakes	5-11
5.7	Towing a Disabled machine	5-11
Section 6		
Transmission		6-1
6.1	Transmission Assembly Component Terminology	6-2
6.2	Transmission Serial Number	6-3
6.3	Transmission Specifications and Maintenance Information	6-3
6.4	Transmission Replacement	6-3
6.5	Torque Converter Diaphragm	6-6
6.6	Troubleshooting	6-7
Section 7		
Engine		7-1
7.1	Introduction	7-2
7.2	Engine Serial Number	7-4
7.3	Specifications and Maintenance Information	7-4
7.4	Engine Cooling System	7-4
7.5	Engine Electrical System	7-6
7.6	Fuel System	7-7
7.7	Engine Exhaust System	7-8
7.8	Air Cleaner Assembly	7-9
7.9	Engine Replacement	7-10
7.10	Engine Drive Plate	7-13
7.11	Troubleshooting	7-14

Section	Subject	Page
Section 8		
Hydraulic System		8-1
8.1	Hydraulic Component Terminology	8-2
8.2	Safety Information	8-3
8.3	Hydraulic Pressure Diagnosis	8-3
8.4	Hydraulic Circuits	8-4
8.5	Hydraulic Reservoir	8-14
8.6	Engine Implement Pump	8-15
8.7	Control Valves	8-18
8.8	Hydraulic Cylinders	8-24
Section 9		
Electrical System		9-1
9.1	Electrical Component Terminology	9-3
9.2	Specifications	9-5
9.3	Safety Information	9-5
9.4	Fuses and Relays	9-5
9.5	Electrical System Schematics	9-11
9.6	Circuit Breakdowns	9-23
9.7	Engine Start Circuit	9-26
9.8	Charging Circuit	9-27
9.9	Window Wiper/Washer Windshield Wiper Motor	9-28
9.10	Cab Heater/AC and Fan	9-29
9.11	Switches, Solenoids and Senders	9-30
9.12	Gauges and Display Monitor	9-34
9.13	Dash Switches	9-36
9.14	Hand Held Analyzer (S/N TBL01599 & After including TBL01551 & TBL01585)	9-38
9.15	Engine Diagnostic and Event Codes (S/N TBK01167 & After including TBK01162; S/N TBL01599 & After including TBL01551 & TBL01585)	9-47



Section 1

Safety Practices

Contents

PARAGRAPH	TITLE	PAGE
1.1	Introduction	1-2
1.2	Disclaimer	1-2
1.3	Operation & Maintenance Manual	1-2
1.4	Do Not Operate Tags	1-2
1.5	Safety Information	1-2
1.5.1	Safety Alert System and Signal Words	1-2
1.6	Safety Instructions	1-3
1.6.1	Personal Hazards	1-3
1.6.2	Equipment Hazards	1-3
1.6.3	General Hazards	1-3
1.6.4	Operational Hazards	1-4
1.7	Safety Decals	1-4



Safety Practices

1.1 INTRODUCTION

This service manual provides general directions for accomplishing service and repair procedures. Following the procedures in this manual will help assure safety and equipment reliability.

Read, understand and follow the information in this manual, and obey all locally approved safety practices, procedures, rules, codes, regulations and laws.

These instructions cannot cover all details or variations in the equipment, procedures, or processes described, nor provide directions for meeting every possible contingency during operation, maintenance, or testing. When additional information is desired consult the local Caterpillar dealer.

Many factors contribute to unsafe conditions: carelessness, fatigue, overload, inattentiveness, unfamiliarity, even drugs and alcohol, among others. For optimal safety, encourage everyone to think, and to act, safely.

Appropriate service methods and proper repair procedures are essential for the safety of the individual doing the work, for the safety of the operator, and for the safe, reliable operation of the machine. All references to the right side, left side, front and rear are given from the operator seat looking in a forward direction.

Supplementary information is available from the manufacturer in the form of Service Bulletins, Service Campaigns, Service Training Schools, the service website, other literature, and through updates to the manual itself.

1.2 DISCLAIMER

All information in this manual is based on the latest product information available at the time of publication. The manufacturer reserves the right to make changes and improvements to its products, and to discontinue the manufacture of any product, at its discretion at any time without public notice or obligation.

1.3 OPERATION & MAINTENANCE MANUAL

The mechanic must not operate the machine until the Operation & Maintenance Manual has been read & understood, training has been accomplished and operation of the machine has been completed under the supervision of an experienced and qualified operator.

An Operation & Maintenance Manual is supplied with each machine and must be kept in the manual holder located in the cab. In the event that the Operation & Maintenance Manual is missing, consult your local service distributor before proceeding.

1.4 DO NOT OPERATE TAGS

Place Do Not Operate Tags on the ignition key switch and the steering wheel before attempting to perform any service or maintenance. Remove key and disconnect battery leads.

1.5 SAFETY INFORMATION

To avoid possible death or injury, carefully read, understand and comply with all safety messages.

In the event of an accident, know where to obtain medical assistance and how to use a first-aid kit and fire extinguisher/fire suppression system. Keep emergency telephone numbers (fire department, ambulance, rescue squad/paramedics, police department, etc.) nearby. If working alone, check with another person routinely to help assure personal safety.

1.5.1 Safety Alert System and Signal Words

 **DANGER**

DANGER indicates an imminently hazardous situation which, if not avoided, will result in death or serious injury.

 **WARNING**

WARNING indicates a potentially hazardous situation which, if not avoided, could result in death or serious injury.

 **CAUTION**

CAUTION indicates a potentially hazardous situation which, if not avoided, may result in minor or moderate injury.



1.6 SAFETY INSTRUCTIONS

Following are general safety statements to consider **before** performing maintenance procedures on the telehandler. Additional statements related to specific tasks and procedures are located throughout this manual and are listed prior to any work instructions to provide safety information before the potential of a hazard occurs.

For all safety messages, carefully read, understand and follow the instructions **before** proceeding.

1.6.1 Personal Hazards

PERSONAL SAFETY GEAR: Wear all the protective clothing and personal safety gear necessary to perform the job safely. This might include heavy gloves, safety glasses or goggles, filter mask or respirator, safety shoes or a hard hat.

LIFTING: **NEVER** lift a heavy object without the help of at least one assistant or a suitable sling and hoist.

1.6.2 Equipment Hazards

LIFTING OF EQUIPMENT: Before using any lifting equipment (chains, slings, brackets, hooks, etc.), verify that it is of the proper capacity, in good working order, and is properly attached.

NEVER stand or otherwise become positioned under a suspended load or under raised equipment. The load or equipment could fall or tip.

DO NOT use a hoist, jack or jack stands only to support equipment. Always support equipment with the proper capacity blocks or stands properly rated for the load.

HAND TOOLS: Always use the proper tool for the job; keep tools clean and in good working order, and use special service tools only as recommended.

1.6.3 General Hazards

SOLVENTS: Only use approved solvents that are known to be safe for use.

HOUSEKEEPING: Keep the work area and operator cab clean, and remove all hazards (debris, oil, tools, etc.).

FIRST AID: Immediately clean, dress and report all injuries (cuts, abrasions, burns, etc.), no matter how minor the injury may seem. Know the location of a First Aid Kit, and know how to use it.

CLEANLINESS: Wear eye protection, and clean all components with a high-pressure or steam cleaner before attempting service.

When removing hydraulic components, plug hose ends and connections to prevent excess leakage and contamination. Place a suitable catch basin beneath the machine to capture fluid run-off.

It is good practice to avoid pressure-washing electrical/electronic components. In the event pressure-washing the machine is needed, ensure the machine is shut down before pressure-washing. Should pressure-washing be utilized to wash areas containing electrical/electronic components, it is recommended a maximum pressure of 750 psi (52 bar) at a minimum distance of 12 in (30,5 cm) away from these components. If electrical/electronic components are sprayed, spraying must not be direct and for brief time periods to avoid heavy saturation,

Check and obey all Federal, State and/or Local regulations regarding waste storage, disposal and recycling.



Safety Practices

1.6.4 Operational Hazards

ENGINE: Stop the engine before performing any service unless specifically instructed otherwise.

VENTILATION: Avoid prolonged engine operation in enclosed areas without adequate ventilation.

SOFT SURFACES AND SLOPES: **NEVER** work on a machine that is parked on a soft surface or slope. The machine must be on a hard level surface, with the wheels blocked before performing any service.

FLUID TEMPERATURE: **NEVER** work on a machine when the engine, cooling or hydraulic systems are hot. Hot components and fluids can cause severe burns. Allow systems to cool before proceeding.

FLUID PRESSURE: Before loosening any hydraulic or diesel fuel component, hose or tube, turn the engine OFF. Wear heavy, protective gloves and eye protection. **NEVER** check for leaks using any part of your body; use a piece of cardboard or wood instead. If injured, seek medical attention immediately. Diesel fluid leaking under pressure can explode. Hydraulic fluid and diesel fuel leaking under pressure can penetrate the skin, cause infection, gangrene and other serious personal injury.

Relieve all pressure before disconnecting any component, part, line or hose. Slowly loosen parts and allow release of residual pressure before removing any part or component. Before starting the engine or applying pressure, use components, parts, hoses and pipes that are in good condition, connected properly and are tightened to the proper torque. Capture fluid in an appropriate container and dispose of in accordance with prevailing environmental regulations.

RADIATOR CAP: The cooling system is under pressure, and escaping coolant can cause severe burns and eye injury. To prevent personal injury, **NEVER** remove the radiator cap while the cooling system is hot. Wear safety glasses. Turn the radiator cap to the first stop and allow pressure to escape before removing the cap completely. Failure to follow the safety practices could result in death or serious injury.

FLUID FLAMABILITY: **DO NOT** service the fuel or hydraulic systems near an open flame, sparks or smoking materials.

NEVER drain or store fluids in an open container. Engine fuel and hydraulic fluid are flammable and can cause a fire and/or explosion.

DO NOT mix gasoline or alcohol with diesel fuel. The mixture can cause an explosion.

PRESSURE TESTING: When conducting any test, only use test equipment that is correctly calibrated and in good condition. Use the correct equipment in the proper manner, and make changes or repairs as indicated by the test procedure to achieve the desired result.

LEAVING MACHINE: Lower the forks or attachment to the ground before leaving the machine.

TIRES: Always keep tires inflated to the proper pressure to help prevent tipover. **DO NOT** over-inflate tires.

NEVER use mismatched tire types, sizes or ply ratings. Always use matched sets according to machine specifications.

MAJOR COMPONENTS: Never alter, remove, or substitute any items such as counterweights, tires, batteries or other items that may reduce or affect the overall weight or stability of the machine.

BATTERY: **DO NOT** charge a frozen battery. Charging a frozen battery may cause it to explode. Allow the battery to thaw before jump-starting or connecting a battery charger.

1.7 SAFETY DECALS

Check that all safety decals are present and readable on the machine. Refer to the Operation & Maintenance Manual supplied with machine for information.



Section 2

General Information and Specifications

PARAGRAPH	TITLE	PAGE
2.1	Replacement Parts and Warranty Information	2-2
2.2	Torque Charts	2-3
2.2.1	SAE Fastener Torque Chart	2-3
2.2.2	Metric Fastener Torque Chart	2-7
2.2.3	Hydraulic Hose Torque Chart	2-10
2.3	Specifications	2-11
2.3.1	Travel Speeds	2-11
2.3.2	Hydraulic Cylinder Performance	2-11
2.3.3	Cylinder Drift	2-11
2.3.4	Electrical System	2-12
2.3.5	Engine Performance Specifications	2-12
2.3.6	Tires	2-13
2.4	Fluids and Lubricant Capacities	2-14
2.5	Service and Maintenance Schedules	2-17
2.5.1	10, 1st 50 & 50 Hour	2-17
2.5.2	1st 250, 250 & 500 Hour	2-18
2.5.3	1000 & 1500 Hour	2-19
2.6	Lubrication Schedules	2-20



2.1 REPLACEMENT PARTS AND WARRANTY INFORMATION

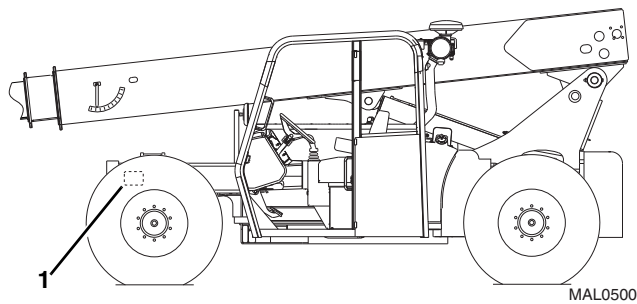

Before ordering parts or initiating service inquiries, make note of the machine serial number. The machine serial number plate (1) is located as indicated in the figure.

Note: *The replacement of any part on this machine with any other than factory authorized replacement parts can adversely affect the performance, durability, or safety of the machine, and will void the warranty. JLG disclaims liability for any claims or damages, whether regarding property damage, personal injury or death arising out of the use of unauthorized replacement parts.*

A warranty registration form must be filled out by the local Caterpillar dealer, signed by the purchaser and returned to the manufacturer when the machine is sold and/or put into use.

Registration activates the warranty period and helps to assure that warranty claims are promptly processed. To guarantee full warranty service, verify that the service distributor has returned the business reply card of the warranty registration form to the manufacturer.



2.2 TORQUE CHARTS

2.2.1 SAE Fastener Torque Chart

Values for Zinc Yellow Chromate Fasteners (Ref 4150707)												
SAE GRADE 5 BOLTS & GRADE 2 NUTS												
Size	TPI	Bolt Dia	Tensile Stress Area	Clamp Load	Torque (Dry)		Torque Lubricated		Torque (Loctite® 242™ or 271™ OR Vibra-TITE™ 111 or 140)		Torque (Loctite® 262™ or Vibra-TITE™ 131)	
					IN-LB	[N.m]	IN-LB	[N.m]	IN-LB	[N.m]	IN-LB	[N.m]
		In	Sq In	LB	IN-LB	[N.m]	IN-LB	[N.m]	IN-LB	[N.m]	IN-LB	[N.m]
4	40	0.1120	0.00604	380	8	0.9	6	0.7				
	48	0.1120	0.00661	420	9	1.0	7	0.8				
6	32	0.1380	0.00909	580	16	1.8	12	1.4				
	40	0.1380	0.01015	610	18	2.0	13	1.5				
8	32	0.1640	0.01400	900	30	3.4	22	2.5				
	36	0.1640	0.01474	940	31	3.5	23	2.6				
10	24	0.1900	0.01750	1120	43	4.8	32	3.5				
	32	0.1900	0.02000	1285	49	5.5	36	4				
1/4	20	0.2500	0.0318	2020	96	10.8	75	9	105	12		
	28	0.2500	0.0364	2320	120	13.5	86	10	135	15		
		In	Sq In	LB	FT-LB	[N.m]	FT-LB	[N.m]	FT-LB	[N.m]	FT-LB	[N.m]
5/16	18	0.3125	0.0524	3340	17	23	13	18	19	26	16	22
	24	0.3125	0.0580	3700	19	26	14	19	21	29	17	23
3/8	16	0.3750	0.0775	4940	30	41	23	31	35	48	28	38
	24	0.3750	0.0878	5600	35	47	25	34	40	54	32	43
7/16	14	0.4375	0.1063	6800	50	68	35	47	55	75	45	61
	20	0.4375	0.1187	7550	55	75	40	54	60	82	50	68
1/2	13	0.5000	0.1419	9050	75	102	55	75	85	116	68	92
	20	0.5000	0.1599	10700	90	122	65	88	100	136	80	108
9/16	12	0.5625	0.1820	11600	110	149	80	108	120	163	98	133
	18	0.5625	0.2030	12950	120	163	90	122	135	184	109	148
5/8	11	0.6250	0.2260	14400	150	203	110	149	165	224	135	183
	18	0.6250	0.2560	16300	170	230	130	176	190	258	153	207
3/4	10	0.7500	0.3340	21300	260	353	200	271	285	388	240	325
	16	0.7500	0.3730	23800	300	407	220	298	330	449	268	363
7/8	9	0.8750	0.4620	29400	430	583	320	434	475	646	386	523
	14	0.8750	0.5090	32400	470	637	350	475	520	707	425	576
1	8	1.0000	0.6060	38600	640	868	480	651	675	918	579	785
	12	1.0000	0.6630	42200	700	949	530	719	735	1000	633	858
1 1/8	7	1.1250	0.7630	42300	800	1085	600	813	840	1142	714	968
	12	1.1250	0.8560	47500	880	1193	660	895	925	1258	802	1087
1 1/4	7	1.2500	0.9690	53800	1120	1518	840	1139	1175	1598	1009	1368
	12	1.2500	1.0730	59600	1240	1681	920	1247	1300	1768	1118	1516
1 3/8	6	1.3750	1.1550	64100	1460	1979	1100	1491	1525	2074	1322	1792
	12	1.3750	1.3150	73000	1680	2278	1260	1708	1750	2380	1506	2042
1 1/2	6	1.5000	1.4050	78000	1940	2630	1460	1979	2025	2754	1755	2379
	12	1.5000	1.5800	87700	2200	2983	1640	2224	2300	3128	1974	2676

NO. 5000059 REV. J

- NOTES: 1. THESE TORQUE VALUES DO NOT APPLY TO CADMIUM PLATED FASTENERS
 2. ALL TORQUE VALUES ARE STATIC TORQUE MEASURED PER STANDARD AUDIT METHODS TOLERANCE = ±10%
 3. * ASSEMBLY USES HARDENED WASHER

MY3141



General Information and Specifications

2.2.1 SAE Fastener Torque Chart (Continued)

Values for Zinc Yellow Chromate Fasteners (Ref 4150707)

SAE GRADE 8 (HEX HD) BOLTS & GRADE 8 NUTS*

Size	TPI	Bolt Dia	Tensile Stress Area	Clamp Load	Torque (Dry or Loctite® 263) K= 0.20		Torque (Loctite® 242™ or 271™ OR Vibra-TITE™ 111 or 140) K= 0.18		Torque (Loctite® 262™ or Vibra-TITE™ 131) K=0.15	
					IN-LB	[N.m]	IN-LB	[N.m]	IN-LB	[N.m]
		In	Sq In	LB	FT-LB	[N.m]	FT-LB	[N.m]	FT-LB	[N.m]
4	40	0.1120	0.00604							
	48	0.1120	0.00661							
6	32	0.1380	0.00909							
	40	0.1380	0.01015							
8	32	0.1640	0.01400							
	36	0.1640	0.01474	1320	43	5				
10	24	0.1900	0.01750	1580	60	7				
	32	0.1900	0.02000	1800	68	8				
1/4	20	0.2500	0.0318	2860	143	16	129	15		
	28	0.2500	0.0364	3280	164	19	148	17		
		In	Sq In	LB	FT-LB	[N.m]	FT-LB	[N.m]	FT-LB	[N.m]
5/16	18	0.3125	0.0524	4720	25	35	20	25	20	25
	24	0.3125	0.0580	5220	25	35	25	35	20	25
3/8	16	0.3750	0.0775	7000	45	60	40	55	35	50
	24	0.3750	0.0878	7900	50	70	45	60	35	50
7/16	14	0.4375	0.1063	9550	70	95	65	90	50	70
	20	0.4375	0.1187	10700	80	110	70	95	60	80
1/2	13	0.5000	0.1419	12750	105	145	95	130	80	110
	20	0.5000	0.1599	14400	120	165	110	150	90	120
9/16	12	0.5625	0.1820	16400	155	210	140	190	115	155
	18	0.5625	0.2030	18250	170	230	155	210	130	175
5/8	11	0.6250	0.2260	20350	210	285	190	260	160	220
	18	0.6250	0.2560	23000	240	325	215	290	180	245
3/4	10	0.7500	0.3340	30100	375	510	340	460	280	380
	16	0.7500	0.3730	33600	420	570	380	515	315	430
7/8	9	0.8750	0.4620	41600	605	825	545	740	455	620
	14	0.8750	0.5090	45800	670	910	600	815	500	680
1	8	1.0000	0.6060	51500	860	1170	770	1045	645	875
	12	1.0000	0.6630	59700	995	1355	895	1215	745	1015
1 1/8	7	1.1250	0.7630	68700	1290	1755	1160	1580	965	1310
	12	1.1250	0.8560	77000	1445	1965	1300	1770	1085	1475
1 1/4	7	1.2500	0.9690	87200	1815	2470	1635	2225	1365	1855
	12	1.2500	1.0730	96600	2015	2740	1810	2460	1510	2055
1 3/8	6	1.3750	1.1550	104000	2385	3245	2145	2915	1785	2430
	12	1.3750	1.3150	118100	2705	3680	2435	3310	2030	2760
1 1/2	6	1.5000	1.4050	126500	3165	4305	2845	3870	2370	3225
	12	1.5000	1.5800	142200	3555	4835	3200	4350	2665	3625

NO. 5000059 REV. J

- NOTES: 1. THESE TORQUE VALUES DO NOT APPLY TO CADMIUM PLATED FASTENERS
 2. ALL TORQUE VALUES ARE STATIC TORQUE MEASURED PER STANDARD AUDIT METHODS TOLERANCE = ±10%
 3. * ASSEMBLY USES HARDENED WASHER

MY3151



2.2.1 SAE Fastener Torque Chart
(Continued)

SOCKET HEAD CAP SCREWS										
Magni Coating (Ref 4150701)*										
Size	TPI	Bolt Dia	Tensile Stress Area	Clamp Load See Note 4	Torque (Dry) K = .17		Torque (Loctite® 242™ or 271™ OR Vibra-TITE™ 111 or 140 OR Precoat 85® K=0.16		Torque (Loctite® 262™ or Vibra-TITE™ 131) K=0.15	
					IN-LB	[N.m]	IN-LB	[N.m]	IN-LB	[N.m]
		In	Sq In	LB						
4	40	0.1120	0.00604							
	48	0.1120	0.00661							
6	32	0.1380	0.00909							
	40	0.1380	0.01015							
8	32	0.1640	0.01400							
	36	0.1640	0.01474							
10	24	0.1900	0.01750							
	32	0.1900	0.02000							
1/4	20	0.2500	0.0318	2860	122	14	114	13		
	28	0.2500	0.0364	3280	139	16	131	15		
		In	Sq In	LB	FT-LB	[N.m]	FT-LB	[N.m]	FT-LB	[N.m]
5/16	18	0.3125	0.0524	4720	20	25	20	25	20	25
	24	0.3125	0.0580	5220	25	35	20	25	20	25
3/8	16	0.3750	0.0775	7000	35	50	35	50	35	50
	24	0.3750	0.0878	7900	40	55	40	55	35	50
7/16	14	0.4375	0.1063	9550	60	80	55	75	50	70
	20	0.4375	0.1187	10700	65	90	60	80	60	80
1/2	13	0.5000	0.1419	12750	90	120	85	115	80	110
	20	0.5000	0.1599	14400	100	135	95	130	90	120
9/16	12	0.5625	0.1820	16400	130	175	125	170	115	155
	18	0.5625	0.2030	18250	145	195	135	185	130	175
5/8	11	0.6250	0.2260	20350	180	245	170	230	160	220
	18	0.6250	0.2560	23000	205	280	190	260	180	245
3/4	10	0.7500	0.3340	30100	320	435	300	410	280	380
	16	0.7500	0.3730	33600	355	485	335	455	315	430
7/8	9	0.8750	0.4620	41600	515	700	485	660	455	620
	14	0.8750	0.5090	45800	570	775	535	730	500	680
1	8	1.0000	0.6060	51500	730	995	685	930	645	875
	12	1.0000	0.6630	59700	845	1150	795	1080	745	1015
1 1/8	7	1.1250	0.7630	68700	1095	1490	1030	1400	965	1310
	12	1.1250	0.8560	77000	1225	1665	1155	1570	1085	1475
1 1/4	7	1.2500	0.9690	87200	1545	2100	1455	1980	1365	1855
	12	1.2500	1.0730	96600	1710	2325	1610	2190	1510	2055
1 3/8	6	1.3750	1.1550	104000	2025	2755	1905	2590	1785	2430
	12	1.3750	1.3150	118100	2300	3130	2165	2945	2030	2760
1 1/2	6	1.5000	1.4050	126500	2690	3660	2530	3440	2370	3225
	12	1.5000	1.5800	142200	3020	4105	2845	3870	2665	3625

- NO. 5000059 REV. J
- NOTES: 1. THESE TORQUE VALUES DO NOT APPLY TO CADMIUM PLATED FASTENERS
 2. ALL TORQUE VALUES ARE STATIC TORQUE MEASURED PER STANDARD AUDIT METHODS TOLERANCE = ±10%
 *3. ASSEMBLY USES HARDENED WASHER OR FASTENER IS PLACED AGAINST PLATED STEEL OR RAW ALUMINUM
 4. CLAMP LOAD LISTED FOR SHCS IS SAME AS GRADE 8 OR CLASS 10.9 AND DOES NOT REPRESENT FULL STRENGTH CAPABILITY OF SHCS. IF HIGHER LOAD IS REQUIRED, ADDITIONAL TESTING IS REQUIRED.

MY3161



General Information and Specifications

2.2.1 SAE Fastener Torque Chart (Continued)

SOCKET HEAD CAP SCREWS										
Zinc Yellow Chromate Fasteners (Ref 4150707)*										
Size	TPI	Bolt Dia	Tensile Stress Area	Clamp Load See Note 4	Torque (Dry) K = .20		Torque (Loctite® 242™ or 271™ OR Vibra-TITE™ 111 or 140 OR Precoat 85® K=0.18		Torque (Loctite® 262™ or Vibra-TITE™ 131) K=0.15	
					IN-LB	[N.m]	IN-LB	[N.m]	IN-LB	[N.m]
		In	Sq In	LB	FT-LB	[N.m]	FT-LB	[N.m]	FT-LB	[N.m]
4	40	0.1120	0.00604							
	48	0.1120	0.00661							
6	32	0.1380	0.00909							
	40	0.1380	0.01015							
8	32	0.1640	0.01400							
	36	0.1640	0.01474							
10	24	0.1900	0.01750							
	32	0.1900	0.02000							
1/4	20	0.2500	0.0318	2860	143	16	129	15		
	28	0.2500	0.0364	3280	164	19	148	17		
		In	Sq In	LB	FT-LB	[N.m]	FT-LB	[N.m]	FT-LB	[N.m]
5/16	18	0.3125	0.0524	4720	25	35	20	25	20	25
	24	0.3125	0.0580	5220	25	35	25	35	20	25
3/8	16	0.3750	0.0775	7000	45	60	40	55	35	50
	24	0.3750	0.0878	7900	50	70	45	60	35	50
7/16	14	0.4375	0.1063	9550	70	95	65	90	50	70
	20	0.4375	0.1187	10700	80	110	70	95	60	80
1/2	13	0.5000	0.1419	12750	105	145	95	130	80	110
	20	0.5000	0.1599	14400	120	165	110	150	90	120
9/16	12	0.5625	0.1820	16400	155	210	140	190	115	155
	18	0.5625	0.2030	18250	170	230	155	210	130	175
5/8	11	0.6250	0.2260	20350	210	285	190	260	160	220
	18	0.6250	0.2560	23000	240	325	215	290	180	245
3/4	10	0.7500	0.3340	30100	375	510	340	460	280	380
	16	0.7500	0.3730	33600	420	570	380	515	315	430
7/8	9	0.8750	0.4620	41600	605	825	545	740	455	620
	14	0.8750	0.5090	45800	670	910	600	815	500	680
1	8	1.0000	0.6060	51500	860	1170	775	1055	645	875
	12	1.0000	0.6630	59700	995	1355	895	1215	745	1015
1 1/8	7	1.1250	0.7630	68700	1290	1755	1160	1580	965	1310
	12	1.1250	0.8560	77000	1445	1965	1300	1770	1085	1475
1 1/4	7	1.2500	0.9690	87200	1815	2470	1635	2225	1365	1855
	12	1.2500	1.0730	96600	2015	2740	1810	2460	1510	2055
1 3/8	6	1.3750	1.1550	104000	2385	3245	2145	2915	1785	2430
	12	1.3750	1.3150	118100	2705	3680	2435	3310	2030	2760
1 1/2	6	1.5000	1.4050	126500	3165	4305	2845	3870	2370	3225
	12	1.5000	1.5800	142200	3555	4835	3200	4350	2665	3625

NO. 500059 REV. J

NOTES: 1. THESE TORQUE VALUES DO NOT APPLY TO CADMIUM PLATED FASTENERS

2. ALL TORQUE VALUES ARE STATIC TORQUE MEASURED PER STANDARD AUDIT METHODS TOLERANCE = ±10%

*3. ASSEMBLY USES HARDENED WASHER OR FASTENER IS PLACED AGAINST PLATED STEEL OR RAW ALUMINUM

4. CLAMP LOAD LISTED FOR SHCS IS SAME AS GRADE 8 OR CLASS 10.9 AND DOES NOT REPRESENT FULL STRENGTH CAPABILITY OF SHCS. IF HIGHER LOAD IS REQUIRED, ADDITIONAL TESTING IS REQUIRED.

MY3400



2.2.2 Metric Fastener Torque Chart

Values for Zinc Yellow Chromate Fasteners (Ref 4150707)							
CLASS 8.8 METRIC BOLTS CLASS 8 METRIC NUTS							
Size	PITCH	Tensile Stress Area	Clamp Load	Torque (Dry or Loctite® 263™)	Torque (Lub)	Torque (Loctite® 262™ OR Vibra-TITE™ 131)	Torque (Loctite® 242™ or 271™ OR Vibra-TITE™ 111 or 140)
		Sq mm	KN	[N.m]	[N.m]	[N.m]	[N.m]
3	0.5	5.03	2.19	1.3	1.0	1.2	1.4
3.5	0.6	6.78	2.95	2.1	1.6	1.9	2.3
4	0.7	8.78	3.82	3.1	2.3	2.8	3.4
5	0.8	14.20	6.18	6.2	4.6	5.6	6.8
6	1	20.10	8.74	11	7.9	9.4	12
7	1	28.90	12.6	18	13	16	19
8	1.25	36.60	15.9	26	19	23	28
10	1.5	58.00	25.2	50	38	45	55
12	1.75	84.30	36.7	88	66	79	97
14	2	115	50.0	140	105	126	154
16	2	157	68.3	219	164	197	241
18	2.5	192	83.5	301	226	271	331
20	2.5	245	106.5	426	320	383	469
22	2.5	303	132.0	581	436	523	639
24	3	353	153.5	737	553	663	811
27	3	459	199.5	1080	810	970	1130
30	3.5	561	244.0	1460	1100	1320	1530
33	3.5	694	302.0	1990	1490	1790	2090
36	4	817	355.5	2560	1920	2300	2690
42	4.5	1120	487.0	4090	3070	3680	4290

NO. 5000059 REV. J

- NOTES: 1. THESE TORQUE VALUES DO NOT APPLY TO CADMIUM PLATED FASTENERS
 2. ALL TORQUE VALUES ARE STATIC TORQUE MEASURED PER STANDARD AUDIT METHODS TOLERANCE = ±10%
 *3. ASSEMBLY USES HARDENED WASHER OR FASTENER IS PLACED AGAINST PLATED STEEL OR RAW ALUMINUM
 4. CLAMP LOAD LISTED FOR SHCS IS SAME AS GRADE 8 OR CLASS 10.9 AND DOES NOT REPRESENT FULL STRENGTH CAPABILITY OF SHCS. IF HIGHER LOAD IS REQUIRED, ADDITIONAL TESTING IS REQUIRED.

MY3171



General Information and Specifications

2.2.2 Metric Fastener Torque Chart (Continued)

Values for Zinc Yellow Chromate Fasteners (Ref 4150707)						
CLASS 10.9 METRIC BOLTS CLASS 10 METRIC NUTS CLASS 12.9 SOCKET HEAD CAP SCREWS M3 - M5*						
Size	PITCH	Tensile Stress Area	Clamp Load	Torque (Dry or Loctite® 263™) K = 0.20	Torque (Lub OR Loctite® 242™ or 271™ OR Vibra-TITE™ 111 or 140) K= 0.18	Torque (Loctite® 262™ OR Vibra-TITE™ 131) K=0.15
		Sq mm	KN	[N.m]	[N.m]	[N.m]
3	0.5	5.03	3.13			
3.5	0.6	6.78	4.22			
4	0.7	8.78	5.47			
5	0.8	14.20	8.85			
6	1	20.10	12.5			
7	1	28.90	18.0	25.2	22.7	18.9
8	1.25	36.60	22.8	36.5	32.8	27.4
10	1.5	58.00	36.1	70	65	55
12	1.75	84.30	52.5	125	115	95
14	2	115	71.6	200	180	150
16	2	157	97.8	315	280	235
18	2.5	192	119.5	430	385	325
20	2.5	245	152.5	610	550	460
22	2.5	303	189.0	830	750	625
24	3	353	222.0	1065	960	800
27	3	459	286.0	1545	1390	1160
30	3.5	561	349.5	2095	1885	1575
33	3.5	694	432.5	2855	2570	2140
36	4	817	509.0	3665	3300	2750
42	4.5	1120	698.0	5865	5275	4395

NO. 500059 REV. J

- NOTES: 1. THESE TORQUE VALUES DO NOT APPLY TO CADMIUM PLATED FASTENERS
 2. ALL TORQUE VALUES ARE STATIC TORQUE MEASURED PER STANDARD AUDIT METHODS TOLERANCE = ±10%
 *3. ASSEMBLY USES HARDENED WASHER OR FASTENER IS PLACED AGAINST PLATED STEEL OR RAW ALUMINUM
 4. CLAMP LOAD LISTED FOR SHCS IS SAME AS GRADE 8 OR CLASS 10.9 AND DOES NOT REPRESENT FULL STRENGTH CAPABILITY OF SHCS. IF HIGHER LOAD IS REQUIRED, ADDITIONAL TESTING IS REQUIRED.

MY3181



**2.2.2 Metric Fastener Torque Chart
(Continued)**

Magni Coating (Ref 4150701)*						
CLASS 12.9 SOCKET HEAD CAP SCREWS M6 AND ABOVE*						
Size	PITCH	Tensile Stress Area	Clamp Load See Note 4	Torque (Dry or Loctite® 263™) K = .17	Torque (Lub OR Loctite® 242™ or 271™ OR Vibra-TITE™ 111 or 140) K = .16	Torque (Loctite® 262™ OR Vibra-TITE™ 131) K = .15
		Sq mm	kN	[N.m]	[N.m]	[N.m]
3	0.5	5.03				
3.5	0.6	6.78				
4	0.7	8.78				
5	0.8	14.20				
6	1	20.10	12.5	13	12	11
7	1	28.90	18.0	21	20	19
8	1.25	36.60	22.8	31	29	27
10	1.5	58.00	36.1	61	58	54
12	1.75	84.30	52.5	105	100	95
14	2	115	71.6	170	160	150
16	2	157	97.8	265	250	235
18	2.5	192	119.5	365	345	325
20	2.5	245	152.5	520	490	460
22	2.5	303	189.0	705	665	625
24	3	353	220.0	900	845	790
27	3	459	286.0	1315	1235	1160
30	3.5	561	349.5	1780	1680	1575
33	3.5	694	432.5	2425	2285	2140
36	4	817	509.0	3115	2930	2750
42	4.5	1120	698.0	4985	4690	4395

NO. 500059 REV. J

- NOTES: 1. THESE TORQUE VALUES DO NOT APPLY TO CADMIUM PLATED FASTENERS
 2. ALL TORQUE VALUES ARE STATIC TORQUE MEASURED PER STANDARD AUDIT METHODS TOLERANCE = ±10%
 *3. ASSEMBLY USES HARDENED WASHER OR FASTENER IS PLACED AGAINST PLATED STEEL OR RAW ALUMINUM
 4. CLAMP LOAD LISTED FOR SHCS IS SAME AS GRADE 8 OR CLASS 10.9 AND DOES NOT REPRESENT FULL STRENGTH CAPABILITY OF SHCS. IF HIGHER LOAD IS REQUIRED, ADDITIONAL TESTING IS REQUIRED.

MY3191



General Information and Specifications

2.2.3 Hydraulic Hose Torque Chart

O-Ring Face Seal & JIC Torque Chart

Size	ORFS	JIC	Flats Method
4	13 lb-ft (18 Nm)	13 lb-ft (18 Nm)	1.5 to 1.75
6	23 lb-ft (31 Nm)	23 lb-ft (31 Nm)	1 to 1.5
8	40 lb-ft (54 Nm)	40 lb-ft (54 Nm)	1.5 to 1.75
10	60 lb-ft (81 Nm)	60 lb-ft (81 Nm)	1.5 to 1.75
12	74 lb-ft (100 Nm)	85 lb-ft (115 Nm)	1.0 to 1.5
16	115 lb-ft (156 Nm)	115 lb-ft (156 Nm)	0.75 to 1.0
20	170 lb-ft (230 Nm)	170 lb-ft (230 Nm)	0.75 to 1.0
24	200 lb-ft (271 Nm)	200 lb-ft (271 Nm)	0.75 to 1.0
32	N/A	270 lb-ft (366 Nm)	0.75 to 1.0

Note: By definition the “Flats Method” will contain some variance. Use the “Flats Method” only when accessibility with a torque wrench is not possible.

Torque Wrench:

1. Identify the appropriate application and refer to the above chart for the correct torque value.
2. If equipped, lubricate o-ring with hydraulic oil. Hand tighten the swivel nut until no lateral movement of the swivel nut can be detected. Average hand torque is 3 lb-ft (4 Nm).
3. Use the double wrench method while tightening to avoid hose twist.
4. Torque wrench must be held at the center of the grip. Apply constant force until it clicks.
5. After the connection has been properly tightened, mark a straight line across the connecting parts indicating that the connection has been properly tightened.

Flats Method:

1. If equipped, lubricate o-ring with hydraulic oil. Hand tighten the swivel nut until no lateral movement of the swivel nut can be detected. Average hand torque is 3 lb-ft (4 Nm).
2. Mark a dot on one of the swivel nut flats and another dot in line on the hex of the adapter it's connecting to.
3. Use the double wrench method while tightening to avoid hose twist.
4. After the connection has been properly tightened, mark a straight line across the connecting parts, not covering the dots indicating that the connection has been properly tightened.



2.3 SPECIFICATIONS

2.3.1 Travel Speeds

	TL642	TL943
First Gear	3.4 mph (5,5 km/h)	2.9 mph (4,7 km/h)
Second Gear	6.1 mph (9,7 km/h)	5.2 mph (8,4 km/h)
Third Gear	13.7 mph (22,0 km/h)	11.4 mph (18,3 km/h)
Fourth Gear	20.4 mph (32,8 km/h)	17.5 mph (28,2 km/h)

2.3.2 Hydraulic Cylinder Performance

Note: Machine with no attachment or load, engine at full throttle, hydraulic oil above 130° F (54° C) minimum, engine at operating temperature.

FUNCTION	APPROXIMATE TIMES (seconds)	
	TL642	TL943
Boom Extend (Boom Level)	14.0	13.6
Boom Retract	12.3	15.8
Boom Lift	12.6	10.7
Boom Lower	9.2	7.8
Attachment Tilt Forward	3.4	4.6
Attachment Tilt Rearward	3.9	4.5
Frame Level - Full Right to Left	6.3	10.2
Frame Level - Full Left to Right	8.6	11.8

2.3.3 Cylinder Drift

CYLINDER	MAXIMUM ROD TRAVEL (loaded or unloaded)
Lift/Lower Cylinder	0.125 in (3.2 mm) per hour
Extend/Retract Cylinder	0.125 in (3.2 mm) per hour
Attachment Tilt Cylinder	0.125 in (3.2 mm) per hour



General Information and Specifications

2.3.4 Electrical System

Battery	
Type, Rating	12 BCI, Negative (-) Ground, Maintenance Free
Quantity	1
Reserve Capacity	1000 Cold Cranking Amps @ 0° F (-18° C)
Group/Series	Group 31
Alternator (with Optional A/C)	12V, 65 Amps (12V, 105 Amps)
Alternator (Tier III)	12V, 100 Amps

2.3.5 Engine Performance Specifications

Note: Engine manufacturer's maximum "high idle" setting is lockwired and sealed. **DO NOT** disturb this setting

Description	TL642 & TL943 (Before S/N TBK01167 excluding TBK01162; Before S/N TBL01599 excluding TBL01551 & TBL01585)	TL642 & TL943 (S/N TBK01167 & After including TBK01162; S/N TBL01599 & After including TBL01551 & TBL01585)
	Engine Make/Model	CAT 3054C
Displacement	269 in ³ (4,4 liters)	269 in ³ (4,4 liters)
Low Idle	800 to 850 rpm	1000 rpm
High Idle	2475 to 2525 rpm	2435 to 2485 rpm
Horsepower	99 HP (74 kW) @ 2400 rpm	99 HP (74 kW) @ 2400 rpm
Peak Torque	274 lb-ft (371 Nm) @ 1400 rpm	310 lb-ft (420 Nm) @ 1400 rpm
Fuel Delivery	Fuel Injection	
Air Cleaner	Dry Type, Replaceable Primary and Safety Elements	



2.3.6 Tires

Note: Standard wheel lug nut torque is 350-400 lb-ft (475-542 Nm).

Note: Pressure for foam filled tires are for initial fill ONLY.

Size	Tire Type	Minimum Ply/ Star Rating	Fill Type	Pressure
13.00 x 24	G2/L2 Bias Ply Traction	12 Ply	Pneumatic	65 psi (4,5 bar)
			Foam - Approx 542 lb (246 kg)	65 psi (4,5 bar)
13.00 x 24	G3/L3 Bias Ply Rock	12 Ply	Pneumatic	65 psi (4,5 bar)
			Foam - Approx 542 lb (246 kg)	65 psi (4,5 bar)
13.00 x 24	G2/L-2 Radial	1 Star	Pneumatic	70 psi (4,8 bar)
			Foam - Approx 542 lb (246 kg)	75 psi (5,1 bar)
13.00 x 24			Solid - 799 lb (362,4 kg)	
15.50 x 25	G2/L2 Bias Ply Traction	12 Ply	Pneumatic	58 psi (4,0 bar)
			Foam - Approx 600 lb (272 kg)	58 psi (4,0 bar)
15.50 x 25	G3/L3 Bias Ply Rock	12 Ply	Pneumatic	65 psi (4,5 bar)
			Foam - Approx 600 lb (272 kg)	58 psi (4,0 bar)
15.50 x 25	G2/L2 Radial	1 Star	Pneumatic	70 psi (4,8 bar)
			Foam - Approx 600 lb (272 kg)	73 psi (5,0 bar)
370/75x28	DuraForce	14 Ply	Pneumatic	76 psi (5,2 bar)
			Foam - Approx 464 lb (210 kg)	73 psi (5,0 bar)



2.4 FLUIDS AND LUBRICANT CAPACITIES

a. Fluids

Compartment or System	Type and Classification	Viscosities	Ambient Temperature Range			
			° F		° C	
			Min	Max	Min	Max
Engine Crankcase	Cat DEO Multigrade Cat DEO SYN Cat Arctic DEO SYN Cat ECF-1 API CG-4 Multigrade	SAE 0W-20	-40	50	-40	10
		SAE 0W-30	-40	86	-40	30
		SAE 0W-40	-40	104	-40	40
		SAE 5W-30	-22	86	-30	30
		SAE 5W-40	-22	122	-30	50
		SAE 10W-30	0	104	-18	40
		SAE 10W-40	0	122	-18	40
		SAE 15W-40	15	122	-9.5	50
Transmission and Transfer Case	Cat MTO		-10	104	-23	40
	Dextron or Mercron ATF		-40	14	-42	-1
Axle Differential* and Wheel End	Cat Synthetic Gear Oil (GO)	SAE 75W-140	-22	113	-30	45
	Cat Gear Oil (GO)	SAE 80W-90	-10	120	-23	49
	Cat Gear Oil (GO)	SAE 85W-140	10	120	-12	59
	Cat TDTO-TMS	Cat TDTO-TMS	-4	122	-20	50
Hydraulic System	Cat TDTO Cat TDTO-TMS Cat Arctic TDTO SYN Commercial TO-4	SAE 0W-20	-40	104	-40	40
		SAE 0W-30	-40	104	-40	40
		SAE 5W-30	-22	104	-30	40
		SAE 5W-40	-22	104	-30	40
		SAE 10W	-4	104	-20	40
		SAE 30	50	122	10	50
		SAE 10W-30	-4	104	-20	40
		SAE 15W-40	5	122	-15	50
		Cat TDTO-TMS	-4	122	-20	50
Boom Wear Pad Grease	Cat Advanced 3Moly	NLGI Grade 2	-4	104	-20	40
Cylinder and Axle Grease	Cat Multipurpose	NLGI Grade 2	-22	104	-30	40



Compartment or System	Type and Classification	Viscosities	Ambient Temperature Range			
			° F		° C	
			Min	Max	Min	Max
Engine Coolant	Cat Extended Life Coolant (ELC)	50/50 Mix	Standard			
		60/40 Mix	Cold Weather			
Fuel	#2 Diesel	Low Sulfur	Standard			
	Blend of #1 diesel and #2 diesel fuels ("winterized" #2)		Cold Weather			
Air Conditioning	Refrigerant R-134a	Tetrafluorethane				

Note: Friction Modifier (CAT Brake Oil Additive) required for axle differentials, see Section b, "Capacities".

b. Capacities

Engine Crankcase Oil

Capacity w/Filter Change	8 quarts (7,5 liters)
--------------------------	-----------------------

Fuel Tank

Capacity	38 gallons (143,8 liters)
Anti-gel Fluid -40° to 0° F(-40° to -20° C)	16 oz (0.5 liters)

Cooling System

System Capacity	
TL642	
Before S/N TBK01167 excluding TBK01162	22.5 quarts (21,3 liters)
S/N TBK01167 & After including TBK01162	19 quarts (18 liters)
TL943	
Before S/N TBL01599 excluding TBL01551 & TBL01585	18.4 quarts (17,4 liters)
S/N TBL01599 & After including TBL01551 & TBL01585	19 quarts (18 liters)

Hydraulic System

System Capacity	
TL642	
Before S/N TBK01167 excluding TBK01162	43 gallons (163 liters)
S/N TBK01167 & After including TBK01162	47.5 gallons (180 liters)
TL943	
Before S/N TBK01167 excluding TBK01162	40 gallons (151 liters)
S/N TBK01167 & After including TBK01162	47.5 gallons (180 liters)



General Information and Specifications

Hydraulic System (continued)

Reservoir Capacity to Full Mark	
TL642	
Before S/N TBK01167 excluding TBK01162	20 gallons (75,7 liters)
S/N TBK01167 & After including TBK01162	24.5 gallons (92,7 liters)
TL943	
Before S/N TBL01599 excluding TBL01551 & TBL01585	23 gallons (87 liters)
S/N TBL01599 & After including TBL01551 & TBL01585	24.5 gallons (92,7 liters)

Transmission

Capacity with Filter Change	4.2 gallons (16 liters)
-----------------------------	-------------------------

Transfer Case

Capacity	1.7 quarts (1,6 liters)
----------	-------------------------

Axles

Differential Housing Capacity	15 quarts (14,2 liters)
Friction Modifier (differential only)	24 ounces (709 milliliter)
Wheel End Capacity	1.7 quarts (1,65 liters)

Air Conditioning System (if equipped)

System Capacity	2.5 lb (1134 g)
-----------------	-----------------



2.5 SERVICE AND MAINTENANCE SCHEDULES

2.5.1 10, 1st 50 & 50 Hour



EVERY
10

Check Fuel Level	Air Filter Restriction Indicator	Check Engine Oil Level	Check Hydraulic Oil Level	Check Tire Condition & Pressure
Check Transmission Oil Level	Additional Checks - OMM			

1st
50

Check Wheel Lug Nut Torque				
----------------------------	--	--	--	--

EVERY
50

Drain Fuel/Water Separator	Check Engine Coolant Level	Check Battery	Check Washer Fluid Level (if equipped)	Lubrication Schedule
----------------------------	----------------------------	---------------	--	----------------------

OAL2650



General Information and Specifications

2.5.2 1st 250, 250 & 500 Hour



1st
250

Change Axle Oil	Change Wheel End Oil	Change Transmission Oil & Filter	Change Transfer Case Oil

EVERY
250

Change Engine Oil and Filter*	Check Axle Oil Level	Check Wheel End Oil Levels	Air Filter Vacuator Valve	Check Fan Belt
Check Boom Wear Pads	Check Transfer Case Oil Level	Check Rear Axle Stabilization	Lubrication Schedule	

EVERY
500

Change Fuel Filters	Check Wheel Lug Nut Torque

OAL2660





Note: Engine oil and filter service interval can be extended. See Engine Manual for details.



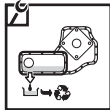
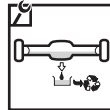
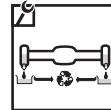

2.5.3 1000 & 1500 Hour



EVERY
1000 

 Change Transmission Oil & Filter	 Change Transfer Case Oil	 Change Axle Oil	 Change Wheel End Oil	 Check Air Intake System
 Check Boom Chains	 Lubrication Schedule			

EVERY
1500 

 Change Engine Coolant	 Change Hydraulic Fluid & Filters	 Change Hydraulic Tank Breather
--	---	---

OAL2670



2.6 LUBRICATION SCHEDULES

a. 50 Hour

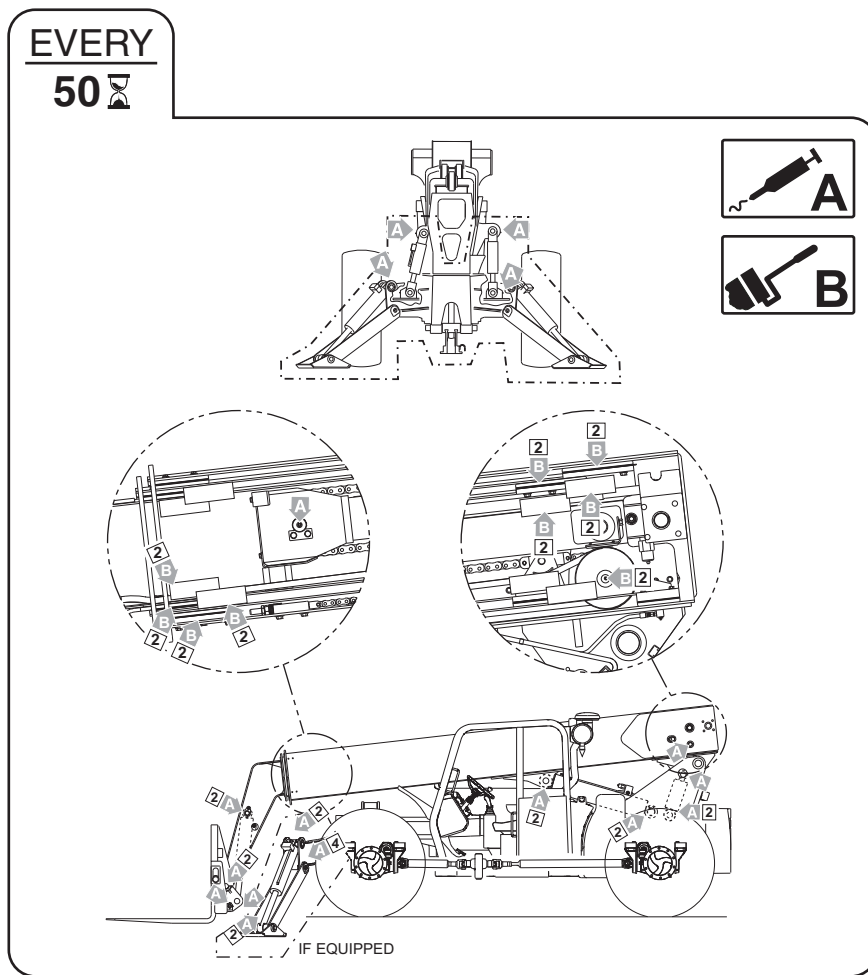



b. 250 Hour

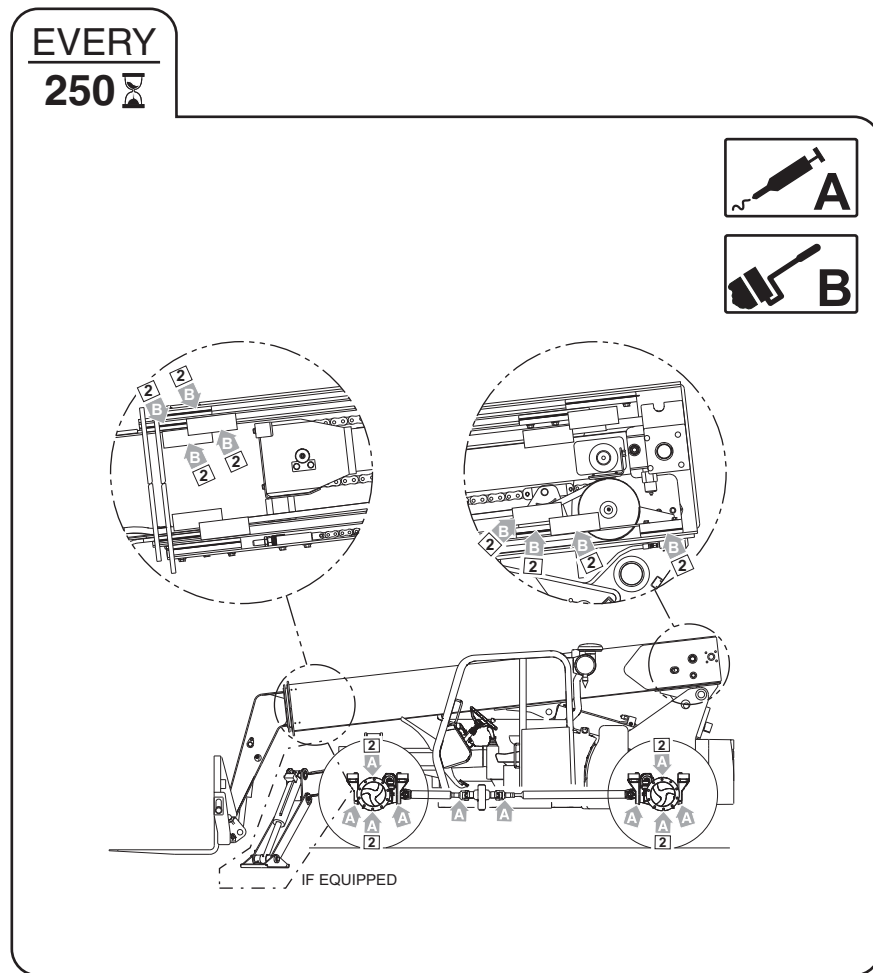



General Information and Specifications

c. 1000 Hour

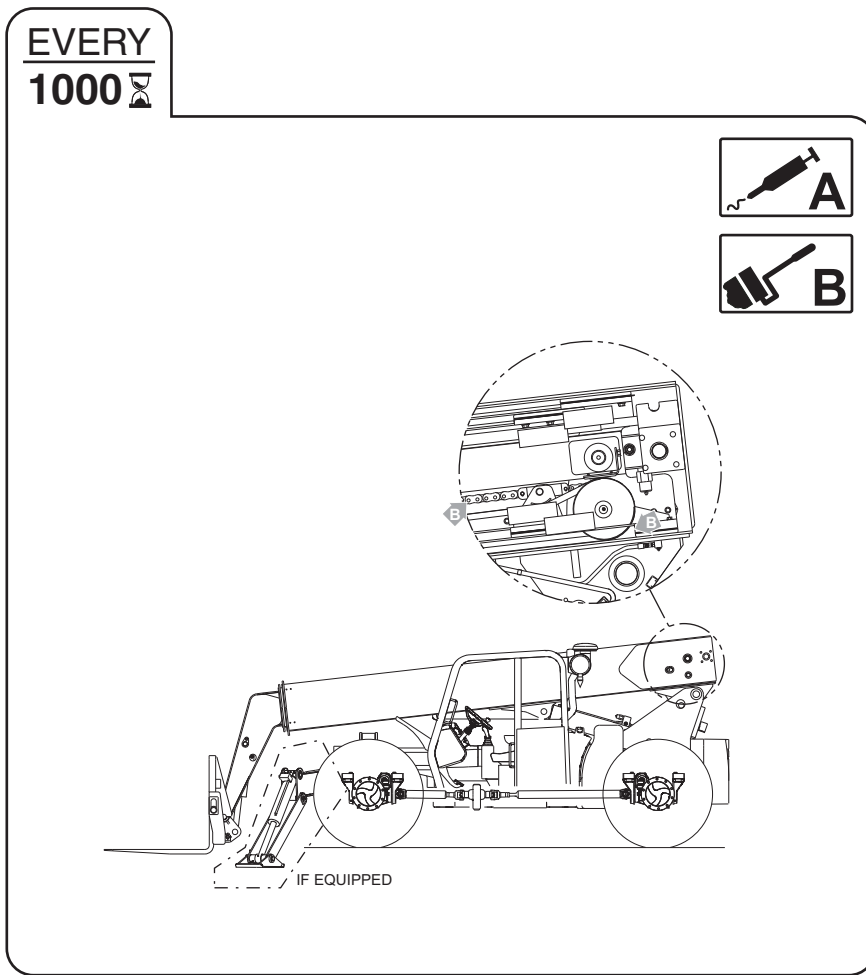

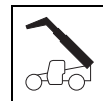

Section 3 Boom

Contents

PARAGRAPH	TITLE	PAGE
3.1	Boom System Component Terminology	3-3
3.2	Boom System - Three Section	3-4
3.2.1	Boom System Operation	3-4
3.3	Boom Assembly Maintenance	3-4
3.4	Complete Boom Removal/Installation	3-5
3.4.1	Complete Boom Removal	3-5
3.4.2	Complete Boom Installation	3-5
3.5	Boom Section Removal/Installation	3-6
3.5.1	Second and Third Boom Section Removal	3-6
3.5.2	Third Boom Section Removal	3-7
3.5.3	Push Beam - Extend/Retract Cylinder Removal	3-8
3.5.4	Push Beam - Extend/Retract Cylinder Installation and Third Boom Section Assembly	3-9
3.5.5	Third Boom Section Installation	3-10
3.5.6	Second and Third Boom Section Installation	3-12
3.6	Extend/Retract Chain Removal/Installation	3-14
3.6.1	Extend/Retract Chain Removal	3-14
3.6.2	Extend/Retract Chain Installation	3-15
3.7	Push Beam - Extend/Retract Cylinder Removal/Installation	3-16
3.7.1	Push Beam - Extend/Retract Cylinder Removal	3-16
3.7.2	Push Beam - Extend/Retract Cylinder Installation	3-18
3.8	Boom Section Separation Adjustment	3-20
3.9	Quick Coupler Assembly	3-20
3.9.1	Quick Coupler Removal	3-20
3.9.2	Quick Coupler Installation	3-20
3.9.3	Connecting with a Mechanical Quick Coupler Device	3-21
3.9.4	Connecting with a Hydraulic Quick Coupler Device	3-21
3.9.5	Connecting with a Quick Coupler to a Hydraulic Operated Attachment	3-22
3.10	Boom Head - Mounted Winch	3-22
3.10.1	Boom Head-Mounted Winch Removal	3-22
3.10.2	Boom Head-Mounted Winch Installation	3-22
3.11	Boom Wear Pads	3-23
3.11.1	Wear Pad Inspection	3-23
3.11.2	Wear Pad Installation and Lubrication	3-23



Boom

3.12	Boom Extend and Retract Chains	3-24
3.12.1	Boom Chain Inspection	3-24
3.12.2	Inspection Guidelines	3-24
3.12.3	Chain Lubrication	3-26
3.13	Forks	3-27
3.14	Troubleshooting	3-28
3.15	Push Beam Temporary Brackets	3-31

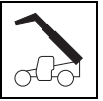

3.1 BOOM SYSTEM COMPONENT TERMINOLOGY

The following illustrations identify the components that are referred to throughout this section.

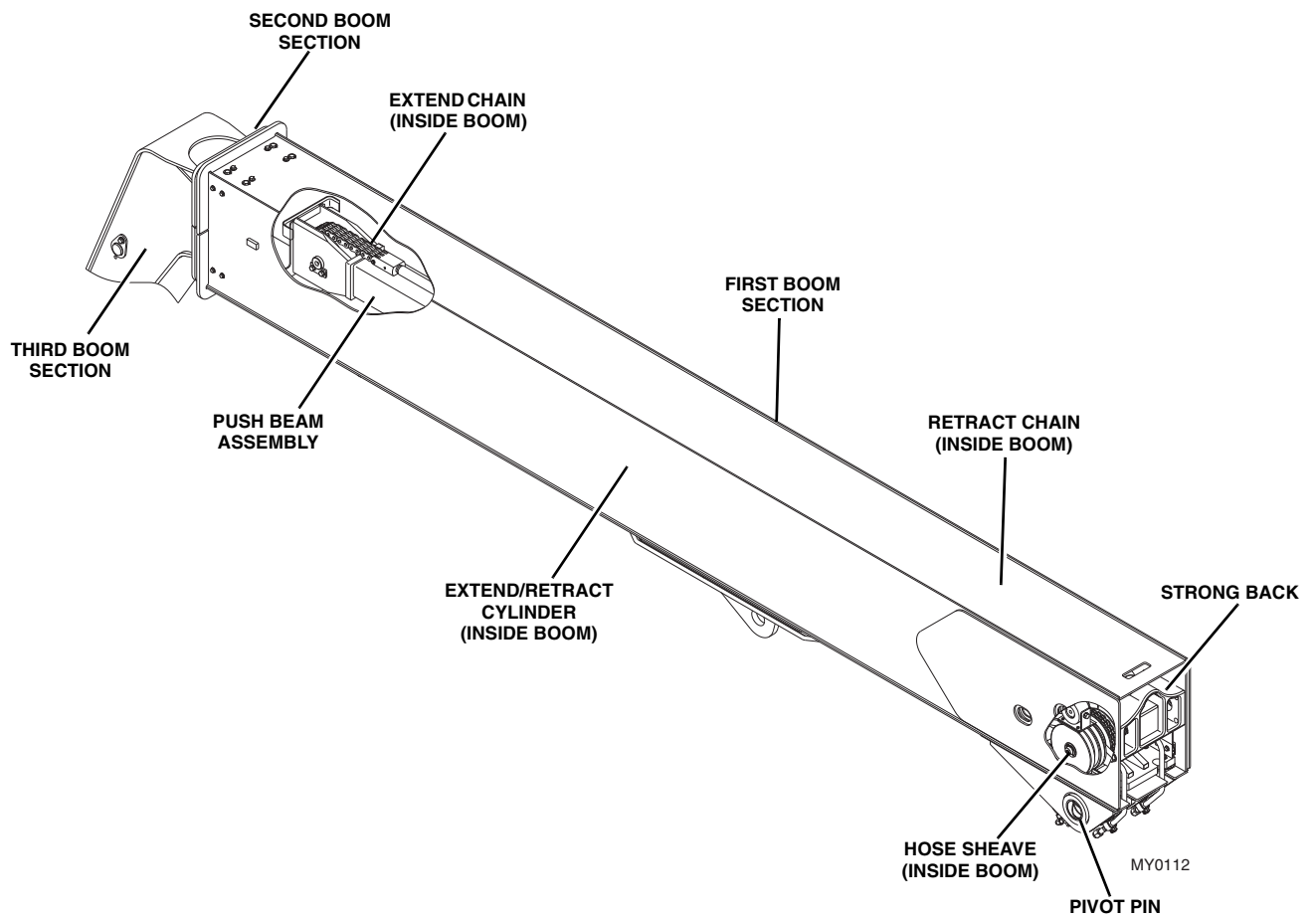



Boom

3.2 BOOM SYSTEM - THREE SECTION

3.2.1 Boom System Operation

The three section boom consists of the first, second and third assemblies with a single extend chain, and a single retract chain.

As the extend/retract cylinder, which is anchored at the rear of the first boom section, and the front of the push beam begins to extend, it forces the second and third boom sections out of the first boom section.

The boom sections are connected by extend and retract chains. These chains are routed around sheaves on the front of the push beam and the rear of the second boom section. As the extend/retract cylinder is forced out hydraulically, the second boom section is pulled out by the push beam, and third boom section is pulled out by the extend chain.

As hydraulic pressure is applied to the retract port on the extend/retract cylinder, the retract chain pulls the third boom section and the push beam pulls the second boom section back into the first boom section.

The mechanical linkage formed by the chains and supporting hardware, extend and retracts the second and third boom sections at the same rate.

The boom section lifts and lowers via action of the lift/lower cylinder.

3.3 BOOM ASSEMBLY MAINTENANCE

These instructions provide the complete boom assembly removal and installation or the second and third boom sections removal and installation.

Before beginning, conduct a visual inspection of the machine and work area, and review the task about to be undertaken. Read, understand and follow these instructions. The boom assembly consists of the first, second and third section booms and supporting hardware.

Note: Before removing the boom or boom section, the carriage or any other attachment must be removed from the quick coupler.

Before beginning, conduct a visual inspection of the machine and work area, and review the task about to be undertaken. Read, understand and follow these instructions.

During service of the boom, perform the following:

1. Check wear pads. (Refer to Section 3.11, "Boom Wear Pads.")
2. Check hose sheaves and chain rollers.
3. Apply grease at all lubrication points (grease fittings). (Refer to Section 2.6, "Lubrication Schedule.")
4. Check for proper operation by operating all boom functions through their full ranges of motion several times.

Note: Depending on your particular circumstance, the following procedures explain the removal/installation of individual boom sections or removal/installation of the complete boom.

WARNING

NEVER weld or drill the boom unless approved in writing by the manufacturer. The structural integrity of the boom will be impaired if subjected to any repair involving welding or drilling.

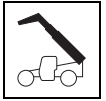

3.4 COMPLETE BOOM REMOVAL/INSTALLATION

3.4.1 Complete Boom Removal

1. Remove any attachment from the quick coupler assembly. Refer to Section 3.9, "Quick Coupler Assembly."
2. Remove the quick coupler assembly. Refer to Section 3.9.1, "Quick Coupler Removal."
3. If equipped, remove the boom head mounted winch. Refer to Section 3.9.5, 3.10. "Boom Head - Mounted Winch."
4. Park the machine on a hard, level surface, level the machine, fully retract the boom, level the boom, place the transmission control lever in (N) NEUTRAL, engage the park brake and shut the engine OFF.
5. Place a Do Not Operate Tag on both the ignition key switch and the steering wheel, stating that the machine should not be operated.
6. Open the engine cover. Allow the system fluids to cool.
7. Properly disconnect the battery.
8. Using a suitable sling or hoist, support the boom.
9. Label, disconnect and cap the hydraulic hoses at the rear of the boom. Cap all fittings to keep dirt & debris from entering the hydraulic system.
10. Label and disconnect any electrical cables (if equipped) at the rear of the boom.
11. Remove the pin from the rod end of the compensation cylinder being careful not to drop the cylinder. Lower the cylinder onto the frame rails.
12. Remove the pin from the rod end of the lift/lower cylinder. Lower the cylinder onto the frame rails.

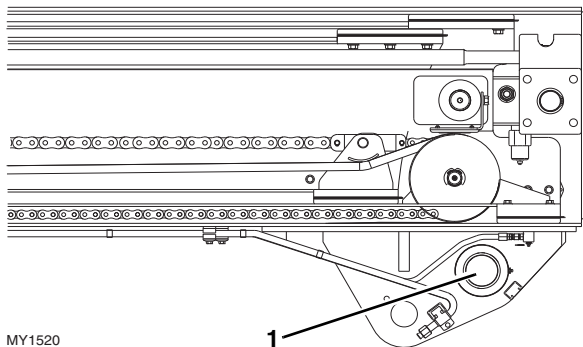

13. Confirm that the boom assembly is balanced with the sling and remove the boom assembly pivot pin (1).

14. Lift the boom assembly from the machine and lower onto suitable supports.

3.4.2 Complete Boom Installation

1. Park the machine on a hard, level surface, place the transmission control lever in (N) NEUTRAL, engage the park brake, chock the wheels and shut the engine OFF.
2. Using suitable slings, balance the boom assembly, lift and carefully guide the boom into place. Align the frame pivot bore with the boom assembly pivot bore. Install the boom pivot pin (1).
3. With the sling still in place, install the compensation cylinder, pins and bolts. Apply Loctite® 242™ and torque lock bolt to 100-110 lb-ft (135-149 Nm).
4. With the sling still in place, install the rod end of the lift/lower cylinder, pin and lock bolt. Apply Loctite® 242™ and torque lock bolt to 200-215 lb-ft (271-291 Nm).

Note: Raising the boom up or down with the sling may be necessary so the boom, compensation and lift/lower cylinder bores can be aligned for easier pin installation.

Note: Grease the boom pivot bore, compensation cylinder rod end, lift/lower cylinder rod end and pins before installing.

5. Uncap and reconnect the previously labeled hydraulic hoses to the extend/retract cylinder.
6. Uncap and connect and remaining hydraulic fittings to their appropriate locations.
7. Recheck wear pad gaps to ensure they meet the minimum gap requirement. Shim if necessary.
8. Ensure that the boom chains are properly adjusted. Refer to Section 3.8, "Boom Section Separation Adjustment."
9. If equipped, install the boom head mounted winch. Refer to Section 3.9.5, 3.10. "Boom Head - Mounted Winch."
10. Properly connect the battery.
11. Install the quick coupler assembly. Refer to Section 3.9.2, "Quick Coupler Installation."
12. Start the engine and operate all boom functions several times. Check for leaks, and check the hydraulic fluid level in the reservoir; add fluid if required.
13. Clean up all debris, hydraulic fluid, etc., in, on, near and around the machine.
14. Close and secure the engine cover.



Boom

15. Remove the Do Not Operate Tags from both the ignition key switch and the steering wheel.
16. Install the previously removed attachment to the quick coupler assembly. Refer to Section 3.9, "Quick Coupler Assembly."

3.5 BOOM SECTION REMOVAL/INSTALLATION

3.5.1 Second and Third Boom Section Removal

Note: Refer to Section 3.12.3, 3.15. "Push Beam Temporary Brackets," for diagrams of the Temporary Extend Bracket and Temporary Retract Bracket designed to hold the chains in place on the push beam during disassembly and reassembly.

These brackets are NOT a purchasable part and must be manufactured locally.

They are solely designed to aid in the removal and installation of the push beam assembly.

Note: Refer to Section 8.8, "Hydraulic Cylinders," for general tilt cylinder removal.

1. Remove the access cover from the rear of the first boom section.

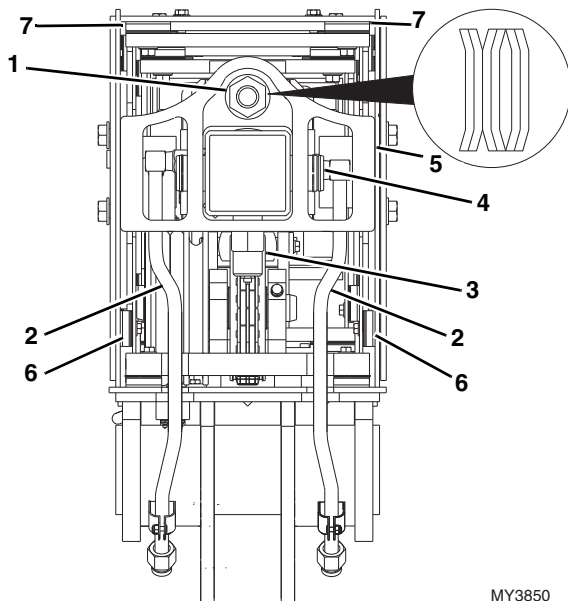

MY3850

2. Remove the locknut, jam nut and six bellville washers (1) from the extend chain clevis rod at the rear of the boom.
3. Loosen and remove both extend/retract cylinder tubes (2) from the rear of the boom. Cap and/or plug

all open hoses, tubes and/or fittings to prevent dirt and debris from entering the hydraulic system.

4. Slowly loosen and remove the extend/retract cylinder counterbalance valve (3). Plug (M27x1.5) the open port on the extend/retract cylinder to prevent dirt and debris from entering the hydraulic system.
5. Remove the retaining clips from the extend/retract cylinder mounting pin (4), remove the extend/retract cylinder pin.
6. Remove the four mounting bolts securing the strong back (5) to the first boom section.
7. Remove the strong back (5) from the rear of the boom.
8. Remove the right or left side wear pads, shims and backing plates (6) from the rear of the second boom section. Label and tag each set of wear pads being removed.
9. Remove the top wear pads, shims and backing plates (7) from the rear of the second boom section. Label and tag each set of wear pads being removed.

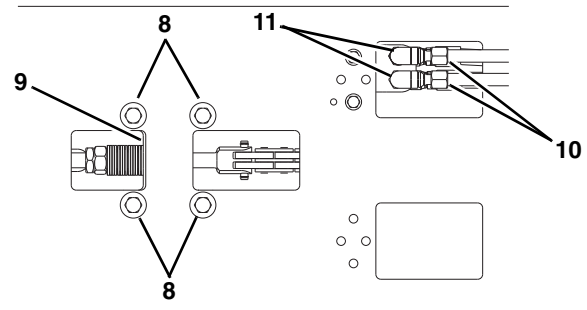

MY3860

10. Loosen and remove the four bolts (8) securing the retract chain anchor plate (9).
11. Between the bottom front of the first and second boom sections, feed a rope or wire to the retract chain anchor plate and secure to the second or third boom section.
12. Disconnect both tilt tubes (10) and (if equipped) both auxiliary tubes from the fittings on the hose retainer brackets (11) at the bottom front inside the boom. Plug the tube ends to prevent dirt and debris from entering the hydraulic system.
13. Disconnect both tilt hoses (not shown) and (if equipped) both auxiliary hoses from the hose retainer brackets at the bottom front inside the boom. Plug the hose ends to prevent dirt and debris from entering the hydraulic system.
14. Loosen and remove the hose retainer brackets (11) and (if equipped) both auxiliary take-up brackets.



15. Between the bottom front of the first and second boom sections, feed a rope or wire to both tilt hoses (not shown) and (if equipped) both auxiliary hoses and secure to the second or third boom section.
16. Place a suitable sling around the second boom section. Slowly pull the second and third boom sections approximately 25% out of the first boom section. Lower the second and third boom sections onto a suitable support.

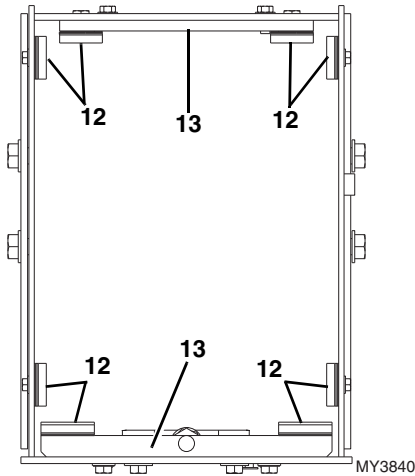

17. Remove all wear pads, shims and backing plates (12) from the front inside of the first boom section. Label and tag each set of wear pads being removed.
18. Remove the top and bottom mounting plates (13) from the front inside of the first boom section. Label and tag each mounting plate being removed.
19. Relocate the sling or using two slings for better stability, balance the two boom sections and slowly pull them out of the first boom section being careful not to damage the hydraulic hoses or chains. Lower the second and third boom sections onto suitable supports.

3.5.2 Third Boom Section Removal

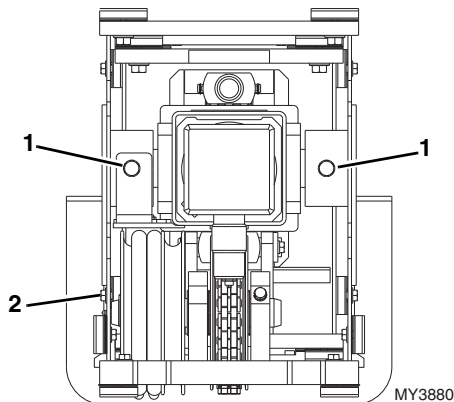

1. Loosen and remove the tilt cylinder hose guide (1) and if equipped, the auxiliary hose guide from the rear of the third second section.

Note: The hose guide mounting bolts also hold the push pin beams in place.

2. Loosen and remove all retract chain sheave components (2) and the hydraulic hose rollers and components.

Note: Offset the extend chain rod to the left or right of the push beam assembly allowing the push beam to be raised enough to allow the removal of the chain and hose sheaves.

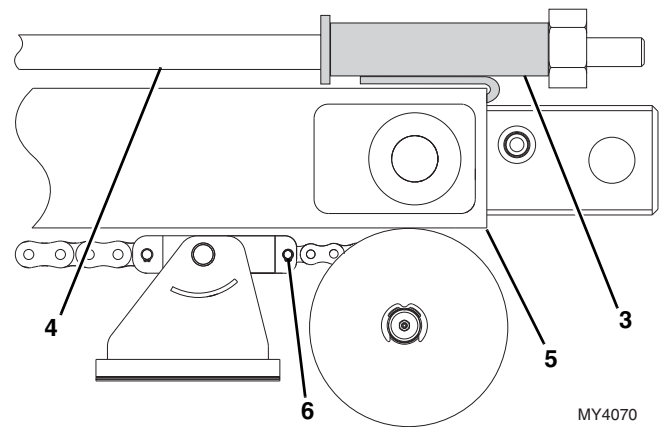

3. Attach the Temporary Extend Chain Retention Bracket (3) between the extend chain rod (4) and the push beam tube (5). Snug in place. Do Not tighten.

Note: Refer to Section 3.15, "Push Beam Temporary Brackets," for Temporary Extend Chain Bracket diagram.

4. At the rear of the boom, remove the retract chain (6) from the chain clevis.

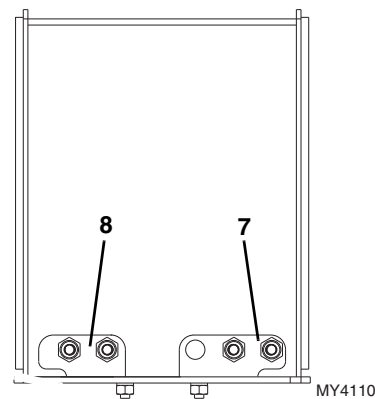

5. Loosen and remove the tilt hoses and (if equipped) auxiliary hoses from the hose retainers (7 & 8) at the front of the third boom section.



Boom

- Loosen and remove the tilt hose and auxiliary hose retainers (7 & 8) from the front of the third boom section.

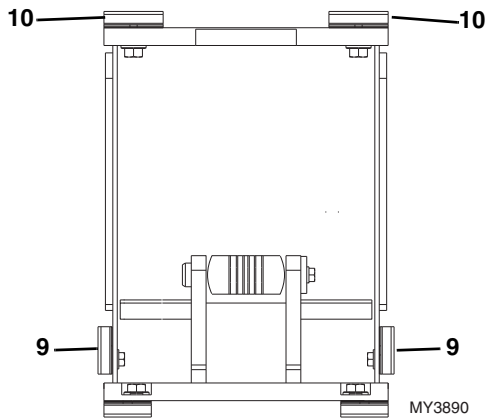

- Remove the right or left side wear pads, shims and backing plates (9) from the rear of the third boom section. Label and tag each set of wear pads being removed.
- Remove the top wear pads, shims and backing plates (10) from the rear of the third boom section. Label and tag each set of wear pads being removed.
- Place a suitable sling around the third boom section. Slowly pull the third boom section approximately 25% out of the second boom section. Lower the third boom section onto a suitable support.

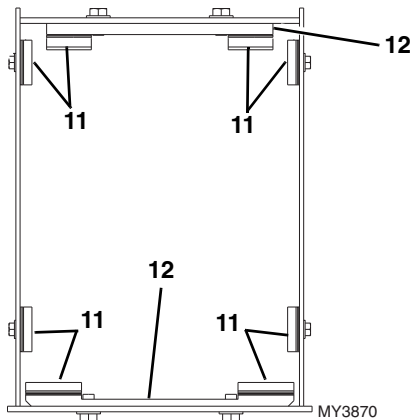

- Remove all wear pads, shims and backing plates (11) from the front inside of the second boom section. Label and tag each set of wear pads being removed.
- Remove wear pad mounting plates (12) from the front inside of the second boom section.

- Relocate the sling or using two slings for better stability, balance the third boom section and slowly pull the third boom section out of the second boom section. Lower the third boom section onto suitable supports.

3.5.3 Push Beam - Extend/Retract Cylinder Removal

CAUTION

The complete push beam assembly weighs over 1,200 lb (545 kg).

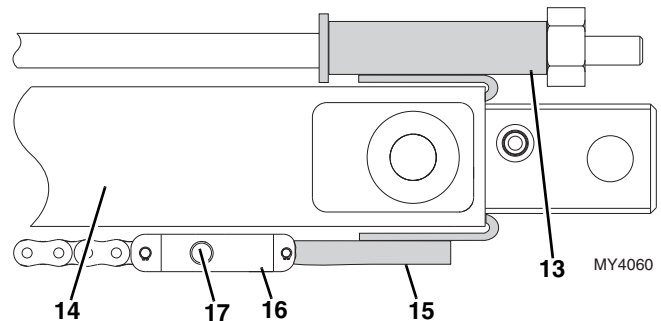

- Loosen the Temporary Extend Chain Retention Bracket (13) and push the push beam (14) forward 3-4 in (76,2-101,6 mm).
- Attach the Temporary Extend Chain Retention Bracket (15) between the chain clevis (16) and the end of the push beam (14).

Note: Refer to Section 3.15, "Push Beam Temporary Brackets," for Temporary Extend Chain Bracket diagram.

- Lift the push beam (14) to unload the clevis pin (17) and remove the pin securing the clevis to the third boom section.
- Tighten the Temporary Extend Chain Retention Bracket (13) to remove any slack in the extend chain.
- Secure a rope or wire to the front of the push beam and pull the push beam (14) towards the front of the boom.
- Support the push beam assembly with pry bars using the access holes on each side of the third boom section.

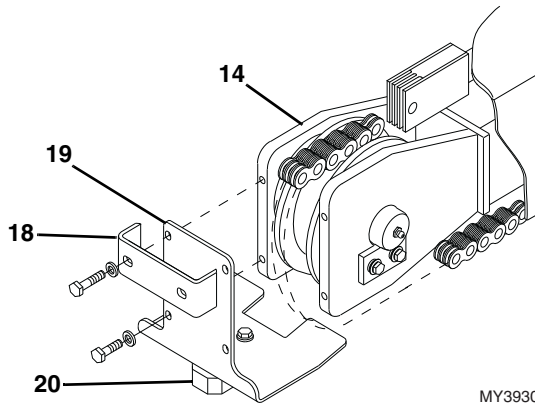
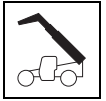

MY3930

7. Remove the guide bar (18) and chain retainer (19). Remove the push beam wear pad (20).
8. Lower the push beam assembly and remove the pry bars.
9. Push/pull the push beam assembly along with the extend chain, to the front of the third boom section.

NOTICE

Guide the push beam/extend/retract cylinder assembly over the top of the retract chain anchor at the rear of the third boom section being careful not to damage any components.

10. Place a sling around the push beam assembly. Lift and slowly pull the push beam assembly approximately half way out of the third boom section. Lower the push beam onto a suitable support.
11. Relocate the sling or using two slings for better stability, balance the push beam assembly and slowly pull the push beam assembly out of the third boom section. Lower the push beam assembly onto suitable supports.
12. Remove all remaining brackets, clevises, hoses, wear pads, shims, backing plates and hardware from the second and third boom sections. Label all parts and hardware being removed from each section.

Note: Inspect all chains, hoses and sheaves for wear and/or damage and replace as needed.

3.5.4 Push Beam - Extend/Retract Cylinder Installation and Third Boom Section Assembly

Note: Inspect the wear pad surfaces of the second and third boom sections. Verify all areas are clean and free of any weld spatter, paint, etc., before beginning the re-assembly procedure.

Note: Inspect and lubricate all extend and retract chains before re-assembly. Refer to Section 3.12, "Boom Extend and Retract Chains," for detailed information.

1. Place the third boom section onto suitable supports.
2. Clean and lubricate the bottom and sides of the third boom section where the push beam guide bar travels.
3. Place a sling or using two slings for better stability, lift and slowly push the push beam assembly approximately half way into the third boom section. Lower the push beam onto a suitable support.
4. Relocate the sling and slowly insert the push beam assembly into the front of the third boom section.

NOTICE

Guide the push beam/extend/retract cylinder assembly over the top of the retract chain anchor at the rear of the third boom section being careful not to damage any components.

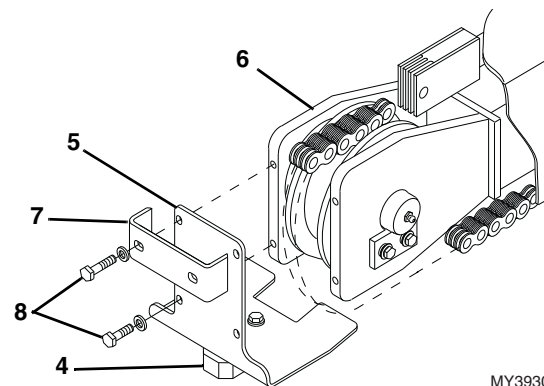

MY3930

5. Install the push beam wear pad (4) to the previously removed chain retainer (5) using two bolts and two washers. Torque as required.
6. Lift the push beam assembly (6) with pry bars using the access holes on each side of the third boom section and install the guide bar (7) and chain retainer (5) using the previously removed hardware (8). Torque to 25-30 lb-ft (34-41 Nm).



Boom

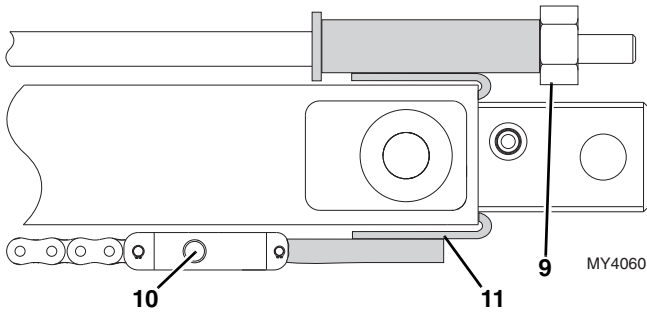

7. Loosen the Temporary Extend Chain Bracket (9).
8. Apply CAT Thread Lubricant to the clevis mounting pin (10).
9. Lift the push beam and install the pin and retaining clips (10) securing the clevis to the third boom section.
10. Remove the Temporary Retract Chain Bracket (11).

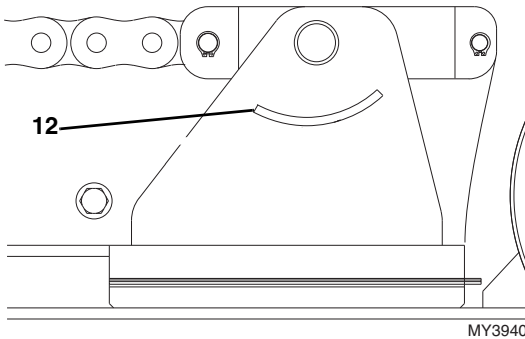

11. Install the tilt cylinder hoses and (if equipped) the auxiliary hoses through the front of the third boom section.

Note: Verify the tilt cylinder hoses and (if equipped) the auxiliary hoses are routed UNDER the hose guide (12) at the rear of the third boom section at the retract chain clevis bracket.

12. Snug the Temporary Extend Chain Bracket (9).

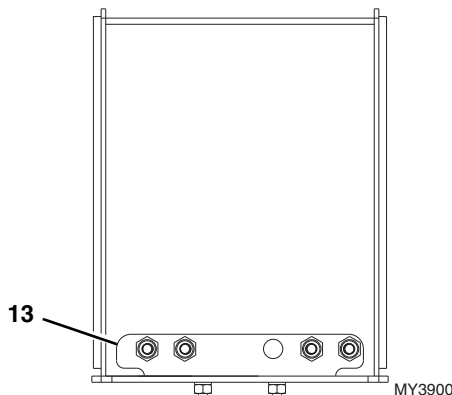

13. Install the hose retainer assembly (13) using existing hardware. Torque as required.
14. Remove caps from the hose retainer fittings and plugs from the tilt cylinder hoses and (if equipped) the auxiliary hoses.
15. Connect the tilt cylinder hoses and (if equipped) the auxiliary hoses to their proper locations. Torque as required.

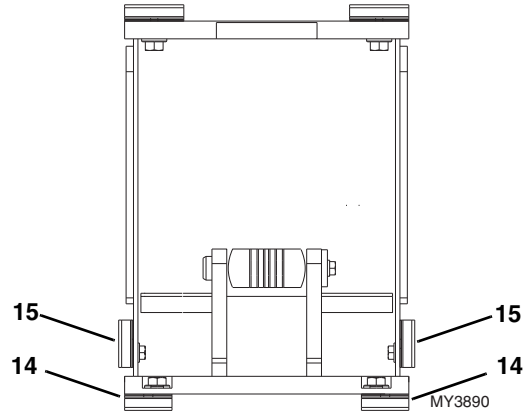

16. Install the previously removed wear pads, shims and spacers (14) at the bottom rear of the third boom section. Snug mounting bolts. Shim as needed AFTER boom section is installed. Refer to Section 3.11.2, "Wear Pad Installation and Lubrication," for detailed information.
17. Install the previously removed wear pad and spacer (15) on the left or right side of the third boom section. Snug mounting bolts. Shim as needed AFTER boom section is installed. Refer to Section 3.11.2, "Wear Pad Installation and Lubrication," for detailed information.

3.5.5 Third Boom Section Installation

Note: Using a straight bar approximately 20 in (508 mm) long will aid in the installation of the wear pads located on the inside front of each boom section.

1. Place the second boom section onto suitable supports.
2. Lubricate the bottom of the third boom section where the wear pads of the second boom section contact the third boom section.
3. Place the sling, or two slings for better stability, around the third boom section and insert the tilt cylinder hoses and if equipped, auxiliary hoses into the second boom section, followed slowly by the third boom section being careful not to damage any surrounding components.

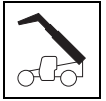

- Lower the third boom section onto a suitable support, relocate one sling and insert the third boom section assembly approximately 75% into the second boom section.

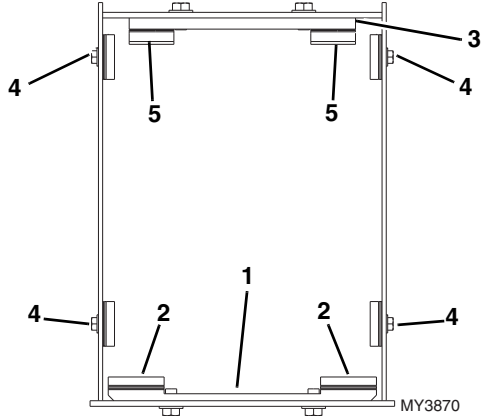

- Install the previously removed wear pad mounting plate (1) with existing hardware at the bottom front of the second boom section. Torque as required
- Install the previously removed wear pads, shims and spacers (2) with existing hardware at the bottom front of the second boom section. Torque as required.
- Install the wear pad mounting plate (3) with existing hardware at the inside top front of the second boom section. Torque as required.
- Install the previously removed wear pads, spacers and shims on each side at the front of the second boom section (4). Snug mounting bolts. Shim as needed AFTER boom section is installed. Refer to Section 3.11.2, "Wear Pad Installation and Lubrication," for detailed information.
- Install wear pads, spacer (5) using bolts and washers at the top front of the second boom section. Snug mounting bolts. Shim as needed AFTER boom section is installed. Refer to Section 3.11.2, "Wear Pad Installation and Lubrication," for detailed information.
- Feed the tilt cylinder hoses and if equipped, auxiliary hoses through the access holes at the rear of the second boom section.
- Push the third boom section the remainder of the way into the second boom section.
- Feed the retract chain through the access holes at the rear of the second boom section.
- Connect the retract chain to the chain clevis at the rear of the second boom section using the existing pin and retaining clips.

- Secure the retract chain, tilt cylinder hoses and if equipped, auxiliary hoses to the bottom of the boom head with rope or wire.

Note: Keep the retract and extend chain free of any dirt and/or contaminants.

- Remove the Temporary Extend Chain Bracket.

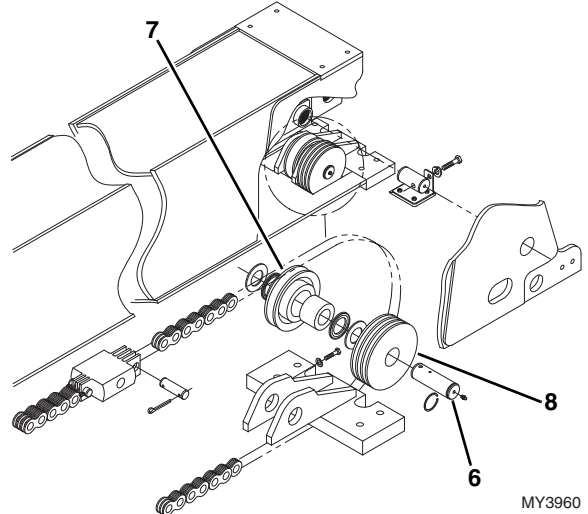

- Install the previously removed pin (6), chain roller (7), tilt hose sheave (8) and if equipped, auxiliary hose sheave assemblies at the rear of the second boom section with existing hardware and shim as required.

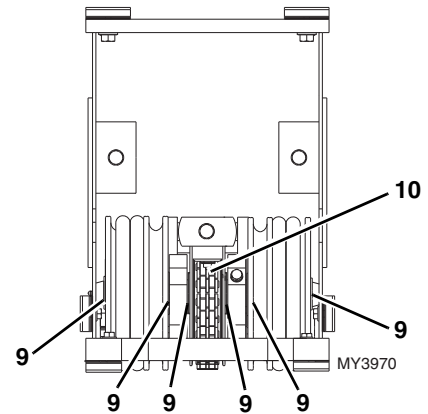

- Thrust washers (9) are to be used as required to shim the hose sheave and retract chain sheave within 0.0625 in (1,6 mm) of a tight fit. At least one thrust washer (9) is required at each noted location.
- Center the retract chain sheave (10) between the mounting plates.
- Feed the tilt cylinder hoses and (if equipped) the auxiliary hoses over and around the hose sheaves.



Boom

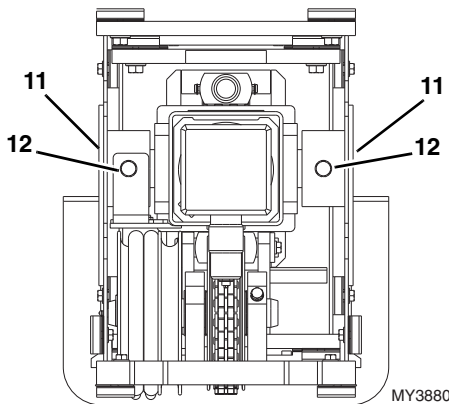

20. Align the push beam bores with the second boom section bores and install the previously removed pins (11).

Note: Verify the cross holes in push beam pins align with holes in each pin bore on the second boom section.

21. Install the previously removed tilt cylinder hose guide (12) and if equipped, the auxiliary hose guide at the rear of the third boom section using the existing hardware. Torque as required.

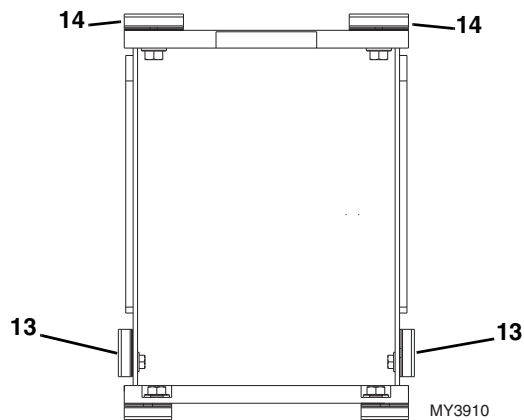

22. Install the previously removed wear pad and spacer (13) on the left or right side of the third boom section. Snug mounting bolts. Shim as needed AFTER boom section is installed. Refer to Section 3.11.2, "Wear Pad Installation and Lubrication," for detailed information.
23. Install the previously removed wear pad and spacer (14) on the top of the third boom section. Snug mounting bolts. Shim as needed AFTER boom section is installed. Refer to Section 3.11.2, "Wear Pad Installation and Lubrication," for detailed information.

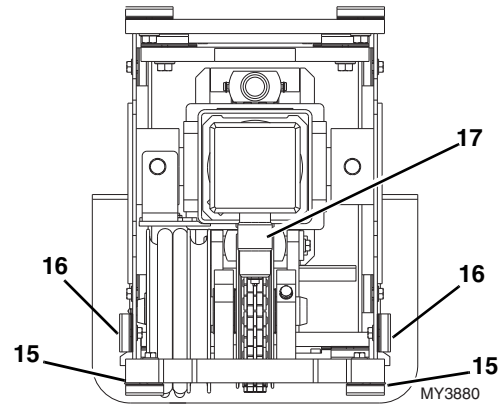

24. Install the previously removed wear pad and spacer (15) on the bottom rear of the second boom section. Snug mounting bolts. Shim as needed AFTER boom section is installed. Refer to Section 3.11.2, "Wear Pad Installation and Lubrication," for detailed information.
25. Install the previously removed wear pad and spacer (16) on the left or right side of the second boom section. Snug mounting bolts. Shim as needed AFTER boom section is installed. Refer to Section 3.11.2, "Wear Pad Installation and Lubrication," for detailed information.
26. Install the previously removed counterbalance valve (17). Torque to 44 lb-ft (59,7 Nm).
27. Torque all wear pad mounting bolts as required.

3.5.6 Second and Third Boom Section Installation

Note: Using a straight bar approximately 20 in (508 mm) long will aid in the installation of the wear pads located on the inside front of each boom section.

1. Lubricate the bottom of the second boom section where the wear pads of the first boom section contact the second boom section.
2. Place the sling, or two slings for better stability, around the third boom section and slowly insert the second and third boom section into the first boom section being careful not to damage hoses, chains and/or surrounding components.
3. Lower the second and third boom section onto a suitable support, relocate one sling and insert the second and third boom section assembly allowing access for the installation of the bottom plate, wear pads, spacers and shims at the front of the first boom section.

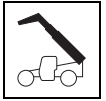

- Remove any rope or wire securing the retract chain and tilt hoses and (if equipped) auxiliary hoses as the second and third boom sections are installed into the first boom section.

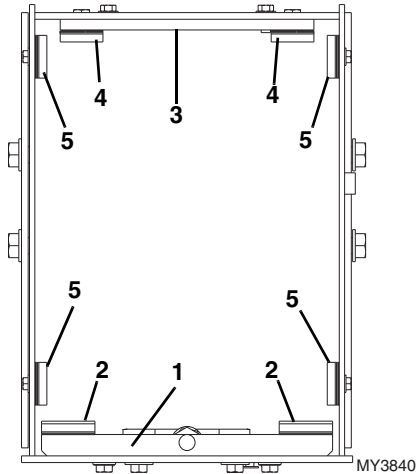

- Install the previously removed mounting plate (1) at the bottom front of the first boom section. Torque as required.
- Install the previously removed wear pads, spacers and shims at the bottom front of the first boom section (2). Snug mounting bolts. Shim as needed AFTER boom section is installed. Refer to Section 3.11.2, "Wear Pad Installation and Lubrication," for detailed information.
- Install the previously removed mounting plate (3) at the top front of the first boom section. Torque as required.
- Install the previously removed wear pads, Spacers (4) P/N 298-1729 and shims at the top front of the first boom section. Snug mounting bolts. Shim as needed AFTER boom section is installed. Refer to Section 3.11.2, "Wear Pad Installation and Lubrication," for detailed information.
- Install the previously removed wear pads, spacers and shims at both sides on the front of the first boom section (5). Snug mounting bolts.

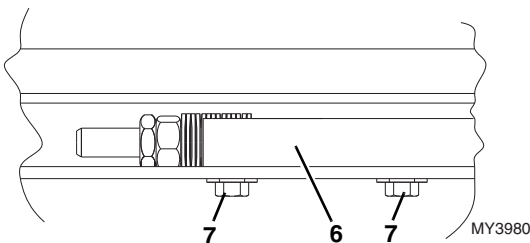

- Install the anchor plate (6) using existing hardware (7) into the first boom section. Torque as required.

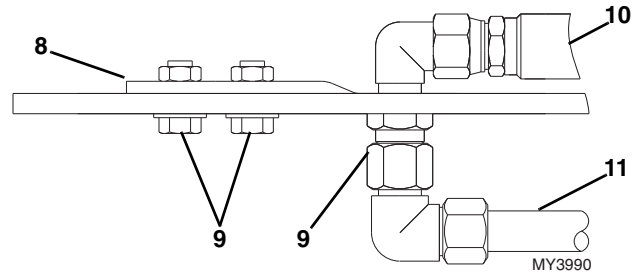

- Install the previously removed tilt hose retainer bracket (8) and (if equipped) both auxiliary hose retainer at the bottom of the first boom section using mounting bolts (9). Torque as required.
- Remove plugs from the previously removed tilt hoses (10) and (if equipped) both auxiliary hoses.
- Connect both tilt hoses (10) and (if equipped) both auxiliary hoses to the fittings on the hose retainer bracket. Torque as required.
- Connect both tilt tubes (11) and (if equipped) both auxiliary tubes to the fittings on the hose retainer bracket. Torque as required.
- Push the second and third boom sections the remainder of the way into the first boom section.

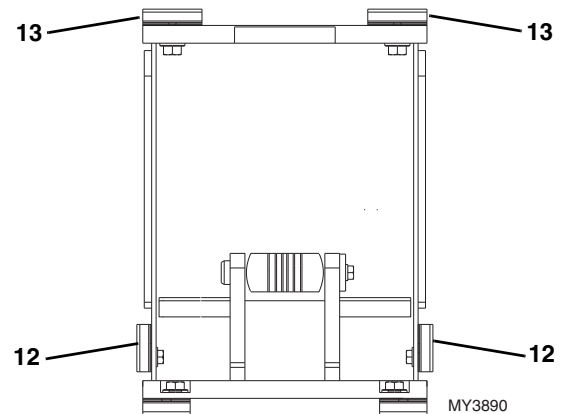

- Install the previously removed wear pad and spacer (12) on the left or right side of the second boom section. Snug mounting bolts. Shim as needed AFTER boom section is installed. Refer to Section 3.11.2, "Wear Pad Installation and Lubrication," for detailed information.
- Install the previously removed wear pad and spacer (13) on the top of the second boom section. Snug mounting bolts. Shim as needed AFTER boom section is installed. Refer to Section 3.11.2, "Wear Pad Installation and Lubrication," for detailed information.



Boom

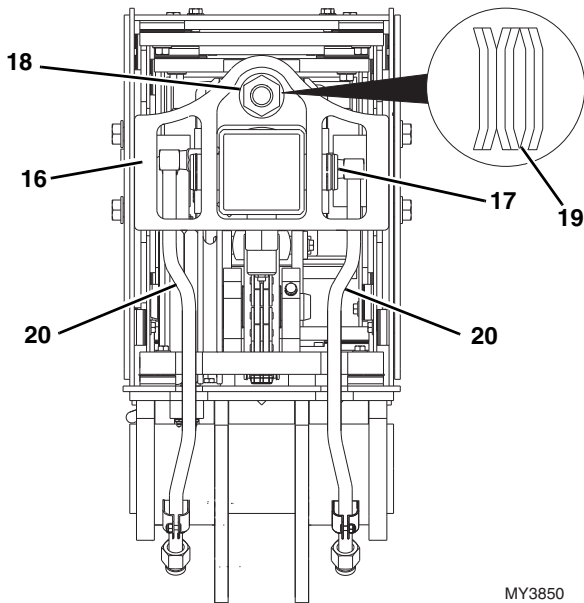

MY3850

18. Install the previously removed strong back (**16**) with the existing hardware. Torque as required.
19. Install the extend/retract cylinder pin (**17**) through the strong back (**16**). Secure the pin with the retaining rings.
20. Apply CAT Thread Lubricant to the extend chain clevis rod threads (**18**).
21. Install the extend chain clevis rod (**18**) into the strong back (**16**).
22. Install the belleville washers (**19**) as previously removed (cupped washer facing strong back). Install the adjusting nut and jam nut. Snug, but Do Not tighten at this time.
23. Remove the caps and plugs from the extend/retract cylinder fittings and the extend/retract tubes (**20**).
24. Install both extend/retract tubes (**20**) and torque as required.
25. Uncap and reconnect the previously labeled hydraulic hoses to the extend/retract cylinder.
26. Uncap and connect and remaining hydraulic fittings to their appropriate locations.
27. Recheck wear pad gaps to ensure they meet the minimum gap requirement. Shim if necessary.
28. Ensure that the boom chains are properly adjusted. Refer to Section 3.8, "Boom Section Separation Adjustment."
29. Properly connect the battery.

30. Start the engine and operate all boom functions several times. Check for leaks, and check the hydraulic fluid level in the reservoir; add fluid if required.
31. Clean up all debris, hydraulic fluid, etc., in, on, near and around the machine.
32. Close and secure the engine cover.
33. Remove the Do Not Operate Tags from both the ignition key switch and the steering wheel.

3.6 EXTEND/RETRACT CHAIN REMOVAL/INSTALLATION

3.6.1 Extend/Retract Chain Removal

The following section explains the removal of the extend/retract chains without removing or disassembling the boom assembly.

1. Park the machine on a hard, level surface, level the machine, fully retract the boom, level the boom, place the transmission control lever in (N) NEUTRAL, engage the park brake and shut the engine OFF.
2. Place a Do Not Operate Tag on both the ignition key switch and the steering wheel, stating that the machine should not be operated.
3. Open the engine cover. Allow the system fluids to cool.
4. Properly disconnect the battery.
5. Remove the cover from the rear of the first boom section.

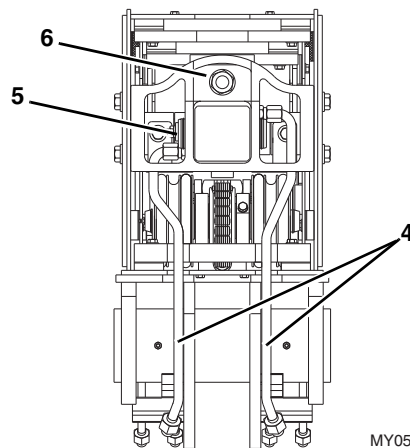

MY0580

6. Remove the extend/retract cylinder hydraulic tubes (**4**). Plug the tube ends and cap the fittings to keep dirt & debris from entering the hydraulic system.



7. Remove the extend/retract cylinder mounting pin (5) from the strong back.
8. Remove the extend chain locknut and jamnut (6) from the strong back.

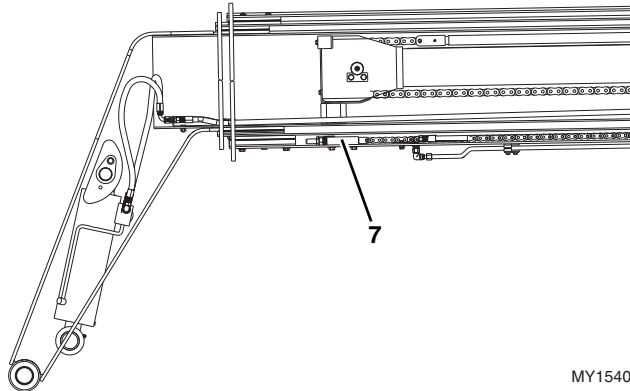

MY1540

9. Remove the retract chain adjustment and jam nuts (7) from the front of the first boom section.
10. Remove the strong back mounting bolts and remove the strong back from the boom.
11. Remove the push beam mounting pins from the rear of the second boom section.
12. Place the chain clevis rod to one side of the push beam.
13. Lift the push beam to gain access to the chain clevis at the rear of the third boom section.
14. Reaching inside the rear of the boom at the chain anchor bracket, remove the cotter pin and pin from the retract chain clevis. Remove the cotter pin and pin from the extend chain.
15. Connect wire or rope (approximately 30 ft (9,1 m) to the end of the extend chain.
16. Lower the push beam. Center the chain clevis rod on the push beam to aid in removal.
17. Pull the push beam/extend chain from the rear of the boom. Disconnect the wire or rope from the extend chain.
18. Pull the retract chain from the rear of the boom.

3.6.2 Extend/Retract Chain Installation

The following section explains the installation of the retract chains without removing the boom assemblies.

Inspect and lubricate chains thoroughly before installation.

1. Push the retract chain through the boom from the rear to the chain adjusting block (7) on the first boom section. Do not tighten the adjusting and jam nut at this time. Thread the nut on the clevis enough to keep the chain in place.
2. Connect the extend chain to the wire or rope at the rear of the boom.
3. Slowly pull the wire or rope guiding the extend chain over the push beam, around the extend chain sheave, under the push beam and stopping at the extend chain/retract chain clevis.
4. Remove the wire or rope secured to the extend chain.
5. Place the chain clevis rod to one side of the push beam.
6. Lift the push beam to gain access to the chain clevis at the rear of the third boom section.
7. Reaching inside the rear of the boom at the chain anchor bracket, install the cotter pin and pin from the extend chain clevis. Install the cotter pin and pin from the retract chain.
8. Lower the push beam. Center the chain clevis rod on the push beam.
9. Place the extend chain rod through the strong back and place the strong back in place at the rear of the first boom section.
10. Install and torque the strong back mounting bolts to 240-265 lb-ft (325-359 Nm).
11. Install the extend/retract cylinder mounting pin and secure with retaining clips.
12. Install the adjusting and jam nuts on the chain clevis rod. Do not tighten at this time.
13. Uncap and connect the extend/retract cylinder hydraulic tubes to their appropriate locations.
14. Adjust the chain as needed. Refer to Section 3.8, "Boom Section Separation Adjustment."
15. Install the cover on the rear of the boom.
16. Properly connect the battery.
17. Close and secure the engine cover.
18. Remove the Do Not Operate Tags from both the ignition key switch and the steering wheel.



Boom

3.7 PUSH BEAM - EXTEND/RETRACT CYLINDER REMOVAL/ INSTALLATION

CAUTION

The complete push beam - extend/retract cylinder assembly weighs over 1,200 lb (545 kg).

The following section explains the removal of the push beam - extend/retract cylinder without removing or disassembling the boom assembly.

3.7.1 Push Beam - Extend/Retract Cylinder Removal

1. Park the machine on a hard, level surface, level the machine, fully retract the boom, level the boom, place the transmission control lever in (N) NEUTRAL, engage the park brake and shut the engine OFF.
2. Place a Do Not Operate Tag on both the ignition key switch and the steering wheel, stating that the machine should not be operated.
3. Open the engine cover. Allow the system fluids to cool.
4. Remove the cover from the rear of the first boom section.

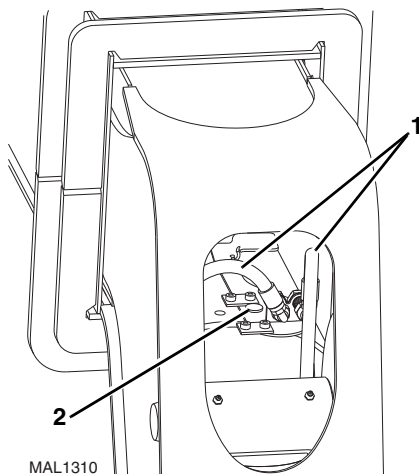

5. Disconnect both tilt hoses (1) and both auxiliary hoses (not shown) from the hose retainer brackets (2) at the bottom front inside the boom. Plug the hose ends to prevent dirt and debris from entering the hydraulic system.
6. Remove both hose retainer brackets (2).

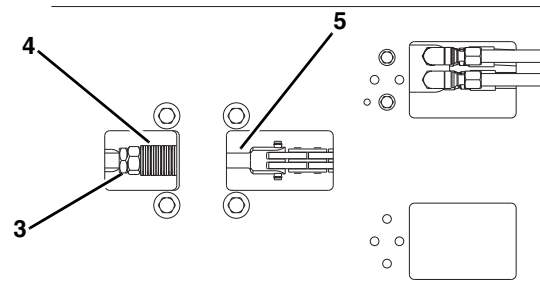

7. Loosen and remove the jamnut, adjusting nut (3) and belleville washers (4) from the retract chain (5) at the bottom front of the first boom section.

Note: Note the position of the belleville washer for reassembly.

8. Secure a rope or wire to the retract chain (5).

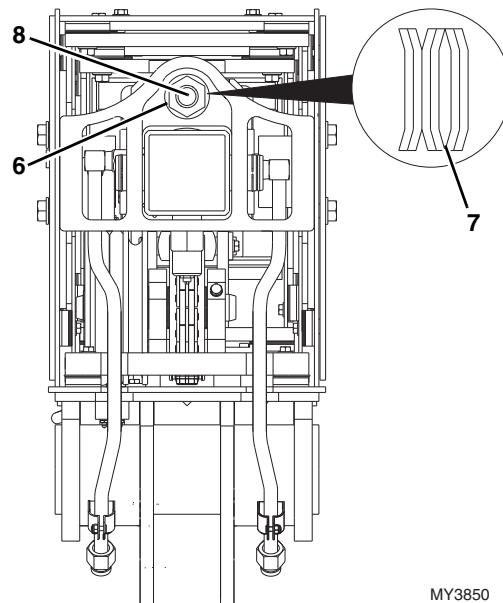

9. Loosen and remove the jamnut, adjusting nut (6) and belleville washers (7) from the extend chain anchor (8) at the rear of the first boom section.

Note: Note the position of the belleville washer for reassembly.

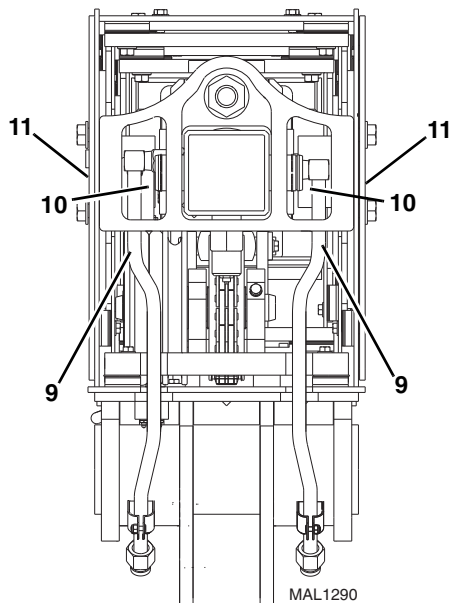

Note: Disconnecting one or both extend/retract hydraulic tubes (9) may be required to gain access to the hose guide mounting bolts. After removing both hose guides, re-connect one or both extend/retract hydraulic tubes BEFORE proceeding.

10. Loosen and remove the tilt cylinder hose guide (10) and if equipped, the auxiliary hose guide from the rear of the third second section.

Note: The hose guide mounting bolts also hold the push pin beams in place.

11. Remove the left and right push beam pins (11).

12. Start the machine and SLOWLY extend the extend/retract cylinder 1 - 2 ft (305 - 609 mm) or until the push beam assembly can be accessed through the front of the third boom section.

Note: Only the push beam - extend/retract cylinder assembly should move during this procedure.

NOTICE

The extend chain rod will move toward the front of boom. Do Not allow the rod to come into contact with the chain and/or chain roller.

13. Shut machine OFF.

14. Properly disconnect the battery.

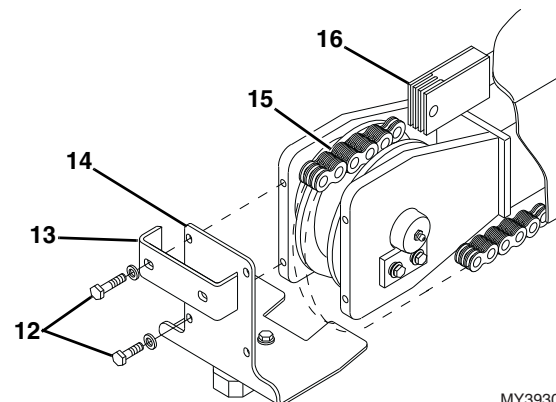

15. Loosen and remove the four bolts (12), guide bar (13) and chain retainer (14) from the front of the push beam.

16. Disconnect the extend chain (15) from the anchor rod (16) and lay flat on the bottom of the third boom section. Remove the anchor rod (16) from the front of the boom.

Note: It may be necessary to lift the extend /retract cylinder through the access holes in the sides of the third boom section to remove the chain retainer (14).

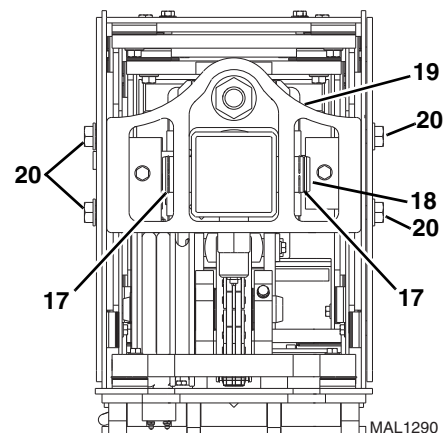

17. At the rear of the boom, remove both retaining clips (17) from the extend/retract cylinder pin (18). Remove the extend/retract cylinder pin from the strong back (19).

18. Loosen and remove the eight bolts (20) from the strong back (19). Remove the strong back.

19. Remove both extend/retract cylinder hydraulic tubes. Plug the tube ends and cap the fittings to prevent dirt and debris from entering the hydraulic system.



Boom

- Place a sling around the push beam - extend/retract cylinder assembly. Lift and slowly pull the push beam - extend/retract cylinder assembly approximately half way out of the boom assembly. Lower the push beam onto a suitable support.

NOTICE

Guide the push beam - extend/retract cylinder assembly over the top of the retract chain anchor at the rear of the third boom section being careful not to damage any components.

- Relocate the sling or using two slings for better stability, balance the push beam - extend/retract cylinder assembly and slowly pull the push beam - extend/retract cylinder assembly out of the boom assembly. Lower the push beam - extend/retract cylinder assembly onto suitable supports.
- Remove the extend/retract cylinder as required.

3.7.2 Push Beam - Extend/Retract Cylinder Installation

- Clean and lubricate the bottom and sides of the third boom section where the push beam guide bar travels.
- Place a sling or using two slings for better stability, lift and slowly push the push beam - extend/retract cylinder assembly approximately half way into the boom assembly. Lower the push beam onto a suitable support.
- Relocate the sling and slowly insert the push beam - extend/retract cylinder assembly into the front of the boom assembly.

NOTICE

Guide the push beam - extend/retract cylinder assembly over the top of the retract chain anchor at the rear of the third boom section being careful not to damage any components.

- Remove the plugs and caps from the extend/retract cylinder hydraulic tubes. Install both extend/retract cylinder hydraulic tubes.

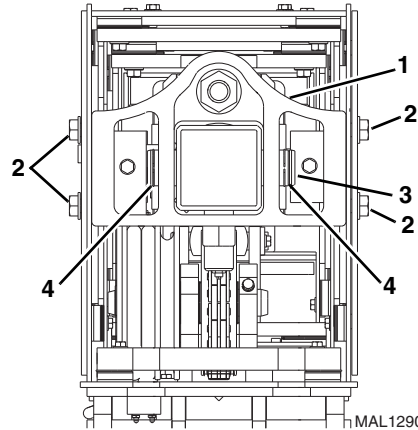

- Install the strong back (1) with the previously removed hardware (2) and torque as required.
- Align the extend/retract cylinder bore with the strong back bores and install the extend/retract cylinder pin (3) and secure with the retaining clips (4).
- Install the anchor rod through the front of the boom assembly.

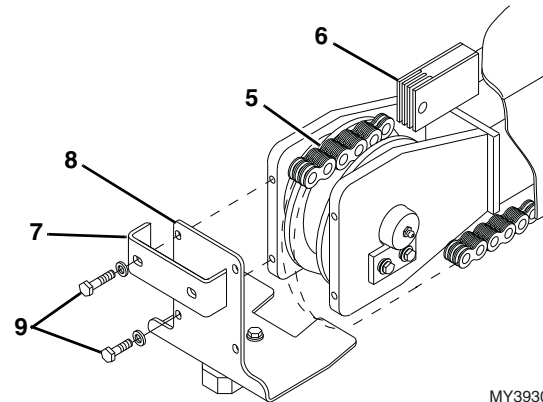

- Connect the extend chain (5) to the anchor rod (6).
- Install the guide bar (7) and chain retainer (8) to the front of the push beam with the previously removed hardware (9).
- Properly connect the battery.
- Start the machine and SLOWLY retract the extend/retract cylinder until the push beam assembly bores can be aligned with boom sections access bores.
- Properly disconnect the battery.

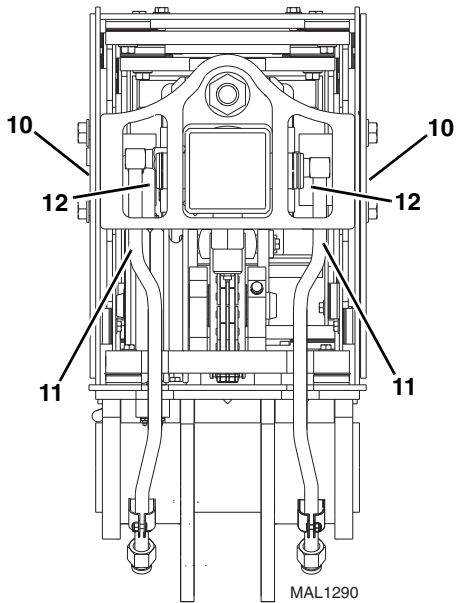
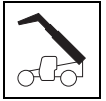

13. Install both push beam pins (10) being careful to align the pin mounting bolt holes.

Note: Disconnecting one or both extend/retract hydraulic tubes (11) may be required to gain access to the hose guide mounting bolts. After installing both hose guides, re-connect one or both extend/retract hydraulic tubes BEFORE proceeding.

14. Install the tilt cylinder hose guide (12) and the auxiliary hose guide from the rear of the third second section.

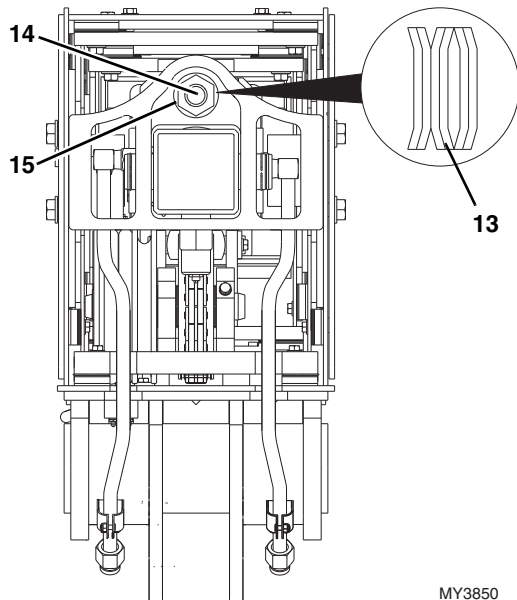

Note: Note the position of the Belleville washers for reassembly.

15. Install the Belleville washers (13) to the extend chain anchor (14) as previously removed at the rear of the first boom section.

16. Install the adjusting and jamnut, (15) to the extend chain anchor (14) at the rear of the first boom section.

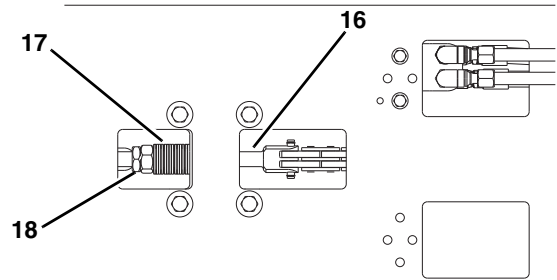

17. Remove the rope or wire from the retract chain (16).

18. Install the Belleville washers (17) to the retract chain clevis (16) as previously removed at the bottom front of the first boom section.

19. Install the adjusting and jamnut (18) to the retract chain clevis (16) at the bottom front of the first boom section.

Note: Note the position of the Belleville washer for reassembly.

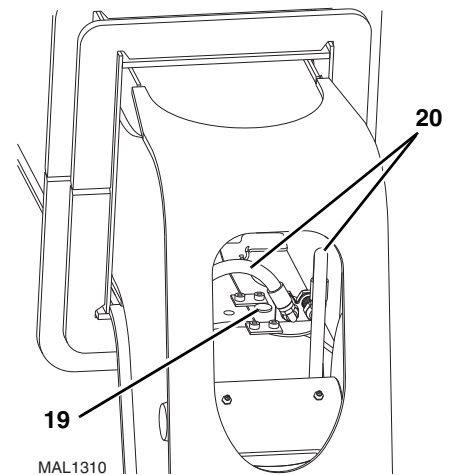

20. Install both hose retainer brackets (19).

21. Remove the plugs and caps from the tilt hoses and auxiliary hoses.

22. Connect both tilt hoses (20) and both auxiliary hoses (not shown) to the hose retainer brackets (19) at the bottom front inside the boom.

23. Properly connect the battery.



Boom

24. Adjust the chain as needed. Refer to Section 3.8, "Boom Section Separation Adjustment."
25. Install the cover on the rear of the boom.
26. Close and secure the engine cover.
27. Remove the Do Not Operate Tags from both the ignition key switch and the steering wheel.

3.8 BOOM SECTION SEPARATION ADJUSTMENT

1. Park the machine on level ground. Place the transmission control lever in (N) NEUTRAL, engage the parking brake switch and level the boom.
2. Extend the boom 4 to 5 ft (1,2 to 1,5 m), then fully retract the boom.

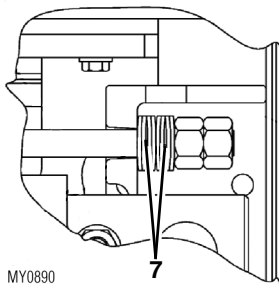

MY0890

3. Measure the gap (7) on the belleville washer on the extend chain rod. If the total of all gaps exceeds 0.12 in (3,04 mm), the boom chains will need to be adjusted.

While doing the chain inspection, check all chain clevis ends for distortion or cracking and sheaves for bearing wear or grooving from the chain.

If during the inspection, any chain is found to be damaged or stretched, the chain must be replaced. It is recommended that when any chain is replaced, that all the chains and clevises be replaced at the same time.

Adjust the extend chain as follows:

1. Loosen the lock nut on the extend chain rod.
2. Tighten the adjusting nut on the extend chain rod until all washers are flat (no gap between any washers).
3. Torque the lock nut to 100 lb-ft (135 Nm).
4. After adjusting, check to see that the boom sections and access holes are aligned. If they are not, the retract chain will need to be adjusted as well.

Adjust the retract chain as follows:

1. Fully retract the boom.
2. Measure the distance between the second boom section and the third boom section.

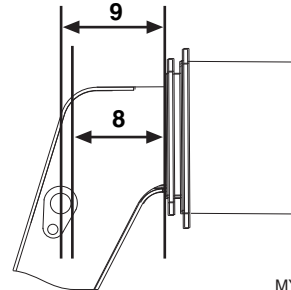

MY0880

- The dimension (8) (should be 11.625 in \pm 0.625 in (295,3 mm \pm 16 mm) for the TL642 measured from the back edge of the tilt cylinder pin and the second boom section.
 - The dimension (9) should be 18.132 in \pm 0.125 in (460,55 mm \pm 3 mm) for the TL943 measured from the center of the tilt cylinder pin and the second boom section.
3. Loosen the extend chain lock nut and adjusting nut as far as possible.
 4. Tighten the retract chain adjusting nut until the proper distance is obtained and proper access hole alignment is obtained.
 5. Torque the lock nut to 100 lb-ft (135 Nm).
 6. Re-adjust the extend chain as needed.

3.9 QUICK COUPLER ASSEMBLY

3.9.1 Quick Coupler Removal

1. Remove the lock bolt holding the tilt cylinder rod end pin to the quick coupler assembly. Remove the Tilt Cylinder pin.
2. Support the quick coupler assembly. Remove the capscrew and locknut securing the head pin to the boom head.
3. Inspect the above pins for nicks or surface corrosion. Use fine emery cloth to fix minor nicks or corrosion. If damaged or if it cannot be repaired the pin must be replaced.

3.9.2 Quick Coupler Installation

1. Assemble the quick coupler to the boom head. Line up the quick coupler between the mounts on the boom head. The quick coupler should be centered in the boom head.

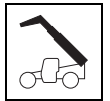

2. Coat the quick coupler head pin with an anti-seize compound. Insert the quick coupler head pin through the quick coupler and boom head. Secure with the previous capscrew and locknut.
3. Align the quick coupler with the tilt cylinder rod end and insert the tilt cylinder pin. Align the tilt cylinder pin and screw in the locking bolt. Torque as required.

3.9.3 Connecting with a Mechanical Quick Coupler Device

This machine is equipped with a quick coupler assembly system for easy attachment changes.

1. Tilt the quick coupler device forward to provide clearance. Check to be sure lock pin and retainer pin are out.

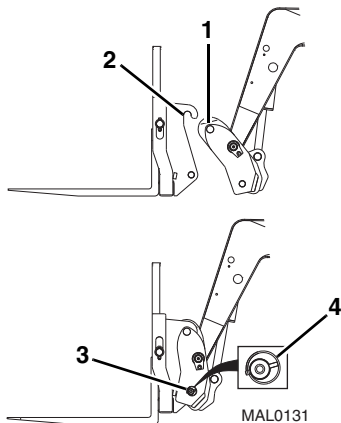

2. Align attachment pin (1) with recess in attachment (2). Raise boom slightly to engage attachment pin in recess.
3. Tilt quick coupler device back to engage attachment.
4. Shut off engine. Exit cab and insert lock pin (3) and secure with retainer pin (4).
5. If equipped, connect the attachment hydraulic hoses to the boom head auxiliary connections. Refer to Section 3.9.5, "Connecting with a Quick Coupler to a Hydraulic Operated Attachment."

3.9.4 Connecting with a Hydraulic Quick Coupler Device

1. Tilt the quick coupler device to provide clearance. Check to be sure lock pin is disengaged.

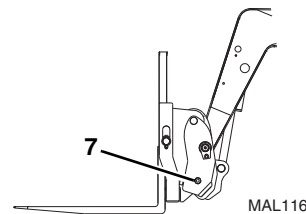
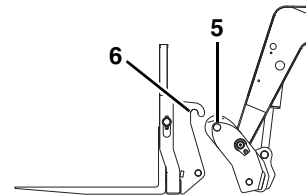

2. Align attachment pin (5) with recess in attachment (6). Raise boom slightly to engage attachment pin in recess.
3. Tilt quick coupler device back to engage attachment.

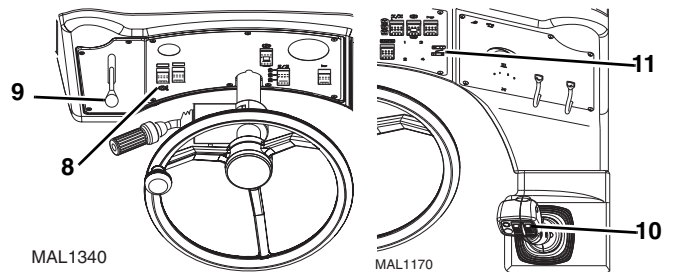

4. **TL642 - All**
TL943 - S/N TBL01599 & After including TBL01551 & TBL01585
 Press and hold the quick coupler switch (8). At the same time push the auxiliary hydraulic joystick (9) up to engage the lock pin or push the auxiliary hydraulic joystick down to disengage the lock pin.

- TL943 - S/N TBL01599 & After including TBL01551 & TBL01585**
 Press and hold the quick coupler switch (10). At the same time push the roller switch (11) down to engage the lock pin or push the roller switch up to disengage the lock pin.



Boom

5. Raise boom to eye level and visually check that the locking pin protrudes through the hole on both sides of the quick coupler. If the pins do not protrude through the hole, place the attachment on the ground and return to step 2.
6. If equipped, connect the attachment hydraulic hoses to the boom head auxiliary connections. Refer to Section 3.9.5, "Connecting with a Quick Coupler to a Hydraulic Operated Attachment."

3.9.5 Connecting with a Quick Coupler to a Hydraulic Operated Attachment

1. Install attachment. Refer to Section 3.9.3, "Connecting with a Mechanical Quick Coupler Device," or Section 3.9.4, "Connecting with a Hydraulic Quick Coupler Device."
2. Lower attachment to ground and set parking brake.

TL642 - S/N TBK01167 & After including TBL01162

TL943 - S/N TBL01599 & After including TBL01551 & TBL01585

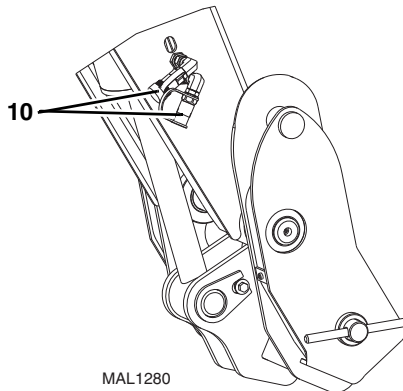

MAL1280

TL642 - S/N TBK01167 & After including TBL01162

TL943 - S/N TBL01599 & After including TBL01551 & TBL01585

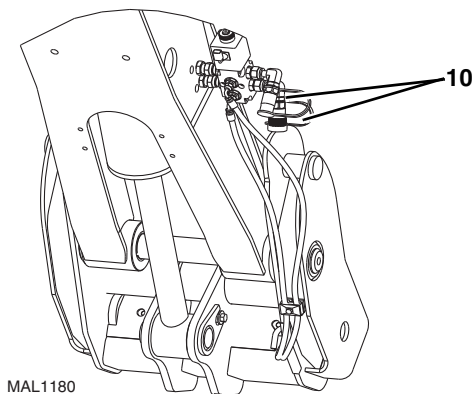

MAL1180

3. Connect the attachment hoses to both auxiliary fittings (10).

3.10 BOOM HEAD - MOUNTED WINCH

3.10.1 Boom Head-Mounted Winch Removal

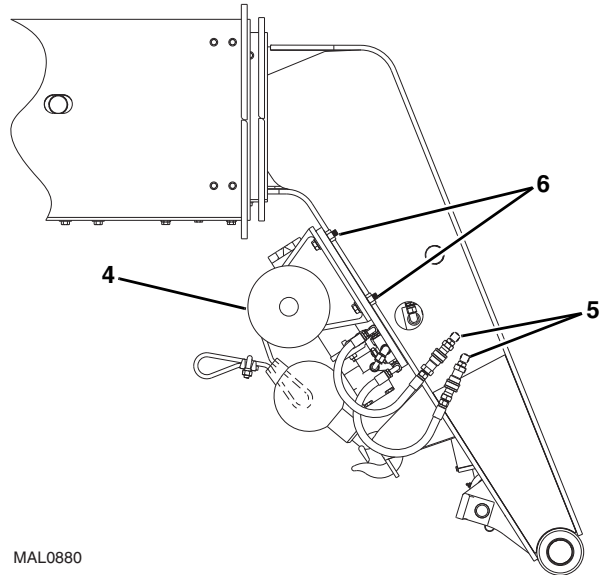

MAL0880

1. Using a suitable lifting device, secure the winch assembly (4) with a nylon strap.
2. Disconnect the hydraulic hoses (5).
3. Loosen and remove the mounting bolts, washers and nuts (6)(not shown).
4. Lower the winch assembly (4) onto a suitable skid or table.

3.10.2 Boom Head-Mounted Winch Installation

1. Using a suitable lifting device, secure the winch assembly (4) with a nylon strap.
2. Raise the winch assembly (4) into position behind the boom head.
3. Apply Loctite® 242™ to the previously removed mounting bolts.
4. Install the mounting bolts, washers and nuts (6)(not shown). Torque to 200 lb-ft.
5. Connect the hydraulic hoses (5).



3.11 BOOM WEAR PADS

The wear pads on this machine are flat rectangular wear pads with metal inserts.

A total of 30 wear pads are installed on the boom sections of the TL642 and TL943 machines.

3.11.1 Wear Pad Inspection

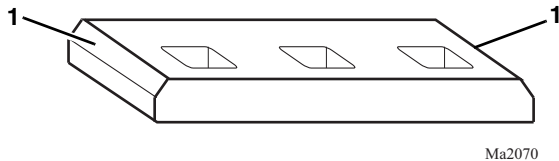

Inspect all wear pads for wear. If the angle indicators (1) on the end of the wear pads are visible, the wear pads can be reused. If the wear pads show uneven wear (front to back), they should be replaced. Replace wear pads as a set if worn or damaged.

3.11.2 Wear Pad Installation and Lubrication

Note: Inspect all wear pads. Replace as necessary.

The following wear pad procedure must be followed to insure the proper wear pad installation:

- The wear pad inserts and mounting bolts MUST be clean from any grease, oil or other contaminates before applying Loctite® 242™ and installing mounting bolts.
- Apply Loctite® 242™ to all wear pad mounting bolts.

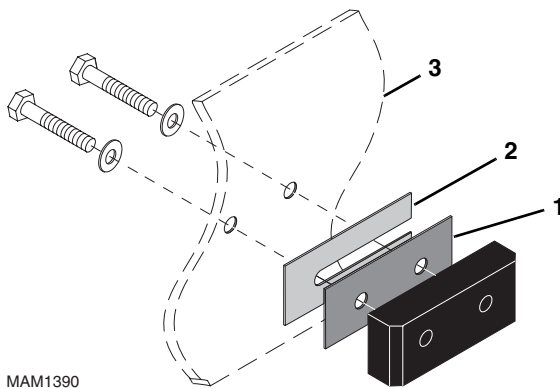

- A spacer (1) with holes must be used before any shim (2) is used.
- If required, a shim (2) must be inserted between the spacer (1) and wear pad support plate, block or boom section (3).
- The number of shims can vary at each shim point.
- The bottom wear pads must be shimmed equally on each side.

- Maintain a total boom section clearance of 0.070-0.130 in (1,78-3,30 mm) both the horizontal and vertical directions.

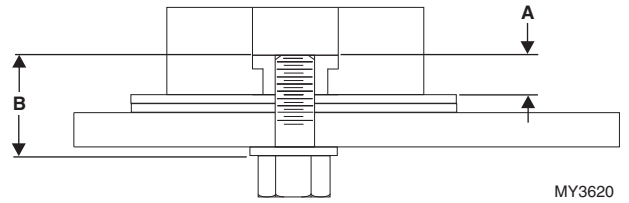

- The length of the wear pad bolt depends on the number of shims, spacers and washers being used.
- The thickness of each threaded wear pad insert is 0.312 in (7,92 mm)(A).
- The bolt length should be determined by measuring the distance from the face of the insert to the face of the boom (B) including any spacer, shim(s) and washer(s).
- Bolt thread engagement in the wear pad insert should be 0.275 ± 0.040 in (6,98 ± 1,0 mm).
- One or two hardened washers are to be used on each wear pad bolt except where noted otherwise. DO NOT use more than two hardened washers.
- Use only one hardened washer if mounting bolts are recessed.
- Wear Pad Bolt Torque:
 3/8-24 Bolt, 32-37 lb-ft (43-50 Nm)
 3/8-24 Hollow Bolt, 15-17 lb-ft (20-23 Nm)
 1/2-20 Bolt, 76-86 lb-ft (103-116 Nm)
 1/2 - 20 Hollow Bolt, 45-50 lb-ft (61-68 Nm)
- Torque wear pad bolts after shimming is completed.
- Lubricate the face and pockets of each wear pad after being installed.

Boom Section Wear Pad Pathway Lubrication:

- Clean and lightly grease all wear pad pathways with Mystik Tetrimoly grease.
- Clean and lightly grease the push beam guide bar pathways with Mystik Tetrimoly grease.



Boom

3.12 BOOM EXTEND AND RETRACT CHAINS

3.12.1 Boom Chain Inspection



WARNING

Worn pins, stretched or cracked links or corrosive environments can cause chain failure. A chain failure could result in uncontrolled boom movement, loss of load or machine instability.

Under normal operating conditions the boom chains will need to be inspected every 250 hours of operation. The retract chains need to be exposed and inspected every 1000 hours of operation. Environmental conditions and dynamic impulse/shock loads can drastically affect normal operating conditions and require more frequent inspection intervals.

Environments in which material handling vehicles operate can vary widely from outdoor moisture to temperature to mildly corrosive or highly corrosive industrial atmospheres, in addition to abrasive exposures such as sand and grit. Some effects can be as follows:

- Moisture - Corrosive rusting reduces chain strength by pitting and cracking.
- Temperature - Low temperature reduces chain strength by embrittlement. Going in and out of cold storage results in moisture from condensation.
- Chemical Solutions or Vapors - Corrosive attack on the chain components and/or the mechanical connections between the chain components. Cracking can be (and often is) microscopic. Going from microscopic cracking to complete failure can be either abrupt or may require an extended period of time.
- Abrasives - Accelerated wearing and scoring of the articulating members of the chain (pins and plates), with a corresponding reduction in chain strength. Due to the inaccessibility of the bearing surfaces (pin surfaces and plate apertures), wear and scoring are not readily noticeable to the naked eye.

Following are some examples of dynamic shock loading which can impose abnormal loads above the endurance limit of a leaf chain.

- High velocity movement of load, followed by sudden, abrupt stops.
- Carrying loads in suspension over irregular surfaces such as railroad tracks, potholes, and rough terrain.
- Attempting to “inch” loads which are beyond the rated capacity of the vehicle.

The above load cycles and environmental conditions make it impossible to predict chain life. It is therefore necessary to conduct frequent inspections until replacement life can be predicted.

The boom chain's normal life expectancy can be expressed as a maximum percent of elongation. This is generally 3%. As the chain flexes back and forth over the sheave, the bearing joints (pins and inside link plates) gradually incur wear due to articulation.

3.12.2 Inspection Guidelines

1. Park the machine on a firm, level surface, level the boom, place the transmission control lever in (N) NEUTRAL, engage the park brake switch.
2. Fully extend the boom until the extend chain is taut. Shut the engine off.
3. The extend chains will be visible for inspection with the vehicle in this state.
4. While doing the chain inspection, check all chain clevis ends for distortion or cracking and sheaves for bearing wear or grooving from the chain.
5. Inspect the retract chains every 1000 hours of operation.
6. Inspect the chains for the following conditions:

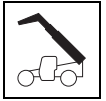

Edge Wear

Check the chain for wear on the link plate edges caused by running back and forth over the sheave. The maximum reduction of material should not exceed 5%. Measure and compare to a normal link plate height by measuring a portion of chain that does not run over the sheave. If the measured plate height (1) is 5% less than the normal plate height (2), discard and replace the chain.

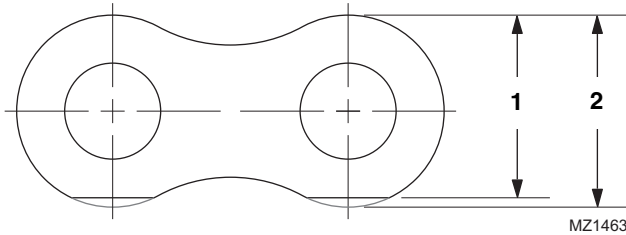

MZ1463

Elongation

It is important to measure the chain in the section that moves over the sheaves because it receives the most frequent articulation. Measuring the chain near its clevis terminals could give an inaccurate reading. The ends of the chains, near the clevis terminal, will not have flexed as frequently, if at all, as the middle of the chains.

It is best to measure in 12 pin increments from pin center to pin center. For example, if the links are one inch from pin center to pin center, the distance should be 12 in (305 mm). If the links are 3/4 in apart, the distance after 12 pins should be 9 in.

If the distance measured (3) is 3% greater than the normal length (4), discard and replace the chain.

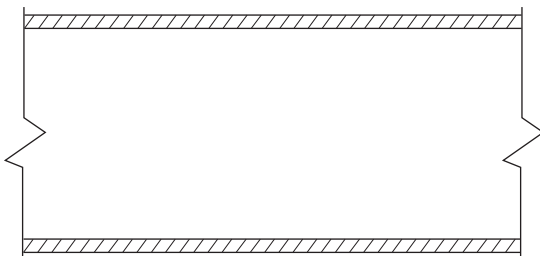
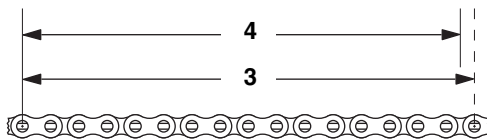

MY1360

Distorted or Battered Link Plates

Distorted or battered link plates (5) on a leaf chain can cause tight joints and prevent flexing.

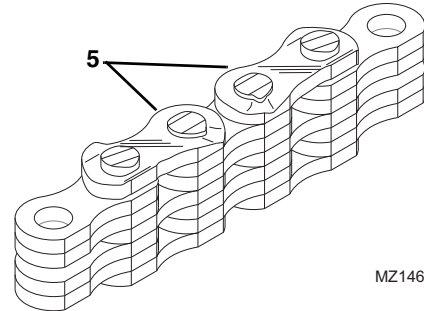

MZ1466

Turning or Protruding Pins

Highly loaded chain, operating with inadequate lubrication can generate abnormal frictional forces between pin and link plates. When chain is allowed to operate in this condition, a pin or series of pins, can begin to twist out of a chain, resulting in failure.

Examine the pin head rivets to determine if the "VEE" flats are still in correct alignment (6). Chain with rotated/displaced heads (7) or abnormal pin protrusion (8) should be replaced immediately.

DO NOT attempt to repair the chain by welding or driving the pin(s) back into the chain. Once the press fit integrity between outside plates and pins has been altered, it cannot be restored.

Any wear pattern on the pin heads or the sides of the link plates indicates misalignment in the system. This condition damages the chain as well as increases frictional loading and should be corrected.

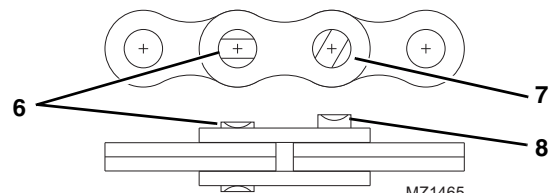

MZ1465



Boom

Cracked Plates

Inspect the chains very carefully, front and back as well as side to side, for any evidence of cracked plates. If any one crack is discovered, the chain should be replaced in its entirety.

It is important, however to determine the cause of the crack before installing a new chain so the condition does not repeat itself.

The types of cracks are:

- **Fatigue Cracking** - Fatigue cracks (9) are a result of repeated cyclic loading beyond the chain's endurance limit.
- **Stress Corrosion Cracking** - The outside link plates are particularly susceptible to stress corrosion cracking (10).
- **Corrosion Fatigue Cracking** - Corrosion fatigue cracks are very similar to fatigue cracks in appearance. Corrosion fatigue is the combined action of an aggressive environment and cyclic stress.

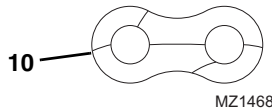
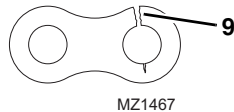

Other Modes of Failure

- **Ultimate Strength Failure** - These types of failures are caused by overloads far in excess of the design load. Either fractured plates (1) or enlarged holes (2) can occur. If either of these failures occurs, the chain should be replaced immediately.

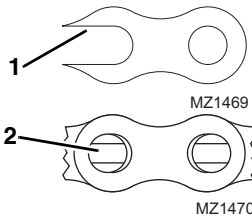

- **Tight Joints**

- All joints in the chain should flex freely. Tight joints (3) resist flexing.

If the problem is caused by dirt or foreign substance packed in the joints, clean and lubricate thoroughly before re-installing the chain.

If the problem is caused by corrosion and rust or bent pins, replace the chain.

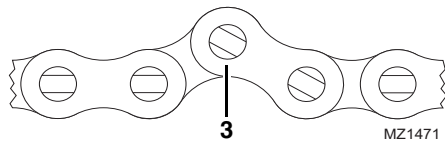

3.12.3 Chain Lubrication

After inspection and before being returned to service, chains must be lubricated with CAT Multipurpose Grease-NLGI Grade 2.

The lubricant must penetrate the chain joint to prevent wear. Applying lubricant to the external surfaces will prevent rust, but the chains should be articulated to make sure the lubricant penetrates to the working surfaces between the pins and links.

To prepare the chain for lubrication, the chain plates should be brushed with a stiff brush or wire brush to clear the space between the plates so that lubricant can penetrate to the working surfaces.

Lubricant may be applied with a narrow paint brush or directly poured on, but the chain should be well flooded with lubricant and the boom should be extended and retracted to be sure that the lubricant penetrates to the working surfaces. All surplus lubricant should be wiped away from the external surfaces. DO NOT use a solvent for this wiping operation.

Regular application of lubricant is necessary to make sure that all working surfaces are adequately lubricated. In extremely dusty conditions, it may be necessary to lubricate the chains more often. Refer to Section 2.5, "Service and Maintenance Schedules," and Section 2.6, "Lubrication Schedules," for detailed information.

Lubrication of chains on machines working consistently in extreme hot or cold conditions requires special consideration. Contact the local Caterpillar dealer for guidance.

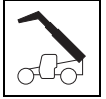

3.13 FORKS

Forks should be cleaned and inspected prior to being attached to carriage. If the following criteria is not met, forks must be removed from service immediately.

Daily Inspection

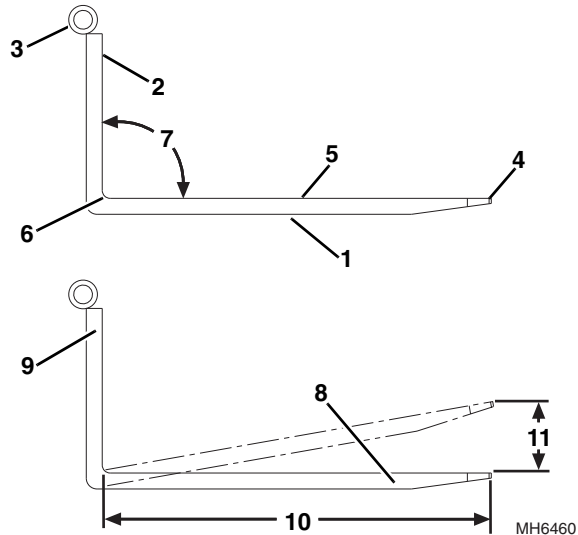

1. Inspect forks (1) for cracks, paying special attention to heel (2) and mounting tubes (3).
2. Inspect forks for broken or bent tips (4) and twisted blades (5) and shanks (6).

Yearly Inspection

1. Straightness of the upper face of blade (5) and the front face of shank (6) should not exceed 0.5 percent of the length of blade or height of shank.
2. Angle (7) between upper face of blade and front face of shank should not exceed 93 degrees.
3. Thickness of blade (8) and shank (9) should not be reduced to 90 percent of original thickness.

Note: Contact the local Caterpillar dealer with the fork part number to find the manufactured dimensions of the fork blade.

4. Ensure fork length (10) is adequate for intended loads.
5. Fork markings should be legible, re-stamp if required.
6. Compare fork tips (11) when mounted on a carriage. Maximum difference in height of fork tips is 3 percent of the length of the blade (10).



Boom

3.14 TROUBLESHOOTING

This section provides an easy reference guide covering the most common problems that occur during operation of the boom.

Problem	Cause	Remedy
1. Boom will not extend or retract	<ol style="list-style-type: none"> 1. Broken hydraulic hose(s) or tube(s) and/or connections leaking. 2. Extend/retract hydraulic system not operating properly. 3. Faulty extend/retract cylinder. 	<ol style="list-style-type: none"> 1. Locate break, replace hose(s) or tube(s), tighten connections. 2. Refer to Section 8.4, "Hydraulic Circuits." 3. Repair cylinder, Refer to Section 8.8.1, "General Cylinder Removal Instructions."
2. Boom shifts to right or left when extending.	<ol style="list-style-type: none"> 1. Boom side wear pads improperly shimmed or worn. 	<ol style="list-style-type: none"> 1. Shim wear pads to correct gap. Replace wear pads as needed. Refer to Section 3.11, "Boom Wear Pads."
3. Excessive boom pivot pin noise and/or wear.	<ol style="list-style-type: none"> 1. Insufficient lubrication. 2. Worn bearing(s). 	<ol style="list-style-type: none"> 1. Lubricate at regular intervals. Refer to Section 2.6, "Lubrication Schedules." Replace worn pins as needed. 2. Lubricate at regular intervals. Refer to Section 2.6, "Lubrication Schedules." Replace worn pins as needed.
4. Excessive Compensation cylinder pivot pin noise and/or wear.	<ol style="list-style-type: none"> 1. Insufficient lubrication. 2. Worn bushing(s). 	<ol style="list-style-type: none"> 1. Lubricate at regular intervals. Refer to Section 2.6, "Lubrication Schedules." Replace worn pins as needed. 2. Replace bushing(s) and lubricate at regular intervals.



Problem	Cause	Remedy
<p>5. Drooping chain, or jerky boom extend or retract functions.</p>	<ol style="list-style-type: none"> 1. Chain(s) tension not properly adjusted. 2. Chain(s) stretched or binding. 3. Wear pads loose, contaminated, excessively worn or damaged. 4. Contaminated, corroded or rusted wear pad sliding surfaces. 5. Extend/Retract hydraulic system not operating properly. 6. Damaged boom section. 	<ol style="list-style-type: none"> 1. Adjust chain(s). 2. Replace chains as needed. Refer to Section 3.8, "Boom Section Separation Adjustment." 3. Replace wear pad. Refer to Section 3.11, "Boom Wear Pads." 4. Remove contamination and/or corrosion from wear pad sliding surfaces and lubricate. If the surfaces cannot be reconditioned, replace the boom section(s). 5. Refer to Section 8.4, "Hydraulic Circuits." 6. Replace the damaged boom section. Refer to Section 3.3, "Boom Assembly Maintenance."
<p>6. Boom will not raise or lower.</p>	<ol style="list-style-type: none"> 1. Broken hydraulic hoses or tubes and/or connection leaks. 2. Lift/lower hydraulic system not operating properly. 3. Faulty lift/lower cylinder. 4. Seized boom pivot pin bearing. 	<ol style="list-style-type: none"> 1. Locate break, replace hose(s) or tube(s), tighten connections. 2. Refer to Section 8.4, "Hydraulic Circuits." 3. Repair cylinder. Refer to Section 8.8.1, "General Cylinder Removal Instructions." 4. Replace bearing.
<p>7. Excessive Lift/Lower cylinder pivot pin noise and/or wear.</p>	<ol style="list-style-type: none"> 1. Insufficient lubrication. 2. Worn self-aligning bushing(s). 	<ol style="list-style-type: none"> 1. Lubricate at regular intervals. Refer to Section 2.5, "Service and Maintenance Schedules." Replace worn pins as needed. Refer to Section 8.8.1, "General Cylinder Removal Instructions." 2. Replace bushing(s) and lubricate at regular intervals. Refer to Section 2.6, "Lubrication Schedules."



Boom

Problem	Cause	Remedy
8. Rapid boom pad wear.	<ol style="list-style-type: none"> 1. Incorrect wear pad gap. 2. Rapid cycle times with heavy loads. 3. Contaminated, corroded or rusted wear pad sliding surfaces. 4. Operating in extremely dusty/abrasive conditions. 	<ol style="list-style-type: none"> 1. Check wear pad gaps and correct as needed. Refer to Section 3.11, "Boom Wear Pads." 2. Reduce cycle times. 3. Remove contamination and/or corrosion from wear pad sliding surfaces and lubricate. If the surfaces cannot be reconditioned, replace the boom section(s). 4. Clean equipment frequently.
9. Auxiliary hydraulics will not operate.	<ol style="list-style-type: none"> 1. Auxiliary hydraulic system not operating properly. 	<ol style="list-style-type: none"> 1. Refer to Section 8.4, "Hydraulic Circuits."
10. Excessive chain wear.	<ol style="list-style-type: none"> 1. Improper chain adjustment. 2. Chain sheave(s) not properly lubricated. 3. Chain sheave(s) not rotating freely. 4. Improper chain lubrication. 	<ol style="list-style-type: none"> 1. Adjust to correct tension. Refer to Section 3.8, "Boom Section Separation Adjustment." - Replace chains as needed. 2. Lubricate chain sheave. Refer to Section 2.5, "Service and Maintenance Schedules." 3. Lubricate chain sheave. Refer to Section 2.5, "Service and Maintenance Schedules." Repair or replace chain sheave(s) as needed. 4. Lubricate at regular intervals. Refer to Section 2.5, "Service and Maintenance Schedules." Replace chains as needed.

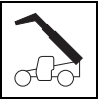

3.15 PUSH BEAM TEMPORARY BRACKETS

Note: The drawings below are only suggested and can be subject to individual interpretation.

Temporary Extend Chain Bracket

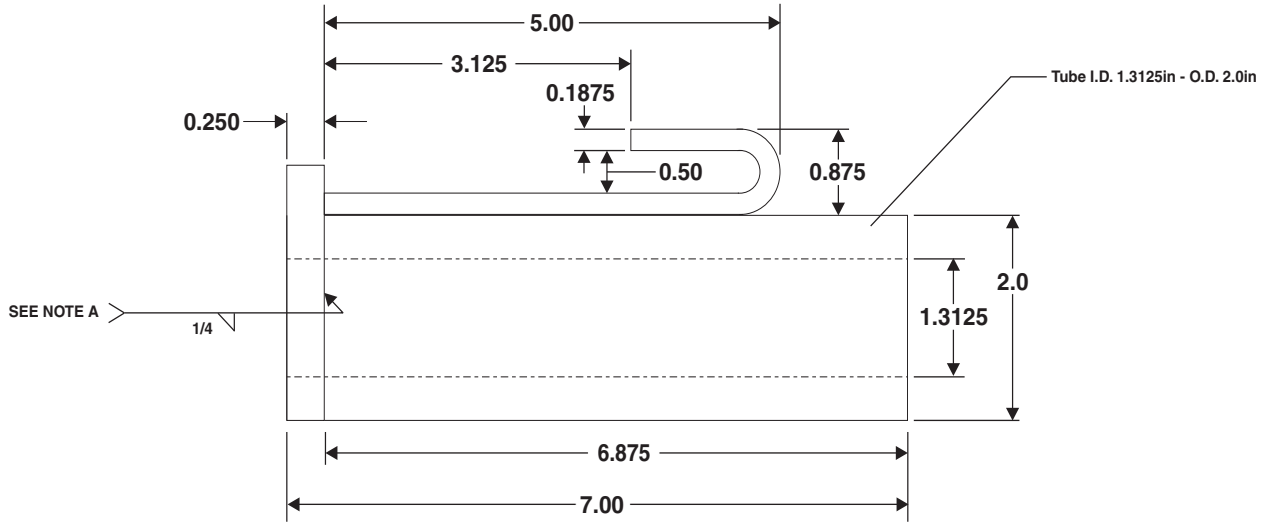

Temporary Retract Chain Bracket

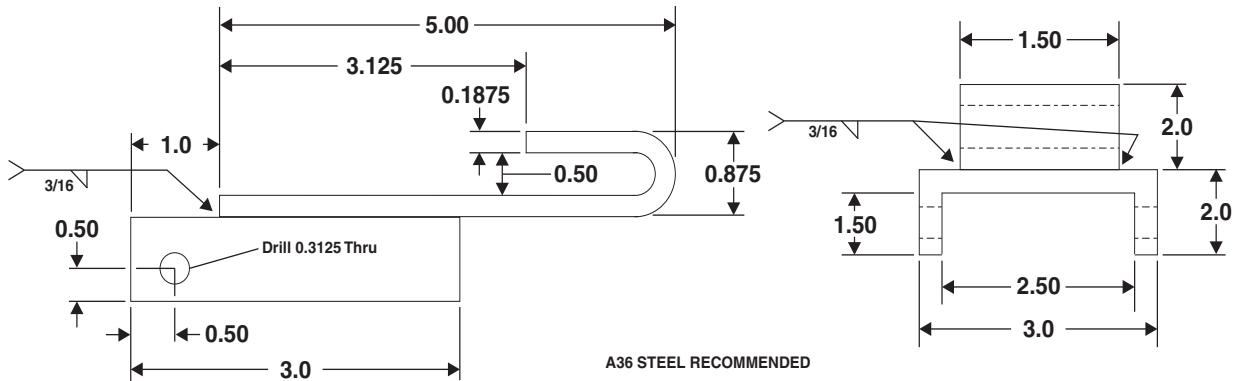

A36 STEEL RECOMMENDED
ALL WELDS SHALL CONFORM TO AWS D1.1
ALL DIMENSIONS ARE IN INCHES

MY4100



Boom

This Page Intentionally Left Blank



Section 4 Cab and Covers

Contents

PARAGRAPH	TITLE	PAGE
4.1	Operator Cab and Covers Component Terminology	4-2
4.1.1	General Overview	4-2
4.1.2	General Overview	4-3
4.2	Operator Cab	4-4
4.2.1	Cab Safety	4-4
4.2.2	Serial Number Decal	4-4
4.3	Cab Components	4-4
4.3.1	Steering Column and Orbitrol Valve	4-4
4.3.2	Service Brake Pedal	4-5
4.3.3	Throttle Pedal	4-6
4.3.4	Boom Joystick	4-7
4.3.5	Frame Level, Auxiliary Hydraulic (if equipped) and Outrigger Joysticks .	4-8
4.3.6	Windshield Wiper Assembly	4-8
4.3.7	Heater/Air Conditioning System (if equipped)	4-9
4.4	Cab Removal	4-10
4.5	Cab Installation	4-11



4.1 OPERATOR CAB AND COVERS COMPONENT TERMINOLOGY

To understand the safety, operation and maintenance information presented in this section, it is necessary that the operator/mechanic be familiar with the names and locations of the major assemblies of the machine cab and covers. The following illustration identifies the components that are referred to throughout this section.

4.1.1 General Overview

TL642 - Before S/N TBK01167 excluding TBK01162

TL943 - Before S/N TBL01599 excluding TBL01551 & TBL01585

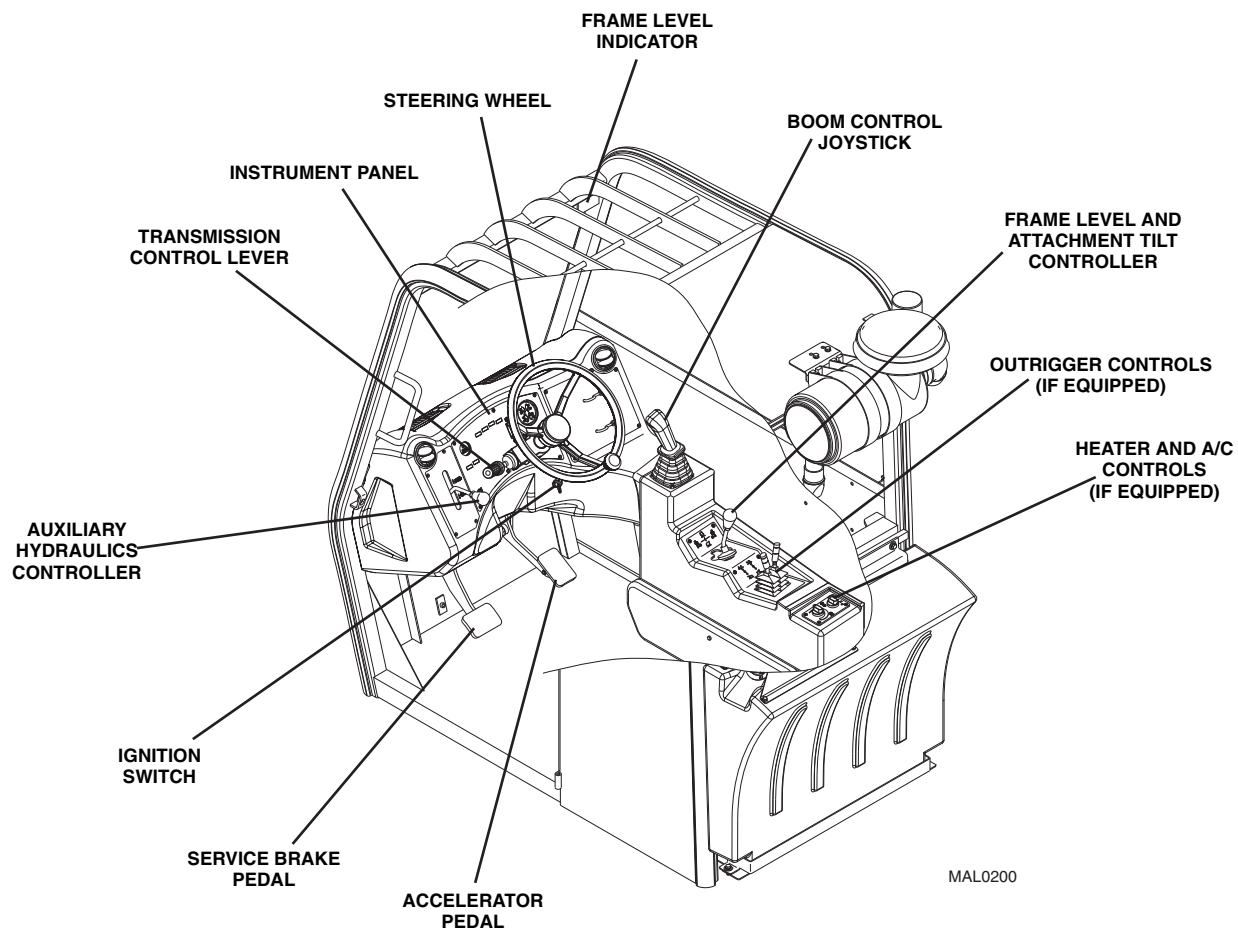



4.1.2 General Overview

TL642 - S/N TBK01167 & After including TBK01162

TL943 - S/N TBL01599 & After including TBL01551 & TBL01585

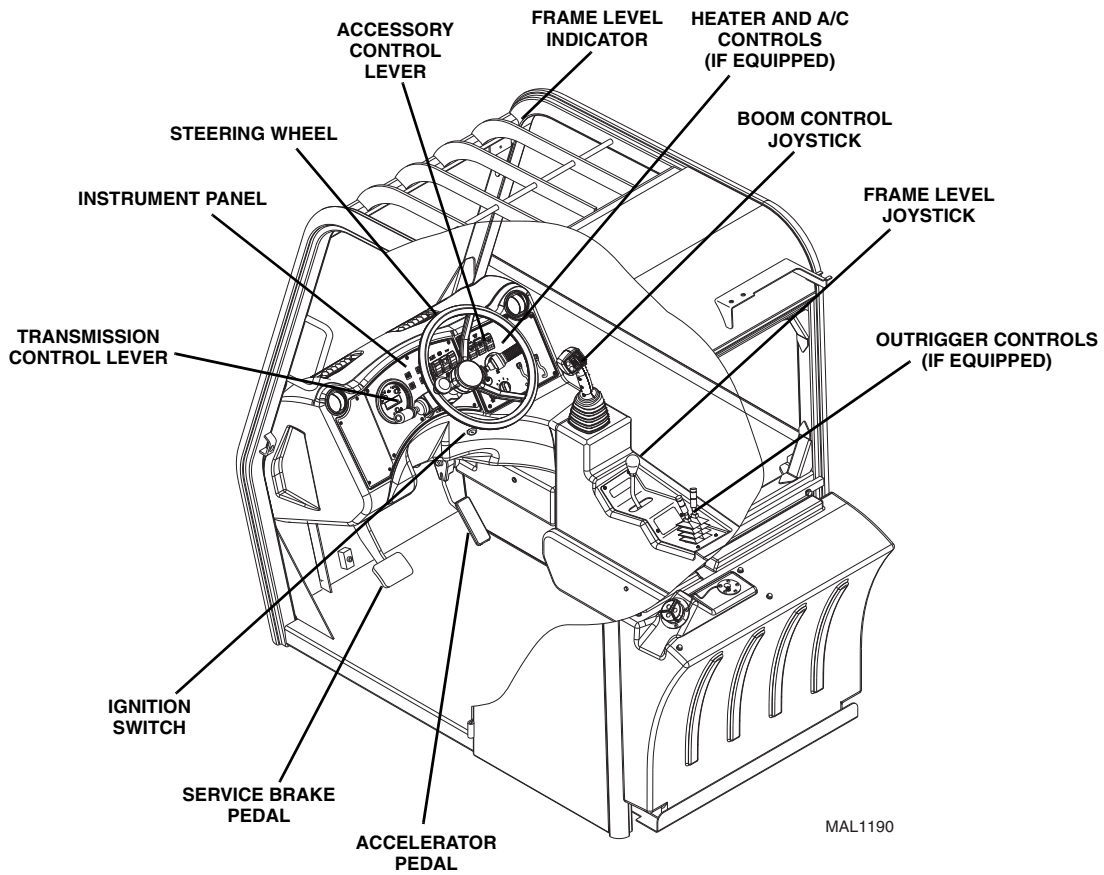



Cab and Covers

! WARNING

DO NOT service the machine without following all safety precautions as outlined in the “Safety Practices” section of this manual.

4.2 OPERATOR CAB

4.2.1 Cab Safety

! WARNING

The protection offered by this ROPS/FOPS will be impaired if subjected to any modification or structural damage, at which time replacement is necessary. ROPS/FOPS must be properly installed using fasteners of correct size and grade, and torqued to their specified value.

! WARNING

DO NOT weld, grind, drill, repair or modify the cab in any way. Any modification or damage to cab structural components requires cab replacement. Refer to the Operation & Maintenance Manual.

To help ensure optimum safety, protection and performance, replace the cab if it is damaged. Refer to the appropriate parts manual for ordering information.

4.2.2 Serial Number Decal

The cab serial number decal is located on the left side of the cab, behind the seat. Information specified on the serial number plate includes the cab model number, the cab serial number and other data. Write this information down in a convenient location to use in cab correspondence.

4.3 CAB COMPONENTS

4.3.1 Steering Column and Orbitrol Valve

a. Orbitrol Valve Removal

1. Park the machine on a firm, level surface, level the machine, fully retract the boom, lower the boom, place the travel select lever in the (N) NEUTRAL

position, engage the parking brake and turn the engine OFF.

2. Place a Do Not Operate Tag on both the ignition key switch and the steering wheel, stating that the machine should not be operated.
3. Open the engine cover. Allow the system fluids to cool.
4. Properly disconnect the battery.

Note: It may be necessary to remove the main dash panel to gain access to the appropriate hydraulic hoses. Refer to Section 9.12, “Gauges and Display Monitor.”

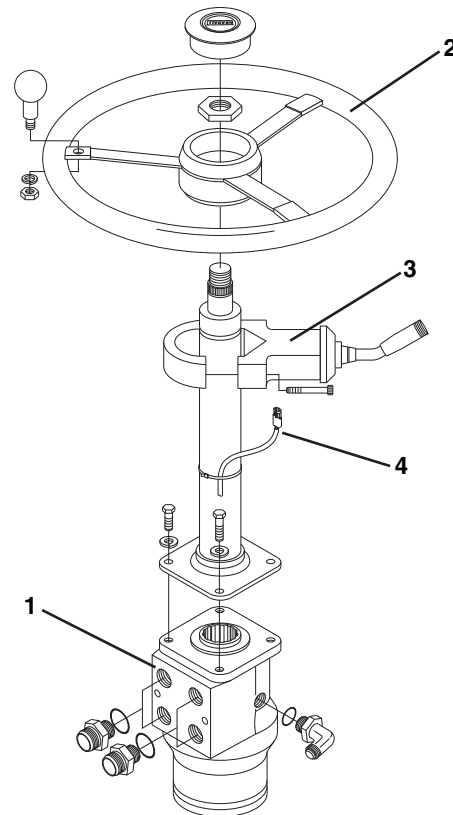

MY0120

5. Label, disconnect and cap the four hoses from the side of the steering valve (1). Cap the fittings on the steering valve. Label, disconnect and plug the load sense hose at the front of the steering valve. Cap the fitting on the steering valve.
6. Remove the steering wheel (2), disconnect and remove the travel select lever (3), disconnect the instrument panel harness connector (4).
7. Remove the steering assembly through the dash panel opening.
8. Support the steering valve, and remove the four hex-head capscrews and four lockwashers.



Note: *DO NOT* disassemble the orbitrol valve. The orbitrol valve is not serviceable and must be replaced in its entirety, if defective.

b. Orbitrol Valve Installation

1. Secure the steering valve to the steering column with four hex-flange capscrews and four lockwashers.
2. Install the steering column through the dash panel opening. Position steering valve to its original orientation in the cab.
3. Install the travel select lever, connect the instrument panel harness connector, install the steering wheel assembly. Torque the steering wheel nut to 29-34 lb-ft (39-46 Nm).
4. Install new o-rings into the steering valve fittings. Lubricate the o-rings with clean hydraulic oil.
5. Uncap and connect the previously labeled load sense hose to the steering valve.
6. Uncap and connect the remaining previously labeled four hoses to the steering valve.

Note: *If necessary, install the main dash panel. Refer to Section 9.12, "Gauges and Display Monitor."*

7. Properly connect the battery.
8. Carefully examine all connections one last time before engine start-up. Rectify any faulty conditions.
9. Start the engine and check the operation of steering system. Check for hydraulic fluid leaks. Check the hydraulic fluid level in the tank and add fluid as required.
10. Close and secure the engine cover.
11. Remove the Do Not Operate Tags from both the ignition key switch and the steering wheel.

c. Steering Test

Conduct a pressure check of the steering hydraulic circuits at the main control valve. Refer to Section 8.3.1, "Pressure Checks and Adjustments."

4.3.2 Service Brake Pedal

a. Brake Valve Removal

Refer to Section 8.7.2, "Service Brake Valve," for removal information.

b. Brake Valve Installation

Refer to Section 8.7.2, "Service Brake Valve," for installation information.

c. Service Brake Pedal Removal

1. Park the machine on a firm, level surface, level the machine, fully retract the boom, lower the boom, place the travel select lever in the (N) NEUTRAL position, engage the parking brake and turn the engine OFF.
2. Place a Do Not Operate Tag on both the ignition key switch and steering wheel, stating that the machine should not be operated.
3. Open the engine cover. Allow the system fluids to cool.
4. Properly disconnect the battery.

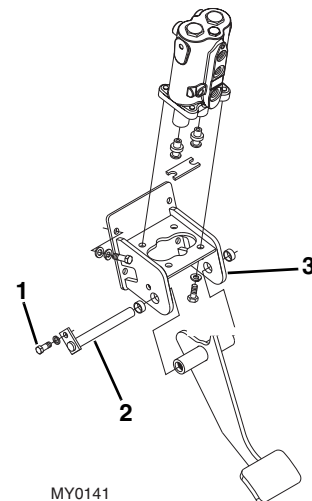

5. Remove the bolt and lockwasher (1) securing the service brake pedal pivot pin (2).
6. Pull the pivot pin from the service brake pedal bracket (3).
7. Remove the service brake pedal from the cab.

d. Service Brake Pedal Installation

1. Position the service brake pedal in its mounting location within the cab.
2. Secure the brake pedal into position with the pivot pin.
3. Be sure the brake pedal has the correct range of motion. Secure pivot pin with bolt and lockwasher.
4. Properly connect the battery.
5. Close and secure the engine cover.
6. Remove the Do Not Operate Tags from both the ignition key switch and the steering wheel.



4.3.3 Throttle Pedal

TL642 - Before S/N TBK01167 excluding TBK01162

TL943 - Before S/N TBL01599 excluding TBL01551 & TBL01585

a. Throttle Pedal Removal

1. Park the machine on a firm, level surface, level the machine, fully retract the boom, lower the boom, place the travel select lever in the (N) NEUTRAL position, engage the parking brake and turn the engine OFF.
2. Place a Do Not Operate Tag on both the ignition key switch and steering wheel, stating that the machine should not be operated.
3. Properly disconnect the battery.

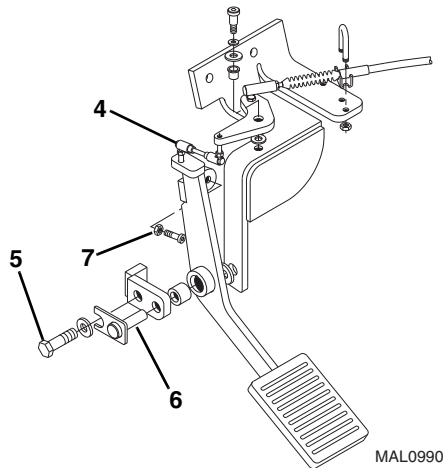

4. Remove the ball joint (4) connected to the throttle pedal.
5. Remove the bolt and lockwasher (5) securing the throttle pedal pivot pin (6).
6. Remove the throttle pedal assembly from the cab.

b. Throttle Pedal Installation

1. Position the throttle pedal in its mounting location within the cab.
2. Secure the throttle pedal into position with the pivot pin.
3. Install the throttle pedal ball joint to the throttle pedal.
4. Properly connect the battery.
5. Close and secure the engine cover.
6. Remove the Do Not Operate Tags from both the ignition key switch and the steering wheel.

c. Throttle Adjustment

1. From within the cab, lightly depress the accelerator pedal to the full-throttle position. As needed, adjust the limit-stop screw (7) until it touches the pedal. Tighten the locknut.

Note: During the full throttle check:

- **DO NOT** operate any hydraulic function.
 - **DO NOT** steer or apply any pressure to the steering wheel.
 - Keep the transmission in (N) NEUTRAL.
2. Check the engine rpm at full throttle. If the rpm is not within the specified range, readjust the throttle limit screw at the throttle pedal within the cab. Refer to Section 2.3.5, "Engine Performance Specifications."

TL642 - S/N TBK01167 & After including TBK01162

TL943 - S/N TBL01599 & After including TBL01551 & TBL01585

a. Throttle Pedal Removal

1. Park the machine on a firm, level surface, level the machine, fully retract the boom, lower the boom, place the travel select lever in the (N) NEUTRAL position, engage the parking brake and turn the engine OFF.
2. Place a Do Not Operate Tag on both the ignition key switch and steering wheel, stating that the machine should not be operated.
3. Properly disconnect the battery.

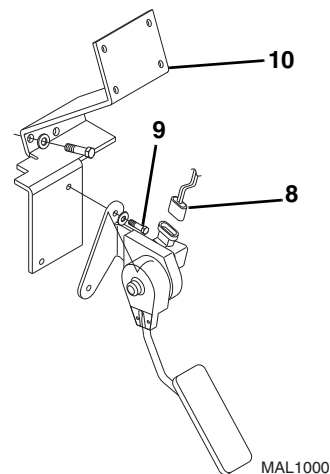

4. Disconnect the electrical harness connector (8).
5. Remove the bolts (9) securing the throttle pedal to the throttle pedal bracket (10).
6. Remove the throttle pedal assembly from the cab.



b. Throttle Pedal Installation

1. Position the throttle pedal in its mounting location within the cab.
2. Secure the throttle pedal into position with the pivot pin.
3. Install the throttle pedal ball joint to the throttle pedal.
4. Properly connect the battery.
5. Verify proper throttle pedal operation.
6. Close and secure the engine cover.
7. Remove the Do Not Operate Tags from both the ignition key switch and the steering wheel.

4.3.4 Boom Joystick

a. Joystick Removal

1. Park the machine on a firm, level surface, level the machine, fully retract the boom, lower the boom, place the travel select lever in the (N) NEUTRAL position, engage the parking brake and turn the engine OFF.
2. Place a Do Not Operate Tag on both the ignition key switch and steering wheel, stating that the machine should not be operated.
3. Properly disconnect the battery.

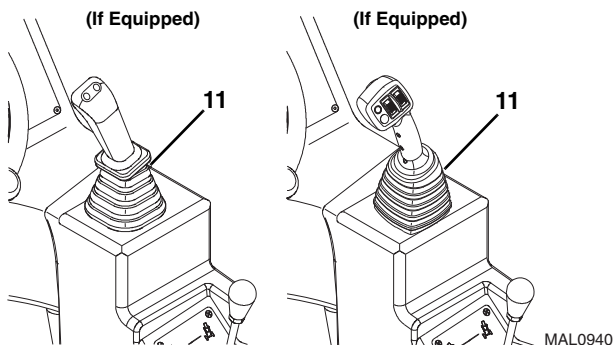

4. Lift the joystick's rubber sleeve (11), remove the bolts securing the boom joystick to the cab.
5. Lift the joystick from its mounting position.
6. Label, disconnect and cap the hydraulic hoses attached to the boom joystick.
7. Disconnect the electrical connectors.
8. Remove the joystick.

b. Joystick Installation

1. Uncap and connect the previously labeled hydraulic hoses to their appropriate locations.
2. Connect the electrical connectors.
3. Install the bolts securing the joystick to the cab.
4. Properly connect the battery.
5. Test the joystick functions:
 - a. Move the joystick handle rearward, activating the boom lift function. The boom should RISE.
 - b. Move the joystick handle forward, activating the boom lower function. The boom should LOWER.
 - c. Move the joystick handle to the right, activating the boom extend function. The boom should EXTEND.
 - d. Move the joystick handle to the left, activating the boom retract function. The boom should RETRACT.

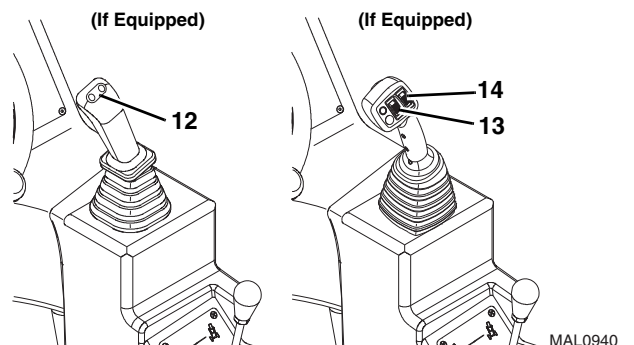

- e. Depress the left side of the switch (12) to activate the tilt up function or roll the left roller (13) down to activate the tilt up function. The attachment should TILT UP.
- f. Depress the right side of the switch (12) to activate the tilt down function or roll the left roller (13) up to activate the tilt down function. The attachment should TILT DOWN.
- g. If equipped, roll the right roller (14) up and/or down to activate the Auxiliary Hydraulic function.

Note: Check the controls of the auxiliary attachments. See the appropriate Operation & Maintenance Manual for an approved list of attachments and control instructions.

6. Close and secure the engine cover.
7. Remove the Do Not Operate Tags from both the ignition key switch and the steering wheel.



Cab and Covers

4.3.5 Frame Level, Auxiliary Hydraulic (if equipped) and Outrigger Joysticks

a. Joystick Removal

1. Park the machine on a firm, level surface, level the machine, fully retract the boom, lower the boom, place the travel select lever in the (N) NEUTRAL position, engage the parking brake and turn the engine OFF.
2. Place a Do Not Operate Tag on both the ignition key switch and steering wheel, stating that the machine should not be operated.
3. Properly disconnect the battery.

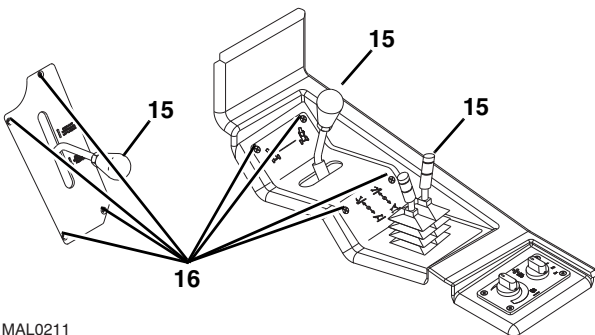

MAL0211

4. Remove the knob on the end of the joystick (15) if necessary.
5. Remove the screws (16) securing the dash panel to the cab. Remove the dash panel.
6. Remove any hardware securing the joystick to the cab.
7. Label, disconnect and cap the hydraulic fittings attached to the joystick.
8. Remove the joystick from the cab.

b. Joystick Installation

1. Uncap and connect the previously labeled hydraulic hoses to their appropriate locations.
2. Install the bolts securing the joystick to the cab.
3. Install the dash panel to its original position with the previously used hardware.
4. Install the joystick knob (if necessary).
5. Properly connect the battery.
6. Test the joystick functions:

Frame Level Joystick

- a. Move the joystick handle to the right, activating the right frame level function. The frame should rotate to the RIGHT.
- b. Move the joystick handle to the left, activating the left frame level function. The frame should rotate to the LEFT.

Auxiliary Hydraulic Joystick (if equipped)

Check the controls of the auxiliary attachments. See the appropriate Operation & Maintenance Manual for an approved list of attachments and control instructions.

Outrigger Control Joysticks (if equipped)

Move each joystick forward, the outrigger should lower. Move each joystick rearward, the outrigger should raise.

7. Close and secure the engine cover.
8. Remove the Do Not Operate Tags from both the ignition key switch and the steering wheel.

4.3.6 Windshield Wiper Assembly

Refer to Section 9.9, "Window Wiper/Washer Windshield Wiper Motor," for removal and installation information.



4.3.7 Heater/Air Conditioning System (if equipped)

Note: If machine is equipped with air conditioning, DO NOT loosen or disconnect any air conditioning hoses until the air conditioning system has been properly drained by the local Caterpillar dealer or certified air conditioning service center.

a. Heater/AC Assembly Removal

1. Park the machine on a firm, level surface, level the machine, fully retract the boom, lower the boom, place the travel select lever in the (N) NEUTRAL position, engage the park brake and shut the engine OFF.
2. Place a Do Not Operate Tag on both the ignition key switch and the steering wheel, stating that the machine should not be operated.
3. Open the engine cover. Allow the system fluids to cool.
4. Properly disconnect the battery.
5. Place a suitable container beneath the radiator. Slowly turn the radiator cap to the first stop, allow any pressure to escape. Remove the radiator cap.
6. Place a funnel at the base of the radiator to channel the drained coolant into the container. Loosen the drain petcock and allow the coolant to drain.
7. Transfer the coolant to a container with a cover, and label as "Used Antifreeze." Dispose of the used coolant at an approved recycling facility.
8. Tighten the radiator drain petcock.
9. Remove the bolts that secure the seat to the cab. Remove the seat.

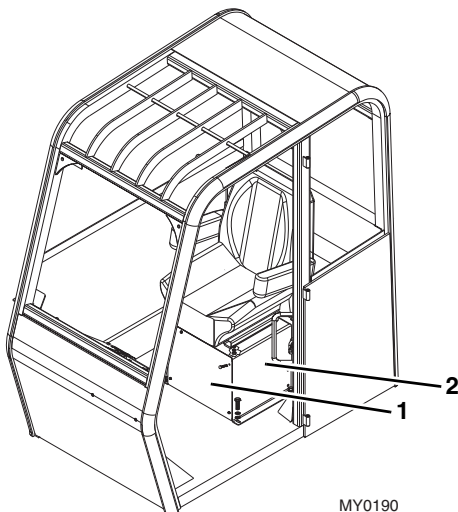

10. Remove the bolts securing the front plate (1) to the seat riser weldment (2).
11. Remove the bolts securing the seat riser weldment to the cab. Remove the riser weldment.

HEATER WITH AIR CONDITIONING SHOWN

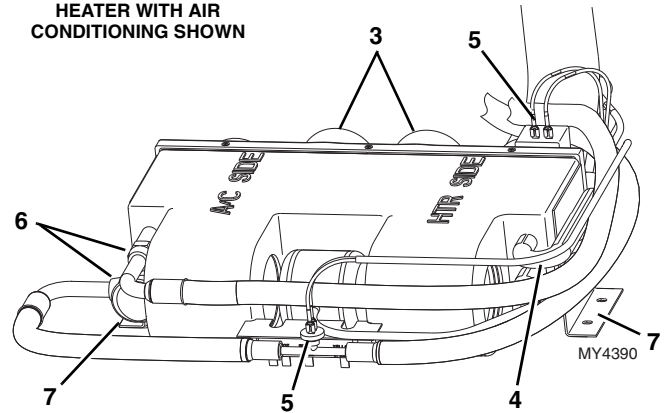

12. Loosen the hose and disconnect the heater air duct hoses (3).
13. Loosen the hose clamps securing the heater hoses (4).
14. Label and remove both heater hoses.
15. Label and disconnect any electrical connections (5).
16. Label and disconnect both air conditioning hoses (6).
17. Remove the bolts (7) securing the heater assembly to the cab. Remove the heater assembly.

b. Heater/AC Assembly Installation

Note: If machine is equipped with air conditioning, the air conditioning system must be charged by the local Caterpillar dealer or certified air conditioning service center.

1. Position the heater assembly to its original orientation in the cab. Secure with the previous hardware.
2. Connect the previously labeled electrical connections.
3. Connect the previously labeled heater hoses to their appropriate locations.
4. Connect the previously labeled air conditioning hoses to their appropriate locations.
5. Install the seat riser weldment.
6. Install the front plate to the seat riser weldment.
7. Install the cab seat.
8. Fill the cooling system completely with coolant, allowing time for the coolant to fill the engine block.



Cab and Covers

The cooling system capacity is listed in Section 2.4, “Fluids and Lubricant Capacities.”

9. Properly connect the battery.

Note: When the engine is initially started, run it briefly at low idle and check the machine for any visual sign of fluid leakage. STOP the engine immediately if any leakage is noted, and make any necessary repairs before continuing.

10. Wait for the engine to cool and check the coolant level. Add coolant as required to bring the coolant to the proper level.
11. Remove the Do Not Operate Tags from both the ignition key switch and the steering wheel.

4.4 CAB REMOVAL

WARNING

The protection offered by this ROPS/FOPS will be impaired if subjected to any modification or structural damage, at which time replacement is necessary. ROPS/FOPS must be properly installed using fasteners of correct size and grade, and torqued to their specified value.

Note: To help ensure safety and optimum performance, replace the cab if it is damaged. Refer to the appropriate parts manual for ordering information.

Inspect the cab, its welds and mounts. If modification, damage, a cracked weld and/or fatigued metal is discovered, replace the cab. Contact the local Caterpillar dealer with any questions about the suitability or condition of a cab.

Note: Remove and label cab components as needed before removing the cab from the machine. Label, disconnect and cap hydraulic hoses. Transfer cab parts to the replacement cab after the replacement cab is securely mounted on the machine.

1. Park the machine on a firm, level surface. Allow sufficient overhead and side clearance for cab removal. Level the machine, fully retract the boom, lower the boom, place the travel select lever in the (N) NEUTRAL position, engage the park brake and shut the engine OFF.
2. Block all four wheels to help prevent the machine from moving. Assure that there is sufficient overhead and side clearance for cab removal.
3. Open the engine cover. Allow the system fluids to cool.

4. Properly disconnect the battery.
5. Place a funnel at the base of the radiator to channel the drained coolant into the container. Loosen the drain petcock and allow the coolant to drain.
6. Transfer the coolant to a container with a cover, and label as “Used Antifreeze.” Dispose of the used coolant at an approved recycling facility.
7. Tighten the radiator drain petcock.
8. Disconnect the cab heater hoses. Refer to Section 4.3.7, “Heater/Air Conditioning System (if equipped).”
9. Remove the necessary dash panels to gain access to the electrical wiring connections. Label and disconnect the harnesses. Push the harness connectors through the opening in the cab.
10. If equipped, remove the boom joystick from its mounting position. Refer to Section 4.3.4, “Boom Joystick.” Label, disconnect and cap all hydraulic hoses attached to the boom joystick. Cap all fittings and openings to keep dirt and debris from entering the hydraulic system.
11. Remove the frame level and attachment tilt and auxiliary control joystick. Refer to Section 4.3.5, “Frame Level, Auxiliary Hydraulic (if equipped) and Outrigger Joysticks.” Label, disconnect and cap all hydraulic hoses attached to the joystick. Cap all fittings and openings to keep dirt and debris from entering the hydraulic system.
12. Label, disconnect and cap all hydraulic hoses attached to the steering orbitrol valve. Cap all fittings and openings to keep dirt and debris from entering the hydraulic system.
13. Label, disconnect and cap all hydraulic hoses attached to the steering orbitrol valve. Cap all fittings and openings to keep dirt and debris from entering the hydraulic system.
14. Label, disconnect and cap all hydraulic hoses attached to the service brake valve. Cap all fittings and openings to keep dirt and debris from entering the hydraulic system.
15. Push all the hydraulic hoses through the opening in the cab.
16. Disconnect the throttle cable from the throttle assembly. Refer to Section 4.3.3, “Throttle Pedal.”
17. Disconnect the engine air filter and hydraulic oil reservoir breather from their brackets at the top of the cab. Move the air filter and breather clear from the cab so they do not become damaged during cab removal.



- Remove the fuel tank from the cab. Refer to Section 7.6.2, "Fuel Tank."

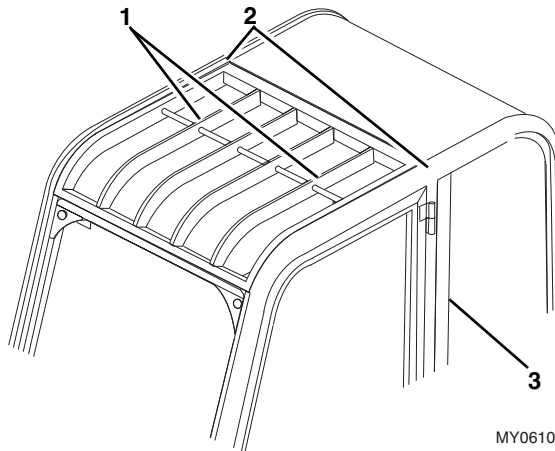

- Open Cab: Route a sling with a minimum lifting capacity of 1000 lb (453 kg) under the inner four braces (1) and behind the center cross support above the wind shield or install two lifting eye bolts (2) in the threaded holes on the roof of the cab above the B pillars (15).
- Enclosed Cab: Install two lifting eye bolts (14) in the threaded holes on the roof of the cab above the B pillars (3).

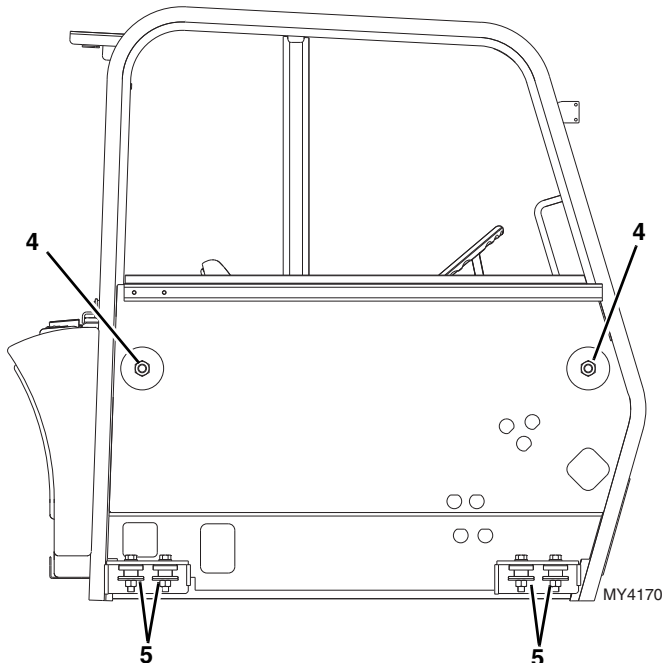

- Remove the two cab side-mount bolts in the cab (4).
- Remove the four cab-to-frame bolts, flat washers and nuts (5).
- Remove the mirrors and all other cab components as needed, if not previously removed.

- Carefully begin to lift the cab. Stop and check that all wiring, hydraulic hoses and fasteners are disconnected or removed.
- When all wiring, hydraulic hoses and fasteners are disconnected or removed, carefully and slowly lift the cab and remove it from the frame. Readjust the position of the sling as needed to help balance the cab during removal.
- When the cab is completely clear of the machine, carefully lower it to the ground. Block up or support the cab so that it does not move or fall. Assure that no personnel enter the cab while it is being removed from the machine.
- Inspect the condition of the fittings, clamps, hydraulic hoses, etc. Replace parts as indicated by their condition.
- Inspect and replace other machine parts that are exposed with the cab removed. Repair or replace as required.

4.5 CAB INSTALLATION

- Block all four wheels to help prevent the machine from moving. Assure that there is sufficient overhead and side clearance for cab installation.

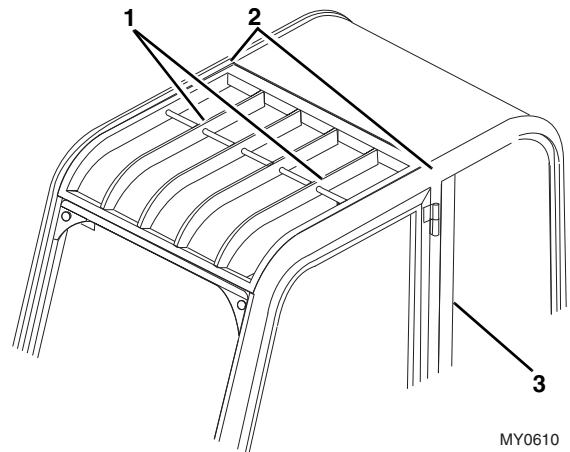

- Open Cab: Route a sling with a minimum lifting capacity of 1000 lb (453 kg) under the inner four braces (1) and behind the center cross support above the wind shield or install two lifting eye bolts (2) in the threaded holes on the roof of the cab above the B pillars (3).
- Enclosed Cab: Install two lifting eye bolts (2) in the threaded holes on the roof of the cab above the B pillars (3).



Cab and Covers

- Use a hoist or overhead crane and sling attached to the cab. Carefully begin to align the cab with the mounting holes in the frame. Stop and check that wiring, hydraulic hoses, cables, etc., will not be pinched or damaged as the cab is positioned. Readjust the position of the sling as needed to help balance the cab during installation.

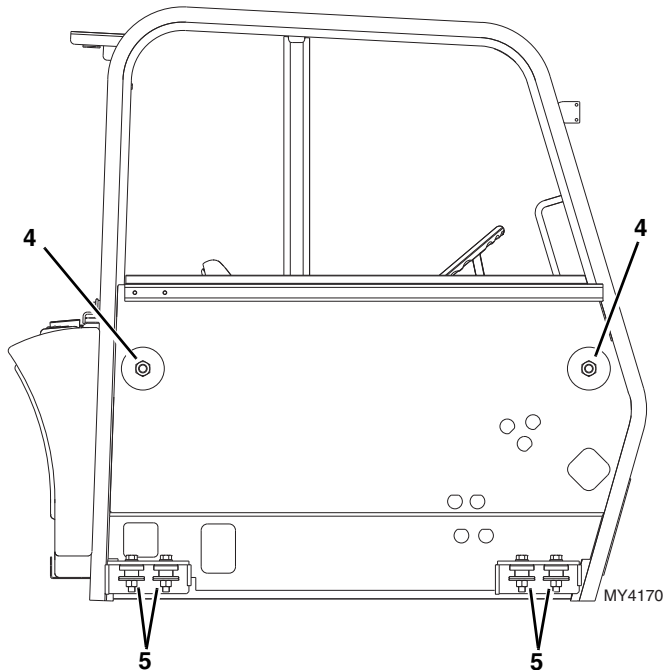

- Install the four cab-to-frame mount bolts, washers and nuts (5). Torque to 280-305 lb-ft (379-414 Nm).
 - Install the two cab side mount bolts washers and nuts (4). Torque to 680-720 lb-ft (922-976 Nm).
 - Install the engine air filter and hydraulic oil reservoir breather to their brackets at the top of the cab.
 - Install the throttle cable to the throttle pedal assembly. Refer to Section 4.3.3, "Throttle Pedal."
 - Pull all the hydraulic hoses and electrical wires through the cab.
 - Uncap and reconnect the previously labeled hydraulic hoses to their appropriate locations.
 - Reconnect the previously labeled electrical connections to their appropriate locations.
 - For machines equipped with the heater option, reconnect the heater hoses to the cab heater. Refer to Section 4.3.7, "Heater/Air Conditioning System (if equipped)."
 - Install the fuel tank to the cab. Refer to Section 7.6.2, "Fuel Tank."
 - Fill the cooling system completely with coolant, allowing time for the coolant to fill the engine block. The cooling system capacity is listed in Section 2.4, "Fluids and Lubricant Capacities."
 - Properly connect the battery.
 - Start the engine and check the operation of all controls. Check for hydraulic fluid leaks. Check the hydraulic fluid level in the tank and add fluid as required.
- Note:** When the engine is initially started, run it briefly at low idle and check the machine for any visual sign of fluid leakage. STOP the engine immediately if any leakage is noted, and make any necessary repairs before continuing.
- Wait for the engine to cool and check the coolant level. Add coolant to the overflow bottle as required to bring the coolant to the proper level.
 - Install the mirrors and all other cab components as needed, if removed.
 - Close and secure the engine cover.
 - Unblock the wheels.
 - Remove the Do Not Operate Tags from both the ignition key switch and the steering wheel.

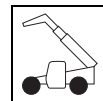

Section 5

Axles, Drive Shafts, Wheels and Tires

Contents

PARAGRAPH	TITLE	PAGE
5.1	Axles, Drive Shafts, Wheels and Tires Component Terminology	5-2
5.2	General Information	5-3
5.3	Axle Assemblies	5-3
5.3.1	Axle Serial Number Plate	5-3
5.3.2	Axle Specifications	5-3
5.3.3	Axle Internal Service	5-3
5.3.4	Axle Maintenance	5-3
5.3.5	Axle Removal	5-4
5.3.6	Axle Installation	5-4
5.3.7	Axle Assembly and Drive Shaft Troubleshooting	5-6
5.4	Drive Shafts	5-9
5.4.1	Drive Shaft Inspection and Service	5-9
5.4.2	Drive Shaft Maintenance	5-9
5.4.3	Drive Shaft Removal	5-9
5.4.4	Drive Shaft Cleaning and Drying	5-9
5.4.5	Drive Shaft Installation	5-9
5.5	Wheels and Tires	5-10
5.5.1	Removing Wheel and Tire Assembly from Machine	5-10
5.5.2	Installing Wheel and Tire Assembly onto Machine	5-11
5.6	Brakes	5-11
5.7	Towing a Disabled machine	5-11
5.7.1	Manually Releasing the Park Brake	5-11
5.7.2	Manually Resetting the Park Brake	5-12

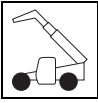

5.1 AXLES, DRIVE SHAFTS, WHEELS AND TIRES COMPONENT TERMINOLOGY

To understand the safety, operation and maintenance information presented in this section, it is necessary that the operator/mechanic be familiar with the names and locations of the major assemblies of the axles, drive shafts, wheels and tires. The following illustration identifies the components that are referred to throughout this section.

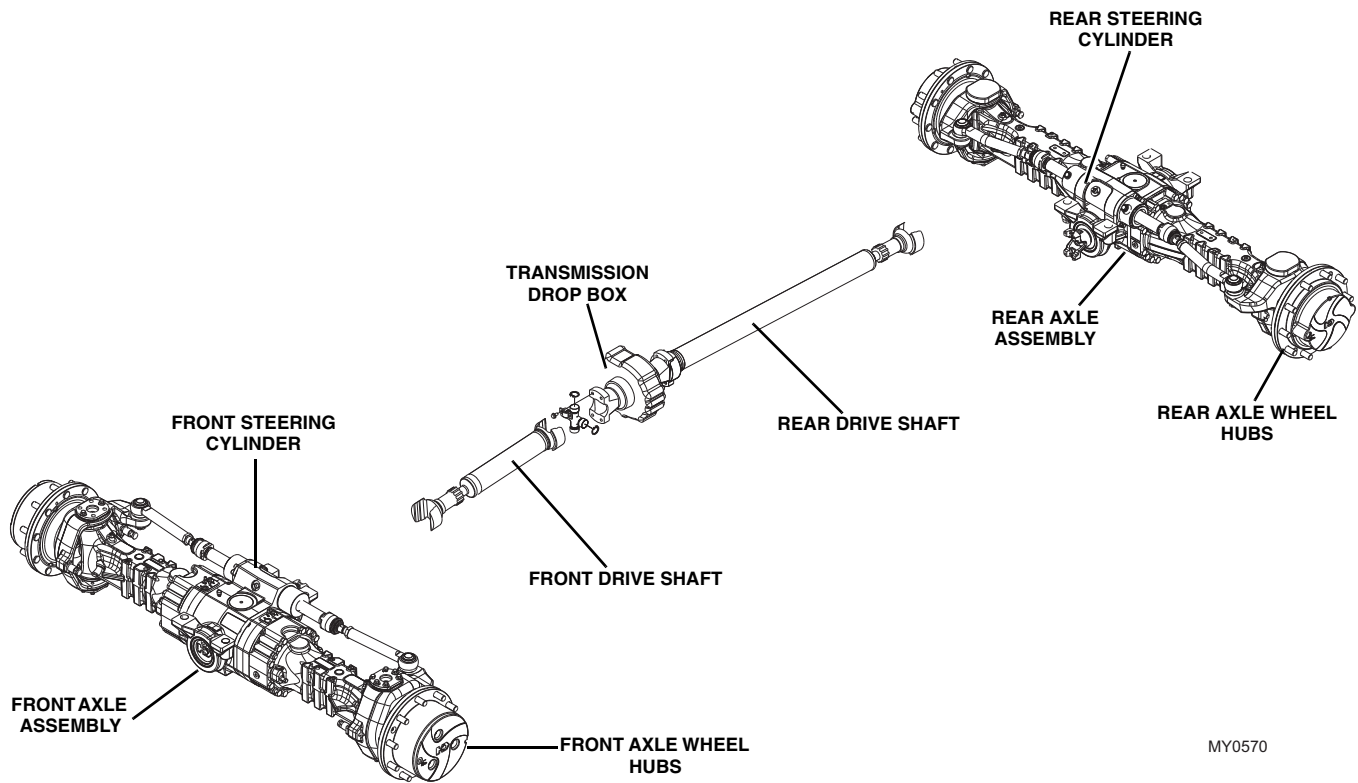



5.2 GENERAL INFORMATION

WARNING

DO NOT service the machine without following all safety precautions as outlined in Section 1, “Safety Practices,” of this manual.

Note: To help ensure optimum performance, the drive shaft assemblies are specially balanced as a unit at the factory. When servicing any flange yoke, slip yoke or drive shaft tube, order a complete assembly if components are bent or damaged. Refer to the appropriate parts manual for ordering information.

Before performing any inspection, maintenance or service operation, thoroughly clean the unit. The axles and drive shafts should be checked and repaired only by experienced service technicians who are aware of all safety instructions and particular component features.

Use suitable products to thoroughly clean all disassembled mechanical parts to help prevent personal injury to the worker and prevent damage to the parts. Carefully inspect the integrity of all moving parts (bearings, yokes, tubes, gears, shafts, etc.) and fasteners (nuts, bolts, washers, etc.) as they are subject to major stress and wear. Always replace any damaged, worn, cracked, seized or otherwise improper parts that could affect the safe and proper functioning of the machine, axles and drive shafts.

5.3 AXLE ASSEMBLIES

5.3.1 Axle Serial Number Plate

The front and rear axle serial number plate is located on a mounting pad on the front side of the center section of each axle. Information on the serial number plate is required in correspondence regarding the axle.

Supply information from the axle serial number plate when communicating about an axle assembly or axle components.

5.3.2 Axle Specifications

General axle specifications are found in Section 2.4, “Fluids and Lubricant Capacities.”

5.3.3 Axle Internal Service

Detailed axle service instructions (covering the axle, differential, brakes and wheel-end safety, repair, disassembly, reassembly, adjustment and troubleshooting information) are provided in the following manuals:

TL642

- P/N 31200162 (MFG P/N MO212S20)

TL943

- P/N 31200239 (MFG P/N MO223S10)

5.3.4 Axle Maintenance

CLEANING: Clean parts with machined or ground surfaces (such as gears, bearings and shafts) with emulsion cleaners or petroleum-based cleaners. **DO NOT** steam clean internal components and the interior of the planetary hub and axle housing. Water can cause corrosion of critical parts. Rust contamination in the lubricant can cause gear and bearing failure. Remove old gasket material from all surfaces.

DRYING: Use clean, lintless towels to dry components after cleaning. **DO NOT** dry bearings by spinning them with compressed air; this can damage mating surfaces due to lack of lubrication. After drying, lightly coat components with oil or a rust-preventive chemical to help protect them from corrosion. If storing components for a prolonged period, wrap them in wax paper.

PERIODIC OPERATION REQUIREMENT: Every two weeks, drive the machine far enough to cause the drive-train components to make several complete revolutions. This will help ensure that internal components receive lubrication to minimize deterioration caused by environmental factors such as high humidity.

SUBMERSION: If the machine has been exposed to water deep enough to cover the hubs, disassemble the wheel ends and inspect for water damage and contamination. If the carrier housing was submerged in water, especially if the water level was above the vent tube (breather), drain the axle and inspect internal parts for water damage and contamination. Before assembling and refilling the unit with the specified lubricant(s), clean, examine and replace damaged parts as necessary.

Note: Use a suitable puller for bearing removal. Clean, inspect and lubricate all bearings just prior to reassembly. If replacement of a damaged bearing cup or cone is necessary, replace the cup and cone as a set.

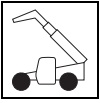

5.3.5 Axle Removal

The front and rear axle assemblies differ in that the front axle assembly is equipped with a parking brake mechanism and a limited-slip feature; the rear axle has neither. The following steps outline a typical axle removal procedure, suitable for either the front or the rear axle assembly.

Cleanliness is extremely important. Before attempting to remove the axle, thoroughly clean the machine. Avoid spraying water or cleaning solution on electrical components. If using a steam cleaner, seal all openings before steam cleaning.

Note: Clear the work area of all debris, unnecessary personnel, etc. Allow sufficient space to raise the machine and to remove the axle.

1. Park the machine on a firm, level surface, level the machine, fully retract the boom, lower the boom, place the travel select lever in the (N) NEUTRAL position, engage the parking brake, straighten all wheels and shut the engine OFF.
2. Place a Do Not Operate Tag on both the ignition key switch and steering wheel, stating that the machine should not be operated.
3. Open the engine cover. Allow the system fluids to cool.
4. Properly disconnect the battery.
5. Block the front and rear of both tires on the axle that is not being removed. Ensure that the machine will remain in place during axle removal before proceeding.
6. Raise the machine using a suitable jack or hoist. Place suitable supports under both sides of the frame and lower the machine onto the supports. Ensure that the machine will remain in place during axle removal.
7. Remove both wheel and tire assemblies from the axle that is being removed. (Refer to Section 5.5.1, "Removing Wheel and Tire Assembly from Machine.")

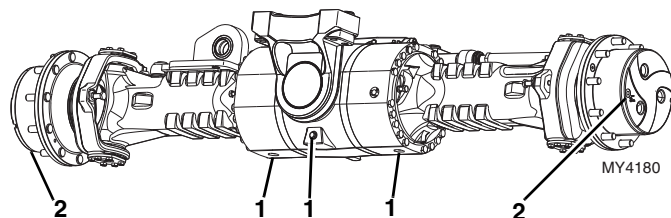

8. Place a suitable receptacle under the axle drain plugs (1) and wheel hubs drain plugs (2). Remove the drain plugs and allow the axle oil to drain into the receptacle. If necessary, rotate both wheel hubs and allow the wheel hub oil to drain into the receptacle.
9. Transfer the used oil into a suitable covered container, and label the container as "Used Oil." Dispose of used oil at an approved recycling facility.
10. Label, disconnect and cap the steering and brake lines at the axle. Wipe up any spilled oil.
11. Support the axle that is being removed with a suitable jack, hoist or overhead crane and sling. **DO NOT** raise the axle or the machine.

Note: The wheel and tire assemblies must be re-installed later with the directional tread pattern "arrows" facing in the direction of forward travel.

12. Remove the drive shaft assembly. Refer to Section 5.4.3, "Drive Shaft Removal."
13. On the front axle remove the capscrew and locknuts securing the lower position cylinder-mount pin to the front cylinder. Tap the cylinder mount pin out, and move the cylinder to prevent it from interfering with axle removal.
14. Remove the bolts and locknuts securing the axle to the frame.
15. Remove the axles from the machine using the jack, hoist or overhead crane and sling supporting the axle. **DO NOT** raise or otherwise disturb the machine while removing the axle. Balance the axle and prevent it from tipping, turning or falling while removing it from beneath the machine. Place the axle on a suitable support or holding stand.

5.3.6 Axle Installation

1. Before proceeding, ensure that the machine will remain in place during axle installation. Block the front and rear of both tires on the axle that is already installed on the machine.
2. If applicable, raise the machine using a suitable jack or hoist. Place suitable supports beneath the frame and lower the machine onto the supports, allowing enough room for axle installation. Ensure that the machine will remain in place during axle installation.

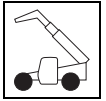

3. Using a suitable jack, hoist or overhead crane and sling, remove the axle from its support or holding stand. Balance the axle and prevent it from tipping, turning or falling while positioning it beneath the machine. **DO NOT** raise or otherwise disturb the machine while installing the axle. Keep the axle supported and balanced on the jack, hoist or overhead crane and sling throughout the installation procedure.
4. Position the axle under the frame, and align the axle housings with the holes in the frame.
5. Install the four axle bolts and nuts. Tighten and torque to 340-365 lb-ft (460-495 Nm) on the TL642. Torque bolts to 530-560 lb-ft (718-759 Nm) on the TL943.
6. Move the cylinder into position on the axle cylinder anchor. Insert a cylinder-mount pin through the cylinder and cylinder anchor. Secure the cylinder-mount pin with one capscrew and a new locknut.
7. Apply multi-purpose grease through the self-tapping lube fitting to lubricate the self-align bearing and the cylinder-mount pin.
8. Install the drive shaft assemblies. (Refer to Section 5.4.5, "Drive Shaft Installation.")
9. If reinstalling an axle previously removed from the machine, position the driveshaft yoke on the axle according to the alignment marks made earlier. If installing a new axle, note the position of the driveshaft yoke at the transmission. Align the driveshaft yoke on the axle in the same plane as the yoke on the transmission.

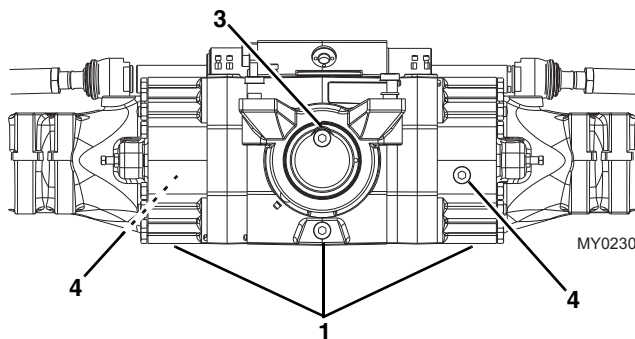

10. Tighten the axle oil drain plugs (1), loosen and remove the axle oil fill plug (3) and sight plugs (4). (Refer to Section 2.4, "Fluids and Lubricant Capacities," for proper oil and capacities.)

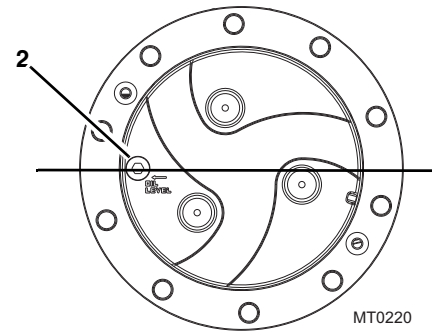

11. Rotate wheel hubs 90 degrees so the drain plug becomes the fill plug (2). Refer to Section 2.4, "Fluids and Lubricant Capacities," for proper oil and capacities.
12. Install the wheel and tire assemblies. Refer to Section 5.5.2, "Installing Wheel and Tire Assembly onto Machine."
13. Carefully remove the jack, hoist or overhead crane and sling supporting the axle.
14. Carefully raise the machine using a suitable jack or hoist. Remove the supports from beneath the frame and lower the machine to the ground.
15. Remove the blocks from the front and rear of both tires on the other axle.

Note: ALWAYS use new o-rings when servicing the machine.

16. Install new o-rings into the fittings. Lubricate the o-rings with clean hydraulic oil.
17. Uncap and connect the steering and brake lines at their axle fittings.
18. Check the hydraulic reservoir oil level.
19. Start the engine. Turn the steering wheel several times lock to lock, operate the frame tilt function several times in both directions and check the function of the brakes. Check for hydraulic leaks, and tighten or repair as necessary.

Note: The service brake circuit will need to be bled after axle installation. Refer to Section 8.7.3, "Brake Test."

20. Close and secure the engine cover.
21. Remove the Do Not Operate Tags from both the ignition key switch and the steering wheel.



Axles, Drive Shafts, Wheels and Tires

5.3.7 Axle Assembly and Drive Shaft Troubleshooting

Problem	Cause	Remedy
1. Excessive axle noise while driving.	1. Oil level too low.	1. Fill oil to correct level. Refer to Section 2.4, "Fluids and Lubricant Capacities."
	2. Axle and/or wheel end housings filled with incorrect oil or oil level low.	2. Drain axle and/or wheel end housings and fill to correct level with hydraulic oil. Refer to Section 2.4, "Fluids and Lubricant Capacities."
	3. Incorrect alignment of ring and pinion gears.	3. Correct alignment by adding or removing shims as needed.
	4. Incorrect pinion (input) shaft bearing preload.	4. Correct bearing preload by adding or removing shims as needed.
	5. Worn or damaged bearings.	5. Replace bearings as needed.
	6. Worn or broken gear teeth.	6. Replace gears as needed.
	7. Contamination in the axle.	7. Drain axle and/or wheel end housings and fill to correct level with hydraulic oil. Refer to Section 2.4, "Fluids and Lubricant Capacities."
	8. Axle housing damaged.	8. Replace damaged parts.
2. Intermittent noise when traveling.	1. Universal joint(s) worn or damaged.	1. Repair or replace universal joints as needed.
	2. Differential ring and/or pinion gears damaged.	2. Determine cause and repair as needed.
3. Vibration or intermittent noise when traveling.	1. Drive shaft universal joint assembly(ies) incorrectly tightened.	1. Tighten capscrews to correct torque.
	2. Drive shaft universal joint(s) worn or damaged.	2. Repair or replace universal joints as needed.
	3. Drive shaft(s) damaged/unbalanced.	3. Replace drive shaft(s) as needed.

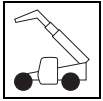

Problem	Cause	Remedy
<p>4. Oil leaking from axle (differential housing and/or axle housings).</p>	<ol style="list-style-type: none"> 1. Drain and/or inspection plugs loose and/or o-rings damaged or missing. 2. Hose fittings loose. 3. Axle shaft seal damaged or missing and/or worn or damaged shaft sealing surfaces. 4. Input shaft multi-seal ring damaged or missing and/or worn or damaged pinion (input) shaft sealing surfaces. 5. Axle casing to brake housing and/or brake housing to differential assembly o-rings and/or seals worn or damaged. 6. Axle housing mounting nuts and capscrews loose. 7. Differential and/or axle housing(s) damaged. 	<ol style="list-style-type: none"> 1. Replace o-rings as needed and tighten plugs to 130 Nm (96 lb-ft). 2. Tighten fittings. 3. Replace seal and/or joint coupling fork shaft (axle shaft). 4. Replace o-rings as needed and tighten plugs to 96 lb-ft (130 Nm). 5. Replace o-rings and seals. 6. Tighten housing nuts and capscrews to 390 Nm (288 lb-ft). 7. Replace housing(s) as needed.
<p>5. Oil leaking from wheel end housing (planet carrier).</p>	<ol style="list-style-type: none"> 1. Oil level plugs loose and/or o-rings damaged or missing. 2. O-ring between hub and housing (planet carrier) damaged or missing. 3. Shaft seal damaged or missing and/or worn or damaged shaft sealing surfaces. 4. Housing capscrews loose. 5. Housing (planet carrier) damaged. 	<ol style="list-style-type: none"> 1. Replace o-rings as needed and tighten plugs to 130 Nm (96 lb-ft). 2. Replace o-ring. 3. Replace seal and/or fork joint shaft. 4. Tighten housing capscrews to 55 Nm (41 lb-ft). 5. Replace housing (planet carrier).
<p>6. Oil leaking from steering cylinder.</p>	<ol style="list-style-type: none"> 1. Hose fittings loose. 2. Steering cylinder o-rings and/or seals worn or damaged. 3. Piston rod seal worn or damaged. 4. Cylinder tube damaged. 	<ol style="list-style-type: none"> 1. Tighten fittings. 2. Replace o-rings and seals. 3. Replace piston rod seal. 4. Replace cylinder tube.

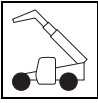

Axles, Drive Shafts, Wheels and Tires

Problem	Cause	Remedy
7. Axle overheating.	<ol style="list-style-type: none"> 1. Oil level too high. 2. Axle and/or wheel end housings filled with incorrect oil or oil contaminated or oil level low. 3. Dragging park brake. 	<ol style="list-style-type: none"> 1. Fill oil to correct level with hydraulic oil. Refer to Section 2.4, "Fluids and Lubricant Capacities." 2. Drain axle and fill to correct level with hydraulic oil. Refer to Section 2.4, "Fluids and Lubricant Capacities." 3. Adjust park brake cable as needed.
8. High steering effort required.	<ol style="list-style-type: none"> 1. Steering (hydraulic) system not operating properly. 2. Excessive joint housing swivel bearing preload. 3. Worn or damaged swivel bearings. 	<ol style="list-style-type: none"> 1. Refer to Section 8.4, "Hydraulic Circuits." 2. Correct bearing preload by adding or removing shims as needed. 3. Replace swivel bearings as needed.
9. Slow steering response.	<ol style="list-style-type: none"> 1. Steering (hydraulic) system not operating properly. 2. Steering cylinder leaking internally. 	<ol style="list-style-type: none"> 1. Refer to Section 8.4, "Hydraulic Circuits." 2. Repair or replace steering cylinder as needed.
10. Excessive noise when brakes are engaged.	<ol style="list-style-type: none"> 1. Brake discs worn. 2. Brake discs damaged. 	<ol style="list-style-type: none"> 1. Check brake discs for wear. Refer to Section 2.4, "Fluids and Lubricant Capacities." 2. Replace brake discs.
11. Brakes will not engage.	<ol style="list-style-type: none"> 1. Brake (hydraulic) system not operating properly. 2. Brake piston o-rings and seals damaged (leaking). 	<ol style="list-style-type: none"> 1. Refer to Section 8.7.3, "Brake Test." 2. Replace o-rings and seals.
12. Brakes will not hold the machine or braking power reduced.	<ol style="list-style-type: none"> 1. Brake discs worn. 2. Brake (hydraulic) system not operating properly. 3. Brake piston o-rings and seals damaged (leaking). 	<ol style="list-style-type: none"> 1. Check brake discs for wear. Refer to Section 5.3.3, "Axle Internal Service." 2. Refer to Section 8.7.3, "Brake Test." 3. Replace o-rings and seals.

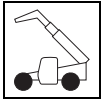

5.4 DRIVE SHAFTS

5.4.1 Drive Shaft Inspection and Service

Whenever servicing the machine, conduct a visual inspection of the drive shafts and cross and bearing assemblies (universal joints, or U-joints). A few moments spent doing this can help prevent further problems and down time later.

Inspect areas where the drive shaft flange yokes and slip yokes mount to the drive shafts. Attempt to turn each drive shaft in both directions. Look for excessive looseness, missing parts, cracks or other damage. Worn or damaged drive shafts and cross and bearing assemblies may cause an excessive amount of vibration or noise.

Note: Any bolt removed from the drive shaft assembly **MUST** be replaced. Do Not re-torque.

5.4.2 Drive Shaft Maintenance

Refer to Section 2.4, “Fluids and Lubricant Capacities,” for information regarding the lubrication of the grease fittings on the drive shafts.

5.4.3 Drive Shaft Removal

1. Park the machine on a firm, level surface, level the machine, fully retract the boom, lower the boom, place the transmission control lever in (N) NEUTRAL, engage the park brake and shut the engine OFF.
2. Place a Do Not Operate Tag on both the ignition key switch and steering wheel, stating that the machine should not be operated.
3. Open the engine cover. Allow the system fluids to cool.
4. Properly disconnect the battery.
5. Block the wheels.
6. The drive shaft assembly is a balanced assembly. Mark the yoke and axle, transmission and the shaft and slip yoke so that these components can be returned to their original positions when reinstalled. Yokes at both ends of the drive shaft must be in the same plane to help prevent excessive vibration.

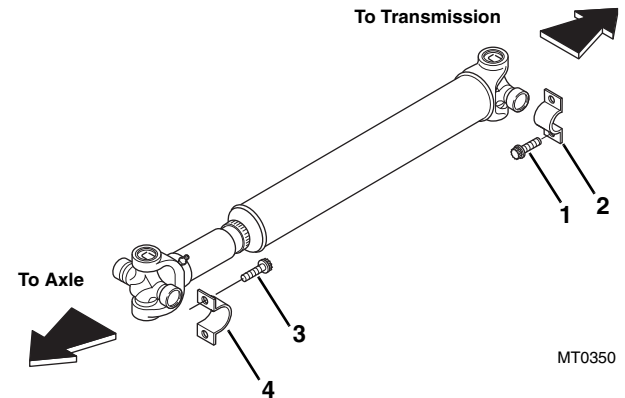

7. Remove the four bolts (1) and two straps (2) securing the bearing cross to the transmission output shaft flange. Discard bolts.
8. Remove the four bolts (3) and two straps (4) securing the bearing crosses to the axle. Discard bolts.
9. Remove the front drive shaft assembly.
10. Repeat the above procedure on the rear drive shaft.

5.4.4 Drive Shaft Cleaning and Drying

1. Disassemble and clean all parts using an approved cleaning fluid. Allow to dry.
2. Remove any burrs or rough spots from all machined surfaces. Re-clean and dry as required.

5.4.5 Drive Shaft Installation

1. Raise the drive shaft assembly into position. The slip-yoke end of the drive shaft mounts toward the axle. If reinstalling a drive shaft previously removed, align the flange yokes according to the alignment marks made during removal.
2. Apply Loctite® 243™ to all mounting bolts.
3. Install the two straps (2) and four new bolts (1) securing the bearing crosses to the transmission. Torque bolts to 55-60 lb-ft (75-81 Nm).
4. Install the two straps (2) and four new bolts (1) securing the bearing crosses to the axle. Torque bolts to 55-60 lb-ft (75-81 Nm).
5. Repeat the above procedure on the rear drive shaft.
6. Properly connect the battery.
7. Close and secure the engine cover.
8. Unblock the wheels.
9. Remove the Do Not Operate Tags from both the ignition key switch and the steering wheel.

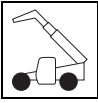

5.5 WHEELS AND TIRES



WARNING

Mismatched tire sizes, ply ratings or mixing of tire types (radial tires with bias-ply tires) may compromise machine stability and may cause machine to tip over.

It is recommended that a replacement tire to be the same size, ply and brand as originally installed. Refer to the appropriate parts manual for ordering information. If not using an approved replacement tire, it is recommended that replacement tires have the following characteristics:

- Equal or greater ply/load rating and size of original.
- Tire tread contact width equal or greater than original.
- Wheel diameter, width and offset dimensions equal to the original.
- Approved for the application by the tire manufacturer (including inflation pressure and maximum tire load).

The rims installed have been designed for stability requirements which consist of track width, tire pressure and load capacity. Size changes such as rim width, center piece location, larger or smaller diameter, etc., without written factory recommendations, may result in unsafe condition regarding stability.

Foam filled tires have a positive effect on the weight, stability and handling characteristics of the machine, especially under load. The use of hydrofill as a tire-fill substance is not recommended because of possible environmental impact.

Large-bore valve stems are used to help expedite tire inflation and deflation. An inner tube may be used if a tire does not provide an airtight seal. Check tire inflation pressures when the tires are cold. When mounting a tire on the wheel, the tire must be mounted on the wheel respective of the directional tread pattern of the tire; this produces a left or right tire and wheel assembly.

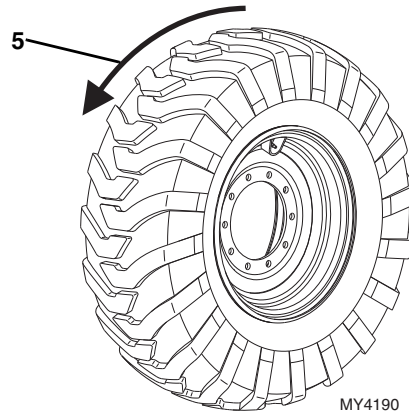

The wheel and tire assemblies must be installed with the directional tread pattern “arrows” (5) facing in the direction of forward travel.

5.5.1 Removing Wheel and Tire Assembly from Machine

1. Park the machine on a firm, level surface, fully retract the boom, lower the boom, place the transmission control lever in (N) NEUTRAL, engage the park brake and shut the engine OFF.
2. Place an Do Not Operate Tag on both the ignition key switch and steering wheel, stating that the machine should not be operated.
3. Loosen but **DO NOT** remove the lug nuts on the wheel and tire assembly to be removed.
4. Place a suitable jack under the axle pad closest to the wheel being removed. Raise the machine and position a suitable support beneath the axle. Allow sufficient room to lower the machine onto the support and to remove the wheel and tire assembly.
5. Lower the machine onto the support.
6. Remove lug nuts and lug washers in an alternating pattern.
7. Remove the wheel and tire assembly from the machine.

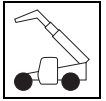

5.5.2 Installing Wheel and Tire Assembly onto Machine

Note: The wheel and tire assemblies must be installed with the directional tread pattern “arrows” facing in the direction of forward travel.

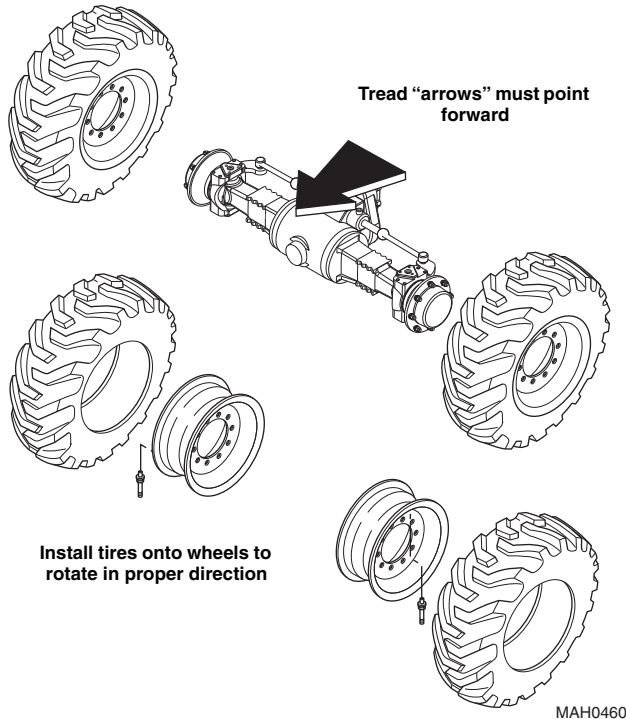

1. Position wheel onto studs on wheel end of axle.
2. Install wheel lug washers.
3. Start all nuts by hand to prevent cross threading. DO NOT use a lubricant on threads or nuts.

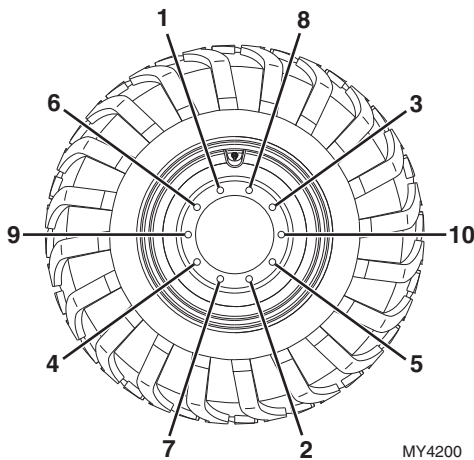

4. Tighten lug nuts in an alternating pattern as indicated in figure. Torque to 350-400 lb-ft (475-542 Nm).
5. Remove machine from supports.

6. Remove the Do Not Operate Tags from both the ignition key switch and the steering wheel.

5.6 BRAKES

Check the brake disks for wear every 1,000 hours of operation or yearly.

For more information on brake disk inspection, refer to the appropriate axle repair manual.

5.7 TOWING A DISABLED MACHINE

Towing a disabled machine should only be attempted as a last resort, after exhausting all other options. Make every effort to repair the machine, and move it under its own power, before using the emergency towing procedures outlined below.

Note: Block the wheels of the machine BEFORE attempting to release the park brake. Once the park brake is released the machine’s park brake AND service brakes are inoperable.

5.7.1 Manually Releasing the Park Brake

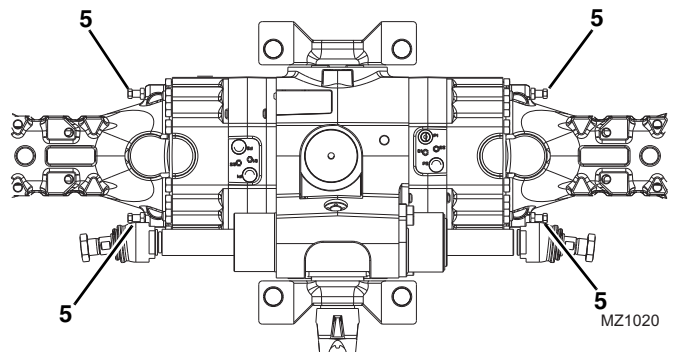

1. Loosen the nuts of the screws (5) for the manual release of the braking units. Draw the nuts back approximately 6 mm.
2. Tighten the screws until they are gently seated on the driving plate
3. Carefully tighten each release screw a 1/4 turn at a time in sequence until all have been turned on full turn 360°.
4. Repeat steps 1 thru 3 for the other side of the differential.

Note: After the machine has been towed to a secure location, reactivate the parking brake. Carefully follow the procedures from start to finish. Consult your local service distributor or service department if you are unsure about any part of the procedure, or for specific instructions concerning your particular situation.

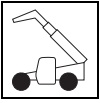

5.7.2 Manually Resetting the Park Brake

Note: Block the wheels of the machine **BEFORE** attempting to reset the machine's park brake. Once the park brake is released the machine's park brake **AND** service brakes are inoperable.

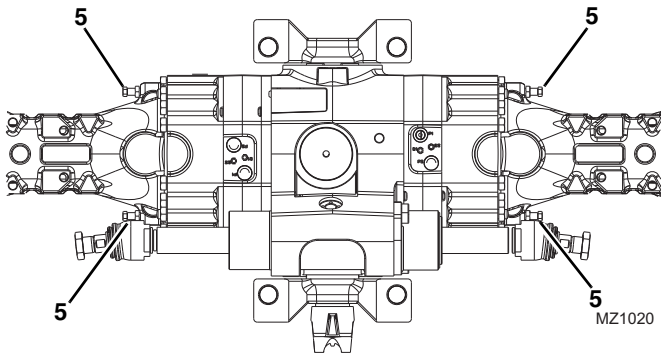

1. Loosen each release screw (5), only 1/4 turn at a time, in sequence, until each screw has lost contact with the guide pin.
2. Remove the screws along with the nuts and seals. Replace the seals, lubricate the screws with a silicone-based grease and re-install the screws along with the nuts.
3. Adjust the nut of the screw heads in relation to the arm by 1.26 in (32 mm).
4. Repeat steps 1 thru 3 for the other side of the differential.
5. After repairs to the machine have been made, start the machine and check the park brake and service brakes for proper function.



Section 6 Transmission

Contents

PARAGRAPH	TITLE	PAGE
6.1	Transmission Assembly Component Terminology	6-2
6.2	Transmission Serial Number	6-3
6.3	Transmission Specifications and Maintenance Information	6-3
6.4	Transmission Replacement	6-3
6.4.1	Transmission Removal	6-3
6.4.2	Transmission Inspection and Internal Repair	6-4
6.4.3	Transmission Installation	6-4
6.4.4	After Transmission Service or Replacement	6-5
6.5	Torque Converter Diaphragm	6-6
6.5.1	Torque Converter Diaphragm Removal	6-6
6.5.2	Torque Converter Diaphragm Installation	6-6
6.6	Troubleshooting	6-7
6.6.1	Transmission Troubleshooting	6-7



6.1 TRANSMISSION ASSEMBLY COMPONENT TERMINOLOGY

To understand the safety, operation and maintenance information presented in this section, it is necessary that the operator/mechanic be familiar with the names and locations of the major assemblies of the transmission. The following illustration identifies the components that are referred to throughout this section.

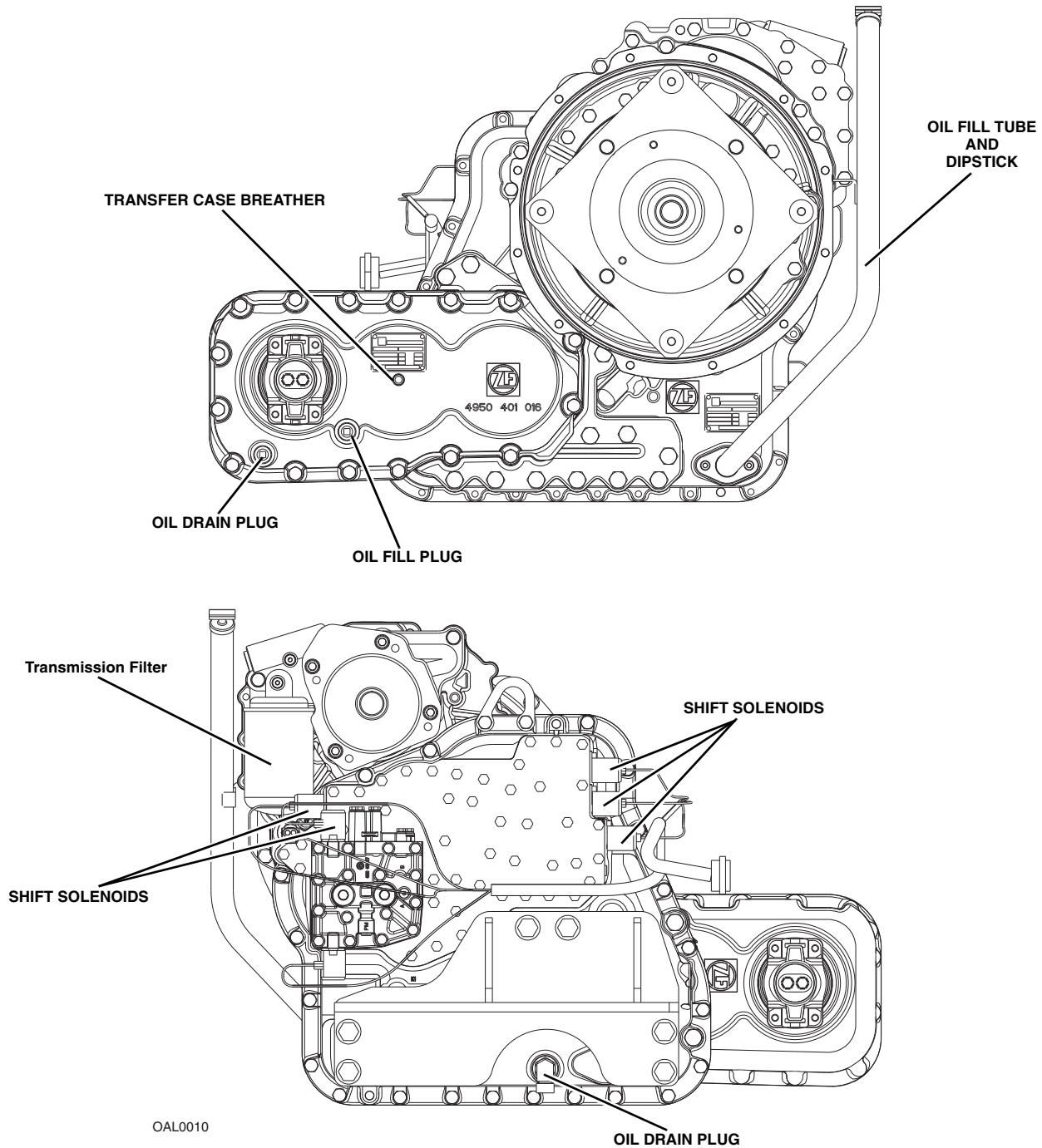



! WARNING

DO NOT service the machine without following all safety precautions as outlined in Section 1, “Safety Practices,” of this manual.

6.2 TRANSMISSION SERIAL NUMBER

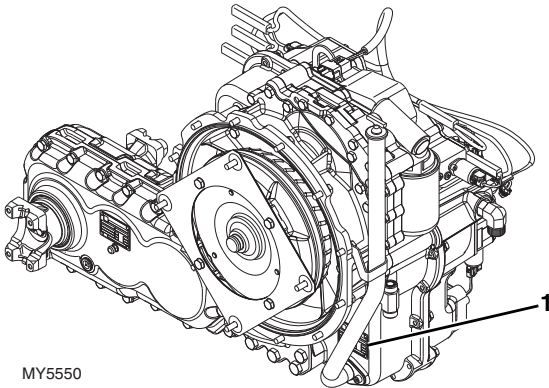

The transmission serial number plate is located on the front of the transmission behind the oil dipstick. Information on the serial number plate is required in correspondence regarding the transmission.

6.3 TRANSMISSION SPECIFICATIONS AND MAINTENANCE INFORMATION

For transmission, oil specifications and maintenance information, refer to Section 2, “General Information and Specifications.”

Detailed transmission service instructions are provided in the following publications:

- Service Manual (P/N 31200241)
- Parts Manual TL642 (P/N 31200255)
- Parts Manual TL943 (P/N 31200256)

6.4 TRANSMISSION REPLACEMENT

Note: Contact your local Service Department if internal transmission repair is required during the warranty period.

Note: Cleanliness is of extreme importance. Before attempting to remove the transmission, thoroughly clean the exterior of the transmission to help prevent dirt from entering during the replacement process. Avoid spraying water or cleaning solution onto or near the transmission shift solenoids and other electrical components.

6.4.1 Transmission Removal

! WARNING

NEVER lift a transmission alone; enlist the help of at least one assistant or use a suitable hoist or overhead crane and sling with a minimum lifting capacity of 1000 lb (454 kg).

1. Park the machine on a firm, level surface, level the machine, fully retract the boom, lower the boom, place the transmission control lever in (N) NEUTRAL, engage the park brake and shut the engine OFF.
2. Place a Do Not Operate Tag on both the ignition key switch and steering wheel, stating that the machine should not be operated.
3. Open the engine cover. Allow the system fluids to cool.
4. Remove engine cover to allow easier access to the transmission.
5. Drain the hydraulic oil reservoir. Refer to Section 8.5.1, “Hydraulic Oil Reservoir Draining.”
6. Properly disconnect the battery.
7. Thoroughly clean the transmission and surrounding area, including all hoses and fittings, before proceeding.

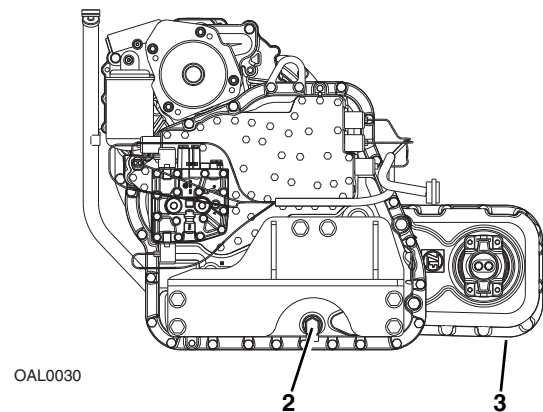

8. Place a suitable receptacle under the transmission drain plug (2). Remove the transmission drain plug, and allow the transmission oil to drain into the receptacle. Repeat drain procedure with the drop box (3).
9. Transfer the used transmission oil into a suitable, covered container, and label the container as “Used Oil.” Dispose of used oil at an approved recycling facility. Clean and reinstall the transmission drain plug.



Transmission

10. Remove the transmission-to-axle drive shafts. Refer to Section 5.4.3, "Drive Shaft Removal."
11. Remove air cleaner unit and intake tubes.
12. Remove the hydraulic pump. Refer to Section 8.6.1, "Pump Replacement."
13. Label and disconnect the transmission temperature switch connector and shift solenoid wiring harness connectors.
14. Label, disconnect and cap the transmission oil cooler inlet and outlet hoses at the transmission. The transmission oil cooler outlet hose, routed to the lower radiator fitting, is located on the top of the transmission. The transmission oil cooler inlet hose, routed to the upper radiator fitting, is located on top of the transmission.
15. Remove the access plug from side of the engine bell housing. This will allow access to remove the eight bolts holding the flex plate to the engine flywheel.
16. Turn the engine over slowly by hand and align each of the eight flex plate bolts to be accessed. Remove them one at a time.
17. Wipe up any spilled hydraulic and transmission oil.
18. Connect a lifting strap or chain to the lifting eye at the top of the transmission, and to a suitable hoist or overhead crane. Operate the hoist or crane to remove slack from the chain, but **DO NOT** raise the transmission at this time.
19. Place blocks under rear of engine for support **BEFORE** transmission mounts are removed.
20. Place blocks under the transmission to help support it during removal.
21. Remove both rear transmission mount bolts and lockwashers securing the transmission mount to the frame.
22. Remove the bolts and washers holding the transmission to the engine.
23. Remove the capscrews and lockwashers securing each rear transmission mount to the transmission.
24. Remove the transmission mounts from the machine.
25. Inspect the rubber mounts. Replace the mounts if damaged.
26. Carefully remove the transmission from the machine. Avoid causing damage to the transmission or surrounding parts.
27. Lift the transmission clear of the machine, and lower it onto suitable supports or secure it to a stand built especially for transmission or engine service. Secure the transmission so that it will not move or fall.

28. Remove any external transmission components as required, including the transmission temperature switch, and inlet and outlet cooler hose fittings. Cover all transmission openings.
29. Remove the transmission oil filter (3) and dispose of properly. Clean the filter mounting surface. Cover or cap the oil filter mount.
30. If transmission oil is suspect to contamination or torque converter is damaged, remove the converter and flex plate from the transmission.
31. Remove the bolt and washers holding the converter to the flex plate.

6.4.2 Transmission Inspection and Internal Repair

If replacing the entire transmission, transfer the transmission temperature switch to the replacement transmission. The gear shift solenoids are included with a new transmission.

6.4.3 Transmission Installation

WARNING

NEVER lift a transmission alone; enlist the help of at least one assistant or use a suitable hoist or overhead crane and sling with a minimum lifting capacity of 1000 lb (454 kg).

1. Install both rear transmission mounts on the transmission. Torque capscrews to 66 lb-ft (89 Nm).
2. Install two guide studs near the top of the bell housing holes.
3. Use a hoist or overhead crane and sling attached to the lifting eye at the top of the transmission. Raise and position the transmission within the chassis.
4. Align the torque converter, align the transmission bolt holes with the two studs in the bell housing. Install the eight bolts and washers and torque to 53 lb-ft (72 Nm). Remove the two alignment studs and install and torque the last two transmission mounting bolts.
5. Install the two rear transmission mounting bolts on the frame with two capscrews and two lockwashers. Apply Loctite® 242™ to the transmission mount bolts and torque to 220 lb-ft (298 Nm).
6. Turn the engine over slowly by hand and align each of the eight flex plate bolts to be accessed. Install them one at a time. Torque to 26-29 lb-ft (35-39 Nm). Replace access plug.



7. Remove the hoist or overhead crane and sling.
8. Connect the transmission temperature switch connector and shift solenoid wiring harness connectors.
9. Secure the wiring harness to the transmission housing.
10. Connect the transmission oil cooler inlet and outlet hoses at the transmission.
11. Install the hydraulic pump. Refer to Section 8.6.1, "Pump Replacement."
12. Install the transmission-to-axle drive shafts. Refer to Section 5.4.5, "Drive Shaft Installation."
13. Install the air cleaner and tubing.
14. Clean the transmission oil filter mounting surface.
15. Apply a thin film of clean hydraulic oil to the new transmission filter gasket. Install the new filter and torque to 20-25 lb-ft (27-34 Nm).

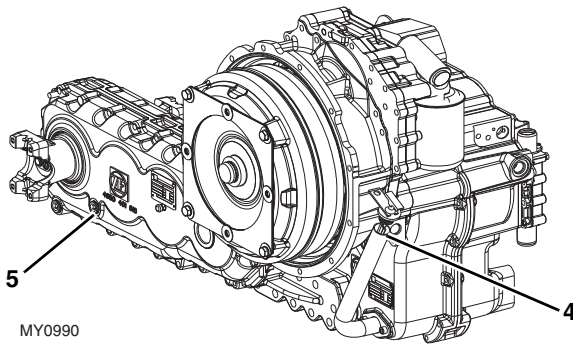

16. Transmission oil may be added through the dipstick tube (4). Remove the dipstick and add hydraulic oil. Check the oil level by taking intermittent dipstick readings as outlined in the appropriate Operation & Maintenance Manual. **DO NOT** overfill. Reinstall the dipstick when finished.
17. Transmission transfer case oil may be added through the fill plug (5). Remove the fill plug and add approximately 1.5 quarts (1,4 liters) hydraulic oil. Install fill plug and tighten.
18. Install the engine cover.
19. Properly connect the battery.
20. Close and secure the engine cover.
21. Remove the Do Not Operate Tags from both the ignition key switch and the steering wheel.

6.4.4 After Transmission Service or Replacement

In general:

1. Check the transmission oil level and add oil as required.
2. Disconnect and clean all transmission cooler hoses. When possible, remove transmission lines from the machine for cleaning.
3. Drain and flush the entire transmission cooling system.
4. Thoroughly clean transmission filter screens and cases, and replace transmission filter elements.
5. Reassemble all components and fill the transmission with clean, fresh hydraulic oil through the dipstick tube opening (4). Check the level by taking intermittent dipstick readings as outlined in the appropriate Operation & Maintenance Manual. **DO NOT** overfill. Reinstall the dipstick when finished.
6. Run the engine for two minutes at idle to help prime the torque converter and the transmission oil lines.
7. Recheck the level of the fluid in the transmission with the engine running at idle.
8. Add hydraulic oil as necessary to bring the fluid level up until it reaches the FULL mark on the dipstick. Recheck the oil level when it reaches operating temperature 180-200° F (83-94° C).
9. Recheck all drain plugs, lines, connections, etc., for leaks, and tighten where necessary.



6.5 TORQUE CONVERTOR DIAPHRAGM

6.5.1 Torque Converter Diaphragm Removal

1. Park the machine on a firm, level surface, level the machine, fully retract the boom, lower the boom, place the travel select lever in the (N) NEUTRAL position, engage the parking brake, and shut the engine OFF.

Note: In order to remove the engine drive plates, the engine and transmission must be separated.

2. Refer to Section 6.4.1, "Transmission Removal," or Section 7.9.1, "Engine Removal."

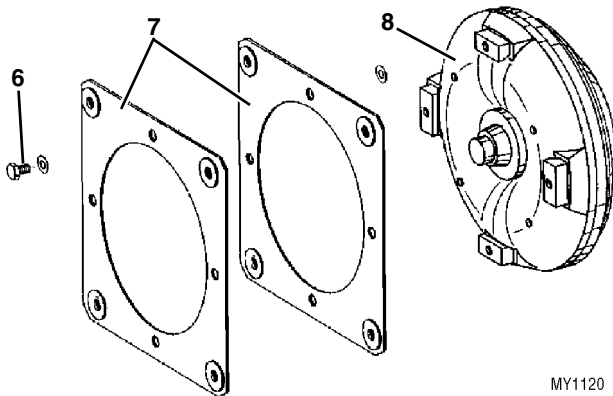

3. Remove the four bolts holding the diaphragms to the flywheel.
4. With the drive plates and torque converter removed, loosen and remove the four bolts (6) and eight lock washers holding the two diaphragms (7) to the torque converter (8).
5. Replace both diaphragms if damaged.

6.5.2 Torque Converter Diaphragm Installation

1. Install the two new diaphragms on the torque converter and install the four bolts with lock washers.
2. Mount the diaphragm/converter assembly to the transmission.
3. Refer to Section 6.4.3, "Transmission Installation," or Section 7.9.2, "Engine Installation," for the remainder of the installation.



6.6 TROUBLESHOOTING

This section provides an easy reference guide covering the most common problems that may occur during operation of the transmission.

Note: Contact your local Service Department if internal transmission repair is required during the warranty period.

The transmission should be checked, serviced and repaired only by experienced service technicians who are aware of all safety instructions and particular component features.

6.6.1 Transmission Troubleshooting

Problem	Cause	Remedy
1. Transmission will not engage or will not shift properly.	1. Oil level too high or low.	1. Fill transmission to correct level with hydraulic oil. Refer to Section 2.4, "Fluids and Lubricant Capacities."
	2. Transmission control lever not functioning properly and/or a fault in the wiring harness. Transmission control lever not functioning properly and/or a fault in the wiring harness.	2. Refer to Section 9.5, "Electrical System Schematics."
	3. Transmission valve body solenoids not functioning properly.	3. Refer to Section 9.5, "Electrical System Schematics."
	4. Pilot-operated shift valves not operating properly.	4. Clean the valve spool and housing. Replace return spring as needed.
	5. Pump output pressure low.	5. Refer to Section 6.6.1, "Transmission Troubleshooting," Problem 2. "Low or no pump flow or pressure."
	6. Clutch piston o-rings damaged.	6. Replace o-rings.
	7. Clutch discs worn or damaged.	7. Replace clutch discs.
	8. Coupling shafts or gear teeth damaged.	8. Replace couplings.



Transmission

Problem	Cause	Remedy
2. Low or no pump flow or pressure.	<ol style="list-style-type: none"> 1. Low oil level. 2. Transmission filled with incorrect oil, or oil contaminated. 3. Pump suction pipe screen clogged. 4. Central shaft damaged. 5. Pump worn or damaged. 	<ol style="list-style-type: none"> 1. Fill transmission to correct level with hydraulic oil. Refer to Section 2.4, "Fluids and Lubricant Capacities." 2. Drain transmission and fill to correct level with hydraulic oil. Refer to Section 2.4, "Fluids and Lubricant Capacities." 3. Clean, repair and/or replace suction pipe. 4. Replace central shaft. 5. Repair or replace pump assembly.
3. Low clutch pressure.	<ol style="list-style-type: none"> 1. Incorrect oil level. 2. Main pressure valve stuck open. 3. Broken or worn coupling shaft or piston o-rings. 4. Pressure reducing valve stuck open. 	<ol style="list-style-type: none"> 1. Fill transmission to correct level with hydraulic oil. Refer to Section 2.4, "Fluids and Lubricant Capacities." 2. Clean the valve spool and housing. 3. Replace coupling and/or o-rings. 4. Clean the valve spool and housing.
4. Lack of power.	<ol style="list-style-type: none"> 1. Park or service brake dragging. 2. Low engine rpm causes converter stall. 3. Pump output pressure is low. 4. Clutch discs worn or damaged. 5. Transmission overheating. 	<ol style="list-style-type: none"> 1. Refer to Section 8.4, "Hydraulic Circuits." 2. Adjust the engine rpm to specifications. Refer to Engine Service Manual. 3. Refer to Section 6.6.1, "Transmission Troubleshooting," Problem 2. "Low or no pump flow or pressure." 4. Replace clutch discs. 5. Refer to Section 6.6.1, "Transmission Troubleshooting," Problem 5. "Transmission overheating (oil above 248° F (120° C))."



Problem	Cause	Remedy
5. Transmission overheating (oil above 248° F (120° C)).	<ol style="list-style-type: none"> 1. Low oil level. 2. Clogged radiator. 3. Transmission filled with incorrect oil, or oil contaminated. 4. Excessive “roading.” 5. Restriction in oil cooler hoses. 6. Pump worn or damaged. 7. Engine thermostat stuck. 	<ol style="list-style-type: none"> 1. Fill transmission to correct level with hydraulic oil. Refer to Section 2.4, “Fluids and Lubricant Capacities.” 2. Remove debris from the radiator. 3. Drain transmission and fill to correct level with hydraulic oil. Refer to Section 2.4, “Fluids and Lubricant Capacities.” 4. Stop and idle the engine. 5. Replace cooler hoses. 6. Repair or replace pump assembly. 7. Replace engine thermostat. Refer to Section 7.4.2, “Thermostat Replacement.”
6. Grinding or “clunking” noise from transmission.	<ol style="list-style-type: none"> 1. Oil level too low. 2. Transmission filled with incorrect oil. 3. Incorrect clutch engagement. 4. Internal damage. 5. Broken drive plate. 6. Loose drive plate mounting capscrews. 	<ol style="list-style-type: none"> 1. Fill oil to correct level. Refer to Section 2.4, “Fluids and Lubricant Capacities.” 2. Drain transmission and fill to correct level with hydraulic oil. Refer to Section 2.4, “Fluids and Lubricant Capacities.” 3. Refer to Section 9.11.2, “Transmission Solenoid Valves.” 4. Repair or replace parts as needed. 5. Replace drive plate. Refer to Section 7.10, “Engine Drive Plate.” 6. Tighten capscrews.



Transmission

Problem	Cause	Remedy
7. Oil leaking from transmission.	<ol style="list-style-type: none">1. Oil leaking from vent (high oil level).2. Drain plug loose and/or o-rings damaged or missing.3. Hose fittings loose.4. Oil leaking at valve bodies (possible valve body gaskets damaged or missing and/or mounting capscrews not tight).5. Housing capscrews loose.6. Oil leaking at pump (possible pump-to-housing o-rings missing or damaged, and/or pump mounting capscrews not tight).7. Oil leaking at converter bell (possible converter leak and/or input shaft seal damage).8. Oil leaking at output shaft (output shaft seal damaged).9. Housing damaged.	<ol style="list-style-type: none">1. Remove drain plug and drain oil as needed, until oil is at correct level. Refer to Section 2.4, "Fluids and Lubricant Capacities." Replace o-rings as needed and tighten plugs to 130 Nm (96 lb-ft).2. Replace o-rings as needed and tighten plug to 35 Nm (26 lb-ft).3. Tighten fittings.4. Replace gaskets and/or tighten capscrews to 9,5 Nm (7 lb-ft).5. Tighten capscrews to 46 Nm (34 lb-ft).6. Replace o-rings and/or tighten capscrews to 115 Nm (85 lb-ft).7. Replace converter and/or input shaft seal.8. Replace output shaft seal.9. Replace housing as needed.



Section 7

Engine

Contents

PARAGRAPH	TITLE	PAGE
7.1	Introduction	7-2
7.1.1	Disclaimer and Scope	7-2
7.1.2	Component Terminology	7-3
7.2	Engine Serial Number	7-4
7.3	Specifications and Maintenance Information	7-4
7.4	Engine Cooling System	7-4
7.4.1	Radiator Pressure Cap	7-4
7.4.2	Thermostat Replacement	7-4
7.4.3	Radiator/Oil Cooler and Replacement	7-5
7.5	Engine Electrical System	7-6
7.6	Fuel System	7-7
7.6.1	Diesel Fuel	7-7
7.6.2	Fuel Tank	7-7
7.6.3	After Fuel System Service	7-8
7.7	Engine Exhaust System	7-8
7.7.1	Exhaust System Removal	7-8
7.7.2	Exhaust System Installation	7-9
7.8	Air Cleaner Assembly	7-9
7.8.1	Air Cleaner Assembly Removal	7-9
7.8.2	Air Cleaner Assembly Installation	7-9
7.8.3	Air Cleaner Assembly Removal	7-10
7.8.4	Air Cleaner Assembly Installation	7-10
7.9	Engine Replacement	7-10
7.9.1	Engine Removal	7-10
7.9.2	Engine Installation	7-11
7.10	Engine Drive Plate	7-13
7.10.1	Drive Plate Removal	7-13
7.10.2	Drive Plate Installation	7-13
7.11	Troubleshooting	7-14



Engine

7.1 INTRODUCTION

7.1.1 Disclaimer and Scope

These instructions are written for worldwide use. In territories where legal requirements govern engine smoke emission, noise, safety factors, etc., apply all instructions, data and dimensions provided herein in such a way that after maintenance, service and repair of the engine, engine operation does not violate local regulations.

Note: *These instructions cover only the routine maintenance, removal, installation and troubleshooting of the engine. Refer to the local Engine Distributor and the applicable Engine Service Manual for assistance with comprehensive engine diagnosis, repair and component replacement. A gradual running-in (break-in) of a new engine is not necessary. Full load can be applied to a new engine as soon as the engine is put into service and the coolant temperature is at least 140° F (60° C). Extended light-load operation during the early life of the engine is not recommended. **DO NOT** run the engine at high, no-load speeds. **DO NOT** apply an overload to the engine.*



7.1.2 Component Terminology

To understand the safety, operation and maintenance information presented in this section, it is necessary that the operator/mechanic be familiar with the names and locations of the engine components. The following illustration identifies the components that are referred to throughout this section.

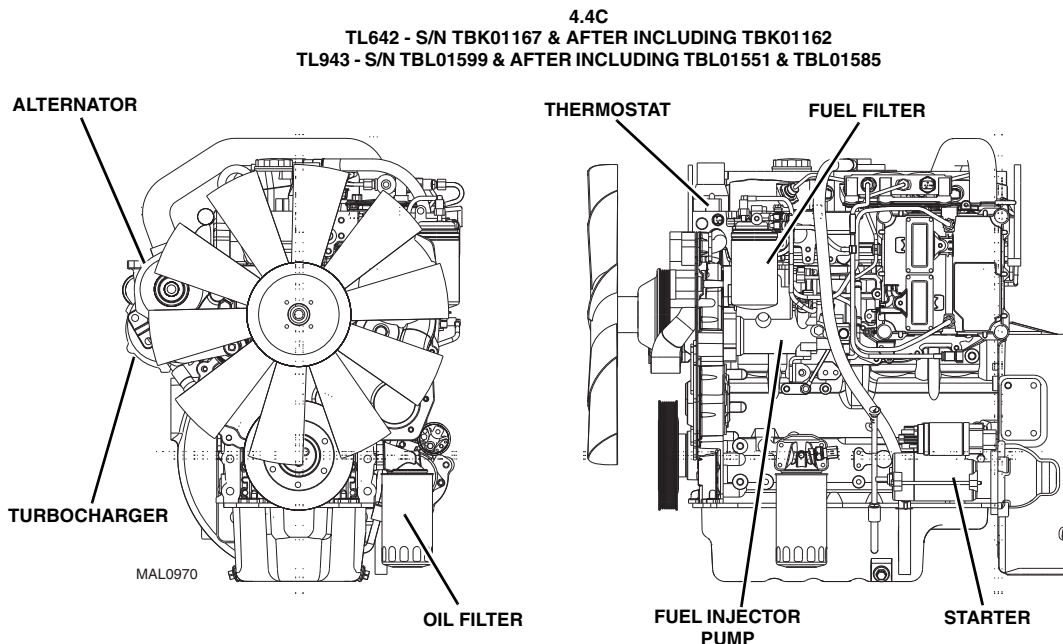
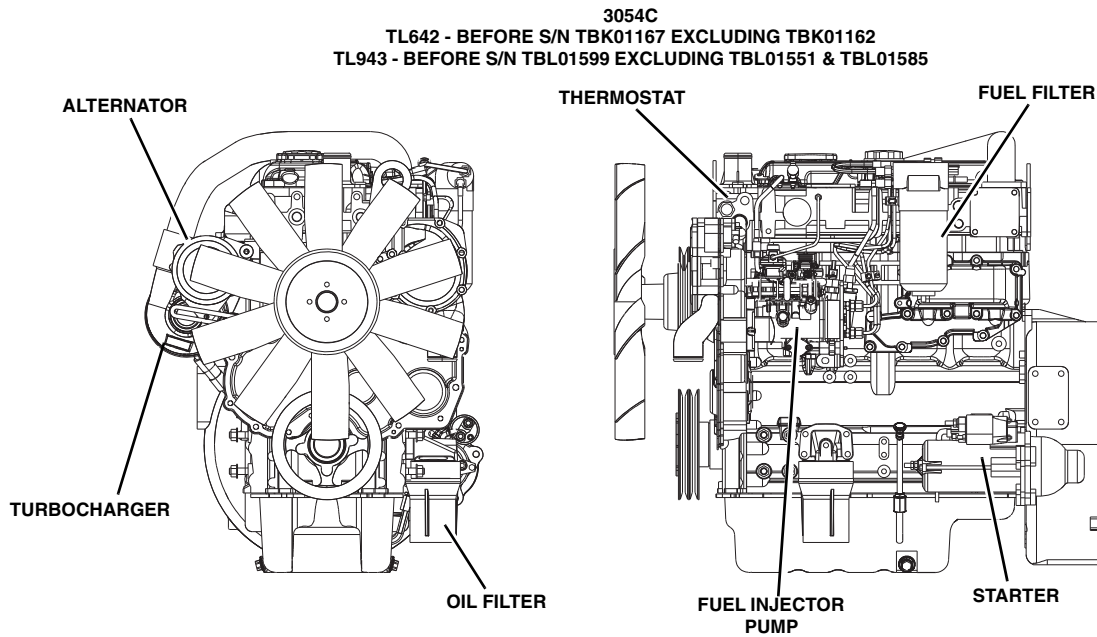



Engine

7.2 ENGINE SERIAL NUMBER

The CAT 3054C and C4.4 serial number is stamped on top of the engine. Information contained in the serial number is required in correspondence with the engine manufacturer.

7.3 SPECIFICATIONS AND MAINTENANCE INFORMATION

For engine, coolant and oil specifications, and maintenance information, refer to Section 2, "General Information and Specifications."

Detailed engine service instructions are provided in the following publications:

TL642 - Before S/N TBK01167 excluding TBK01162

TL943 - Before S/N TBL01599 excluding TBL01551 & TBL01585

- Operation & Maintenance Manual (P/N SEBU7655)
- Specifications (P/N RENR2437)
- System Operation Testing and Adjusting (P/N RENR2438)
- Disassembly and Assembly (P/N RENR2433)
- Parts Manual (P/N SEBP3644)
- Service Manual (P/N RENR2435)

TL642 - S/N TBK01167 & After including TBK01162

TL943 - S/N TBL01599 & After including TBL01551 & TBL01585

- Operation & Maintenance Manual (P/N SEBU8180)
- Specifications (P/N RENR9961)
- System Operation Testing and Adjusting (P/N RENR9965)
- Disassembly and Assembly (P/N KENR6216)
- Parts Manual (P/N SEBP4124)
- Schematic - Electrical (P/N RENR9964)
- Troubleshooting (P/N SENR9969)
- Torque Specifications (SENR 3130)

7.4 ENGINE COOLING SYSTEM

7.4.1 Radiator Pressure Cap

For a 99° C (210° F) system, use a 90 kPa (13 psi) radiator cap. An incorrect or malfunctioning cap can result in the loss of coolant and a hot-running engine.

7.4.2 Thermostat Replacement

Before considering thermostat replacement, check the coolant level, fan belt tension and instrument cluster temperature indicator.

- If the engine seems to take a long time to warm up, the thermostat may be stuck in the open position and requires replacement.
- If the engine runs hot, check the temperature of the upper radiator hose.
- If the hose is not hot, the thermostat may be stuck in the closed position.
- If the engine has overheated, performance may suffer, indicating other damage including a leaking cylinder head gasket, cracked cylinder head or block, and/or other internal engine damage.

a. Thermostat Removal

1. Park the machine on a firm, level surface, level the machine, fully retract the boom, lower the boom, place the travel select lever in the (N) NEUTRAL position, engage the parking brake, and shut the engine OFF.
2. Place a Do Not Operate Tag on both the ignition key switch and steering wheel, stating that the machine should not be operated.
3. Open the engine cover. Allow the system fluids to cool.
4. Properly disconnect the battery.
5. Slowly turn the radiator cap to the first stop and allow any pressure to escape. Remove the radiator cap.
6. Place a funnel at the base of the radiator to channel the drained coolant into the container. Loosen the drain plug and slowly remove to allow the coolant to drain. Transfer the coolant into a properly labeled container. Dispose of properly if coolant needs to be replaced. Replace the radiator drain plug.
7. Disconnect the Engine Water Temperature Sender.

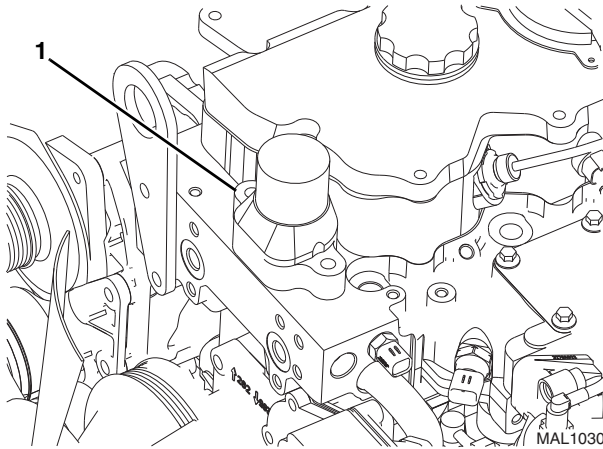

8. Remove the capscrews securing the thermostat housing (1) to the engine.
9. Remove the thermostat housing, old gasket and thermostat. Clean all gasket surfaces. **DO NOT** let any debris into the thermostat opening.

Note: ALWAYS use the correct thermostat and install a new gasket. **NEVER** operate the engine without a thermostat, or engine damage will result.

b. Thermostat Installation

1. Install the engine thermostat, thermostat gasket and thermostat housing. Secure with the two capscrews.
2. Connect the Engine Water Temperature sender.
3. Properly connect the battery.
4. Open the radiator cap, and fill the radiator completely with a 50/50 mixture of ethylene glycol and water. Add the coolant solution at a maximum rate of 1.3 gallons per minute (5 liters per minute). Replace and tighten the radiator cap. Add coolant to the overflow bottle until the bottle is 1/4 to 1/2 full. This overfilling will compensate for any air trapped in the cooling system.
5. Run the engine to operating temperature. Visually check for leaks with the engine running. Check the coolant level in the overflow bottle and fill, or drain, as necessary.
6. Close and secure the engine cover.
7. Remove the Do Not Operate Tags from both the ignition key switch and the steering wheel.

7.4.3 Radiator/Oil Cooler and Replacement

Before considering radiator or oil cooler replacement for other than obvious damage, conduct a cooling system pressure test check the coolant specific gravity, coolant level, fan belt tension and dash panel temperature indicator.

- If the engine runs hot, check the temperature of the upper radiator hose.
- If the hose is not hot, the thermostat may be stuck in the closed position.
- If the engine has overheated, performance may suffer, indicating other damage including a leaking cylinder head gasket, cracked cylinder head or block, and/or other internal engine damage.

TL642 - BEFORE S/N TBK01167 EXCLUDING TBK01162
TL943 - BEFORE S/N TBL01599 EXCLUDING TBL01551 & TBL01585

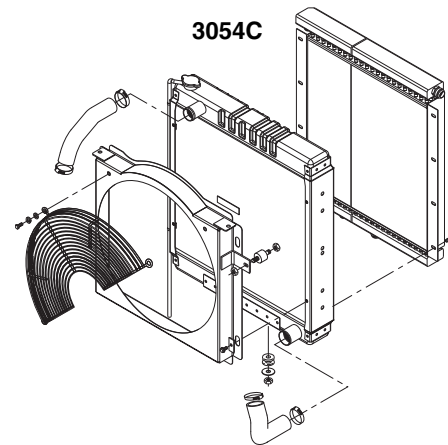

TL642 - S/N TBK01167 & AFTER INCLUDING TBK01162
TL943 - S/N TBL01599 & AFTER INCLUDING TBL01551 & TBL01585

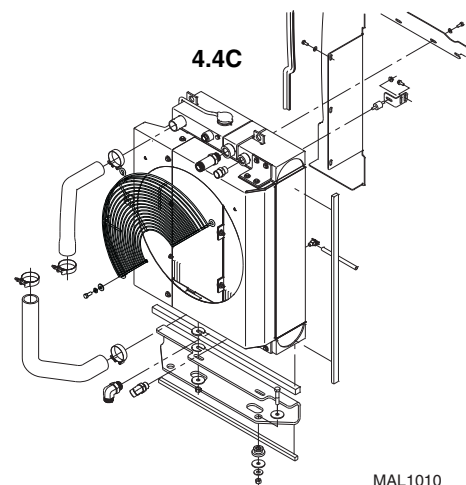

MAL1010



Engine

a. Radiator/Oil Cooler Removal

1. Park the machine on a firm, level surface, level the machine, fully retract the boom, lower the boom, place the travel select lever in the (N) NEUTRAL position, engage the parking brake, and shut the engine OFF.
2. Place a Do Not Operate Tag on both the ignition key switch and steering wheel, stating that the machine should not be operated.
3. Open the engine cover. Allow the system fluids to cool.
4. Properly disconnect the battery.
5. Slowly turn the radiator cap to the first stop and allow any pressure to escape. Remove the radiator cap.
6. Place a suitable container beneath the radiator drain.
7. Place a funnel at the base of the radiator to channel the drained coolant into a container. Loosen the drain cock and slowly remove to allow the coolant to drain. Transfer the coolant into a properly labeled container. Dispose of properly if coolant needs to be replaced. Tighten the radiator drain cock.
8. Loosen the radiator clamp on the top radiator hose. Work the hose off the radiator. Position the hose out of the way to allow radiator removal, or remove the hose from the engine. Inspect the hose, and replace if necessary.
9. Loosen the clamp on the radiator return (lower) hose. Work the hose off the radiator. Position the hose out of the way to allow radiator removal, or remove the hose from the engine. Inspect the hose, and replace if necessary.
10. Label, disconnect and cap the hoses on the oil cooler.
11. Remove the radiator fan shroud.
12. Remove the radiator bracket.
13. Remove the nuts and washers from the radiator mounts.
14. Carefully lift the radiator/oil cooler out of the engine compartment.

Note: *If more clearance is needed to remove the radiator, the engine fan may be removed for easier access.*

b. Radiator/Oil Cooler Installation

1. Install the isolator mounts to the bottom of the radiator. Place the radiator in the engine compartment at its original orientation. Secure the radiator with the previously used hardware.
 2. Install the radiator bracket.
- Note:** *Be sure there is adequate clearance between the radiator and the engine fan.*
3. If necessary, install the engine fan.
 4. Install the radiator fan shroud.
 5. Uncap and connect transmission inlet and outlet hoses to the radiator.
 6. At the lower radiator return hose, and with the clamp installed over the hose, work the hose onto the radiator, and tighten the clamp.
 7. At the upper radiator hose, and with the clamp installed over the hose, work the hose onto the radiator, and tighten the clamp.
 8. Open the radiator cap and fill the radiator completely with a 50/50 mixture of ethylene glycol and water. Add the coolant solution at a maximum rate of 1.3 gallons per minute (5 liters per minute). Replace and tighten the radiator cap. Refer to Section 2.4, "Fluids and Lubricant Capacities," for proper capacities.
 9. Properly connect the battery.
 10. Run the engine to operating temperature. Visually check for leaks with the engine running. Check the coolant level in the overflow bottle and fill, or drain, as necessary.
 11. Close and secure the engine cover.
 12. Remove the Do Not Operate Tags from both the ignition key switch and the steering wheel.

7.5 ENGINE ELECTRICAL SYSTEM

The engine electrical system, including the starter, alternator and primary wiring, is described in Section 9.5, "Electrical System Schematics."



7.6 FUEL SYSTEM

7.6.1 Diesel Fuel

Fuel represents a major portion of machine operating costs and therefore must be used efficiently. ALWAYS use a premium brand of high-quality, clean diesel fuel. Low cost, inferior fuel can lead to poor performance and expensive engine repair.

Note: Use only diesel fuel designed for diesel engines. Some heating fuels contain harmful chemicals that can seriously affect engine efficiency and performance.

Note: Due to the precise tolerances of diesel injection systems, keep the fuel clean, and free of dirt and water. Dirt and water in the fuel system can cause severe damage to both the injection pump and the injection nozzles. Use ASTM #2 diesel fuel with a minimum Cetane rating of 40. #2 diesel fuel gives the best economy and performance under most operating conditions. Fuels with Cetane numbers higher than 40 may be needed in high altitudes or extremely low ambient temperatures to help prevent misfiring and excessive smoking.

Inform the owner/operator of the machine to use #2 diesel fuel, unless ambient temperatures are below 32° F (0° C). When temperatures are below 32° F (0° C), a blend of #1 diesel and #2 diesel fuels (known as “winterized” #2 diesel) may be used.

Note: #1 diesel fuel may be used, however, fuel economy will be reduced.

Use a low-sulfur content fuel with a cloud point (the temperature at which wax crystals form in diesel fuel) at least 10° below the lowest expected fuel temperature. The viscosity of the fuel must be kept above 1.3 centistrokes to provide adequate fuel system lubrication.

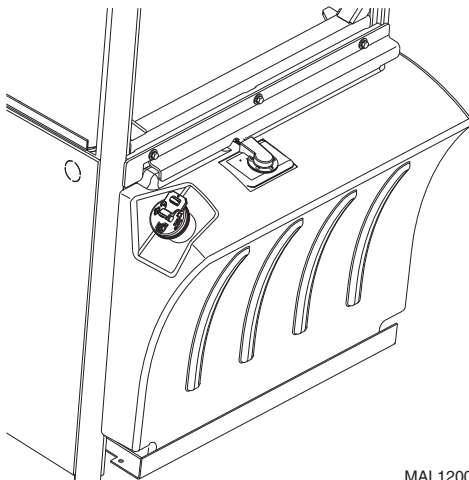

MAL1200

7.6.2 Fuel Tank

Note: The fuel tank is a one piece unit. It is located on the rear of the cab. If it is determined that the fuel tank must be removed, the fuel must be drained before tank removal. Always dispose of fuel properly.

a. Fuel Tank Removal

1. Park the machine on a firm, level surface, level the machine, fully retract the boom, lower the boom, place the travel select lever in the (N) NEUTRAL position, engage the parking brake, and shut the engine OFF.
2. Place a Do Not Operate Tag on both the ignition key switch and steering wheel, stating that the machine should not be operated.
3. Open the engine cover. Allow the system fluids to cool.
4. Properly disconnect the battery.

Note: If replacing the tank, remove all internal and external components from the old tank, and retain for use on the replacement tank.

Note: Have a dry chemical (Class B) fire extinguisher near the work area.

5. Remove fuel tank drain plug, and drain fuel into an approved and suitable container. Dispose of fuel properly.
6. Label, disconnect and cap the fuel lines from the bottom of the fuel tank.
7. Disconnect the fuel gauge harness.
8. Remove screws securing fuel sender to the tank. Remove fuel sender from tank.
9. Remove the bolts on the fuel tank hold down bar.
10. Lift the empty fuel tank from the rear of the cab.

b. Disassembly

The fuel tank is a one-piece unit and cannot be disassembled. The fuel level indicator can be removed and reused on the new replacement tank. Dispose of the old tank according to local regulations concerning hazardous materials disposal.

c. Cleaning and Drying

If contaminated fuel or foreign material is in the tank, the tank can usually be cleaned.

Note: If a leak is suspected in the fuel tank, contact your local Service Department.

To clean the fuel tank:



Engine

1. Have a dry chemical (Class B) fire extinguisher near the work area.
2. Remove the fuel or oil tank drain plug, and safely drain any fuel into a suitable container. Dispose of fuel properly.
3. Clean the fuel tank with a high-pressure washer, or flush the tank with hot water for five minutes and drain the water. Dispose of contaminated water properly.
4. Add a diesel fuel emulsifying agent to the tank. Refer to the manufacturer's instructions for the correct emulsifying agent-to-water mixture ratio. Refill the tank with water, and agitate the mixture for 10 minutes. Drain the tank completely. Dispose of contaminated water properly.
5. Refill the fuel tank with water until it overflows. Completely flush the tank with water. Empty the fuel tank, and allow it to dry completely.

d. Assembly

The fuel level indicator can be removed and reused on the new replacement tank. Dispose of the old tank according to local regulations concerning hazardous materials disposal regulations.

e. Inspection

Note: If a leak is suspected in the fuel tank, contact your local Service Department.

1. Inspect the fuel tank thoroughly for any cracks, slices, leaks or other damage.
2. With the fuel tank removed from the machine, plug all openings except one elbow fitting. Install the elbow fitting, and apply approximately 1-1.5 psi (7-10 kPa) of air pressure through the elbow. Check the reservoir for leaks by applying a soap solution to the exterior and look for bubbles to appear at the cracked or damaged area.

f. Fuel Tank Installation

1. Set fuel tank in its original orientation at the rear of the cab.
2. Install the fuel tank hold down bar.
3. Install the fuel sender with new gasket into the fuel tank and secure with screws. **DO NOT** overtighten.
4. Connect the previously labeled fuel hoses to their appropriate locations. Secure with clamps.
5. Connect the fuel gauge harness.
6. Fill the fuel tank according to specifications. Refer to Section 2.4, "Fluids and Lubricant Capacities."

7. Check fuel tank for leaks.
8. Properly connect the battery.
9. Close and secure the engine cover.
10. Remove the Do Not Operate Tags from both the ignition key switch and the steering wheel.

7.6.3 After Fuel System Service

1. Drain and flush the fuel tank if it was contaminated.
2. Vent air from the fuel system in accordance with the instructions found in the appropriate Operation & Maintenance Manual.
3. Fill the fuel tank with fresh, clean diesel fuel as required.

7.7 ENGINE EXHAUST SYSTEM

7.7.1 Exhaust System Removal

1. Park the machine on a firm, level surface, level the machine, fully retract the boom, lower the boom, place the travel select lever in the (N) NEUTRAL position, engage the parking brake, and shut the engine OFF.
2. Place a Do Not Operate Tag on both the ignition key switch and steering wheel, stating that the machine should not be operated.
3. Open the engine cover. Allow the system fluids to cool.
4. Properly disconnect the battery.

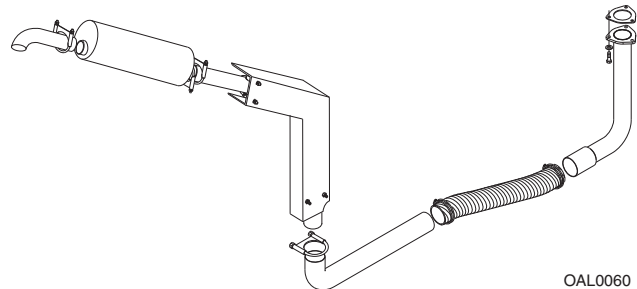

5. Remove the heat shield attached to the engine.
6. Loosen and remove the nuts from the exhaust pipe at the exhaust manifold.
7. Disconnect and remove the clamp attaching the exhaust pipe to the frame.
8. Disconnect and remove the clamp connecting the muffler and the exhaust pipe.
9. Disconnect and remove the clamp connecting the tail pipe to the muffler and remove the tail pipe.



10. Loosen and remove the bolts at the front and rear of the muffler, remove the muffler.
11. Remove the exhaust heat shield (if equipped).

7.7.2 Exhaust System Installation

Note: Keep all clamps loosened until entire exhaust system is in place.

1. Install the exhaust pipe with a new seal to the exhaust manifold.
- Note:** Replace the nuts and the exhaust manifold studs if damaged.
2. Install the exhaust pipe clamp.
 3. Install the muffler to the exhaust pipe and bolt the muffler to the frame.
 4. Install the clamp securing the muffler to the exhaust pipe.
 5. Install the clamp securing the muffler to the tail pipe.
 6. Install the exhaust heat shield (if equipped).
 7. Adjust the muffler, exhaust and tail pipes for proper clearance then tighten all clamps.
 8. Install the heat shield attached to the engine.
 9. Properly connect the battery.
 10. Start engine and check for exhaust leaks at all exhaust connections. Adjust or repair as needed.
 11. Close and secure the engine cover.
 12. Remove the Do Not Operate Tags from both the ignition key switch and the steering wheel.

7.8 AIR CLEANER ASSEMBLY

CAUTION

NEVER run the engine with only the inner safety element installed.

Note: Refer to the appropriate Operation & Maintenance Manual for your machine for the correct element change procedure.

TL642 - Before S/N TBK01167 excluding TBK01162

TL943 - Before S/N TBL01599 excluding TBL01551 & TBL01585

7.8.1 Air Cleaner Assembly Removal

1. Park the machine on a firm, level surface, level the machine, fully retract the boom, lower the boom, place the travel select lever in the (N) NEUTRAL position, engage the parking brake, and shut the engine OFF.
2. Place a Do Not Operate Tag on both the ignition key switch and steering wheel, stating that the machine should not be operated.
3. Open the engine cover. Allow the system fluids to cool.
4. Properly disconnect the battery.

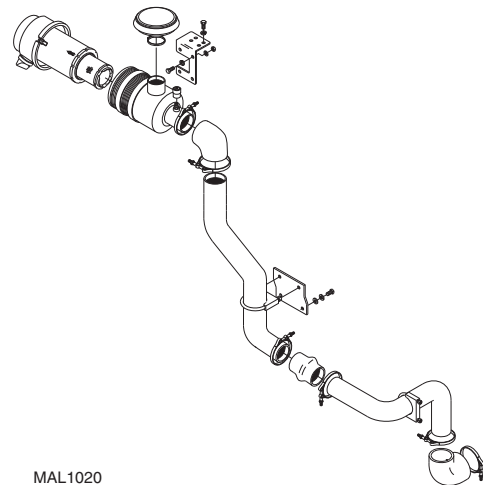

MAL1020

5. Remove the clamp securing the air intake elbow to the air cleaner assembly. Lift the air intake elbow off the air cleaner.
6. Remove the capscrews and nuts securing the air cleaner mounting bracket to the air cleaner mounting plate. Remove the air cleaner assembly.

7.8.2 Air Cleaner Assembly Installation

Note: Apply Loctite® 242™ to the capscrew threads before installation.

1. With the air cleaner assembly attached, install the air cleaner mounting bracket using capscrews and nuts.
2. Place the loosened clamps over the air outlet elbow and install elbow on the air cleaner assembly.
3. Adjust and tighten both clamps before starting the machine.
4. Properly connect the battery.
5. Close and secure the engine cover.
6. Remove the Do Not Operate Tags from both the ignition key switch and the steering wheel.



Engine

TL642 - Before S/N TBK01167 excluding TBK01162

TL943 - Before S/N TBL01599 excluding TBL01551 & TBL01585

7.8.3 Air Cleaner Assembly Removal

1. Park the machine on a firm, level surface, level the machine, fully retract the boom, lower the boom, place the travel select lever in the (N) NEUTRAL position, engage the parking brake, and shut the engine OFF.
2. Place a Do Not Operate Tag on both the ignition key switch and steering wheel, stating that the machine should not be operated.
3. Open the engine cover. Allow the system fluids to cool.
4. Properly disconnect the battery.

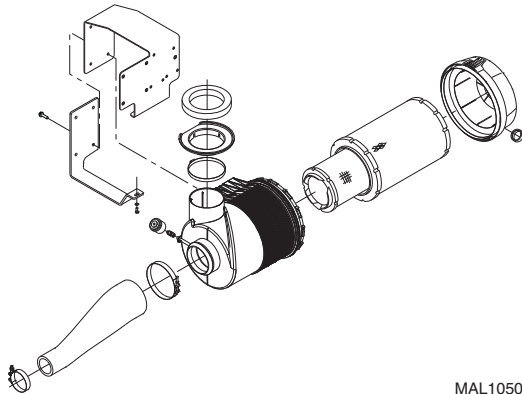

5. Remove the clamp securing the air intake elbow to the air cleaner assembly. Lift the air intake elbow off the air cleaner.
6. Remove the capscrews and nuts securing the air cleaner mounting bracket to the air cleaner mounting plate. Remove the air cleaner assembly.

7.8.4 Air Cleaner Assembly Installation

Note: Apply Loctite® 242™ to the capscrew threads before installation.

1. With the air cleaner assembly attached, install the air cleaner mounting bracket using capscrews and nuts.
2. Place the loosened clamps over the air outlet elbow and install elbow on the air cleaner assembly.
3. Adjust and tighten both clamps before starting the machine.
4. Properly connect the battery.
5. Close and secure the engine cover.

6. Remove the Do Not Operate Tags from both the ignition key switch and the steering wheel.

7.9 ENGINE REPLACEMENT

7.9.1 Engine Removal

Note: The radiator and oil cooler must be removed from the machine before engine removal. Refer to Section 7.4, "Engine Cooling System." Several additional components must be removed before engine removal. They will be addressed in the following procedures.

1. Park the machine on a firm, level surface, level the machine, fully retract the boom, lower the boom, place the travel select lever in the (N) NEUTRAL position, engage the parking brake, and shut the engine OFF.
2. Place a Do Not Operate Tag on both the ignition key switch and steering wheel, stating that the machine should not be operated.
3. Open the engine cover. Allow the system fluids to cool.
4. Disconnect the positive (+) and negative (-) battery cables and remove the battery.
5. Remove the engine cover. Mark the position of the cover to help with cover adjustment when being reinstalled.
6. Remove the oil pan cover underneath the engine compartment.
7. Drain and remove the radiator assembly. Refer to Section 7.4.3, "Radiator/Oil Cooler and Replacement."
8. Remove the heater hoses attached to the engine (if equipped).

Note: The engine harness is routed and attached to the engine using hold-down clamps and plastic wire ties at various places on the engine. Before removing engine, ensure that the harness has been completely separated (disconnected) from the engine. Move the harness clear of the engine, and with the help of an observer, ensure that the engine clears the harness during removal.

9. Label and disconnect all wire harness connections on the engine.
10. Disconnect and cap the fuel inlet line at the fuel filter head.
11. Disconnect and cap the fuel return line from the fuel filter head.

Note: Steps 12 & 13 apply to the CAT 3054C ONLY.



12. Mark the location of the throttle cable at the throttle cable mount. Loosen jam nuts and remove.

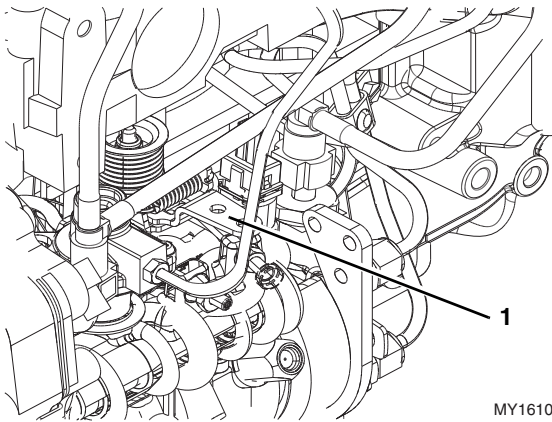

MY1610

13. Disconnect the throttle cable at the engine throttle lever (1).
14. Remove the exhaust pipe from the exhaust manifold. Refer to Section 7.7.1, "Exhaust System Removal."
15. Loosen the clamps on the sleeve reducer at the engine and on the air suction pipe.
16. Remove the air cleaner assembly. Refer to Section 7.8.1, "Air Cleaner Assembly Removal."
17. Remove the access plug from side of the engine bell housing. This will allow access to remove the eight bolts holding the flex plate to the engine flywheel.
18. Turn the engine over slowly by hand and align each of the eight flex plate bolts to be accessed. Remove them one at a time.

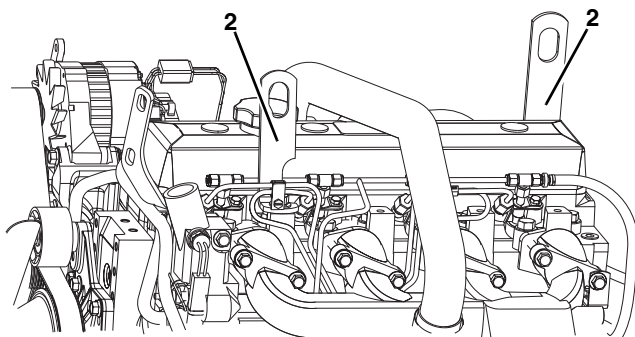

MY1590

19. Secure the engine with a lifting strap or chain from the appropriate lifting points (2). Use a suitable hoist or overhead crane with a minimum lifting capacity of 1000 lb (453 kg).
20. Remove the bolts and washer securing the engine mounts.

21. Place a support or jack under the transmission to hold the transmission in place while engine is being removed.
22. Remove the ten bolts holding the transmission to the engine. Slightly lift and pull the engine out of the machine. Have an assistant ensure that the engine clears all frame components during removal.
23. Place engine on a flat, level surface.

7.9.2 Engine Installation

1. Use a suitable hoist or overhead crane with a minimum lifting capacity of 1000 lb (453 kg). Attach a lifting chain to the front and rear engine lift brackets (2), and lift engine clear of the ground.

Note: Apply Loctite® 242™ to the engine mount bracket capscrew threads before installation.

2. Install two guide studs in the bell housing holes.
3. Lift the engine and slowly push and lower into the engine bay. Have an assistant ensure that the engine clears the frame, hose and harness components during engine installation. Position engine brackets over the front frame mounts.
4. Push the engine towards the transmission aligning the guide studs and the torque convertor shaft with the corresponding holes.
5. Push the engine against the transmission and install eight of the ten bolts and washers. Remove both guide studs and replace with the remaining two bolts and washers. Torque to 53-58 lb-ft (72-78 Nm).
6. Remove the support from under the transmission and lower the engine the remainder of the way onto the frame. Align the motor mount holes and install the bolts. Apply Loctite® 242™ to the motor mount bolts and torque to 220 lb-ft (298 Nm).
7. Turn the engine over slowly by hand and align each of the eight flex plate bolts through the access plug in the bell housing. Install them one at a time. DO NOT fully tighten until all of the capscrews and locknuts are in place. Torque to 26-29 lb-ft (35-39 Nm). Replace access plug.
8. Install the exhaust pipe. Refer to Section 7.7.2, "Exhaust System Installation."
9. Install the complete air cleaner assembly. Refer to Section 7.8.2, "Air Cleaner Assembly Installation."
- Note:** Steps 10 & 11 apply to the CAT 3054C ONLY.
10. Install and tighten the jam nuts on the throttle cable at the throttle cable mount.



Engine

11. Connect the throttle cable at the engine throttle lever.
12. Connect the fuel inlet line to the fuel filter head.
13. Connect the fuel return line to the fuel filter head.
14. Connect all the labeled wire harness connections on the engine.
15. Install both heater hoses to the engine and tighten clamps (if equipped).
16. Install the complete radiator assembly. Refer to Section 7.4.3, "Radiator/Oil Cooler and Replacement."
17. Install the engine cover and adjust.
18. Install the battery and connect the positive (+) and negative (-) cables.
19. Check that all hydraulic system, electrical system, cooling system, fuel system and exhaust system connections are correct and connected tightly.
20. From within the cab, lightly depress the throttle pedal to full-throttle position. As needed, adjust the limit-stop screw until it touches the pedal bracket.

Note: *Have an assistant stand by with a Class B fire extinguisher.*

21. Start the engine and run to normal operating temperature then shut off the engine. While the engine is cooling, check for leaks.
22. Allow the engine to cool. Check the radiator coolant level, and top off with a 50/50 mixture of ethylene glycol and water. Add the coolant solution at a maximum rate of 1.3 gallons per minute (5 liters per minute). Replace the radiator cap.
23. Check for leaks from the engine, main hydraulic pump and lines, transmission, hydraulic reservoir and fuel tank. Check the levels of all fluids and lubricants. Fill as required.

Note: *During the full throttle check:*

- **DO NOT** operate any hydraulic function.
 - **DO NOT** steer or apply any pressure to the steering wheel.
 - Keep the transmission in (N) NEUTRAL.
24. Obtain and connect an appropriate engine analyzer or tachometer. Check the engine rpm at full throttle. If the rpm is not 2675-2750, readjust the throttle limit-stop screw at the throttle pedal within the cab.
 25. Purge the hydraulic system of air by operating all boom functions through their entire range of motion several times. Check the hydraulic oil level.

26. Check for proper operation of all components.
27. Turn the engine OFF.
28. Install the oil pan cover underneath the engine compartment.
29. Close and secure the engine cover.
30. Remove the Do Not Operate Tags from both the ignition key switch and the steering wheel.



7.10 ENGINE DRIVE PLATE

7.10.1 Drive Plate Removal

1. Park the machine on a firm, level surface, level the machine, fully retract the boom, lower the boom, place the travel select lever in the (N) NEUTRAL position, engage the parking brake and shut the engine OFF.

Note: In order to remove the engine drive plates, the engine and transmission must be separated.

2. Refer to Section 6.4.1, "Transmission Removal," or Section 7.9.1, "Engine Removal."

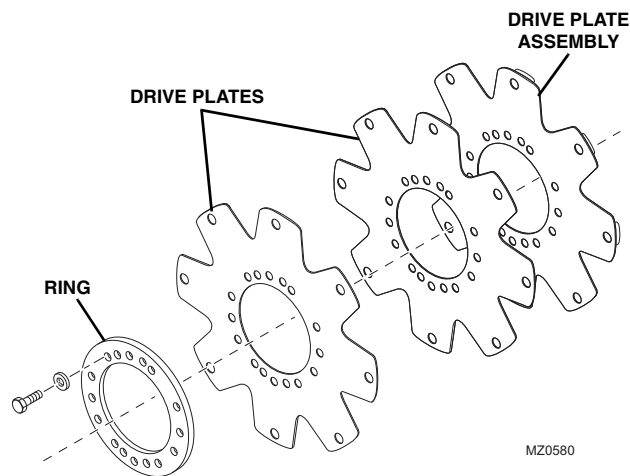

3. Remove the eight bolts holding the drive plates to the flywheel.
4. With the drive plates and torque converter removed, loosen and remove the six bolts and six lock washers holding the three drive plates to the torque converter.
5. Replace all three drive plates if damaged.

7.10.2 Drive Plate Installation

1. Install the three new drive plates on the torque converter and torque the six bolts with lock washers to 26-29 lb-ft (35-39 Nm).
2. Mount the drive plate / converter assembly to the transmission.
3. Refer to Section 6.4.3, "Transmission Installation," or Section 7.9.2, "Engine Installation," for the remainder of the installation.



Engine

7.11 TROUBLESHOOTING

Trouble	Possible Causes (see key, below)
Low Cranking Power	1, 2, 3, 4
Will Not Start	5, 6, 7, 8, 9, 10, 12, 13, 14, 15, 16, 17, 18, 19, 20, 22, 31, 32, 33
Difficult Starting	5, 7, 8, 9, 10, 11, 12, 13, 14, 15, 16, 18, 19, 20, 21, 22, 24, 29, 31, 32, 33, 61, 63
Lack of Power	8, 9, 10, 11, 12, 13, 14, 18, 19, 20, 21, 22, 23, 24, 25, 26, 27, 31, 32, 33, 61, 63
Misfiring	8, 9, 10, 12, 13, 14, 16, 18, 19, 20, 25, 26, 28, 29, 30, 32
Excessive Fuel Consumption	11, 13, 14, 16, 18, 19, 20, 22, 23, 24, 25, 27, 28, 29, 31, 32, 33, 63
Black Exhaust	11, 13, 14, 16, 18, 19, 20, 22, 24, 25, 27, 28, 29, 31, 32, 33, 61, 63
Blue/White Exhaust	4, 16, 18, 19, 20, 25, 27, 31, 33, 34, 35, 45, 56, 62
Low Oil Pressure	4, 36, 37, 38, 39, 40, 42, 43, 44, 58
Knocking	9, 14, 16, 18, 19, 22, 26, 28, 29, 31, 33, 35, 36, 45, 46, 59
Erratic Running	7, 8, 9, 10, 11, 12, 13, 14, 16, 20, 21, 23, 26, 28, 29, 30, 33, 35, 45, 59
Vibration	13, 14, 20, 23, 25, 26, 29, 30, 33, 45, 47, 48, 49
High Oil Pressure	4, 38, 41
Overheating	11, 13, 14, 16, 18, 19, 24, 25, 45, 50, 51, 52, 53, 54, 57
Excessive Crankcase Pressure	25, 31, 33, 34, 45, 55, 60
Poor Compression	11, 19, 25, 28, 29, 31, 32, 33, 34, 46, 59
Starts and Stops	10, 11, 12

Key to Possible Causes



Trouble	Possible Causes (see key, below)	
<ol style="list-style-type: none"> 1. Battery charge low 2. Bad electrical connection 3. Faulty starter motor 4. Incorrect grade of lubricating oil 5. Low cranking speed 6. Fuel tank empty 7. Faulty stop control operation 8. Fuel inlet restricted 9. Faulty fuel lift pump 10. Clogged fuel filter 11. Restricted air cleaner 12. Air in fuel system 13. Faulty fuel injection pump 14. Faulty fuel injectors or incorrect type 15. Incorrect use of cold start equipment 16. Faulty cold start equipment 17. Broken fuel injection pump drive 18. Incorrect fuel pump timing 19. Incorrect valve timing 20. Poor compression 	<ol style="list-style-type: none"> 21. Blocked fuel tank vent 22. Incorrect grade of fuel 23. Sticking throttle or restricted movement 24. Exhaust pipe restriction 25. Leaking cylinder head gasket 26. Overheating 27. Cold running 28. Incorrect tappet adjustment 29. Sticking valves 30. Incorrect high pressure pipes 31. Worn cylinder bores 32. Pitted valves and seats 33. Broken, worn or sticking piston ring(s) 34. Worn valve stems and guides 35. Restricted air cleaner 36. Worn or damaged bearings 37. Insufficient oil in sump 38. Inaccurate gauge 39. Oil pump worn 40. Pressure relief valve sticking open 41. Pressure relief valve sticking closed 42. Broken relief valve spring 	<ol style="list-style-type: none"> 43. Faulty suction pipe 44. Restricted oil filter 45. Piston seizure/pick up 46. Incorrect piston height 47. Damaged fan 48. Faulty engine mounting 49. Incorrectly aligned flywheel housing or incorrectly aligned flywheel 50. Faulty thermostat 51. Restriction in water jacket 52. Loose fan belt 53. Restricted radiator 54. Faulty water pump 55. Restricted breather pipe 56. Damaged valve stem oil deflectors (if fitted) 57. Coolant level too low 58. Blocked sump strainer 59. Broken valve spring 60. Exhauster or vacuum pipe leak 61. Turbo impeller damaged or dirty 62. Turbo lubricating oil seal leak 63. Induction system leaks



Section 8 Hydraulic System

Contents

PARAGRAPH	TITLE	PAGE
8.1	Hydraulic Component Terminology	8-2
8.2	Safety Information	8-3
8.3	Hydraulic Pressure Diagnosis	8-3
8.3.1	Pressure Checks and Adjustments	8-3
8.4	Hydraulic Circuits	8-4
8.4.1	Hydraulic Pressures	8-4
8.4.2	Tilt Circuit Port Relief Adjustment	8-4
8.4.3	Hydraulic Schematic - TL642	8-9
8.4.4	Hydraulic Schematic - TL943 Before S/N TBL01599 excluding TBL01551 & TBL01585	8-11
8.4.5	Hydraulic Schematic - TL943 S/N TBL01599 & After including TBL01551 & TBL01585	8-13
8.5	Hydraulic Reservoir	8-14
8.5.1	Hydraulic Oil Reservoir Draining	8-14
8.5.2	Hydraulic Oil Reservoir Filling	8-14
8.5.3	Hydraulic Oil Reservoir Removal/Installation	8-14
8.6	Engine Implement Pump	8-15
8.6.1	Pump Replacement	8-15
8.7	Control Valves	8-18
8.7.1	Main Control Valve	8-18
8.7.2	Service Brake Valve	8-20
8.7.3	Brake Test	8-21
8.7.4	Steering Orbitrol Valve	8-21
8.7.5	Steer Select Valve	8-22
8.7.6	Outrigger Valve (if equipped)	8-23
8.8	Hydraulic Cylinders	8-24
8.8.1	General Cylinder Removal Instructions	8-24
8.8.2	Cylinder Pressure Checking	8-26
8.8.3	Steering Cylinders	8-26
8.8.4	Cylinder Torque Specifications - TL642	8-27
8.8.5	Cylinder Torque Specifications - TL943	8-28



8.1 HYDRAULIC COMPONENT TERMINOLOGY

To understand the safety, operation and service information presented in this section, it is necessary that the operator/mechanic be familiar with the name and location of the hydraulic components of the machine. The following illustration identifies the components that are referred to throughout this section.

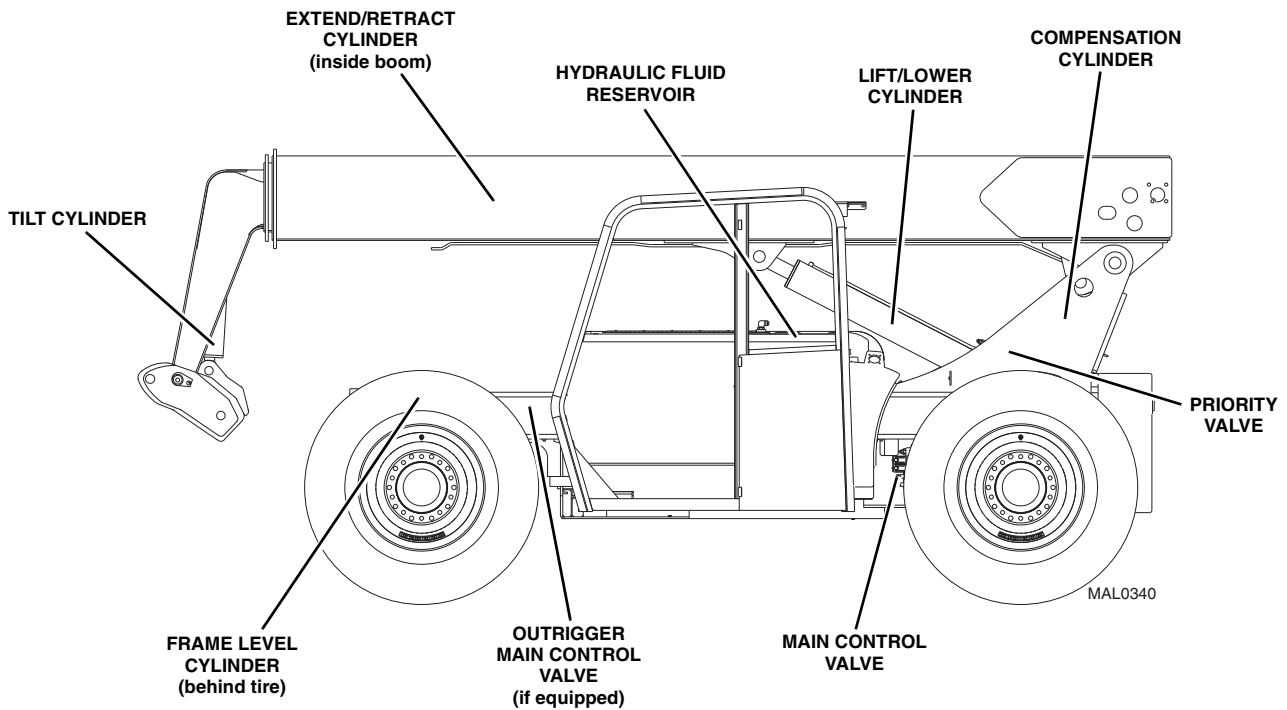



8.2 SAFETY INFORMATION

WARNING

DO NOT service the machine without following all safety precautions as outlined in Section 1, "Safety Practices," of this manual.

Petroleum-based hydraulic fluids are used in this machine. The temperature of hydraulic fluid increases during the operation of various hydraulic functions. A heated petroleum-based hydraulic fluid presents a fire hazard, especially when an ignition source is present. Hydraulic fluid has a flash point that ranges from 300-600° F (150-318° C) and an auto-ignition temperature of 500-750° F (262-402° C).

Accordingly, periodically inspect all hydraulic system components, hoses, tubes, lines, fittings, etc. Carefully examine any deterioration and determine whether any further use of the component would constitute a hazard. If in doubt, replace the component.

Operate the hydraulic controls after the engine has stopped to relieve trapped pressure.

Note: *Residual pressure may remain in hydraulic cylinders, hoses, valve bodies, components, etc. If the hydraulic lines going to or coming from a component are taut, slowly and cautiously relieve ("bleed off") pressure.*

Whenever you disconnect a hydraulic line, coupler, fitting or other component, slowly and cautiously loosen the part involved. A hissing sound or slow seepage of hydraulic fluid may occur in most cases. After the hissing sound has ceased, continue removing the part. Any escaping oil should be directed into an appropriate container. Cap or otherwise block off the part to prevent further fluid seepage.

Hydraulic system maintenance will, at times, require that the engine be operated. Always follow safety precautions.

A major cause of hydraulic component failure is contamination. Keeping the hydraulic fluid as clean as possible will help avoid downtime and repairs. Sand, grit and other contaminants can damage the finely machined surfaces within hydraulic components. If operating in an exceptionally dirty environment, change filters and inspect the fluid more often. When servicing the system, cap or plug hydraulic fittings, hoses and tube assemblies. Plug all cylinder ports, valves and the hydraulic reservoir, and pump openings until installation occurs. Protect threads from contamination and damage.

Some hydraulic functions are actuated by interfacing with electrical system components (switches, solenoids and sensors). When the hydraulic system is not functioning properly, check the electrical aspect of the malfunctioning circuit also. Refer to Section 9.6, "Circuit Breakdowns," in this manual.

8.3 HYDRAULIC PRESSURE DIAGNOSIS

8.3.1 Pressure Checks and Adjustments

When diagnosing trouble in the hydraulic system, use the hydraulic testing information in Section 8.4.1, "Hydraulic Pressures."

In general, follow the steps below whenever conducting pressure checks and performing adjustments:

1. Park the machine on a firm, level surface. Engage the park brake, place the travel select lever in (N) NEUTRAL, level the boom and turn the engine OFF.
2. The test port is located at the top right corner of the main control valve. Install a pressure gauge capable of measuring at least 10% more pressure than that which the circuit being checked operates under.
3. Start the engine. Operate machine functions several times to allow hydraulic oil to reach operating temperature. The hydraulic oil temperature should be between 100-120°F (38-49° C). If a temperature gauge or thermometer is unavailable, the hydraulic oil reservoir should be warm to the touch.
4. Refer to Section 8.4.1, "Hydraulic Pressures," for testing procedures.
5. Fully depress the accelerator pedal if required. Place and hold the joystick in the position needed to operate the particular machine function being checked. Continue holding the joystick in position until pressure readings are taken.
6. Check the pressure gauge reading. It should read as specified in the Pressure Readings column of the charts found in Section 8.4.1, "Hydraulic Pressures." If the reading is not as specified, turn the engine OFF and check other components in the system. Verify that all related hydraulic components and electrical switches, sensors, solenoids, etc. are operating correctly.
7. Adjust the relief valve by turning the adjustment screw. Turning clockwise will increase the pressure; turning the screw counterclockwise will decrease the pressure.



Hydraulic System

8. Start the engine and check the pressure again. Turn the engine OFF. If there is pressure reading in the gauge, bleed it off then disconnect or remove the pressure gauge from the machine.

8.4 HYDRAULIC CIRCUITS

This section covers the hydraulic circuits and includes listings for all hydraulic function pressures, where and how to check those pressures and a hydraulic schematic.

Electrical and hydraulic functions are often related. Verify that the electrical components of the circuit are functioning properly whenever troubleshooting the hydraulic circuit.

Always check the following before beginning to troubleshoot a circuit that is not functioning correctly.

1. Check the hydraulic oil level in the reservoir. Oil level should be to the middle of the sight glass with all cylinders retracted.
2. Check hoses, tubes, fittings and other hydraulic components for leaks, bends, kinks, interference, etc.
3. Check for air in the hydraulic system. Erratic machine performance and/or spongy cylinder operation are signs of air in the hydraulic system.

If air in the hydraulic system is suspected, you will hear air leakage when hydraulic fittings are loosened and see air bubbles in the hydraulic fluid.

Loose fittings, faulty o-rings or seals, trapped oil, leaks, system opened for service, etc., can cause air in the system. Determine what is causing air to enter the system and correct it. Bleed air from the system.

8.4.1 Hydraulic Pressures

a. Checking Pressures

1. Start the machine and warm the hydraulic system to operating temperature.
2. Shut off the machine and install a digital or a 5000 psi (345 bar) gauge to the appropriate test port on the priority valve.
3. Start the machine, run the engine and follow the procedures in Section 8.4.2, c. "Pressure Specifications - TL642," Section d, "Pressure Specifications - TL943 Before S/N TBL01599 excluding TBL01551 & TBL01585," or Section e, "Pressure Specifications - TL943 S/N TBL01599 & After including TBL01551 & TBL01585."

b. Adjusting Hydraulic Pressure

1. Shut the machine off. Remove the cap on the relief (if necessary).
2. Start the machine and loosen the jam nut on the relief. Turn the relief clockwise to increase pressure or counter-clockwise to decrease pressure. Set to the correct pressure.
3. Tighten the jam nut and recheck the pressure at full throttle. If the reading is within specification, shut the machine off, install the safety cap and remove the gauge from the test port.
4. If the proper pressure cannot be set, use the accompanying hydraulic schematic and/or the electrical schematic to help troubleshoot and correct the problem.

8.4.2 Tilt Circuit Port Relief Adjustment

The following procedure is specific to the tilt circuit only and should be performed and verified if the main and/or load sense circuits pressures are in question.

1. Remove any attachment from the quick coupler assembly. Refer to Section 3.9, "Quick Coupler Assembly."
2. Raise the boom for access to the compensation cylinder.

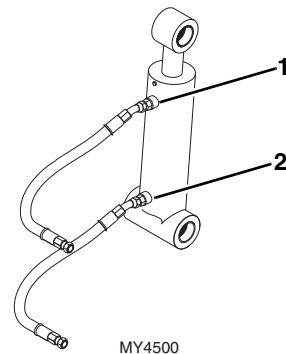

3. Slowly loosen and remove the retract (1) hose from the compensation cylinder.
4. Install a tee fitting to the retract (1) port of the compensation cylinder. Reconnect the previously removed retract (1) hose to the tee fitting.
5. Slowly loosen and remove the extend (2) hose from the compensation cylinder.
6. Install a tee fitting to the extend (2) port of the compensation cylinder. Reconnect the previously removed extend (2) hose to the tee fitting and cap the open port.



7. Install a digital or a 5000 psi (345 bar) gauge to the retract (1) port tee fitting on the compensation cylinder.
8. Start the machine and warm the hydraulic system to operating temperature.
9. Tilt the forks down to allow the tilt cylinder to fully retract.
10. Monitor the gauge and slowly raise the boom. The gauge should read:
TL642: 4150 - 4450 psi (286,5 - 306,5 bar)
TL943: 3911 - 4211 psi (270 - 290 bar)
11. If pressure is correct, proceed to step 14.
12. The relief on the (A) port is non-adjustable and must be replaced. Replace and repeat steps 9 and 10.
13. Verify pressure is correct.
14. Shut engine OFF.
15. Remove the digital or the 5000 psi (345 bar) gauge from the retract (1) port tee fitting on the compensation cylinder and cap the open port.
16. Remove the cap and install a digital or a 5000 psi (345 bar) gauge to the extend (2) port tee fitting on the compensation cylinder.
17. Start the machine and if needed, warm the hydraulic system to operating temperature.
18. Tilt the forks up to allow the tilt cylinder to fully extend.
19. Monitor the gauge and slowly lower the boom. The gauge should read:
TL642: 4150 - 4450 psi (286,5 - 306,5 bar)
TL943: 3911 - 4211 psi (270 - 290 bar)
20. If pressure is correct, proceed to step 23.
21. The relief on the (B) port is non-adjustable and must be replaced. Replace and repeat steps 17 and 18.
22. Verify pressure is correct.
23. Shut engine OFF.
24. Slowly remove the gauge, line and tee fitting from the compensation cylinder (1 & 2). Reinstall each hose and torque as required.
25. Install any previously removed attachment.

TL642

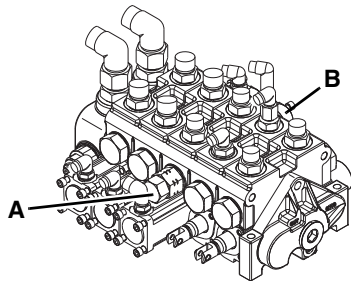

BEFORE S/N TBL01599

TL943

S/N TBL01599 & AFTER

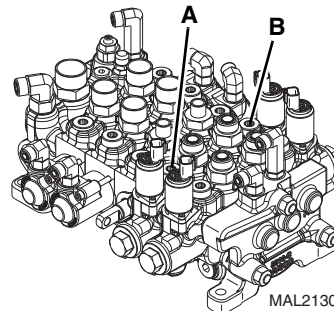
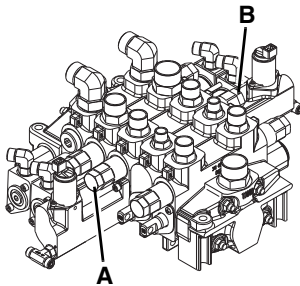

MAL2130

12. The relief on the (A) port is non-adjustable and must be replaced. Replace and repeat steps 9 and 10.
13. Verify pressure is correct.
14. Shut engine OFF.
15. Remove the digital or the 5000 psi (345 bar) gauge from the retract (1) port tee fitting on the compensation cylinder and cap the open port.
16. Remove the cap and install a digital or a 5000 psi (345 bar) gauge to the extend (2) port tee fitting on the compensation cylinder.
17. Start the machine and if needed, warm the hydraulic system to operating temperature.
18. Tilt the forks up to allow the tilt cylinder to fully extend.



Hydraulic System

c. Pressure Specifications - TL642

Note: All pressures must be checked in numerical order.

	Hydraulic Circuit	Test Port	Function Used to Test	Adjustment Location	Pressure Range
1	Pilot Pressure	BV (A)	High Idle - Bottom Steering, Any Mode	2	400 - 460 psi (30,3 - 31,7 Bar)
2	Relief Valve Cartridge	CF1 (C)	High Idle - Bottom Steering, Any Mode	1	2550 - 2650psi (176 - 183 Bar)
3	Main Relief Valve	EF1 (D)	High Idle - Bottom Boom Retract	3	3900 - 4100 psi (269 - 282,7 Bar)
4	Boom Extend	EF1 (D)	High Idle - Bottom Boom Extend	N/A	3650 - 3950 psi (251,6 - 272Bar)
5	Boom Lift	EF1 (D)	High Idle - Bottom Boom Down	N/A	3900 - 4100 psi (269 - 282,7 Bar)
6	Auxiliary	EF1 (D)	High Idle - Bottom Auxiliary Function	N/A	2850 - 3150 psi (196,5 - 217 Bar)

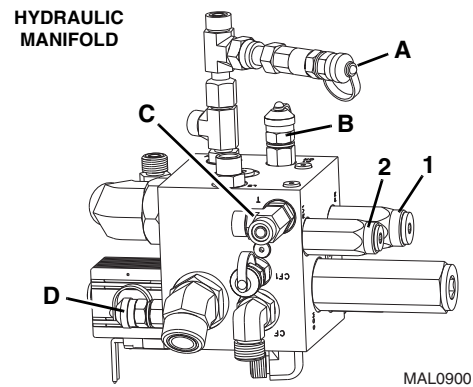
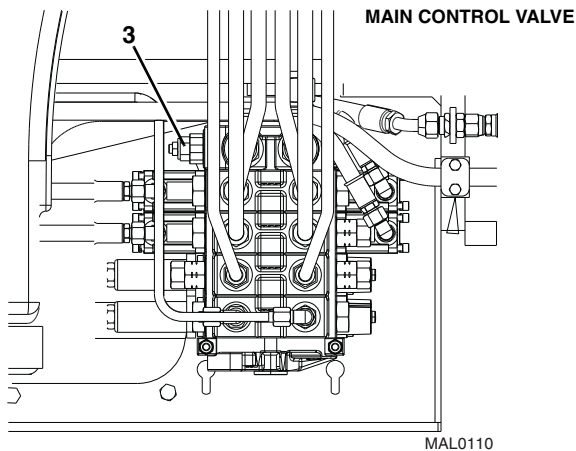



d. Pressure Specifications - TL943 Before S/N TBL01599 excluding TBL01551 & TBL01585

Hydraulic Circuit	Test Port	Procedure	Adjustment Location	Pressure Range
Park Brake Pilot	TP (A)	Connect gauge to TP port, run engine at high idle	6	500 ± 50 psi (34,5 ± 3,4 Bar)
Steering	Primary (B)	Connect gauge to Primary port, run engine at high idle, bottom out function. Hold over relief and check pressure.	7	2450 ± 100 psi (168,9 ± 6,6 Bar)
Service Brake	P1 (C)	Connect gauge to P1 port, run engine at high idle, depress brake pedal. Hold over relief and check pressure.	8	1100 ± 10 psi (75,8 ± 0,7 Bar)
Boom Lift Extend/Retract Frame Level Fork Tilt	Secondary (D)	Connect gauge to Secondary port, run engine at high idle, bottom out function. Hold over relief and check pressure.	9	3800 ± 50 psi (262,0 ± 13,4 Bar)

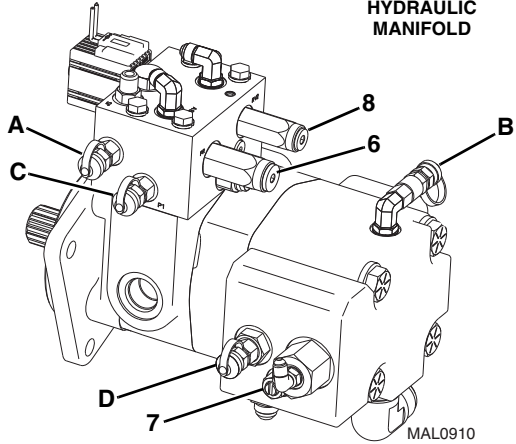
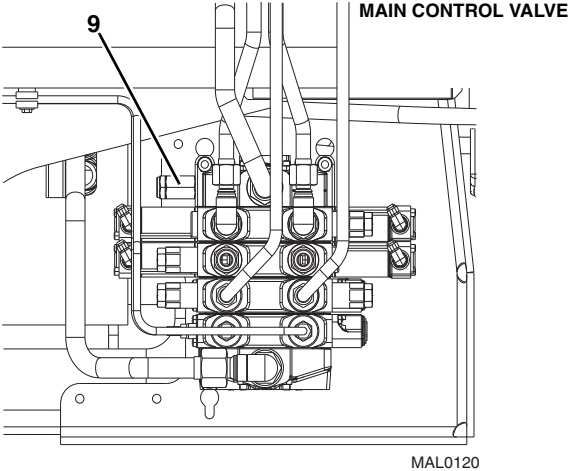



Hydraulic System

e. Pressure Specifications - TL943 S/N TBL01599 & After including TBL01551 & TBL01585

Note: 1. All pressures must be checked in numerical order.

Note: 2. Connect gauge to P1 port, adjust Standby Pressure to 250 psi (step 2). Adjust Main Compensator Pressure to 3950 psi (step 3). Adjustment may require incrementally increasing Load Sense Relief Valve (adjustment location 6) and Main Pump Compensator until a setting of 3950 psi can be observed on the gauge. Connect additional gauge to GLS (A) port, bottom boom lift, adjust Load Sense Relief to the setting noted below.

	Hydraulic Circuit	Test Port	Function Used to Test	Adjustment Location	Pressure Range
1	Load Sense Relief	GLS/PLS (A)	Bottom Boom Lift (see Note 2)	6	3550 - 3650 psi (245 - 252 Bar)
2	Standby	P1 (B)	High Idle - No Function	1	250 - 265 psi (17,2 - 18,3 Bar)
3	Main	P1 (B)	High Idle - Bottom Boom Lift	2	3825 - 3875 psi (264 - 267 Bar)
4	Pilot	JS1 (C)	High Idle - Bottom Steering, Any Mode	4	500 - 550 psi (34,5 - 38 Bar)
5	Service Brake	BV1 (D)	High Idle - Bottom Steering, Any Mode	5	1050 - 1150 psi (72,4 - 79,3 Bar)
6	Priority Load Sense	GLS/PLS (A)	High Idle - Bottom Steering, Any Mode	3	2350 - 2450 psi (162 - 169 Bar)
7	Boom Extend	GLS/PLS (A)	High Idle - Bottom Boom Extend	No Adjustment	3600 - 3800 psi (248 - 262 Bar)
8	Boom Retract	GLS/PLS (A)	High Idle - Bottom Boom Retract	No Adjustment	3600 - 3800 psi (248 - 262 Bar)
9	Boom Lift	GLS/PLS (A)	High Idle - Bottom Boom Lift	No Adjustment	3600 - 3800 psi (248 - 262 Bar)
10	Auxiliary	GLS/PLS (A)	High Idle - Bottom Auxiliary Function	No Adjustment	2900 - 3100 psi (200 - 214 Bar)

MAIN CONTROL VALVE

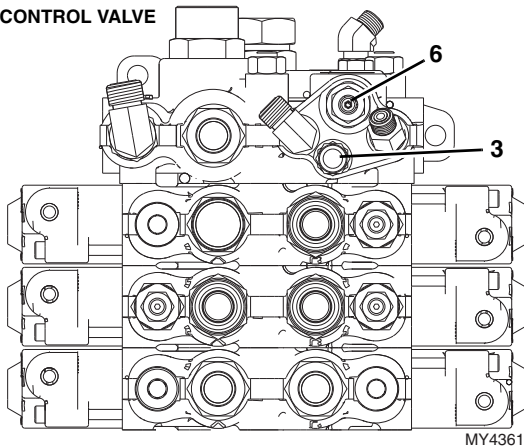

HYDRAULIC MANIFOLD

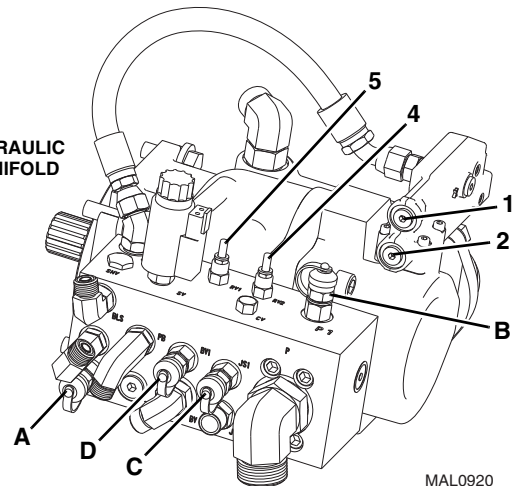



8.4.3 Hydraulic Schematic - TL642

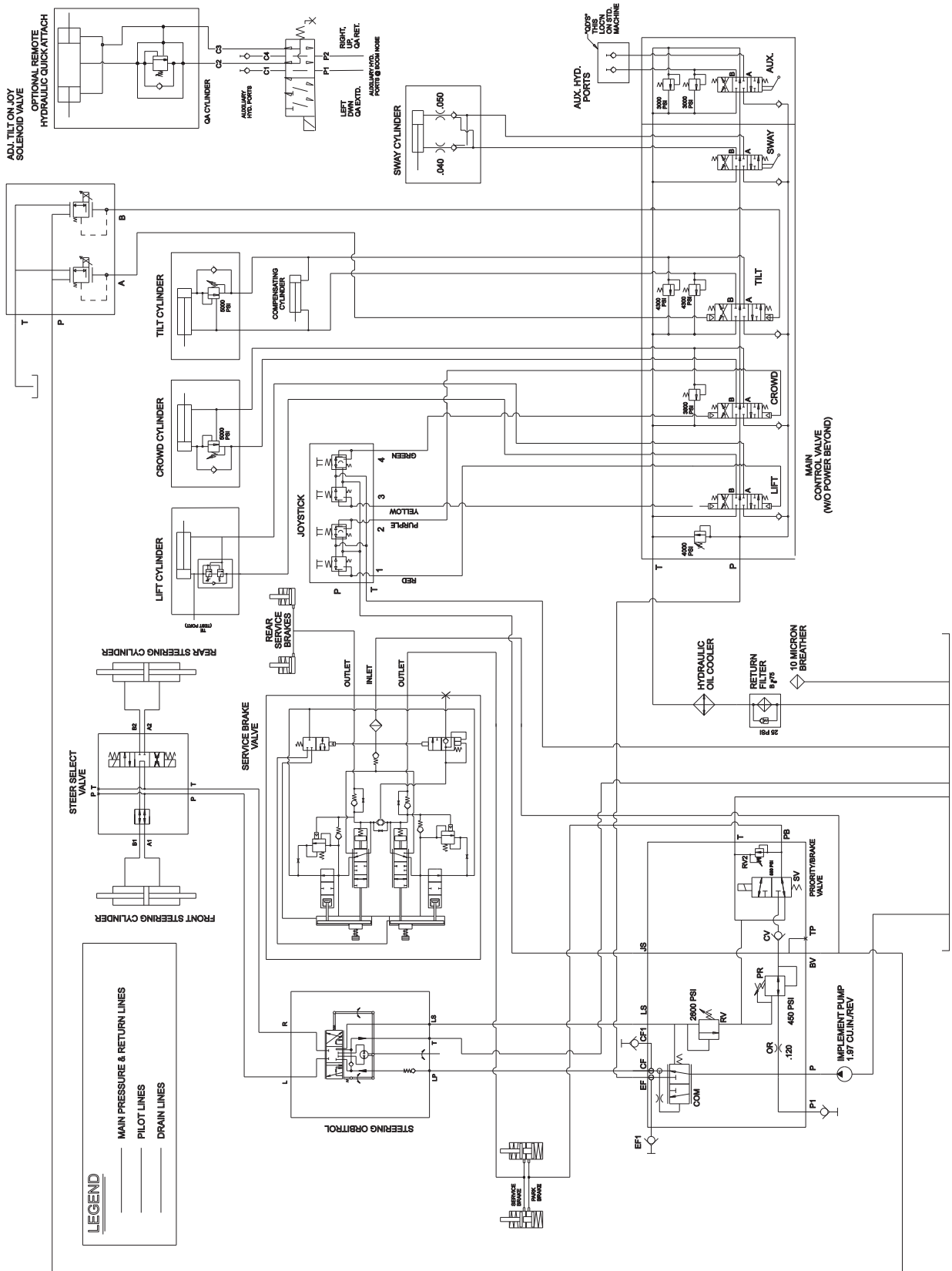

MAL0020J



Hydraulic System

8.4.3 Hydraulic Schematic - TL642 (Continued)

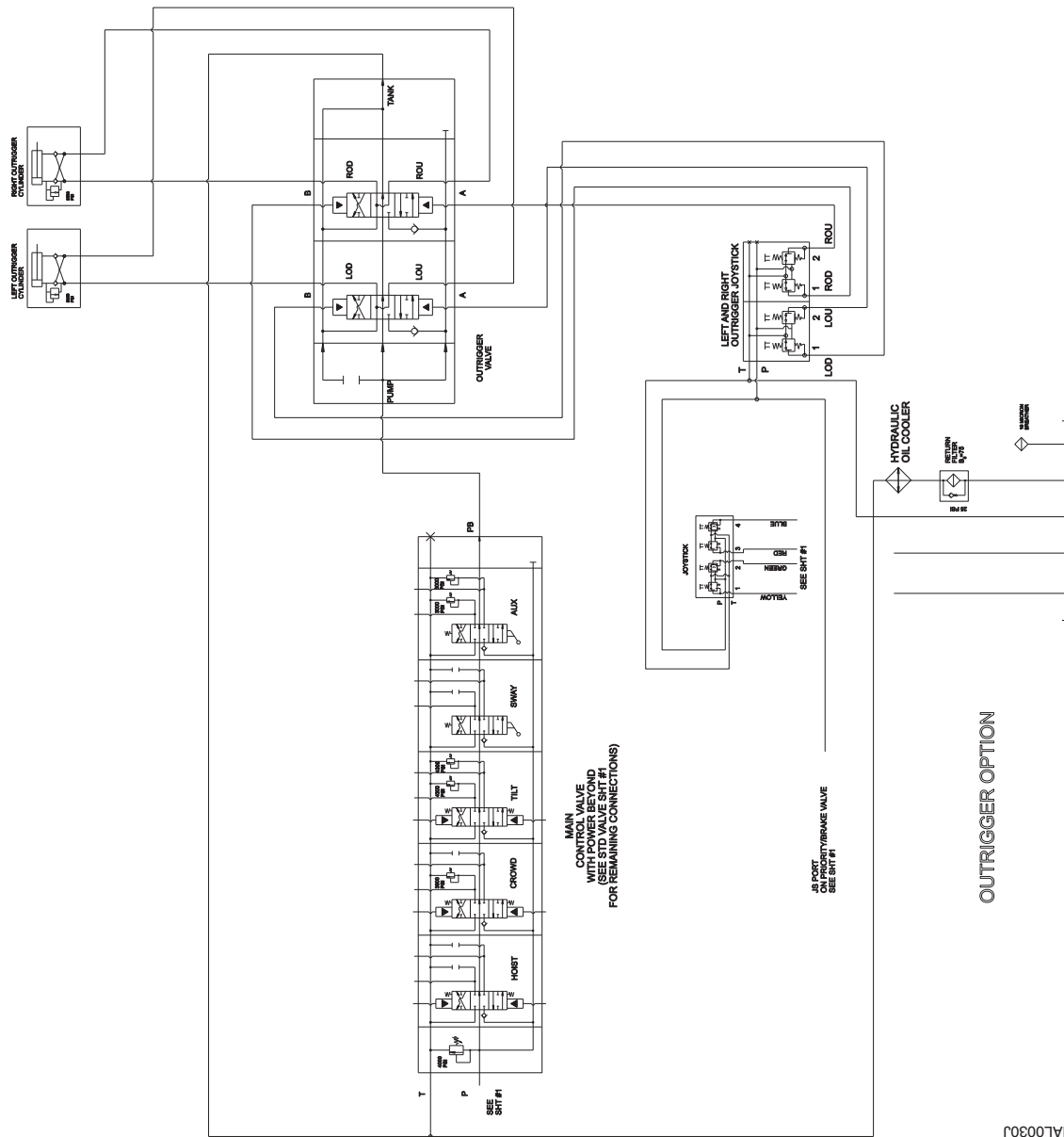

MAL0030J



8.4.4 Hydraulic Schematic - TL943 Before S/N TBL01599 excluding TBL01551 & TBL01585

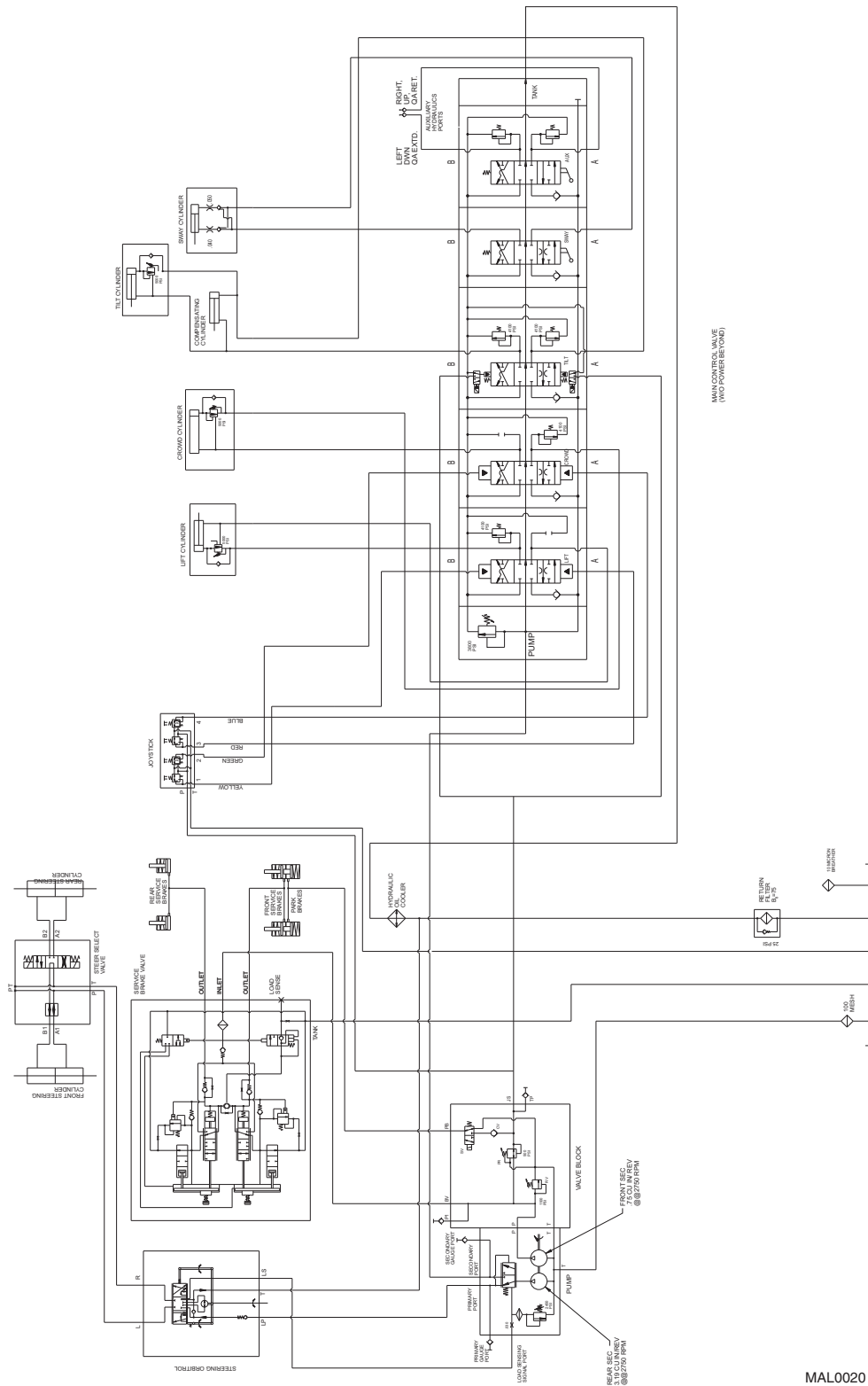

MAL0020



8.4.5 Hydraulic Schematic - TL943 S/N TBL01599 & After including TBL01551 & TBL01585

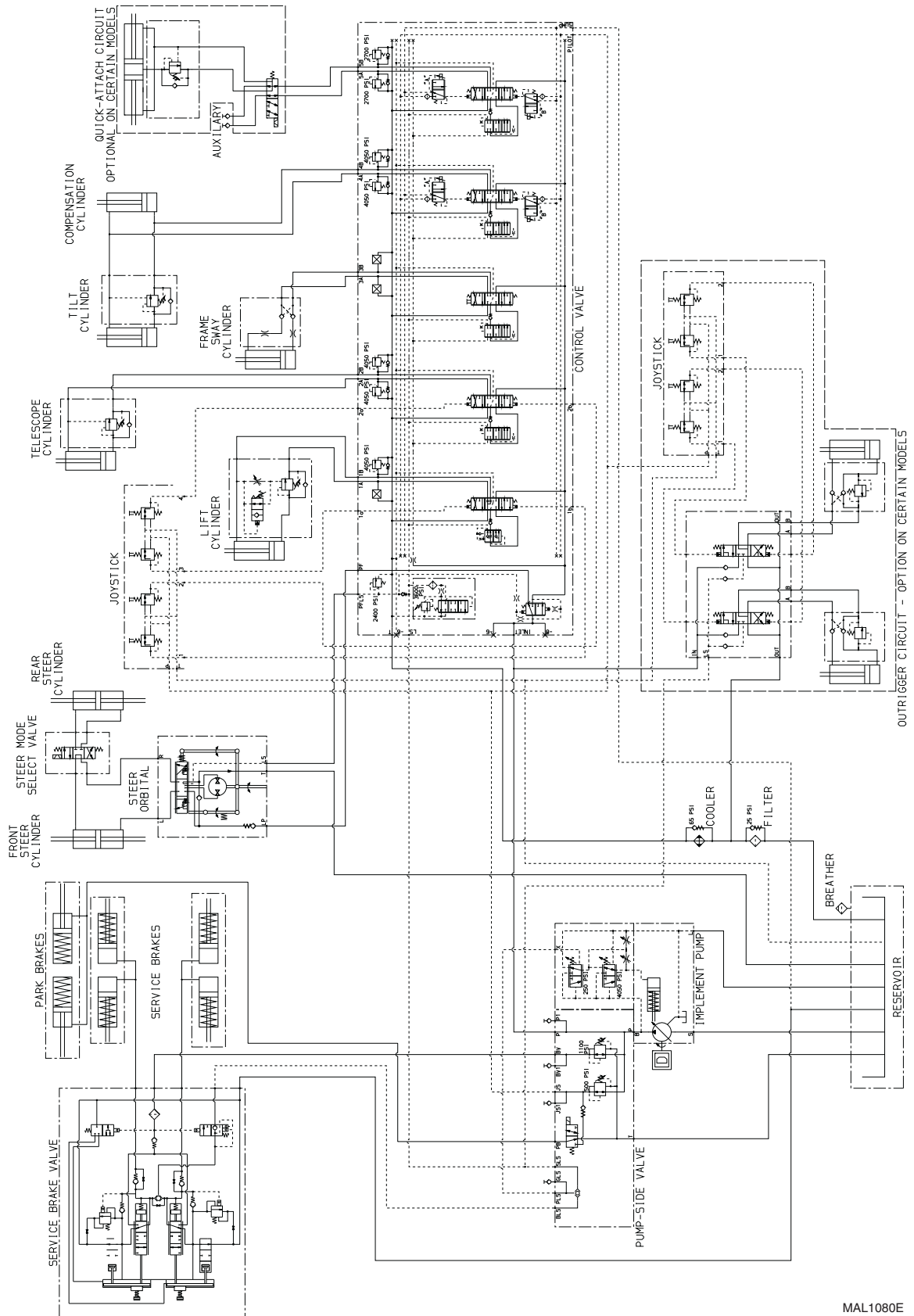

MAL1080E



8.5 HYDRAULIC RESERVOIR

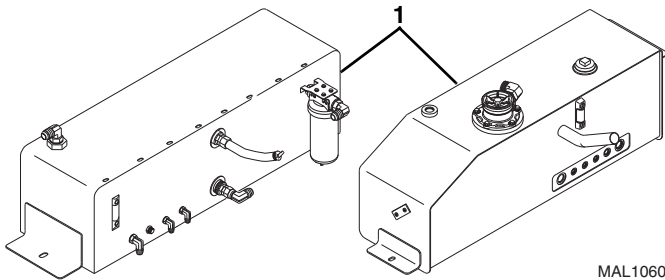

MAL1060

The hydraulic reservoir (1) is located on the frame between the engine compartment and the cab.

8.5.1 Hydraulic Oil Reservoir Draining

1. Park the machine on a firm, level surface, level the machine, fully retract the boom, lower the boom, place the transmission control lever in (N) NEUTRAL, engage the park brake and shut the engine OFF.
2. Place a Do Not Operate Tag on both the ignition key switch and the steering wheel, stating that the machine should not be operated.
3. Open the engine cover. Allow the system fluids to cool.
4. Properly disconnect the battery.
5. Open the filler cap on the hydraulic oil reservoir. Remove the drain plug on the side of the hydraulic oil reservoir.
6. Transfer the used hydraulic oil into a suitable covered container, and label as "Used Oil". Dispose of used oil at an approved recycling facility. Clean and reinstall the drain plug.
7. Wipe up any hydraulic fluid spillage in, on, near and around the machine and the work area.

8.5.2 Hydraulic Oil Reservoir Filling

1. Be sure the reservoir is clean and free of all debris.
2. Install a new hydraulic oil filter.
3. Fill the reservoir with hydraulic oil. Refer to Section 2.4, "Fluids and Lubricant Capacities."
4. Properly connect the battery.
5. Close and secure the engine cover.
6. Remove the Do Not Operate Tags from both the ignition key switch and the steering wheel.

8.5.3 Hydraulic Oil Reservoir Removal/Installation

If it is determined that the hydraulic oil reservoir must be removed, the hydraulic oil must be drained before the reservoir is removed. Always dispose of hydraulic oil properly.

a. Reservoir Removal

1. Park the machine on a firm, level surface, level the machine, fully retract the boom, lower the boom, place the transmission control lever in (N) NEUTRAL, engage the park brake and shut the engine OFF.
2. Place a Do Not Operate Tag on both the ignition key switch and the steering wheel, stating that the machine should not be operated.
3. Open the engine cover. Allow the system fluids to cool.
4. Properly disconnect the battery.
5. Drain the hydraulic oil reservoir. Refer to Section 8.5.1, "Hydraulic Oil Reservoir Draining."
6. Label, disconnect and cap all hydraulic hoses attached to the hydraulic oil reservoir. Cap all fittings and openings to keep dirt & debris from entering the hydraulic system.
7. Remove the bolts securing the hydraulic oil reservoir to the frame.
8. Remove the hydraulic oil reservoir.

b. Disassembly

The hydraulic oil reservoir is a one-piece unit and cannot be disassembled. The hydraulic oil level sight-glass and hydraulic oil filler cap can be removed and reused on the new replacement reservoir. Dispose of the old reservoir according to local regulations concerning hazardous materials disposal.

c. Cleaning and Drying

If contaminated hydraulic oil or foreign material is in the tank, the tank can usually be cleaned.

Note: If a leak is suspected in the hydraulic oil reservoir, contact your local Service Department.



To clean the hydraulic oil reservoir:

1. Have a dry chemical (Class B) fire extinguisher near the work area.
2. Remove the hydraulic oil reservoir drain plug, and safely drain any hydraulic oil into a suitable container. Dispose of hydraulic oil properly.
3. Clean the hydraulic oil reservoir with a high-pressure washer, or flush the tank with hot water for five minutes and drain the water. Dispose of contaminated water properly.

d. Inspection

Note: If a leak is suspected in the fuel or hydraulic oil tank, contact your local Service Department.

1. Inspect the hydraulic oil reservoir thoroughly for any cracks, slices, leaks or other damage.
2. With the hydraulic oil reservoir removed from the machine, plug all openings except one elbow fitting. Install the elbow fitting, and apply approximately 1-1.5 psi (7-10 kPa) of air pressure through the elbow. Check the reservoir for leaks by applying a soap solution to the exterior and look for bubbles to appear at the cracked or damaged area.

e. Reservoir Installation

1. Place the hydraulic oil reservoir into its original orientation.
2. Secure the hydraulic oil reservoir to the frame with the previous mounting hardware.
3. Uncap and connect the previously labeled hydraulic hoses to their appropriate locations.
4. Install the hydraulic fluid level sight-glass using special designed and drilled capscrews and gaskets.
5. Install hydraulic filter bracket and hydraulic filter.
6. Fill the hydraulic oil reservoir according to specifications. Refer to Section 2.4, "Fluids and Lubricant Capacities."
7. Check the hydraulic oil reservoir for leaks.
8. Properly connect the battery
9. Close and secure the engine cover.
10. Remove the Do Not Operate Tags from both the ignition key switch and the steering wheel.

8.6 ENGINE IMPLEMENT PUMP

For internal service instructions contact your local distributor.

8.6.1 Pump Replacement

TL642 - All

TL943 - Before S/N TBL01599 excluding TBL01551 & TBL01585

a. Pump Removal

1. Park the machine on a firm, level surface, level the machine, fully retract the boom, lower the boom, place the transmission control lever in (N) NEUTRAL, engage the park brake and shut the engine OFF.
2. Place a Do Not Operate Tag on both the ignition key switch and the steering wheel, stating that the machine should not be operated.
3. Open the engine cover. Allow the system fluids to cool.
4. Properly disconnect the battery.
5. Drain the hydraulic reservoir. Refer to Section 8.5.1, "Hydraulic Oil Reservoir Draining."

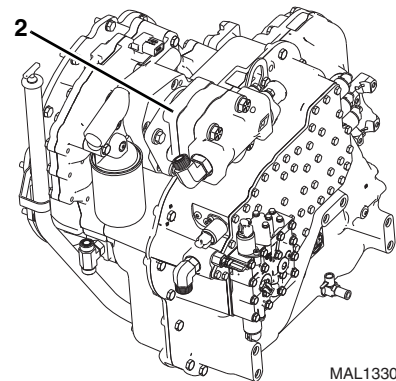

6. Thoroughly clean the pump (2) and surrounding area, including all hoses and fittings before proceeding.

Note: Cap all hoses as you remove them to prevent unnecessary fluid spillage.

7. Label, disconnect and cap the hydraulic hoses attached to the pump.
8. Remove the three bolts and washers securing the pump to the transmission. Remove the o-ring located between the transmission and the pump. Wipe up any hydraulic oil spillage.



Hydraulic System

b. Pump Installation

1. Place the pump and a new, oiled o-ring into position on the transmission. Align the pump shaft with the internal transmission gear, so that the machined teeth mesh together.
2. Align the bolt holes with the pump mount holes. Secure the pump to the transmission with the three bolts and washers. Torque as required.
3. Uncap and connect the previously labeled hydraulic hoses to their appropriate locations.
4. Fill the hydraulic reservoir. Refer to Section 8.5.2, "Hydraulic Oil Reservoir Filling."
5. Prime the pump by filling the case drain port with fresh, filtered hydraulic oil from a clean container before installing the case drain connector and hose.
6. Check all routing of hoses and tubing for sharp bends or interference with any rotating members. All tube and hose clamps must be tight.
7. Properly connect the battery.
8. Start the engine and run at approximately one-third to one-half throttle for about one minute without moving the machine or operating any hydraulic functions.
9. Inspect for leaks and check all fluid levels. The hydraulic reservoir oil level must be to the middle of the sight gauge.
10. Close and secure the engine cover.
11. Remove the Do Not Operate Tags from both the ignition key switch and the steering wheel.

c. Pump Test

Refer to Section 8.3.1, "Pressure Checks and Adjustments."

TL943 - S/N TBL01599 & After including TBL01551 & TBL01585

a. Pump Removal

1. Park the machine on a firm, level surface, level the machine, fully retract the boom, lower the boom, place the transmission control lever in (N) NEUTRAL, engage the park brake and shut the engine OFF.
2. Place a Do Not Operate Tag on both the ignition key switch and the steering wheel, stating that the machine should not be operated.
3. Open the engine cover. Allow the system fluids to cool.
4. Properly disconnect the battery.

5. Drain the hydraulic reservoir. Refer to Section 8.5.1, "Hydraulic Oil Reservoir Draining."

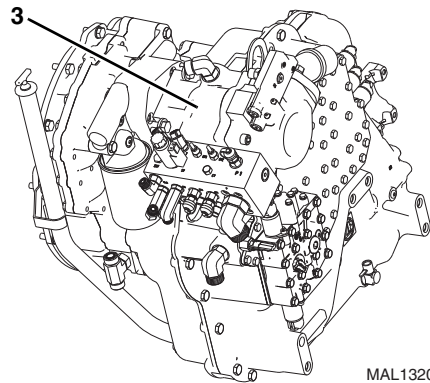

6. Thoroughly clean the pump (3) and surrounding area, including all hoses and fittings before proceeding.

Note: Cap all hoses as you remove them to prevent unnecessary fluid spillage.

7. Label, disconnect and cap the hydraulic hoses attached to the pump.
8. Remove the four bolts and lockwashers securing the pump to the transmission. Remove the o-ring located between the transmission and the pump. Wipe up any hydraulic oil spillage.

b. Pump Installation

1. Place the pump and a new, oiled o-ring into position on the transmission. Align the pump shaft with the internal transmission gear, so that the machined teeth mesh together.
2. Align the bolt holes with the pump mount holes. Secure the pump to the transmission with the four bolts and washers. Torque as required.
3. Uncap and connect the previously labeled hydraulic hoses to their appropriate locations.
4. Fill the hydraulic reservoir. Refer to Section 8.5.2, "Hydraulic Oil Reservoir Filling."
5. Check all routing of hoses and tubing for sharp bends or interference with any rotating members. All tube and hose clamps must be tight.

Note: The following priming procedure **MUST** be followed whenever the implement pump has been replaced.



c. Pump Priming

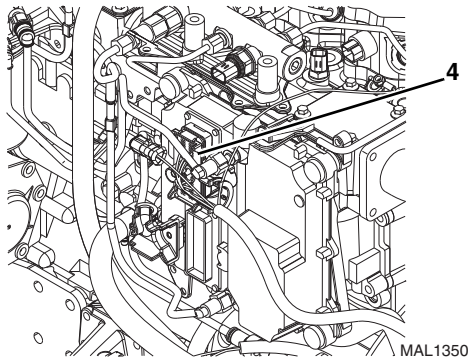

1. Disconnect the electrical connector (4) from the engine ECM.
2. Properly connect the battery.

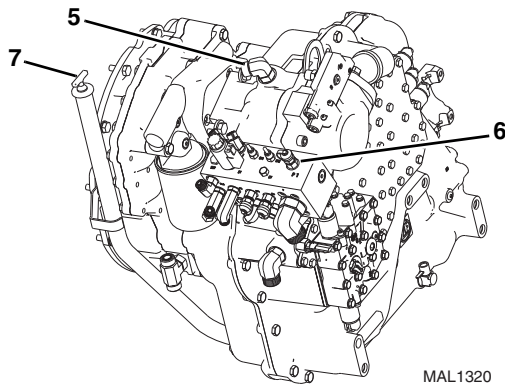

3. Loosen and remove the hose (5) from the fitting on the upper case drain port "L1" on the piston pump and allow hydraulic oil to fill the case.
4. Install the previously removed hose to the fitting on the upper case drain port "L1" on the piston pump.
5. Connect one end of a test gauge hose to test port at the "P1" location on the pump manifold block (6).
6. Remove the transmission dipstick (7) and put the open end of the test gauge hose into the dipstick tube.
7. Turn the ignition key to start and crank the engine in 20 second intervals until a continuous stream of hydraulic oil flows from the test gauge hose.
8. The pump is now primed.
9. Remove the test gauge hose from the "P1" location on the pump manifold block (6).
10. Replace the previously removed transmission dipstick (7).
11. Connect the electrical connector to the engine ECM (4).

12. Start the engine and run at approximately one-third to one-half throttle for about one minute without moving the machine or operating any hydraulic functions.
13. Inspect for leaks and check all fluid levels. The hydraulic reservoir oil level must be to the middle of the sight gauge.
14. Close and secure the engine cover.
15. Remove the Do Not Operate Tags from both the ignition key switch and the steering wheel.

d. Pump Test

Refer to Section 8.3.1, "Pressure Checks and Adjustments."



8.7 CONTROL VALVES

8.7.1 Main Control Valve

The main control valve is mounted on the frame behind the cab underneath a protective cover.

The main control valve assembly consists of separate working sections with their own valve assemblies, each providing a specific hydraulic function.

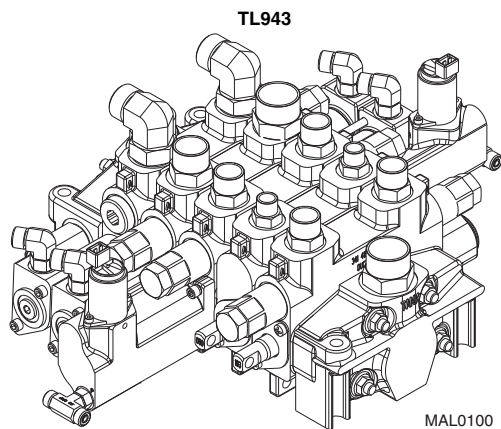
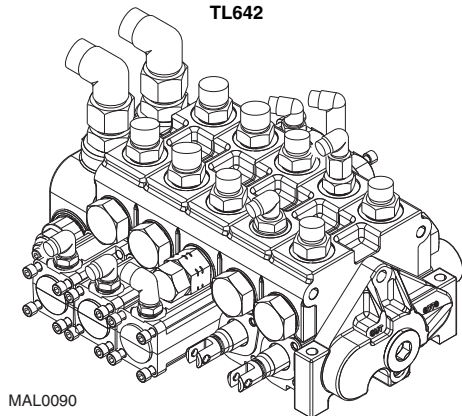

a. Main Control Valve Removal

1. Park the machine on a firm, level surface, level the machine, fully retract the boom, lower the boom, place the transmission control lever in (N) NEUTRAL, engage the park brake and shut the engine OFF.
2. Place a Do Not Operate Tag on both the ignition key switch and the steering wheel, stating that the machine should not be operated.
3. Open the engine cover. Allow the system fluids to cool.
4. Properly disconnect the battery.
5. Remove the main control valve protective cover.

6. Thoroughly clean the main control valve and surrounding area, including all hoses and fittings, before proceeding.
7. Drain the hydraulic fluid reservoir. Refer to Section 8.5.1, "Hydraulic Oil Reservoir Draining."
8. Place a suitable container to catch hydraulic fluid drainage beneath the frame.

Note: *Slowly remove the hydraulic hoses attached to the main control valve to relieve any possible trapped pressure in the hydraulic line.*

9. Label, disconnect and cap all the hydraulic hoses, tubes and wires at the main control valve.
10. Wipe up any hydraulic fluid spillage in, on, near and around the machine and the work area.
11. Remove the three bolts, washer and nuts (3) securing the main control valve to the frame.

b. Main Control Valve Disassembly

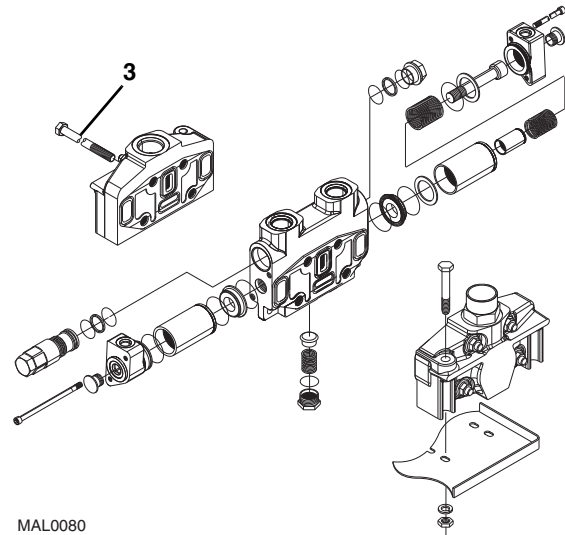

1. To disassemble the individual sections of the main control valve, remove the nuts from one end of the tie rods (3). Pull the tie rods out through the sections.

2. Disassemble each section assembly as required.

Some sections include a pre-adjusted relief valve that regulates pressure in a specific circuit.

Note: *DO NOT adjust any of the relief valve assemblies! Tampering with a relief valve will irrevocably alter pressure in the affected circuit, requiring recalibration or a new relief valve.*



Disassemble each Valve Section

1. Carefully separate the load sense outlet section from the lift/lower section.
2. Remove the o-rings from between the two sections.
3. Carefully separate each remaining sections, being careful not to lose the load sense shuttle ball.
4. Remove both end caps from each end of the valve sections then remove each control spool.
5. Remove any check valves, compensator valves, anti-cavitation valves or shock valves from individual valve section if equipped.
6. Keep all parts being removed from individual valve sections tagged and kept together.

c. Main Control Valve Parts Cleaning

Clean all components with a suitable cleaner, such as trichlorethylene, before continuing. Blow dry.

d. Main Control Valve Parts Inspection

Inspect all parts and internal passageways for wear, damage, etc. If inner surfaces of any component **DO NOT** display an ultra-smooth, polished finish, or are damaged in any way, replace the damaged part. Often, dirty hydraulic fluid causes failure of internal seals, damage to the polished surfaces within the component, and wear of and/or harm to other parts.

e. Main Control Valve Assembly

Note: ALWAYS replace seals, o-rings, gaskets, etc., with new parts to help ensure proper sealing and operation. Lubricate seals and o-rings with clean hydraulic oil.

Assemble each Valve Section

1. Reassemble any check valves, compensator valves, anti-cavitation valves or shock valves from each individual valve section if equipped.
2. Install the control spool being careful not to nick or scratch the valve section bore or the control spool.
3. Install the end caps on each end of the valve section.

Assemble the Main Control Valve.

1. Place all three tie rods with the washers and nuts through the end main control valve section.
2. Stand the end main control valve section on end.

3. Install the proper o-rings and load sense shuttle on the inner face of the end main control valve section. Align the next valve section over the three tie rods and slide onto the end main control valve section.
4. Using the proper o-rings and load sense shuttle, repeat step three for the remaining valve sections and lastly the inlet end valve section.
5. Install the three washers and nuts on the tie rods. Torque to 32 lb-ft (43 Nm) for the TL642 and to 42 lb-ft (57 Nm) for the TL943.

f. Main Control Valve Installation

1. Install the main control valve onto the frame, aligning the bolts with the holes in the end sections of the main control valve. Slide the main control valve into position, and tighten the bolts.
2. Prime the main control valve by filling the inlet openings with fresh, filtered hydraulic oil from a clean container, before attaching the hoses.
3. Use new oiled o-rings as required. Uncap and connect all previously labeled hoses, clamps, etc. to the main control valve.
4. Check the routing of all hoses, wiring and tubing for sharp bends or interference with any rotating members, and install tie wraps and/or protective conduit as required. Tighten all tube and hose clamps.
5. Fill the hydraulic fluid reservoir. Refer to Section 8.5.2, "Hydraulic Oil Reservoir Filling."
6. Properly connect the battery.
7. Start the engine and run at approximately one-third to one-half throttle for about one minute without moving the machine or operating any hydraulic functions.
8. Inspect for leaks and check the level of the hydraulic fluid in the reservoir. Shut the engine OFF.

Note: Check for leaks and repair as required before continuing. Add hydraulic fluid to the reservoir as needed.

9. Wipe up any hydraulic fluid spillage in, on, near and around the machine, work area and tools.
10. Install the main control valve protective cover.
11. Close and secure the engine cover.
12. Remove the Do Not Operate Tags from both the ignition key switch and the steering wheel.



Hydraulic System

g. Main Control Valve Test

Conduct a pressure check of the hydraulic system in its entirety. Adjust pressure(s) as required. Refer to Section 8.3.1, "Pressure Checks and Adjustments."

8.7.2 Service Brake Valve

a. Service Brake Valve Removal

1. Park the machine on a firm, level surface, level the machine, fully retract the boom, lower the boom, place the transmission control lever in (N) NEUTRAL, engage the park brake and shut the engine OFF.
2. Place a Do Not Operate Tag on both the ignition key switch and the steering wheel, stating that the machine should not be operated.
3. Open the engine cover. Allow the system fluids to cool.
4. Properly disconnect the battery.
5. Label, disconnect and cap all hose attached to the service brake valve.
6. Remove the service brake pedal. Refer to Section 4.3.2, "Service Brake Pedal."

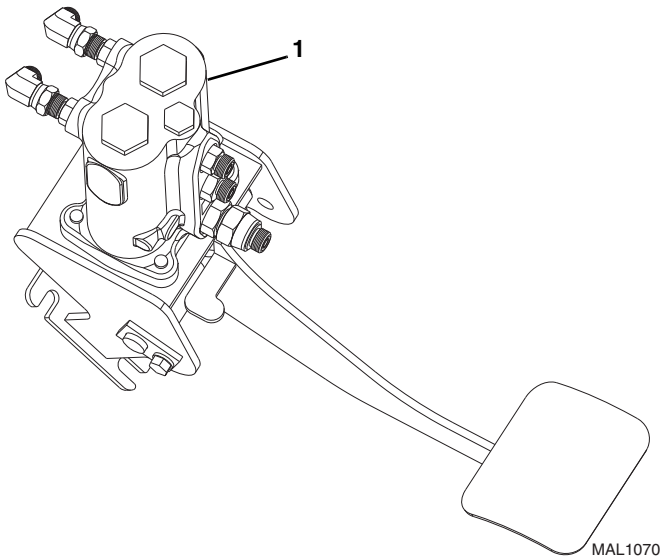

7. Remove the four capscrews, four nuts and four lockwashers mounting the service brake valve (1) to the service brake bracket.

Note: *DO NOT* disassemble the service brake valve. The service brake valve is not serviceable and must be replaced in its entirety, if defective.

b. Service Brake Valve Installation

1. Install the service brake valve with the four capscrews, four lockwashers and four nuts onto the service brake bracket.
2. Install the service brake pedal. Refer to Section 4.3.2, "Service Brake Pedal."

Note: *ALWAYS* replace seals, o-rings, gaskets, etc., with new parts to help ensure proper sealing and operation. Lubricate seals and o-rings with clean hydraulic oil.

3. Use new oiled o-rings as required. Uncap and connect the previously labeled hoses to the service brake valve.
4. Check the routing of all hoses, and tubing for sharp bends or interference with any rotating members, and install tie wraps and/or protective conduit as required. Tighten all tube and hose clamps.
5. Properly connect the battery.
6. Start the engine and run at approximately one-third to one-half throttle for about one minute, without moving the machine or operating any hydraulic functions.
7. Inspect the service brake valve and connections for leaks, and check the level of the hydraulic fluid in the reservoir. Shut the engine OFF.

Note: *Check for leaks, and repair as required before continuing. Add hydraulic fluid to the reservoir as needed.*

8. Wipe up any hydraulic fluid spillage in, on, near and around the machine, work area and tools.
9. Close and secure the engine cover.
10. Remove the Do Not Operate Tags from both the ignition key switch and the steering wheel.



8.7.3 Brake Test

Carefully bleed the brake lines as soon as the brake valve is installed in the machine. Air in the system will not allow the brakes to apply properly. There are four brake bleeder locations on the axles. Work with an assistant to perform this procedure.

1. Place the travel select lever in (N) NEUTRAL, engage the park brake, and start the engine.

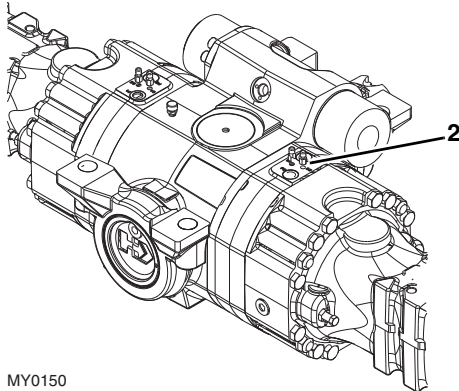

MY0150

2. Remove the plastic cap from the brake bleeder (2). Attach one end of a length of transparent tubing over the brake bleeder. Place the other end of this tubing in a suitable transparent container that is partially filled with hydraulic oil. The end of the tubing must be below the oil level in the container.
3. **DO NOT** open the brake bleeder without holding the tubing firmly on the bleeder. There is pressure at the brakes. Carefully open the bleeder with a 12 mm wrench. Have the assistant depress the brake pedal. Close the brake bleeder when air bubbles no longer appear in the oil. Release the brake pedal. Remove the tubing from the brake bleeder.
4. Repeat Steps 2 and 3 for the remaining brake bleeders.
5. Install a vacuum pump on the brake reservoir and remove the remainder of the trapped air from the brake system.
6. Check brake fluid level and add fluid if necessary.
7. Conduct a pressure and function check of the service brake. Refer to Section 8.4.1, "Hydraulic Pressures."

8.7.4 Steering Orbitrol Valve

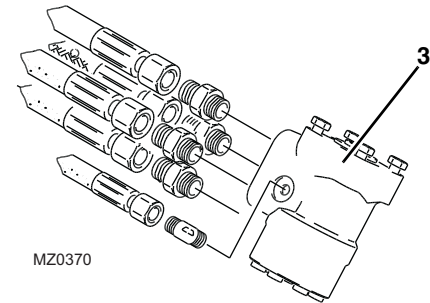

MZ0370

The steering orbitrol valve (3) is located at the base of the steering wheel shaft, concealed by the lower dash cover. The valve is not serviceable and must be replaced in its entirety if defective. For detailed information refer to Section 4.3.1, "Steering Column and Orbitrol Valve."



8.7.5 Steer Select Valve

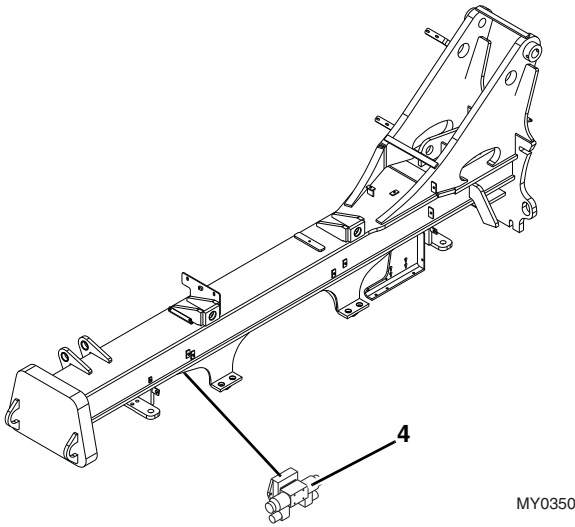

The machine can be used in the front-wheel, four-wheel or crab steering mode. The steer select valve (4) controls the direction of hydraulic fluid flow to the steering cylinder mounted on each axle. The steer select valve is attached to a mounting plate inside the frame near the left front corner of the cab.

Verify the correct operation of the steer select valve solenoids before considering replacement of the valve. Refer to Section 9.5, "Electrical System Schematics," and Section 9.12, "Gauges and Display Monitor." The housing of the steer select valve is not serviceable and must be replaced if defective.

a. Steer Select Manifold and Valve Removal

1. Park the machine on a firm, level surface, level the machine, fully retract the boom, lower the boom, place the transmission control lever in (N) NEUTRAL, engage the park brake and shut the engine OFF.
2. Place a Do Not Operate Tag on both the ignition key switch and the steering wheel, stating that the machine should not be operated.
3. Open the engine cover. Allow the system fluids to cool.
4. Properly disconnect the battery.
5. Label, disconnect and cap the hydraulic hoses and the electrical plugs connected to the steering select valve.
6. Remove the bolts holding the steer select valve to the mounting plate on the frame.
7. Remove the steer select manifold with the attached steer select valve from the machine.

8. Wipe up any hydraulic fluid spillage in, on, near and around the machine.

b. Steer Select Manifold and Valve Disassembly, Cleaning, Inspection and Assembly

1. Place the steer select assembly on a suitable work surface.
2. Separate the steer select valve from the manifold by removing the four socket head capscrews. Discard the four o-rings.
3. Remove the solenoid valves and cartridges from the steer select housing.
4. Clean all components with a suitable cleaner before inspection.
5. Inspect the solenoid cartridges for proper operation. Check by shifting the spool to ensure that it is functioning properly. Check that the spring is intact. Inspect the cartridge interior for contamination.
6. Inspect internal passageways of the steer select manifold and valve for wear, damage, etc. If inner surfaces of the manifold DO NOT display an ultra-smooth, polished finish, or components are damaged in any way, replace the manifold or appropriate part. Often, dirty hydraulic fluid causes failure of internal seals and damage to the polished surfaces within the secondary function manifold.

Note: ALWAYS replace seals, o-rings, gaskets, etc., with new parts to help ensure proper sealing and operation. Lubricate seals and o-rings with clean hydraulic oil.

7. Install the solenoid valves and cartridges in the steer select housing.
8. Attach the steer select valve to the manifold using four new, oiled o-rings and the four socket head capscrews.

c. Steer Select Valve and Manifold Installation

1. Install the steer select valve to the mounting plate under the left front side of the frame using the two bolts.
2. Connect all the hydraulic hoses, fittings, solenoid wire terminal leads, etc., to the steer select valve
3. Check the routing of all hoses, wiring and tubing for sharp bends or interference with any rotating members, and install tie wraps and/or protective conduit as required. Tighten all hose clamps.
4. Properly connect the battery.



5. Start the engine and run at approximately 1/3-1/2 throttle for about one minute without moving the machine or operating any hydraulic functions.
6. Inspect for leaks and check the level of the hydraulic fluid in the reservoir. Shut the engine OFF.

Note: Check for leaks and repair as required before continuing. Add hydraulic fluid to the reservoir as needed.

7. Wipe up any hydraulic fluid spillage in, on, near and around the machine, work area and tools.
8. Close and secure the engine cover.
9. Remove the Do Not Operate Tags from both the ignition key switch and the steering wheel.

d. Steering Test

Refer to Section 8.4.1, "Hydraulic Pressures."

1. Conduct a pressure check of the steering hydraulic circuit.
2. Check each steering mode for proper function.

8.7.6 Outrigger Valve (if equipped)

a. Outrigger Valve Removal

1. Park the machine on a firm, level surface, level the machine, fully retract the boom, raise the boom, place the transmission control lever in (N) NEUTRAL, engage the park brake and shut the engine OFF.
2. Place a Do Not Operate Tag on both the ignition key switch and the steering wheel, stating that the machine should not be operated.
3. Open the engine cover. Allow the system fluids to cool.
4. Properly disconnect the battery.

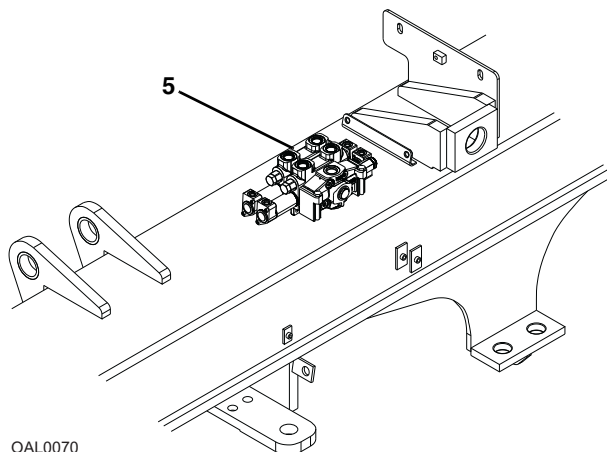

OAL0070

5. Remove the cover over the outrigger valve (5).
6. Label, disconnect and cap the hydraulic hoses connected to the outrigger control valve. Cap all fittings to keep dirt & debris from entering the hydraulic system.
7. Remove the bolts holding the outrigger control valve to the frame.

b. Outrigger Valve Installation

1. Install the outrigger valve onto the machine frame.
2. Uncap and connect the previously labeled hydraulic hoses to the outrigger valve.
3. Check the routing of all hoses, wiring and tubing for sharp bends or interference with any rotating members, and install tie wraps and/or protective conduit as required. Tighten all hose clamps.
4. Properly connect the battery.
5. Start the engine and run at approximately 1/3-1/2 throttle for about one minute without moving the machine or operating any hydraulic functions.
6. Inspect for leaks and check the level of the hydraulic fluid in the reservoir. Shut the engine OFF.

Note: Check for leaks and repair as required before continuing. Add hydraulic fluid to the reservoir as needed.

7. Wipe up any hydraulic fluid spillage in, on, near and around the machine, work area and tools.
8. Close and secure the engine cover.
9. Remove the Do Not Operate Tags from both the ignition key switch and the steering wheel.



8.8 HYDRAULIC CYLINDERS

8.8.1 General Cylinder Removal Instructions

1. Remove any attachment from the machine. Park the machine on a firm level surface and fully retract the boom. Allow sufficient work space around the hydraulic cylinder being removed. Support the boom if the lift/lower cylinder is being removed. Place the travel select lever in (N) NEUTRAL, engage the park brake, shut the engine OFF and chock wheels.
2. Place a Do Not Operate Tag on both the ignition key switch and the steering wheel, stating that the machine should not be operated.
3. Open the engine cover. Allow the system fluids to cool.
4. Label, disconnect and cap or plug hydraulic hoses in relation to the cylinder.
5. Attach a suitable sling to an appropriate lifting device and to the cylinder. Make sure the device used can actually support the cylinder.
6. Remove the lock bolt and/or any retaining clips securing the cylinder pins. Remove the cylinder pins.
7. Remove the cylinder.
8. Wipe up any hydraulic fluid spillage in, on, near and around the machine, work area and tools.

a. General Cylinder Disassembly

1. Clean the cylinder with a suitable cleaner before disassembly. Remove all dirt, debris and grease from the cylinder.

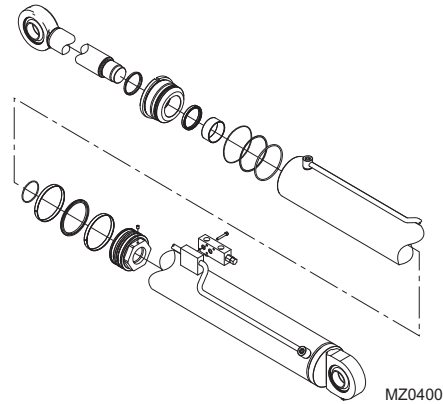

2. Clamp the barrel end of the cylinder in a soft-jawed vise or other acceptable holding equipment if possible.

WARNING

Significant pressure may be trapped inside the cylinder. Exercise caution when removing a counterbalance valve or a pilot-operated check valve from a cylinder.

Note: Avoid using excessive force when clamping the cylinder in a vise. Apply only enough force to hold the cylinder securely. Excessive force can damage the cylinder tube.

3. If applicable, remove the counterbalance valve from the side of the cylinder barrel.

Note: DO NOT tamper with or attempt to adjust the counterbalance valve cartridge. If adjustment or replacement is necessary, replace the counterbalance valve with a new part.

4. Extend the rod as required to allow access to the base of the cylinder.

Note: Protect the finish of the rod at all times. Damage to the surface of the rod can cause seal failure.

5. Using a pin spanner wrench, unscrew the head gland from the tube. A considerable amount of force will be needed to remove the head gland. Carefully slide the head gland down along the rod toward the rod eye, away from the cylinder barrel.



Note: When sliding the rod and piston assembly out of the barrel, prevent the threaded end of the barrel from damaging the piston. Keep the rod centered within the barrel to help prevent binding.

6. Carefully pull the rod assembly along with the head gland out of the cylinder barrel.
7. Fasten the rod eye in a soft-jawed vise, and place a padded support under and near the threaded end of the rod to prevent any damage to the rod.
8. Remove the set screw from the piston head.

Note: It may be necessary to apply heat to break the bond of the sealant between the piston and the rod before the piston can be removed.

Some cylinder parts are sealed with a special organic sealant and locking compound. Before attempting to disassemble these parts, remove any accessible seals from the area of the bonded parts. Wipe off any hydraulic oil, then heat the part(s) uniformly to break the bond. A temperature of 300-400° F (149-204° C) will destroy the bond. Avoid overheating, or the parts may become distorted or damaged. Apply sufficient torque for removal while the parts are still hot. The sealant often leaves a white, powdery residue on threads and other parts, which must be removed by brushing with a soft brass wire brush prior to reassembly.

9. Remove the piston head from the rod and carefully slide the head gland off the end of the rod.
10. Remove all seals, back-up rings and o-rings from the piston head and all seals, back-up rings and o-rings from the head gland.

Note: The head gland bearing will need to be inspected to determine if replacement is necessary.

DO NOT attempt to salvage cylinder seals, sealing rings or o-rings. ALWAYS use a new, complete seal kit when rebuilding hydraulic components. Consult the parts catalog for ordering information.

b. Cylinder Cleaning Instructions

1. Discard all seals, back-up rings and o-rings. Replace with new items from seal kit to ensure proper cylinder function.
2. Clean all metal parts with an approved cleaning solvent such as trichlorethylene. Carefully clean cavities, grooves, threads, etc.

Note: If a white powdery residue is present on threads or parts, it can be removed by using a soft brass wire brush. Wipe clean with Loctite® Cleaner prior to reassembly.

c. Cylinder Inspection

1. Inspect internal surfaces and all parts for wear, damage, etc. If the inner surface of the cylinder barrel does not display a smooth finish, or is scored or damaged in any way, replace the barrel.
2. Remove light scratches on the piston, head gland, rod or inner surface of the cylinder barrel with a 400-600 grit emery cloth. Use the emery cloth in a rotary motion to polish out and blend the scratch(es) into the surrounding surface.
3. Check the piston rod assembly for run-out. If the rod is bent, it must be replaced.

d. General Cylinder Assembly Instructions

1. Use the proper tools for specific installation tasks. Clean tools are required for installation.
2. Install new seals, back-up rings and o-rings on the piston and new seals, back-up rings, o-rings and bearing on the head gland.

Note: The extend/retract cylinder has a spacer that **MUST** be installed over the rod **AFTER** the head gland and **BEFORE** the piston head.

3. Fasten the rod eye in a soft-jawed vise, and place a padded support under and near the threaded end of the rod to prevent any damage to the rod.

Note: Protect the finish on the cylinder rod at all times. Damage to the surface of the rod can cause seal failure.

4. Lubricate and slide the head gland over the cylinder rod. Install the piston head on to the end of the cylinder rod. Loctite® 243™ and install the set screw in the piston head. Refer to Section 8.8.4, "Cylinder Torque Specifications - TL642" or Section 8.8.5, "Cylinder Torque Specifications - TL943" for torque specifications for the piston head and the set screw.

Note: Avoid using excess force when clamping the cylinder barrel in a vise. Apply only enough force to hold the cylinder barrel securely. Excessive force can damage the cylinder barrel.

5. Place the cylinder barrel in a soft-jawed vise or other acceptable holding device.

Note: When sliding the rod and piston assembly into the cylinder barrel, prevent the threaded end of the cylinder barrel from damaging the piston head. Keep the cylinder rod centered within the barrel to prevent binding.

6. Carefully insert the cylinder rod assembly into the cylinder barrel.



Hydraulic System

7. Screw the head gland into the cylinder barrel and tighten with a spanner wrench. Refer to Section 8.8.4, "Cylinder Torque Specifications - TL642" or Section 8.8.5, "Cylinder Torque Specifications - TL943" for torque specifications for the head gland.
8. If applicable, install new counter balance valve into block on the cylinder barrel.

e. General Cylinder Installation

1. Grease the bushings at the ends of the hydraulic cylinder. Using an appropriate sling, lift the cylinder into its mounting position.
2. Align cylinder bushing and install pin, lock bolt or retaining clip.
3. Connect the hydraulic hoses in relation to the labels or markings made during removal.
4. Before starting the machine, check fluid level of the hydraulic fluid reservoir and if necessary fill to full mark with hydraulic oil.
5. Properly connect the battery.
6. Start the machine and run at low idle for about one minute. Slowly activate hydraulic cylinder function in both directions allowing cylinder to fill with hydraulic oil.
7. Inspect for leaks and check level of hydraulic fluid in reservoir. Add hydraulic fluid if needed. Shut the engine OFF.
8. Wipe up any hydraulic fluid spillage in, on, near and around the machine, work area and tools.
9. Close and secure the engine cover.
10. Remove the Do Not Operate Tags from both the ignition key switch and the steering wheel.

8.8.2 Cylinder Pressure Checking

Attach a 5000 psi (345 bar) gauge to the test port on the P1 port on the priority valve to check the system pressure.

Note: *If a hydraulic cylinder pressure is greater than the main control valve pressure, increase the main control valve pressure by adjusting the main relief. Generally, one half turn clockwise will be adequate to check an individual circuit. Activate the circuit and if pressure is obtained turn the main relief counter clockwise one half turn. Re-check the main relief setting and adjust if necessary.*

8.8.3 Steering Cylinders

The steer cylinder is attached to each axle center housing. The steer cylinder assembly can be found in Section 5.3, "Axle Assemblies." The steer cylinder is covered in the appropriate manufacturer's axle literature.

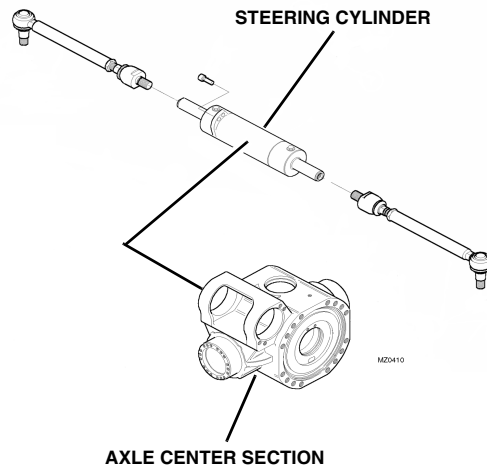



8.8.4 Cylinder Torque Specifications - TL642

a. Lift/Lower Cylinder

	Head	Nut	Bolt Plate	Valve	Valve Screw	Set Screw
S/N TBK00100 thru TBK00774	100 lb-ft (135 Nm)	2025-2075 lb-ft (2745-2813 Nm)		44 lb-ft (60 Nm)	10-12 lb-ft (14-16 Nm)	11 lb-ft (15 Nm)
S/N TBK00775 thru TBK00984	100 lb-ft (135 Nm)	1600-2000 lb-ft (2169-2712 Nm)		44 lb-ft (60 Nm)	10-12 lb-ft (14-16 Nm)	11 lb-ft (15 Nm)
S/N TBK00985 & After	100 lb-ft (135 Nm)		(See Note)	44 lb-ft (60 Nm)	10-12 lb-ft (14-16 Nm)	11 lb-ft (15 Nm)

Note: The capscrews for the bolt plate need to be torqued in sequence in an alternating pattern starting at 35 lb-ft to 75 lb-ft to the final 95 lb-ft. Check the final torque in a circular pattern a minimum of two times.

b. Extend/Retract Cylinder

	Head	Nut	Valve	Set Screw
S/N TBK00100 thru TBK00808	100 lb-ft (135 Nm)	600-650 lb-ft (813-881 Nm)	40-45 lb-ft (54-61 Nm)	11 lb-ft (15 Nm)
S/N TBK00809 & After	100 lb-ft (135 Nm)	1020-1250 lb-ft (1383-1695 Nm)	40-45 lb-ft (54-61 Nm)	11 lb-ft (15 Nm)

c. Tilt Cylinder

	Head	Nut	Valve	Set Screw
S/N TBK00100 thru TBK00763	200 lb-ft (271 Nm)	1250-1300 lb-ft (1694-1762 Nm)	40-45 lb-ft (54-61 Nm)	11 lb-ft (15 Nm)
S/N TBK00764 & After	200 lb-ft (271 Nm)	1125-1375 lb-ft (1525-1864 Nm)	40-45 lb-ft (54-61 Nm)	11 lb-ft (15 Nm)

d. Compensation Cylinder

Head	Nut	Set Screw
200 lb-ft (271 Nm)	1250-1300 lb-ft (1694-1762 Nm)	11 lb-ft (15 Nm)

e. Frame Level Cylinder

	Head	Nut	Set Screw
S/N TBK00100 thru TBK00753	100 lb-ft (165 Nm)	550-600 lb-ft (745-813 Nm)	11 lb-ft (15 Nm)
S/N TBK00754 & After	100 lb-ft (165 Nm)	800-1000 lb-ft (1085-1356 Nm)	11 lb-ft (15 Nm)

f. Outrigger Cylinder (if equipped)

Head	Nut	Set Screw
N/A	1300-1350 lb-ft (1763-1830 Nm)	11 lb-ft (15 Nm)



8.8.5 Cylinder Torque Specifications - TL943

a. Lift/Lower Cylinder

	Capscrew/Nut	Valve	Set Screw
Before S/N TBL00970	(See Note)	44 lb-ft (60 Nm)	11 lb-ft (15 Nm)
S/N TBL00970 & After	N/A	44 lb-ft (60 Nm)	11 lb-ft (15 Nm)

Note: The capscrews for the piston need to be torqued in sequence in an alternating pattern starting at 150 lb-ft to 300 lb-ft to the final 460 lb-ft. Check the final torque in a circular pattern a minimum of two times.

b. Extend/Retract Cylinder

	Head	Nut	Valve	Set Screw
Before S/N TBL01001	100 lb-ft (135 Nm)	1000 lb-ft (1355 Nm)	44 lb-ft (60 Nm)	11 lb-ft (15 Nm)
S/N TBL01001 & After	300-400 lb-ft (407-542 Nm)	745-825 lb-ft (1010-1118 Nm)	105-115 lb-ft (142-115 Nm)	11 lb-ft (15 Nm)

c. Tilt Cylinder

	Head	Nut	Valve	Valve Plug	Set Screw
Before S/N TBL00970	550-600 lb-ft (745-813 Nm)	2025-2075 lb-ft (2745-2813 Nm)	44 lb-ft (60 Nm)	10-15 lb-ft (14-20 Nm)	11 lb-ft (15 Nm)
S/N TBL00970 & After	N/A	2025-2075 lb-ft (2745-2813 Nm)	44 lb-ft (60 Nm)	10-15 lb-ft (14-20 Nm)	11 lb-ft (15 Nm)

d. Compensation Cylinder

	Head	Nut	Set Screw
Before S/N TBL00990	550-600 lb-ft (745-813 Nm)	2025-2075 lb-ft (2745-2813 Nm)	11 lb-ft (15 Nm)
S/N TBL00990 & After	550-600 lb-ft (745-813 Nm)	2025-2075 lb-ft (2745-2813 Nm)	11 lb-ft (15 Nm)

e. Frame Level Cylinder

	Head	Nut	Set Screw
Before S/N TBL00944	100 lb-ft (165 Nm)	400 lb-ft (542 Nm)	11 lb-ft (15 Nm)
S/N TBL00944 & After	N/A	720-800 lb-ft (976-1085 Nm)	11 lb-ft (15 Nm)



f. Outrigger Cylinder (if equipped)

Head	Nut	Set Screw
N/A	1300-1350 lb-ft (1763-1830 Nm)	11 lb-ft (15 Nm)



Hydraulic System

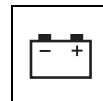

Section 9

Electrical System

Contents

PARAGRAPH	TITLE	PAGE
9.1	Electrical Component Terminology	9-3
9.1.1	General Overview	9-3
9.1.2	General Overview	9-4
9.2	Specifications	9-5
9.3	Safety Information	9-5
9.4	Fuses and Relays	9-5
9.4.1	Cab	9-5
9.4.2	Engine Compartment	9-5
9.4.3	Power Control Board	9-6
9.4.4	VEC Control Module	9-8
9.4.5	Universal Ground Control Module (UGM)	9-9
9.4.6	UGM Connections	9-10
9.5	Electrical System Schematics	9-11
9.5.1	Before S/N TBK01167 excluding TBK01162; Before S/N TBL01599 excluding TBL01551 & TBL01585	9-11
9.5.2	S/N TBK01167 & After including TBK01162; S/N TBL01599 & After including TBL01551 & TBL01585	9-18
9.6	Circuit Breakdowns	9-23
9.6.1	Constant Power Circuit from Battery	9-23
9.6.2	Start Circuit	9-24
9.6.3	Charging Circuit	9-25
9.7	Engine Start Circuit	9-26
9.7.1	Starter	9-26
9.8	Charging Circuit	9-27
9.8.1	Alternator	9-27
9.9	Window Wiper/Washer Windshield Wiper Motor	9-28
9.9.1	Windshield/Rear Window Washer Reservoir	9-29
9.10	Cab Heater/AC and Fan	9-29
9.10.1	Cab Heater/AC Controls	9-29
9.11	Switches, Solenoids and Senders	9-30
9.11.1	Priority Valve	9-30
9.11.2	Transmission Solenoid Valves	9-31
9.11.3	Transmission Temperature Switch	9-32
9.11.4	Engine Coolant Temperature Sensor	9-32
9.11.5	Engine Oil Pressure Sender/Sensor	9-33
9.11.6	Fuel Level Sender	9-33
9.12	Gauges and Display Monitor	9-34
9.12.1	Analog Gauges	9-34
9.12.2	3-N-1 Digital Gauge	9-35



Electrical System

9.13	Dash Switches	9-36
9.13.1	Ignition Key Switch	9-36
9.13.2	Dash Switches	9-36
9.13.3	Rheostat Switch (if equipped)	9-37
9.14	Hand Held Analyzer (S/N TBL01599 & After including TBL01551 & TBL01585)	9-38
9.14.1	Analyzer Usage	9-38
9.14.2	Analyzer Software Version A	9-39
9.14.3	Personality Settings	9-40
9.14.4	Tilt/Auxiliary Calibration Menu	9-41
9.14.5	Joystick Fault Codes	9-42
9.15	Engine Diagnostic and Event Codes (S/N TBK01167 & After including TBK01162; S/N TBL01599 & After including TBL01551 & TBL01585)	9-47

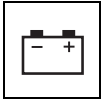

9.1 ELECTRICAL COMPONENT TERMINOLOGY

To understand the safety, operation, and service information presented in this section, it is necessary that the operator/mechanic be familiar with the name and location of the electrical components of the machine. The following illustration identifies the components that are referred to throughout this section.

9.1.1 General Overview

TL642 - Before S/N TBK01167 excluding TBK01162

TL943 - Before S/N TBL01599 excluding TBL01551 & TBL01585

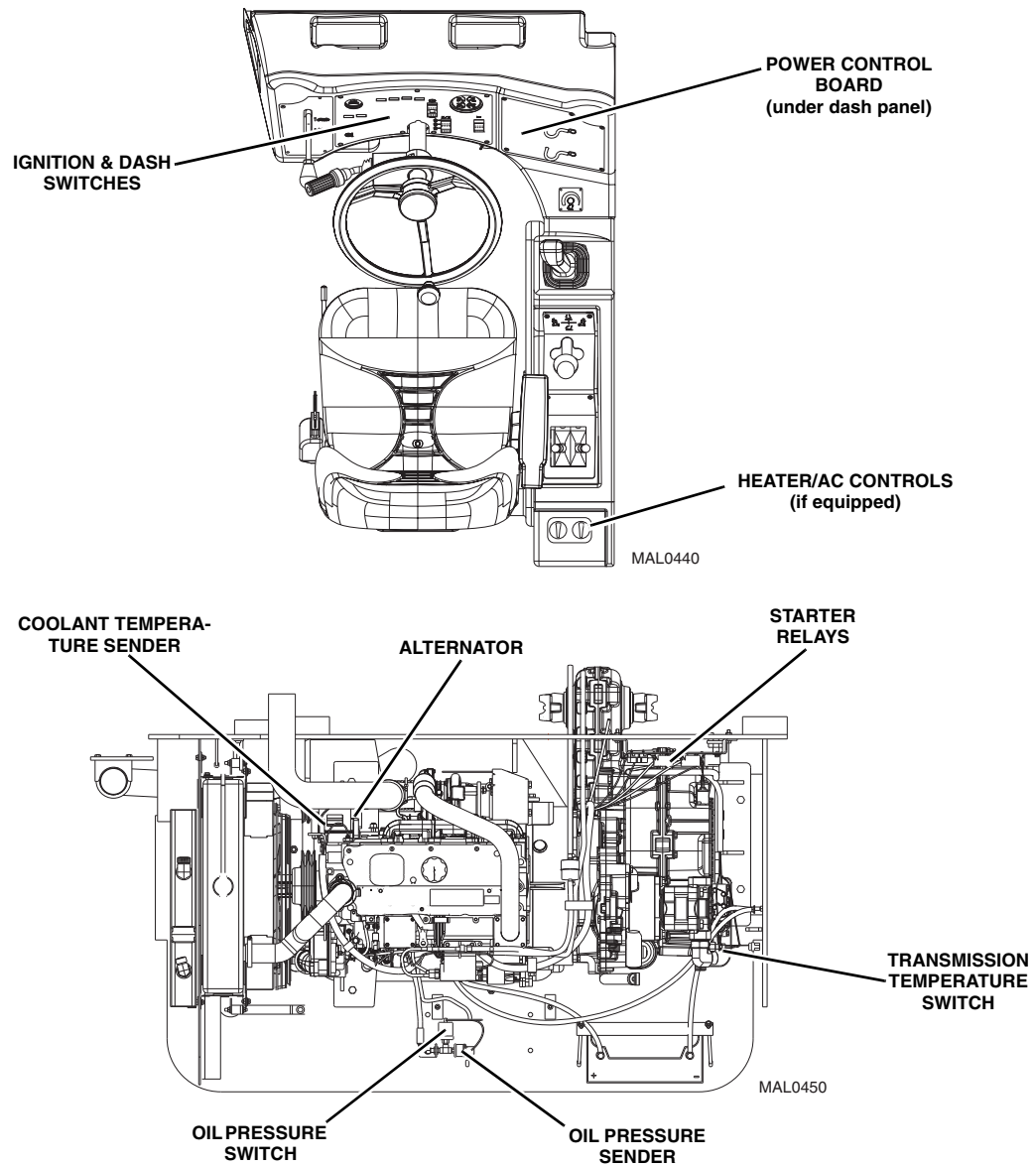



Electrical System

9.1.2 General Overview

TL642 - S/N TBK01167 & After including TBK01162

TL943 - S/N TBL01599 & After including TBL01551 & TBL01585

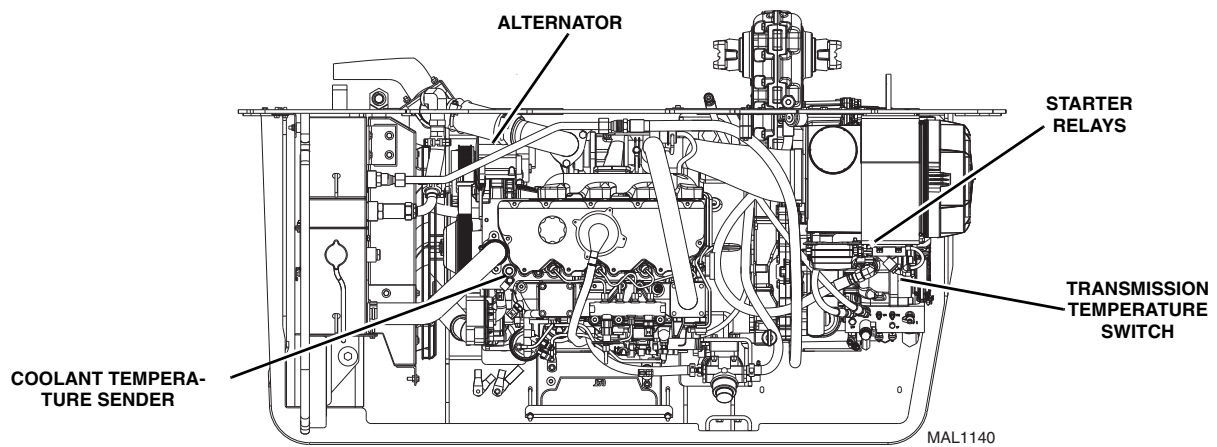
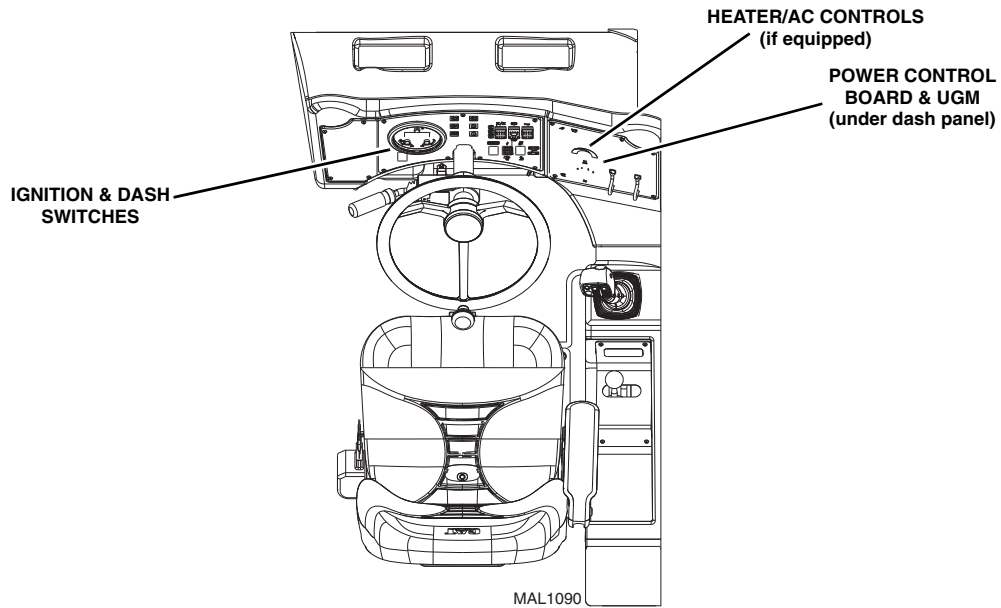

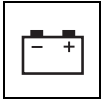

9.2 SPECIFICATIONS

Electrical system specifications are listed in Section 2, "General Information and Specifications."

9.3 SAFETY INFORMATION

WARNING

DO NOT service the machine without following all safety precautions as outlined in Section 1, "Safety Practices," of this manual.

9.4 FUSES AND RELAYS

9.4.1 Cab

TL642 - Before S/N TBK01167 excluding TBK01162

TL943 - Before S/N TBL01599 excluding TBL01551 & TBL01585

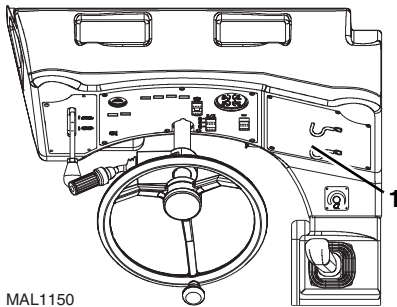

MAL1150

For access to the fuse and relay panel, remove the screws securing the load chart panel (1) to the dash. The fuses and sealed 12-volt relays are mounted under the panel.

9.4.2 Engine Compartment

TL642 - Before S/N TBK01167 excluding TBK01162

TL943 - Before S/N TBL01599 excluding TBL01551 & TBL01585

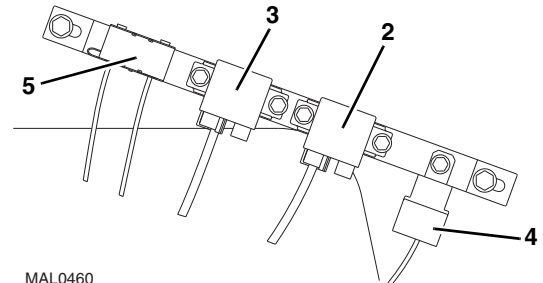

MAL0460

The starter relay (2), glow plug relay (3), fuel pump relay (4), 50 amp fuse (5) are located on the frame directly above the engine.

TL642 - S/N TBK01167 & After including TBK01162

TL943 - S/N TBL01599 & After including TBL01551 & TBL01585

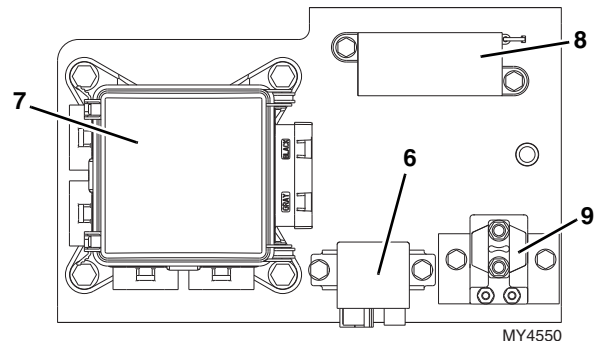

MY4550

The starter relay (6) and VEC control module (7) 100 amp relay(8), 60 amp fuse (9) are located on the power distribution unit bracket in the engine compartment.



Electrical System

9.4.3 Power Control Board

TL642 - Before S/N TBK01167 excluding TBK01162

TL943 - Before S/N TBL01599 excluding TBL01551 & TBL01585

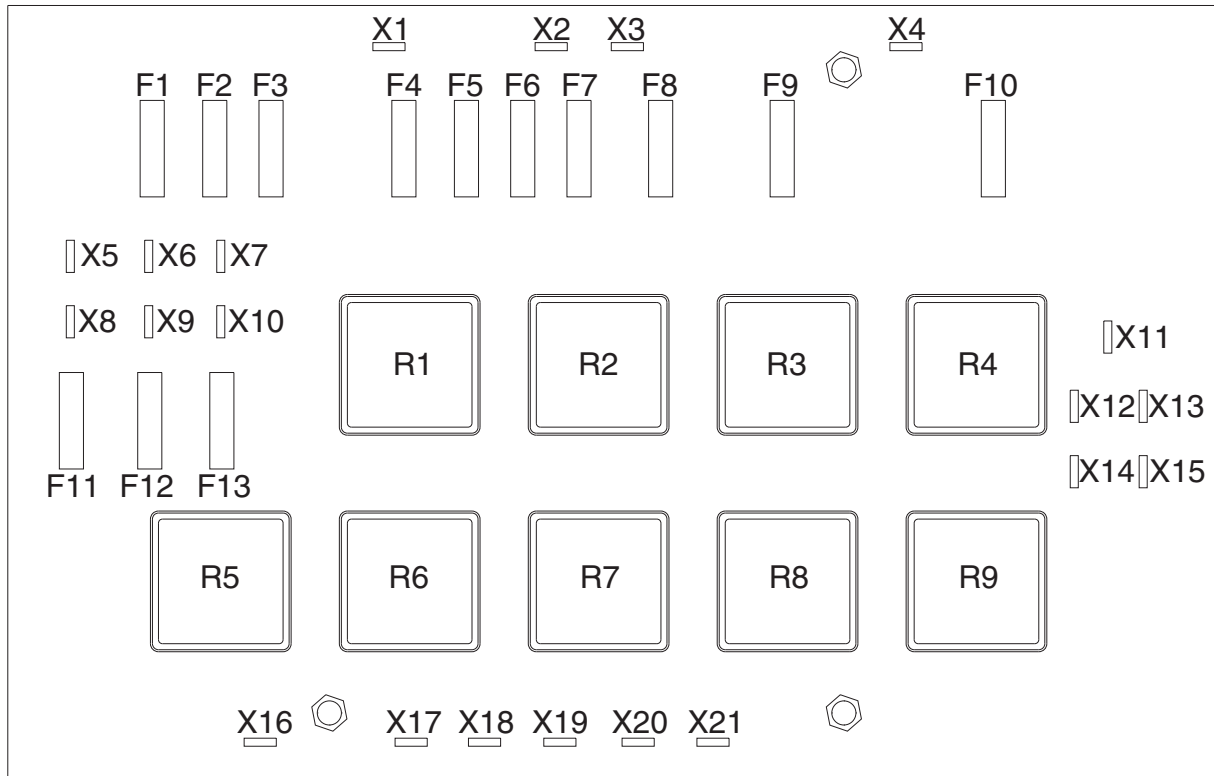

MY0391

FUSE/BREAKER LEGEND/CONNECTOR LEGEND		
No.	Function	Amp Rating
F1	OPTIONAL POWER	30
F2	HORN	10
F3	KEY	15
F4	SPARE BATTERY	25
F5	STEER	10
F6	GAUGES	10
F7	RELAYS	10
F8	LIGHTS	25
F9	W/W	25
F10	FAN/HEATER	25
F11	OPTION3	15
F12	OPTION2	15
F13	OPTION1	10
R1	ACC	
R2	LIGHTS	
R3	W/W	

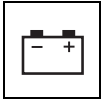

FUSE/BREAKER LEGEND/CONNECTOR LEGEND		
No.	FUNCTION	Amp Rating
R4	FAN/HEATER	
R5	OPT	
R6	AUX ELEC2	
R7	AUX ELEC1	
R8	WARN LT CK	
R9	REV ALARM	
X1	SPARE BAT	
X2	SL SWA	
X3	WL SWA	
X4	W/W SW	
X5	GND 3	
X6	GND 2	
X7	GND 1	
X8	OPT 3	
X9	OPT 2	
X10	OPT 1	
X11	FAN SW	
X12	HEATER SW	
X13	WL 2	
X14	SL SWB	
X15	WL SWB	
X16	SPARE COIL	
X17	GND 85	
X18	SW1-87A	
X19	SW2-86	
X20	SW2-87A	
X21	SW1-86	



Electrical System

9.4.4 VEC Control Module

TL642 - S/N TBK01167 & After including TBK01162

TL943 - S/N TBL01599 & After including TBL01551 & TBL01585

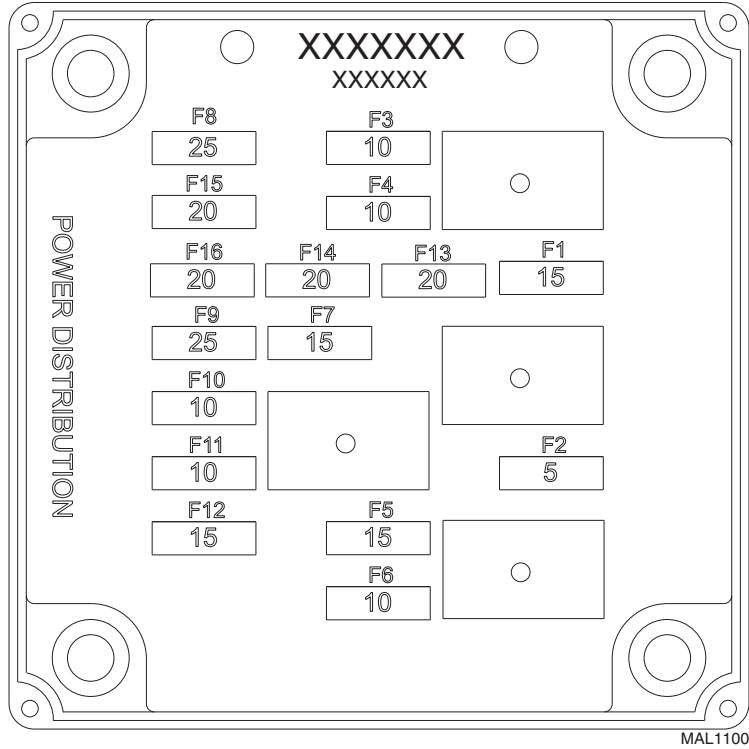

FUSE/BREAKER LEGEND		
No.	Function	Amp Rating
F1	TRANS/PARK BRK PWR	15
F2	ALTERNATOR EXCITE	5
F3	ENGINE ECU IGNITION PWR	10
F4	GAGE (INST PANEL) PWR	10
F5	SPARE ACCESSORY PWR	15
F6	AUX ELECTRIC PWR	10
F7	HORN PWR	15
F8	SPARE BATTERY PWR	25
F9	ENGINE ECU BATTERY PWR	25
F10	STEER/FRAME LEVEL PWR	10
F11	REAR AXLE STABILITY/TILT PWR	10
F12	KEY BATTERY PWR	15
F13	OPTION PWR 3	20
F14	OPTION PWR 4	20
F15	OPTION PWR 1	20
F16	OPTION PWR 2	20

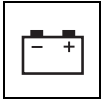

9.4.5 Universal Ground Control Module (UGM)

TL943 - S/N TBL01599 & After including TBL01551 & TBL01585

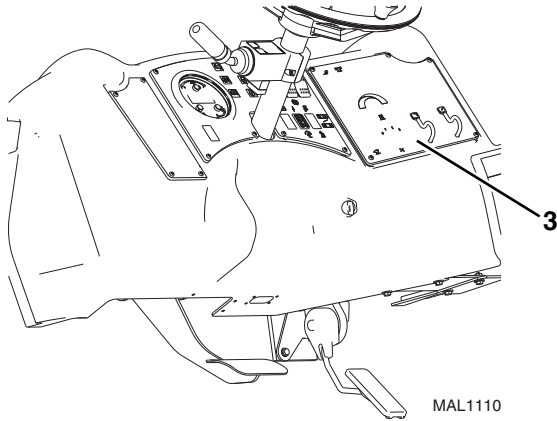

The UGM is located behind the right hand side panel (3) of the dash.

a. UGM Removal

1. Park the machine on a firm, level surface, level the machine, fully retract the boom, lower the boom, place the transmission control lever in (N) NEUTRAL, engage the park brake and shut the engine OFF.
2. Place a Do Not Operate Tag on both the ignition key switch and the steering wheel, stating that the machine should not be operated.
3. Open the engine cover. Allow the system fluids to cool.
4. Properly disconnect the battery.
5. Remove the hardware securing the right hand side panel to the dash.
6. Disconnect the electrical harnesses attached to the UGM.
7. Remove the bolts securing the UGM to the cab and remove the UGM.

b. Disassembly

DO NOT disassemble the UGM. The module is not serviceable. Replace the module if found to be defective.

c. Inspection and Replacement

Inspect the module terminals for continuity. Replace the module if continuity is not found.

d. UGM Installation

1. Attach the UGM to the cab with the previously removed hardware
2. Reconnect the electrical harnesses to the UGM.
3. Install the right hand side panel to the dash with the previously removed hardware.
4. Properly connect the battery.
5. Close and secure engine cover.
6. Remove the Do Not Operate Tags from both the ignition key switch and the steering wheel.



Electrical System

9.4.6 UGM Connections

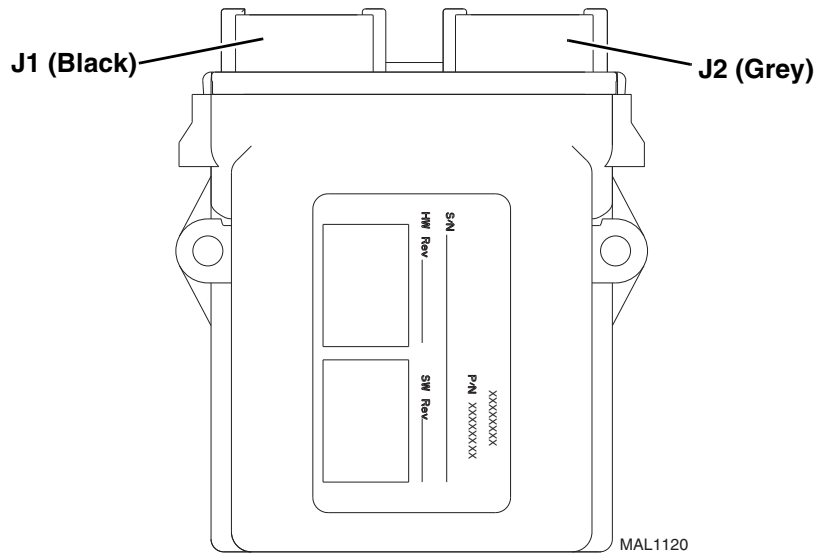

Connector	Pin	Tag Name	Description	Type	
J1 (Black)	1	KEY IGN	Ignition	Power	Input
	2	ACC MOD GND	Accessory Module Ground	Power	Input
	3	TRIG	Joystick Trigger For De-Clutch	Digital	Input
	4	DCLUTCH IN	Transmission De_Clutch Input	Digital	Input
	5	D12	Spare Digital Input	Digital	Input
	6	ROLLER SEL	Roller/Joystick Select	Digital	Input
	7	TILT UP	Tilt Up Valve	Digital	Output
	8	TILT DOWN	Tilt Down Valve	Digital	Output
	9	AUX A	Auxiliary Hydraulic Valve A	Digital	Output
	10	AUX B	Auxiliary Hydraulic Valve B	Digital	Output
	11	DCLUTCH	Transmission De-Clutch Output	Digital	Output
	12	GND FAULT	Ground Rely Fault Signal	Digital	Output
J2 (Grey)	1	5 EXC TILT	+5V Analog Excitation Voltage	Power	Output
	2	TILT SIG A	Fork Tilt Signal A	Analog	Input
	3	TILT GRD	Analog Ground	Power	Output
	4	5 EXC AUX	+5V Analog Excitation Voltage	Power	Output
	5	AUX SIG A	Auxiliary Hydraulic Signal A	Analog	Input
	6	AUX GND	Analog Ground	Power	Output
	7	TILT SIG B	Fork Tilt Signal B	Analog	Input
	8	AUX SIG B	Auxiliary Hydraulic Signal B	Analog	Input
	9	CAN L/904	CANBUS High	Serial	I/O
	10	CAN L/905	CANBUS Low	Serial	I/O
	11	TX	RS-232 Transmit	Serial	Output
	12	RX	RS-232 Receive	Serial	Input

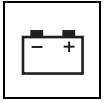

9.5 ELECTRICAL SYSTEM SCHEMATICS

9.5.1 Before S/N TBK01167 excluding TBK01162; Before S/N TBL01599 excluding TBL01551 & TBL01585

a. Cab Schematic

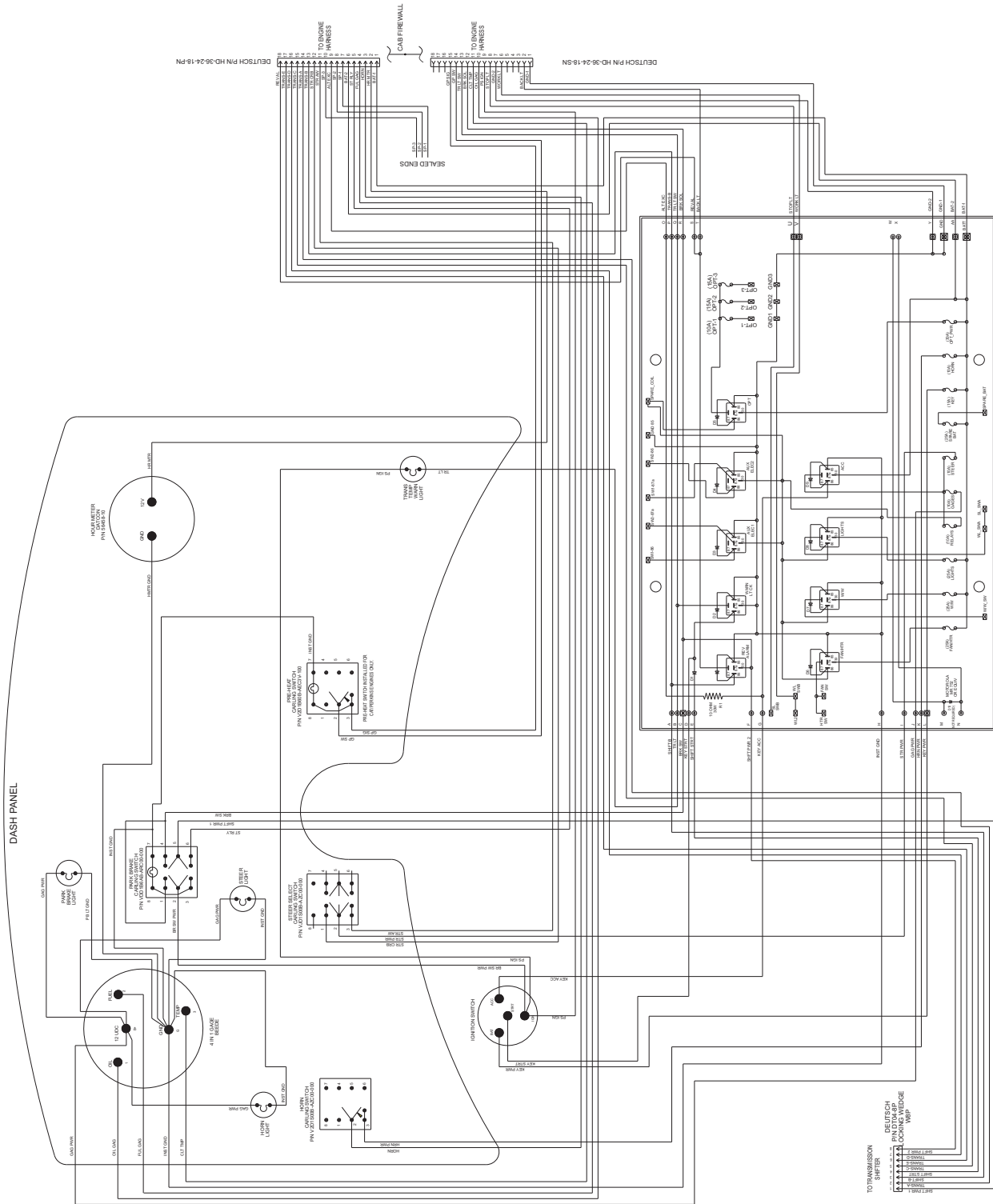

MY1370



Electrical System

b. Engine Schematic

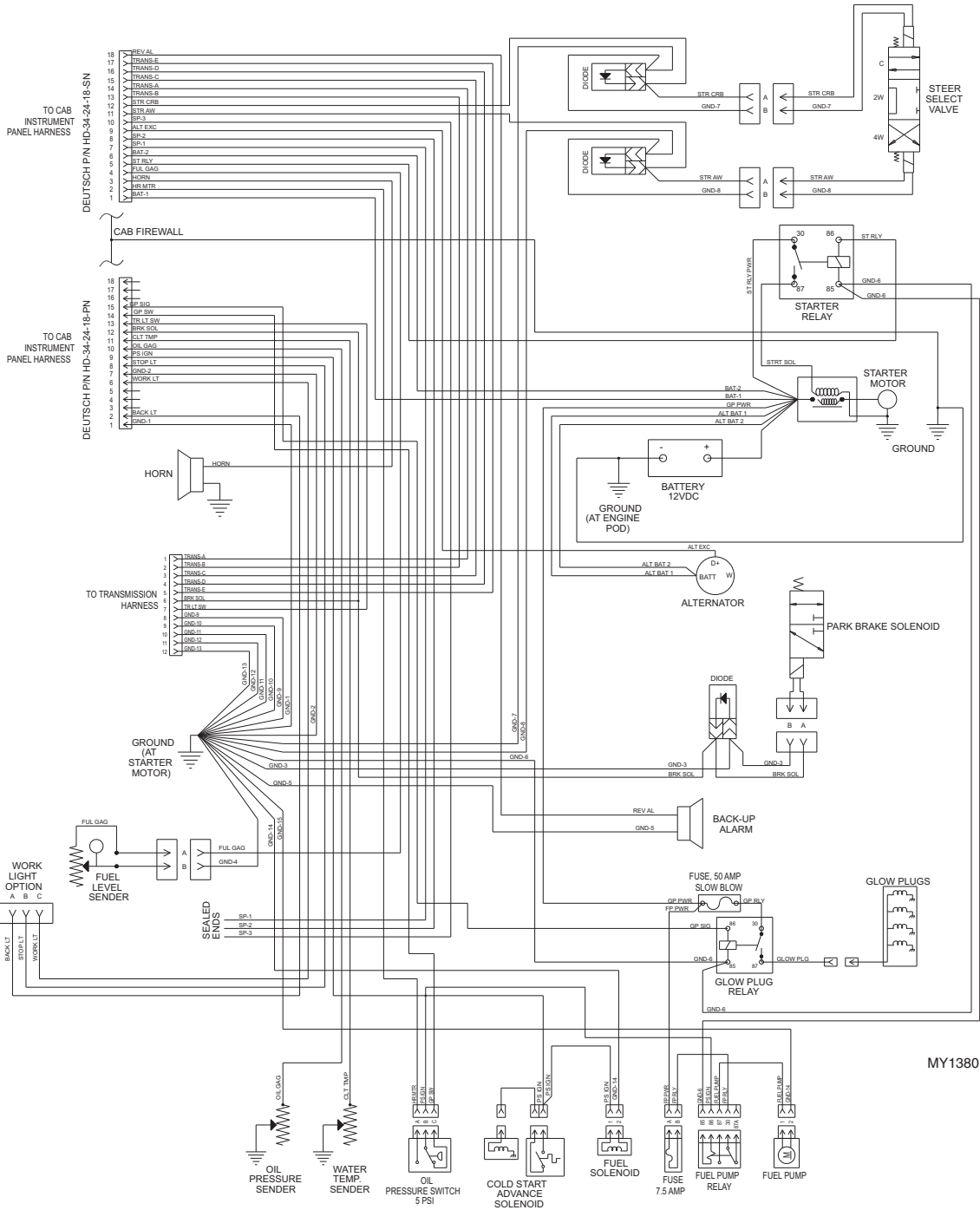

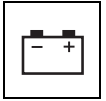

c. Transmission Schematic

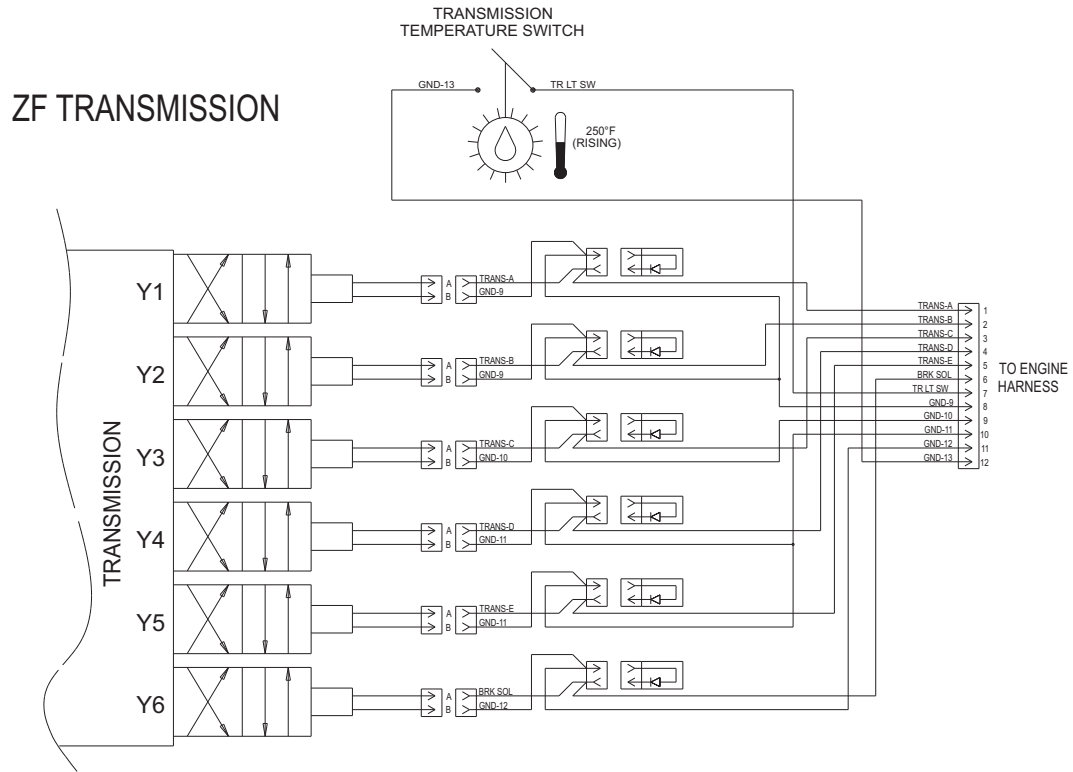

ZF/HOBBS SHIFTER

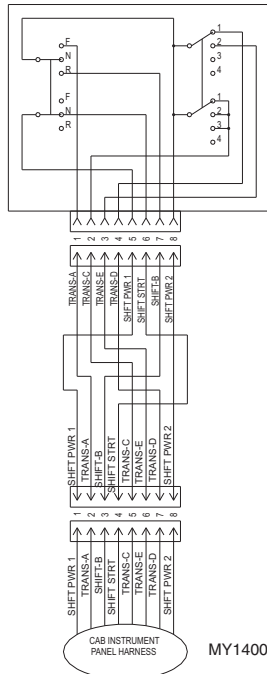



Electrical System

d. Auxiliary Schematic

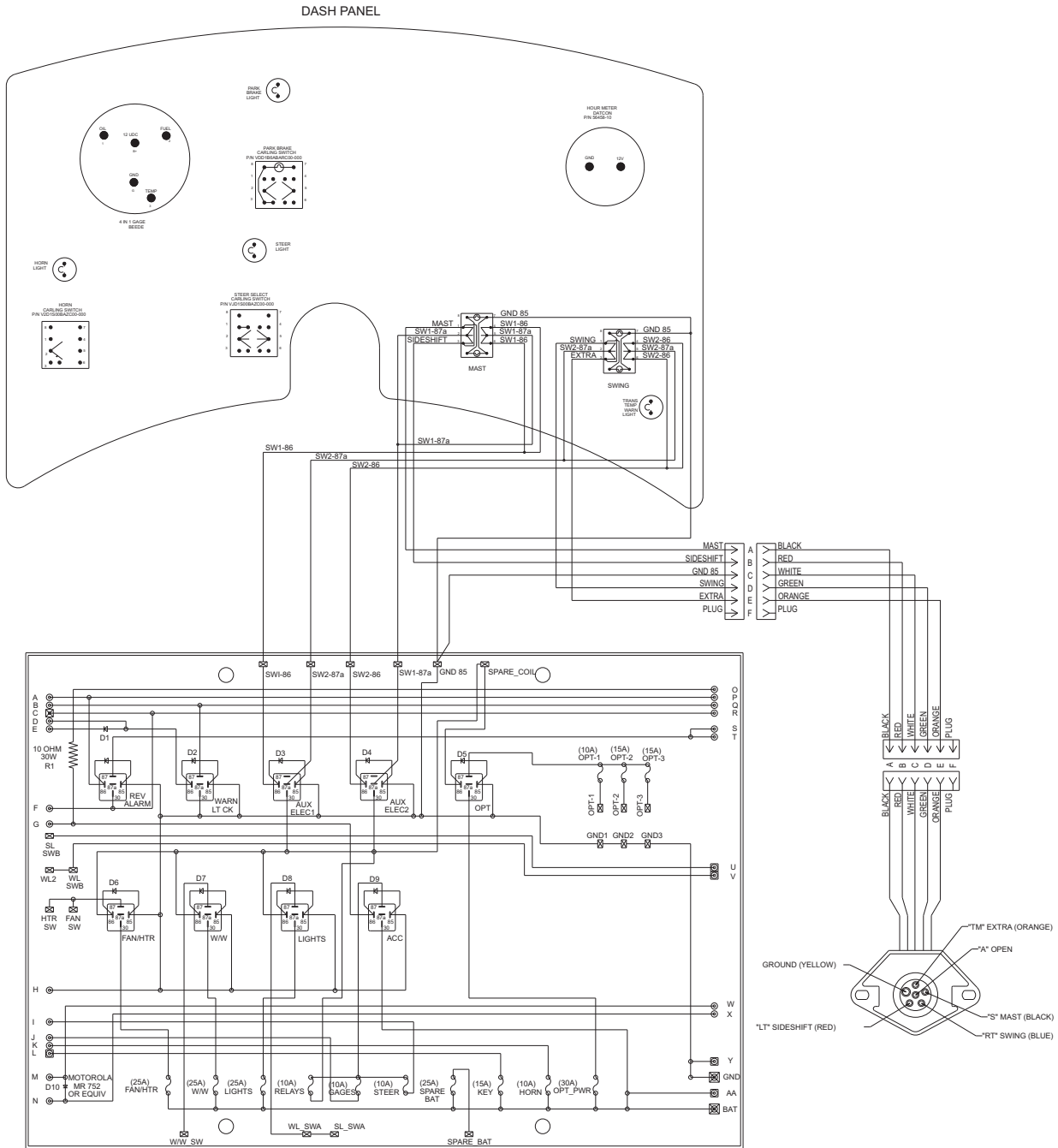

AUX ELECTRIC OPTION

MY1420

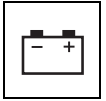

e. Quick Coupler Schematic

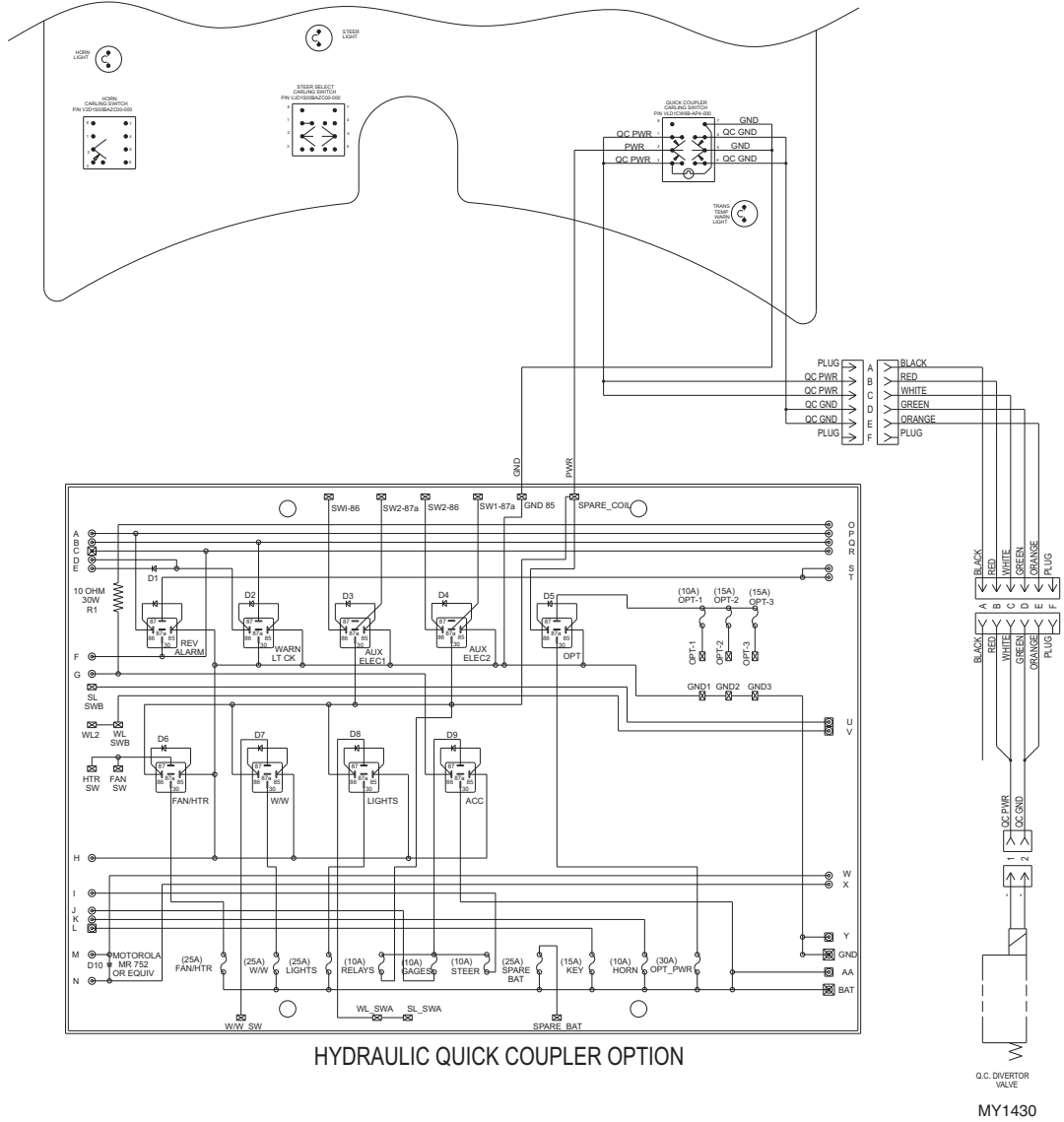



Electrical System

f. Work Light Schematic

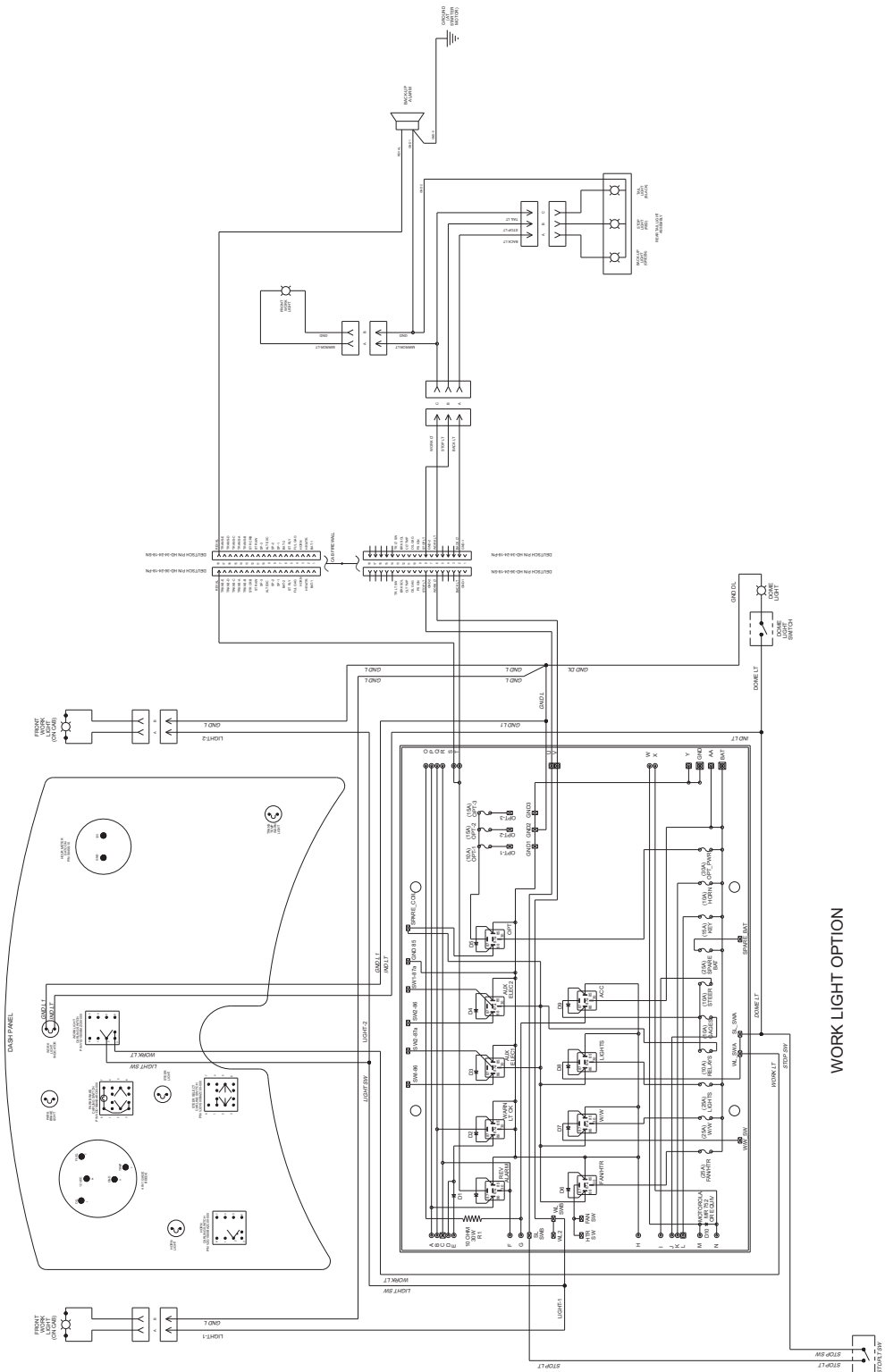

MY1440

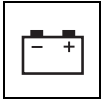

g. Bacon Light Schematic

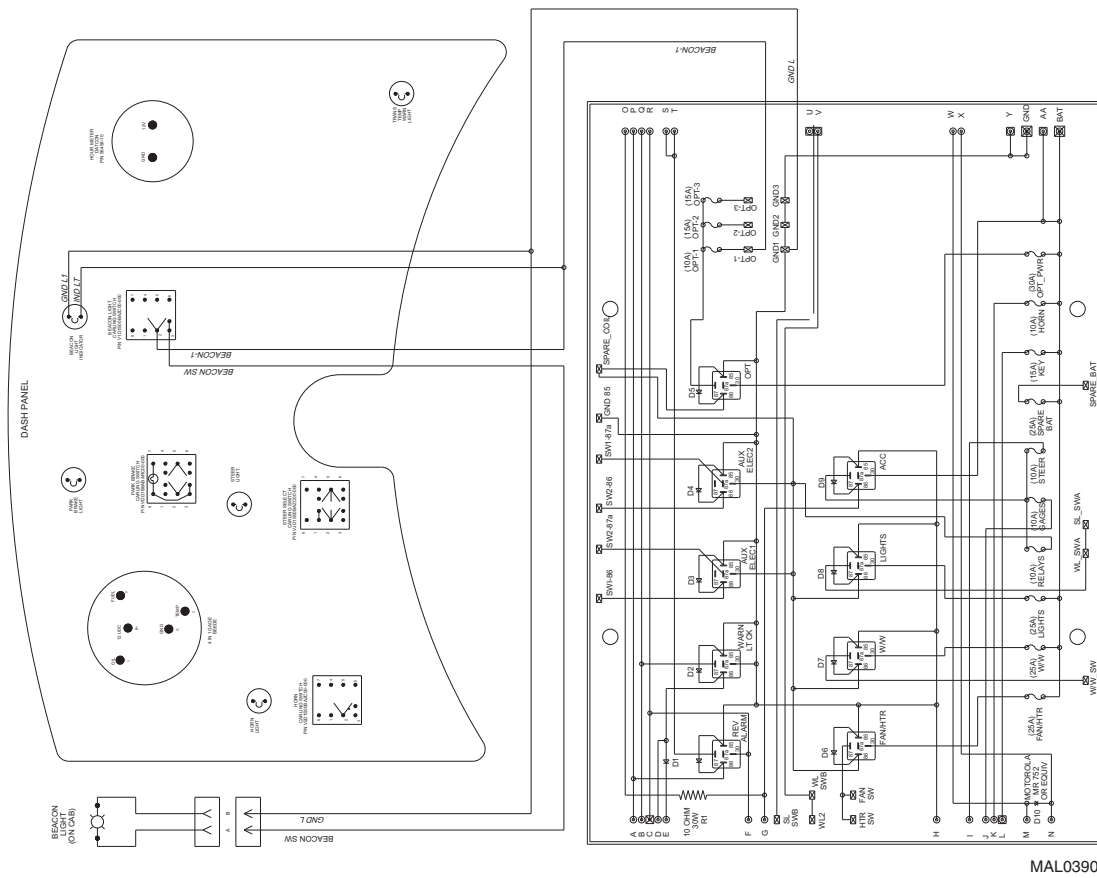

BEACON LIGHT OPTION



Electrical System

c. Engine Schematic

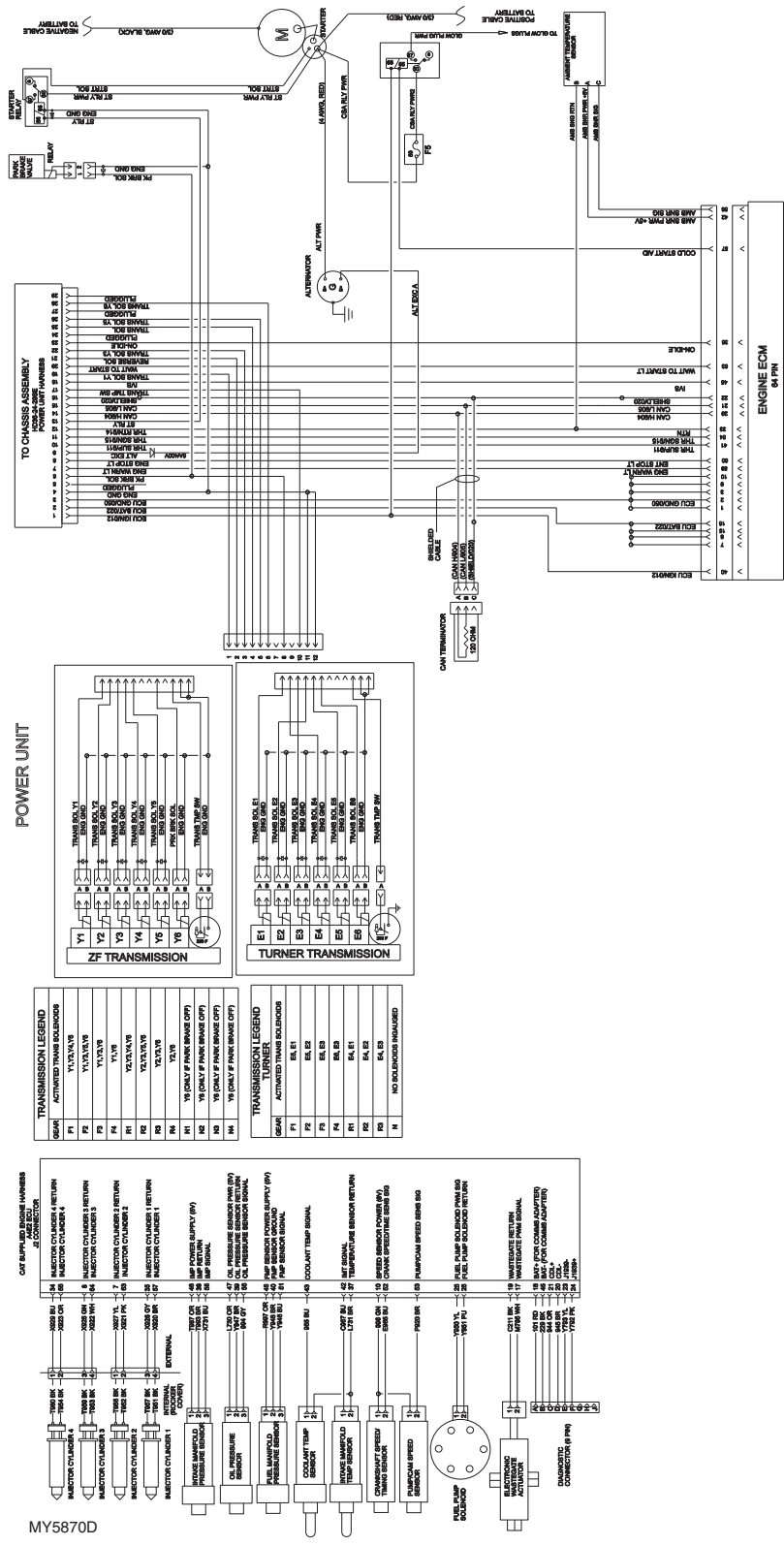

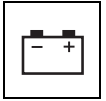

d. Auxiliary Schematic (TL943 ONLY)

ACCESSORY MODULE OPTION

CONNECTOR PIN	TAG/NAME	DESCRIPTION	TYPE
1	KEY IGN	IGNITION	POWER INPUT
2	ACC MOD GND	ACCESSORY MODULE GROUND	POWER INPUT
3	TRIG	JOYSTICK TRIGGER FOR DE-CLUTCH	DIGITAL INPUT
4	DC5V IN	5V DIGITAL INPUT	DIGITAL INPUT
5	DC	SPARE DIGITAL INPUT	DIGITAL INPUT
6	ROLLER SEL	ROLLER/JOYSTICK SELECT	DIGITAL INPUT
7	TLT UP	TLT UP VALVE	DIGITAL OUTPUT
8	TLT DN	TLT DOWN VALVE	DIGITAL OUTPUT
9	AUX A	AUX HYD VALVE A	DIGITAL OUTPUT
10	AUX B	AUX HYD VALVE B	DIGITAL OUTPUT
11	DC/CLUTCH	TRANSMISSION DE-CLUTCH OUTPUT	DIGITAL OUTPUT
12	GND FAULT	GND RLY FAULT SIG	DIGITAL OUTPUT

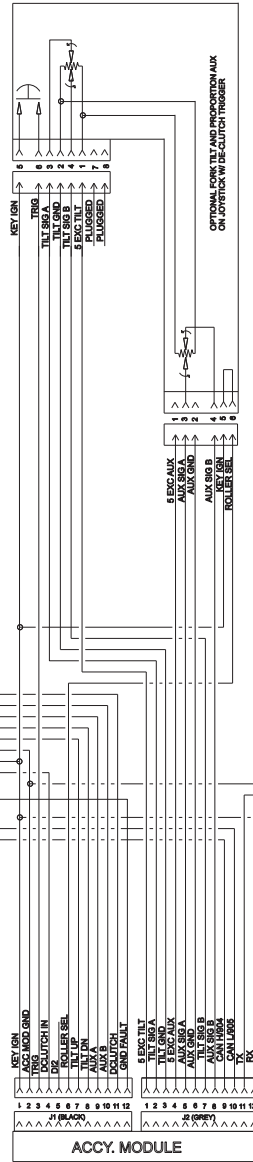
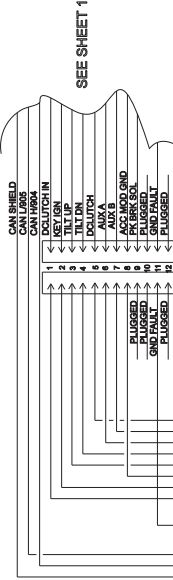
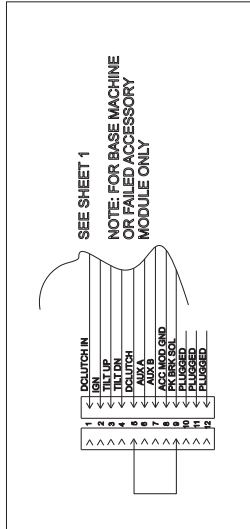

MY5850D

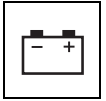

9.6 CIRCUIT BREAKDOWNS

9.6.1 Constant Power Circuit from Battery

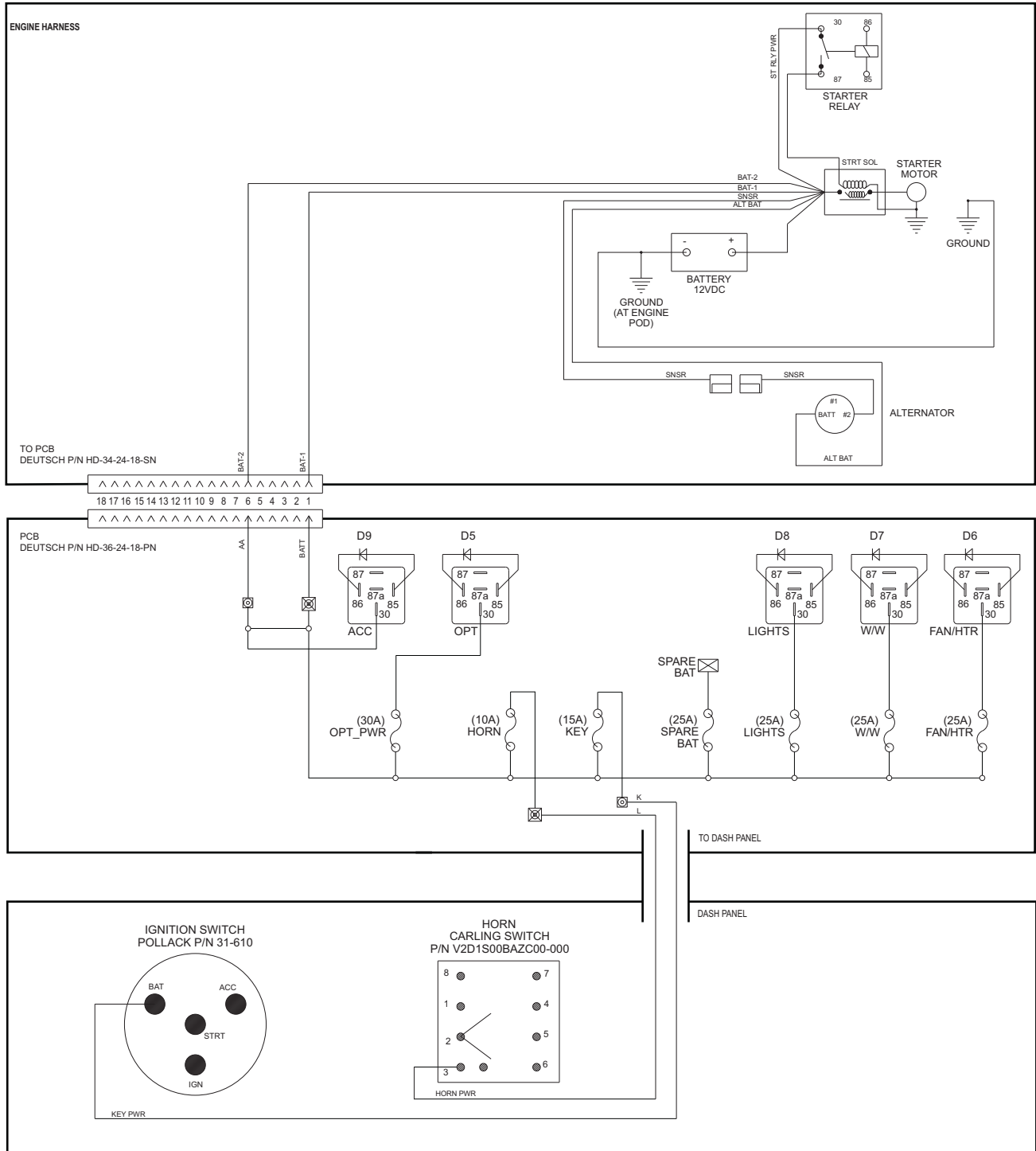

MY0810



Electrical System

9.6.2 Start Circuit

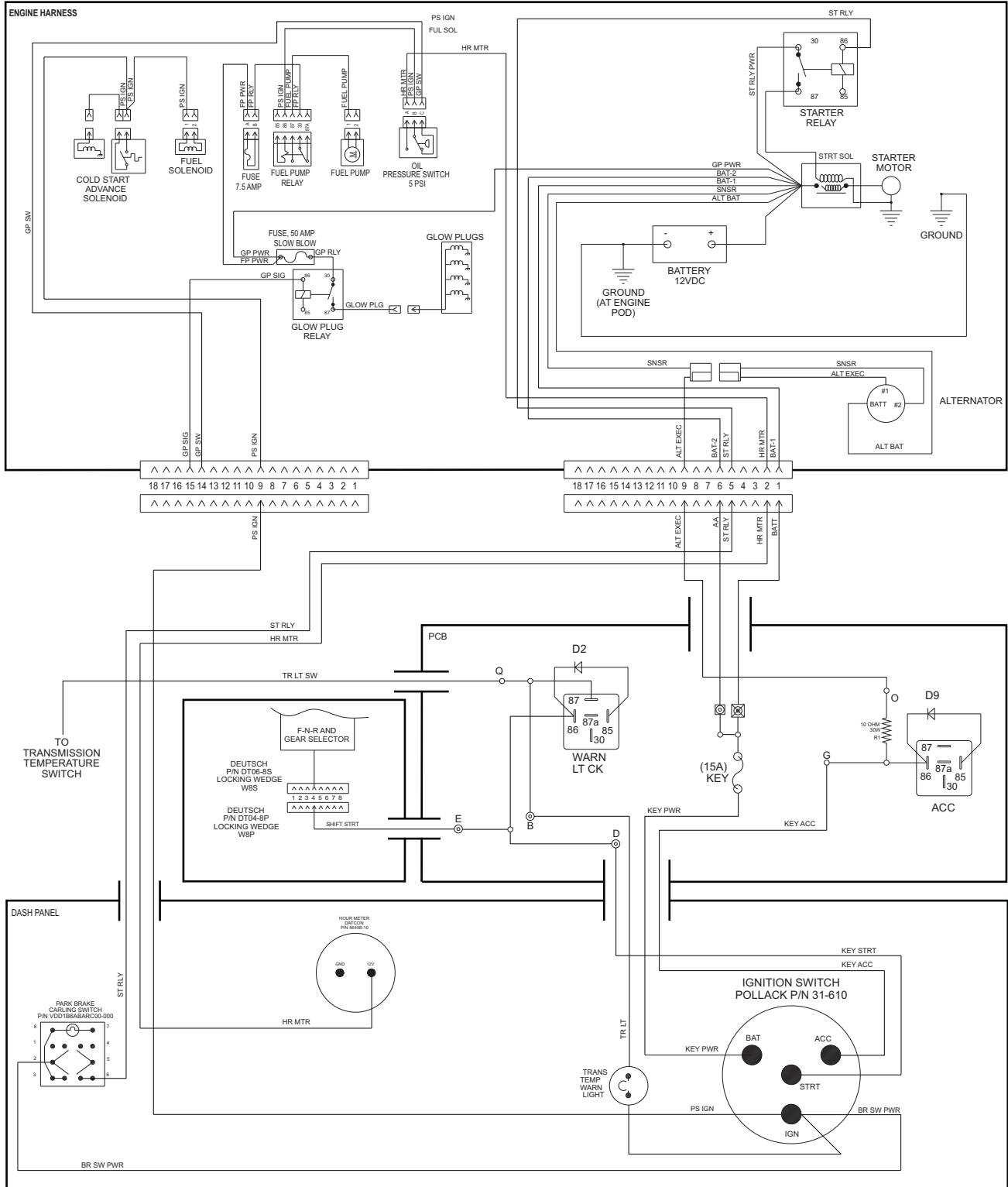

MY1630

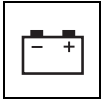

9.6.3 Charging Circuit

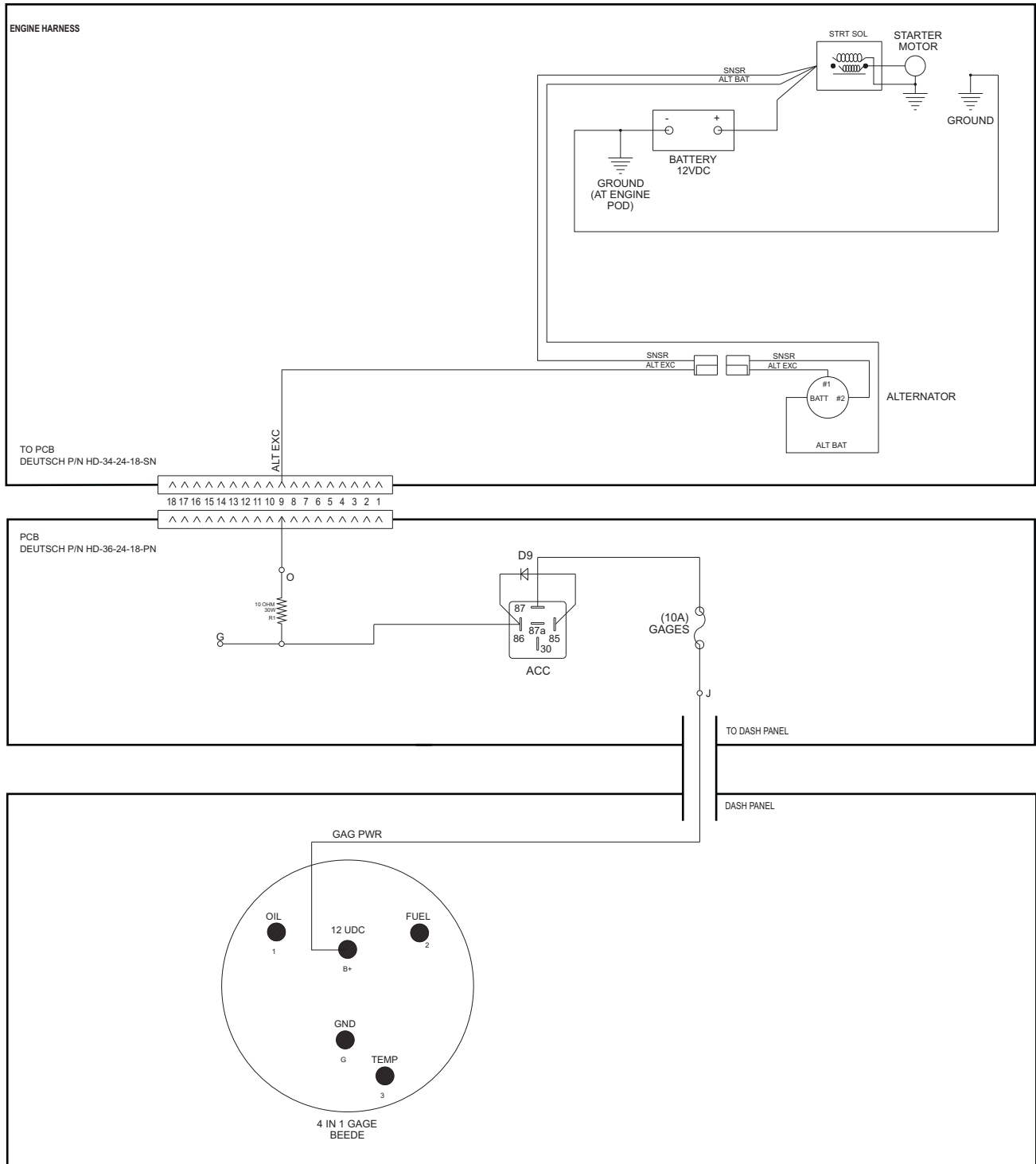

MY0800



9.7 ENGINE START CIRCUIT

9.7.1 Starter

a. Testing the Starter on the Engine

If the starter does not engage when the ignition key switch is turned, check the following:

1. The main fuse may be blown, requiring replacement. Check for the cause of the blown fuse.
2. There may be a defect in the ignition key switch, ignition wiring or starter solenoid.
3. Check battery condition. Clean the battery posts and the connectors at each end of the battery cables.
4. Check for broken wiring and damaged insulation on the wiring. Replace all broken or damaged wiring.
5. Check all connections at the starter solenoid, key switch and wiring harness plugs. Clean and tighten all connections.
6. If the starter still does not operate after these checks have been performed, check the starting circuit.

b. Starter Circuit Checks

1. Check wires and connections for looseness, corrosion, damage, etc.
2. If a “whirring” noise is heard but the engine does not turn over, the starter is spinning but not engaging the flywheel. The starter drive or solenoid that pushes the drive forward to engage the flywheel may be defective. Missing or damaged teeth on the flywheel can also prevent the starter from cranking the engine.
3. If the starter only “clicks” it may indicate that the battery is discharged, or that there is a loose or corroded battery cable connection. Check the battery state of charge and battery condition first, then check the cables and cable connections.
4. For additional information on the starting circuit, refer to Section 9.5, “Electrical System Schematics.”

c. Starter Removal

Remove the starter only if it fails. To remove the starter:

1. Park the machine on a firm, level surface, level the machine, fully retract the boom, lower the boom, place the travel select lever in the (N) NEUTRAL position, engage the parking brake and turn the engine OFF.

2. Place a Do Not Operate Tag on both the ignition key switch and the steering wheel, stating that the machine should not be operated.
3. Open the engine cover.
4. Properly disconnect the battery.

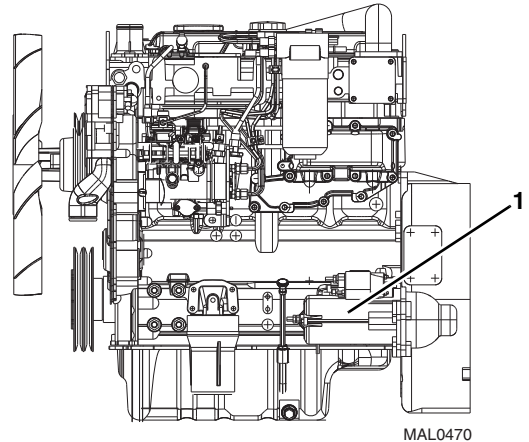

MAL0470

5. Remove the wires from the solenoid stud. Remove the positive (+) battery cable from the starter (1). Label and disconnect the wire from the starter solenoid housing stud. Record how the wires are installed to ensure correct installation later.
6. Loosen, but **DO NOT** remove, the three fasteners securing the starter to the flywheel housing. Support the starter securely, as it is relatively heavy and will fall if not supported.
7. Support the starter and remove the fasteners securing the starter to the engine. Remove the negative (-) ground cable from its starter mounting bolt.
8. Remove the starter from the machine.

d. Starter Installation

1. Position the starter in its mounting opening on the flywheel housing. Position the ground cable over the correct starter mounting bolt. Secure the starter with the three fasteners.
2. Connect the positive (+) battery cable to the upper solenoid stud. Install the wires to the upper solenoid stud, and secure with lock washer and nut.
3. Connect the wire to the solenoid mounting stud.
4. Properly connect the battery.
5. Close and secure the engine cover.
6. Remove the Do Not Operate Tags from both the ignition key switch and the steering wheel.

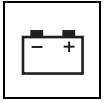

9.8 CHARGING CIRCUIT

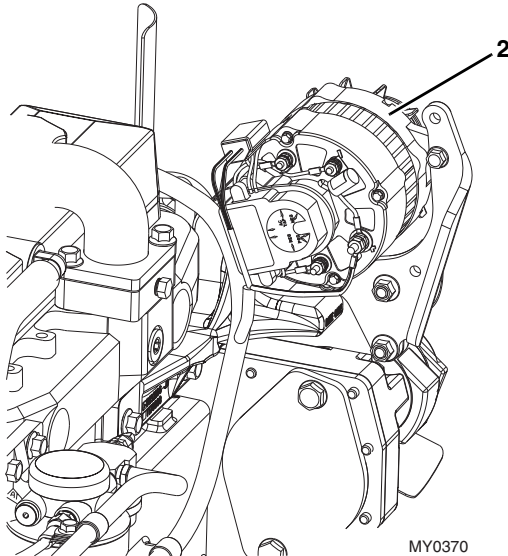

Before using a battery charger, an attempt can be made to recharge the battery by jump-starting the machine (Refer to the appropriate Operation & Maintenance Manual). Allow the engine to run, which will enable the alternator (2) to charge the battery.

If the engine alternator charging warning indicator illuminates, perform the following checks:

1. Check all battery cable connections at the battery, and verify that they are clean and tight.
2. Check the external alternator wiring and connections, and verify that they are in good condition.
3. Check the fan belt condition and tension.
4. Run the engine and check the alternator for noise. A loose drive pulley, loose mounting hardware, worn or dirty internal alternator bearings, a defective stator or defective diodes can cause noise. Replace a worn or defective alternator.

9.8.1 Alternator

a. Alternator Removal

1. Park the machine on a firm, level surface, level the machine, fully retract the boom, lower the boom, place the travel select lever in the (N) NEUTRAL position, engage the parking brake and turn the engine OFF.
2. Open the engine cover. Allow the system fluids to cool.
3. Properly disconnect the battery.

4. Install a drive ratchet into the square hole in the serpentine belt tensioner bracket.
5. While lifting the automatic belt tensioner away from the belt, remove the fan serpentine belt.

Note: Record how the alternator is installed to ensure correct installation later.

6. Label and disconnect the wire leads attached to the alternator.
7. Remove the lower mounting capscrew securing the alternator to the lower mounting hole on the engine.
8. While supporting the alternator with one hand, remove the upper (longer) mounting hardware from the upper alternator mount. Remove the alternator from the machine.

b. Alternator Installation

1. Position the alternator and align with the upper alternator mount on the engine bracket. Insert the upper (longer) mounting hardware through the alternator mount. Thread the longer capscrew into the alternator front mount. **DO NOT** tighten completely at this time.
2. Align the lower alternator mount hole with the lower mounting bracket on the engine, and insert the lower mounting capscrew. Tighten the lower capscrew and upper capscrew securely.
3. Place a drive ratchet into the square hole on the serpentine belt tensioner bracket. Apply pressure against the tensioner bracket and route the serpentine belt onto the alternator and engine pulleys. Release and check the tensioner pulley to verify that it is pivoting freely in order to provide the proper tension on the belt. Check for proper belt alignment. (Refer to the appropriate Operation & Maintenance Manual.)
4. Connect the previously labeled wire leads to the alternator.
5. Properly connect the battery.
6. Close and secure the engine cover.
7. Remove the Do Not Operate Tags from both the ignition key switch and the steering wheel.



9.9 WINDOW WIPER/WASHER WINDSHIELD WIPER MOTOR

a. Removal

Note: It may be necessary to remove several hydraulic hoses from behind the dash in order to remove and install the wiper motor housing. (Refer to Section 4.3.1, “Steering Column and Orbitrol Valve.”)

1. Park the machine on a firm, level surface, level the machine, fully retract the boom, lower the boom, place the transmission control lever in (N) NEUTRAL, engage the park brake and shut the engine OFF.
2. Place a Do Not Operate Tag on both the ignition key switch and the steering wheel, stating that the machine should not be operated.
3. Open the engine cover. Allow the system fluids to cool.
4. Properly disconnect the battery.

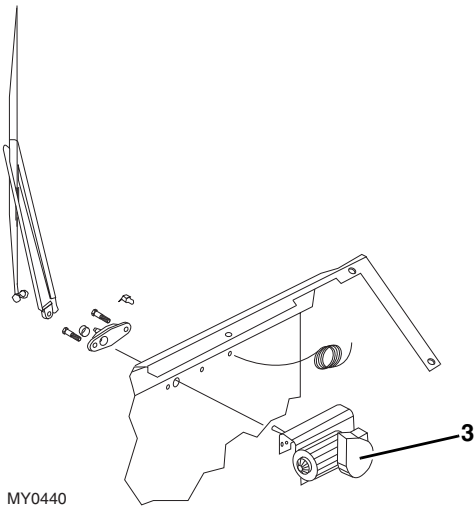

5. Remove the screws that secure the main dash panel. Pull out the dash panel to gain access to the wiper motor (3).
6. Disconnect the cab harness connectors from the wiper motor.
7. Remove the linkage attached to the wiper motor.
8. Loosen and remove the four bolts holding the wiper motor to the mounting bracket.

Note: Retain all hardware removed from the wiper assembly for possible reuse on the replacement motor housing.

9. Remove the motor from the inside of the cab.

b. Disassembly

DO NOT disassemble the motor. The motor is not serviceable. Replace motor if found to be defective.

c. Inspection and Replacement

Inspect the motor terminals for continuity. Replace motor if continuity is not found.

d. Installation and Testing

1. Install all required hardware to the motor assembly.
2. Align motor with the mounting holes and bolt the motor to the mounting bracket.
3. Connect the wiper linkage to the wiper motor shaft.
Note: Align the wiper linkage arm with the flat on the motor shaft to ensure wiper stroke covers window area, and it does not swipe past the glass area.
4. Connect the cab harness connectors to windshield wiper motor connectors.
5. Replace the main dash panel to its original orientation. Secure with the previously used screws.
6. Properly connect the battery.
7. Turn ignition key switch to the RUN position, and operate windshield wiper in both LOW and HIGH speeds to ensure proper operation and that correct wiper travel is achieved.
8. If previously removed, install hydraulic hoses under the dash. (Refer to Section 4.3.1, “Steering Column and Orbitrol Valve.”)
9. Close and secure the engine cover.
10. Remove the Do Not Operate Tags from both the ignition key switch and the steering wheel.

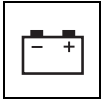

9.9.1 Windshield/Rear Window Washer Reservoir

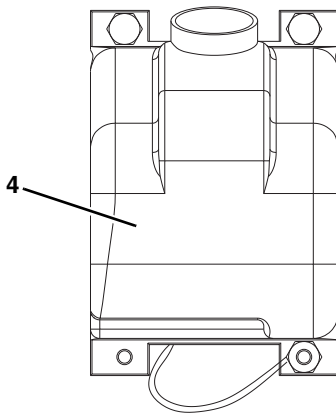

MY0420

The windshield washer motor and reservoir (4) is located in the cab behind the seat. It is labeled as a unit and cannot be serviced separately.

a. Removal

1. Park the machine on a firm, level surface, level the machine, fully retract the boom, lower the boom, place the transmission control lever in (N) NEUTRAL, engage the park brake and shut the engine OFF.
2. Place a Do Not Operate Tag on both the ignition key switch and the steering wheel, stating that the machine should not be operated.
3. Open the engine cover. Allow the system fluids to cool.
4. Properly disconnect the battery.
5. Remove the nuts and the lock washers from the washer mounting bolts.
6. Pull the washer reservoir out and away from the mounting bracket.
7. Rotate the washer reservoir, label and remove the cab harness connectors from the washer reservoir connectors.
8. Remove the windshield washer hoses from the reservoir.

b. Disassembly

DO NOT disassemble the pump. The pump is not serviceable. Replace pump if found to be defective.

c. Installation and Testing

1. Connect the windshield washer hoses to the reservoir.

2. Connect the cab wiring harness connectors to the reservoir connectors.
 3. Install the reservoir tank onto the mounting bracket.
- Note:** Attach the ground strap to the lower right bolt hole of washer bottle.
4. Install the lock washers and nuts and secure.
 5. Fill the washer fluid reservoir with washer fluid.
 6. Properly connect the battery.
 7. Turn the ignition key switch to the RUN position and press the washer switch. Verify that fluid is sprayed on both the windshield and rear glass.
 8. Close and secure the engine cover.
 9. Remove the Do Not Operate Tags from both the ignition key switch and the steering wheel.

9.10 CAB HEATER/AC AND FAN

9.10.1 Cab Heater/AC Controls

Note: If the suspect component is found to be within the heater box, the heater box must be removed as a complete unit and replaced.

a. Cab Heater/AC Controls Removal

TL642 - Before S/N TBK01167 excluding TBL01162

TL943 - Before S/N TBL01599 excluding TBL01551 & TBL01585

1. Park the machine on a firm, level surface, level the machine, fully retract the boom, lower the boom, place the transmission control lever in (N) NEUTRAL, engage the park brake and shut the engine OFF.
2. Place a Do Not Operate Tag on both the ignition key switch and the steering wheel, stating that the machine should not be operated.
3. Open the engine cover. Allow the system fluids to cool.
4. Properly disconnect the battery.

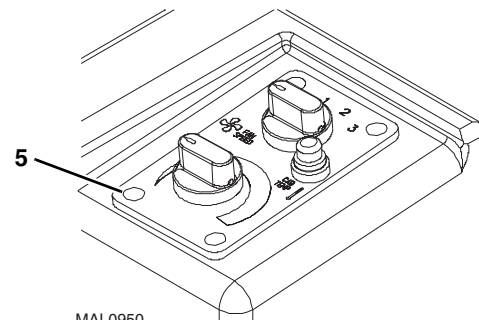

MAL0950



Electrical System

5. Remove the four screws (5) from the cab heater and fan control panel.
6. Pull the control panel out from the dash panel and disconnect the variable speed fan control cab harness connector and disconnect the temperature cable.
7. Remove the control from the panel.

a. Cab Heater/AC Controls Removal

TL642 - S/N TBK01167 & After including TBL01162

TL943 - S/N TBL01599 & After including TBL01551 & TBL01585

1. Park the machine on a firm, level surface, level the machine, fully retract the boom, lower the boom, place the transmission control lever in (N) NEUTRAL, engage the park brake and shut the engine OFF.
2. Place a Do Not Operate Tag on both the ignition key switch and the steering wheel, stating that the machine should not be operated.
3. Open the engine cover. Allow the system fluids to cool.
4. Properly disconnect the battery.

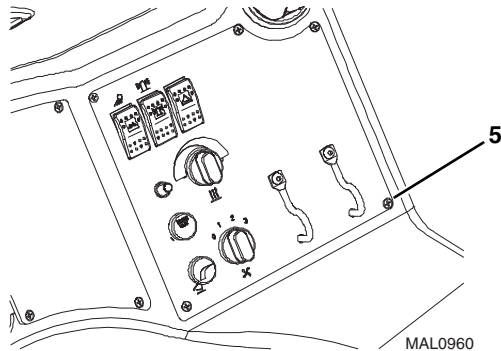

5. Remove the five screws (5) from the right dash panel.
6. Pull the panel out from the dash panel and disconnect the variable speed fan control cab harness connector and disconnect the temperature cable.
7. Remove the control from the panel.

b. Disassembly

DO NOT disassemble the cab heater and fan controls. The controls are not serviceable. Replace controls if found to be defective.

c. Installation and Testing

1. Check that the variable speed fan control is in the OFF position.
2. Install the temperature control cable to the back of the control.
3. Install the hex locknut on the shaft and tighten.
4. Connect the cab harness connector to the variable speed fan control.
5. Install the screws securing the control panel to the dash panel.
6. Properly connect the battery.
7. Turn the ignition key to the ON position and check the fan speeds. If further repair is needed, refer to Section 9.5, "Electrical System Schematics."
8. Start the machine and allow engine to warm to operating temperature. Check heat control at different levels.
9. Close and secure the engine cover.
10. Remove the Do Not Operate Tags from both the ignition key switch and the steering wheel.

9.11 SWITCHES, SOLENOIDS AND SENDERS

9.11.1 Priority Valve

a. Priority Valve Solenoid Removal

1. Park the machine on a firm, level surface, level the machine, fully retract the boom, lower the boom, place the transmission control lever in (N) NEUTRAL, engage the park brake and shut the engine OFF.
2. Place a Do Not Operate Tag on both the ignition key switch and the steering wheel, stating that the machine should not be operated.
3. Open the engine cover. Allow the system fluids to cool.
4. Properly disconnect the battery.
5. Disconnect the wiring connector at the priority valve solenoid lead.

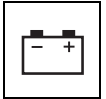

TL642 - S/N TBK01167 and After

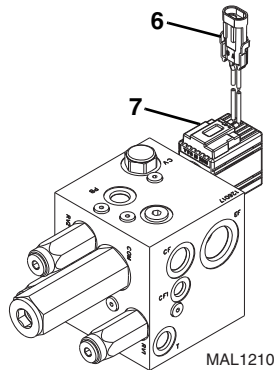

TL943 - Before S/N TBL01599 excluding TBL01551 & TBL01585

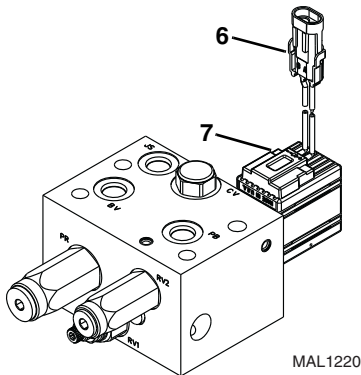

TL943 - S/N TBL01599 & After including TBL01551 & TBL01585

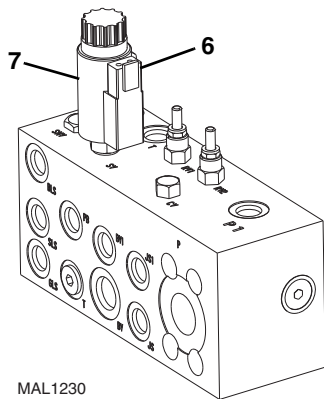

6. Remove the nut on the end of the priority valve coil (6).
7. Remove the priority valve coil.
8. Remove the priority valve solenoid (7). (Remove only if the electrical coil is found to not be faulty.)

b. Disassembly

DO NOT disassemble the solenoid. The solenoid is not serviceable. Replace solenoid if found to be defective.

c. Priority Valve Solenoid Installation

Note: ALWAYS replace seals, o-rings, gaskets, etc., with new parts to help ensure proper sealing and operation. Lubricate seals and o-rings with clean hydraulic oil.

1. If necessary, install the priority valve solenoid in its original orientation.
2. Slide the park brake coil over the solenoid. Tighten the nut to secure the solenoid. **DO NOT** overtighten.
3. Connect the wiring connector to the priority valve coil lead.
4. Properly connect the battery.
5. Close and secure the engine cover.
6. Remove the Do Not Operate Tags from both the ignition key switch and the steering wheel.

9.11.2 Transmission Solenoid Valves

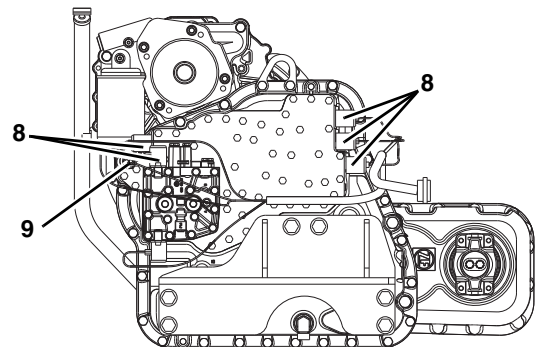

Note: If the transmission is not shifting properly, the transmission shift control switch (travel select lever), wiring harness or transmission shift solenoids (8) should be checked in order to determine which component is defective. Specific information to determine which travel position and corresponding component is not responding can be found in the detailed transmission service instructions. Refer to Section 6.3, "Transmission Specifications and Maintenance Information."

The transmission should be checked, serviced and repaired only by experienced service technicians who are aware of all safety instructions and particular component features.

Note: Contact your local Service Department if internal transmission repair is required during the warranty period.



Electrical System

9.11.3 Transmission Temperature Switch

a. Transmission Temperature Switch Removal

The transmission temperature switch (9) is located at the bottom left side of the transmission housing.

1. Park the machine on a firm, level surface, level the machine, fully retract the boom, lower the boom, place the transmission control lever in (N) NEUTRAL, engage the park brake and shut the engine OFF.
2. Place a Do Not Operate Tag on both the ignition key switch and the steering wheel, stating that the machine should not be operated.
3. Open the engine cover. Allow the system fluids to cool.
4. Properly disconnect the battery.
5. Unplug the transmission temperature switch connector from the wiring harness connector.
6. The switch is threaded into the transmission housing. Remove the switch.

b. Transmission Temperature Switch Inspection and Replacement

Inspect the switch and the wiring harness connector terminals for continuity. Replace a defective or faulty switch with a new part.

c. Transmission Temperature Switch Installation and Testing

1. Thread the transmission temperature switch into the transmission housing snugly, then connect the switch connector to the wiring harness connector.
2. Properly connect the battery.
3. Check for proper fluid level.
4. Start the engine, allow it to reach operating temperature and observe the operator display cluster for warning indication. If the switch is not defective, the problem could be elsewhere; possibly in a shorted wire, damaged transmission, improper or low fluid, etc.
5. Close and secure the engine cover.
6. Remove the Do Not Operate Tags from both the ignition key switch and the steering wheel.

9.11.4 Engine Coolant Temperature Sensor

a. Engine Coolant Temperature Sensor Removal

1. Park the machine on a firm, level surface, level the machine, fully retract the boom, lower the boom, place the transmission control lever in (N) NEUTRAL, engage the park brake and shut the engine OFF.
2. Place a Do Not Operate Tag on both the ignition key switch and the steering wheel, stating that the machine should not be operated.
3. Open the engine cover. Allow the system fluids to cool.
4. Properly disconnect the battery.
5. Unplug the engine coolant temperature sensor connector from the wiring harness connector.

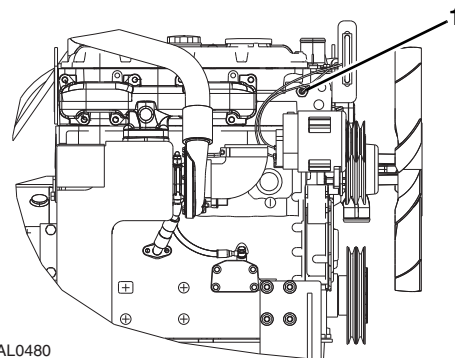

6. The Engine Coolant Temperature sensor (1) is threaded into the engine block. Remove the sensor.

b. Engine Coolant Temperature Sensor Inspection and Replacement

Inspect the sensor and the wiring harness connector terminals for continuity. Replace a defective or faulty sensor with a new part.

c. Engine Coolant Temperature Sensor Installation and Testing

1. Thread the engine coolant temperature sensor into the engine block snugly, then connect the sensor connector to the wiring harness connector.
2. Properly connect the battery.
3. Check for proper coolant level.

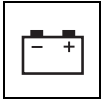

4. Start the engine, allow it to reach operating temperature and observe the operator instrument cluster for warning indication. If the sensor is not defective, the problem could be elsewhere; possibly in a shorted wire, improper-running engine, improper or low coolant, obstructed or faulty radiator, coolant pump, loose fan belt, defective instrument display, etc.
5. Close and secure the engine cover.
6. Remove the Do Not Operate Tags from both the ignition key switch and the steering wheel.

9.11.5 Engine Oil Pressure Sender/Sensor

TL642 - Before S/N TBK01167 excluding TBK01162

TL943 - Before S/N TBL01599 excluding TBL01551 & TBL01585

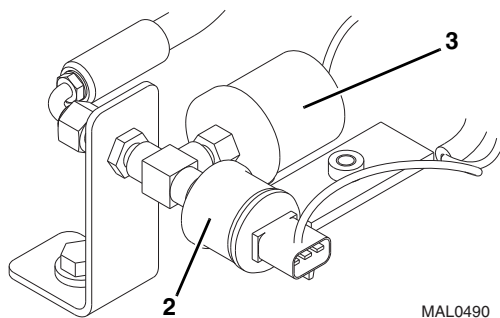

The Engine Oil Pressure Sender (2) and Engine Oil Pressure Sensor (3) are located on the right side of the engine mounted to the engine compartment floor.

a. Engine Oil Pressure Sender/Sensor Removal

1. Park the machine on a firm, level surface, level the machine, fully retract the boom, lower the boom, place the transmission control lever in (N) NEUTRAL, engage the park brake and shut the engine OFF.
2. Place a Do Not Operate Tag on both the ignition key switch and the steering wheel, stating that the machine should not be operated.
3. Open the engine cover. Allow the system fluids to cool.
4. Properly disconnect the battery.
5. Unplug the engine oil pressure sender/sensor connector from the wiring harness connector.
6. Remove the sender/sensor.

b. Engine Oil Pressure Sender/Sensor Inspection and Replacement

Inspect the sender/sensor and the wiring harness connector terminals for continuity. Replace a defective or faulty sender/sensor with a new part.

c. Engine Oil Pressure Sender/Sensor Installation and Testing

1. Thread the engine oil pressure sender/sensor into the threaded mount snugly, then connect the sender/sensor connector to the wiring harness connector.
2. Properly connect the battery.
3. Check for proper oil level.
4. Start the engine, and observe the operator display for warning indication. If the sender/sensor is not defective, the problem could be elsewhere; possibly in a shorted wire, improper-running engine, low oil, obstructed or faulty oil pump, defective instrument display.
5. Close and secure the engine cover.
6. Remove the Do Not Operate Tags from both the ignition key switch and the steering wheel.

9.11.6 Fuel Level Sender

a. Fuel Level Indicator Testing

1. The fuel level sender wiring harness leads can be accessed from the top of the fuel tank. Disconnect the fuel level sender wiring harness leads. With the help of an assistant, touch both harness leads together.
2. From the operator cab, have the assistant turn the ignition key switch to the RUN position. **DO NOT** start the engine. Observe the fuel level indicator needle on the operator instrument cluster. The reading must be at the FULL mark.
3. Turn the ignition key switch to the OFF position. The fuel level indicator needle should return to the EMPTY position.



Electrical System

b. Fuel Level Circuit Tests

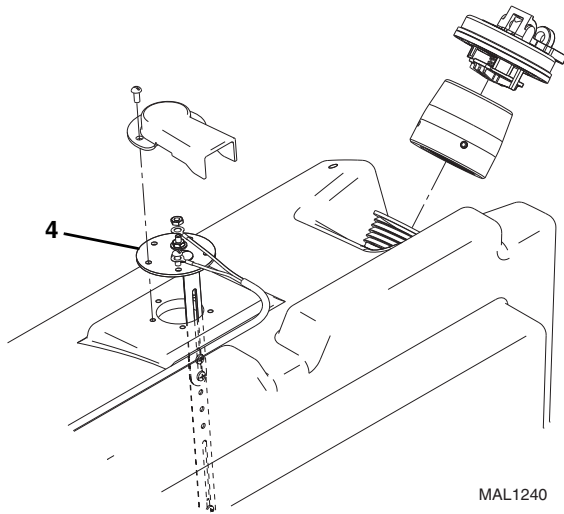

If the fuel level sender (4) is suspected of giving a false reading, perform the following checks:

1. If the fuel level indicator needle does not move, check the fuel tank for fuel.
2. Check for loose or defective wiring, faulty ground connections, and corrosion on the fuel tank sender and wiring lead.
3. If the fuel level indicator needle does not move after the ignition key switch is turned to the RUN position, use a test lamp to determine whether current is flowing from the ignition switch to the fuel level sender.
4. If the fuel level indicator does not move and a faulty or defective fuel level sender in the fuel tank has been ruled out, and in addition, wiring and connectors have been checked and ruled out, the fuel level indicator is defective and must be replaced.
5. Check that the ignition terminal has current and that the fuse in the fuse panel is not blown.
6. Check for broken, shorted, frayed, disconnected or damaged wiring between the fuel level indicator wiring at the cab, fuse and relay panel, ignition key switch, and from the fuel level sender on the fuel tank through the wiring in the cab.
7. Check the fuel level sender. A defective fuel level sender in the fuel tank may also prevent the fuel level indicator from moving. Refer to Section 9.5, "Electrical System Schematics," for further information.

9.12 GAUGES AND DISPLAY MONITOR

9.12.1 Analog Gauges

TL642 - Before S/N TBK01167 excluding TBK01162

TL943 - Before S/N TBL01599 excluding TBL01551 & TBL01585

a. Removal

1. Park the machine on a firm, level surface, level the machine, fully retract the boom, lower the boom, place the transmission control lever in (N) NEUTRAL, engage the park brake and shut the engine OFF.
2. Place a Do Not Operate Tag on both the ignition key switch and the steering wheel, stating that the machine should not be operated.
3. Open the engine cover. Allow the system fluids to cool.
4. Properly disconnect the battery.

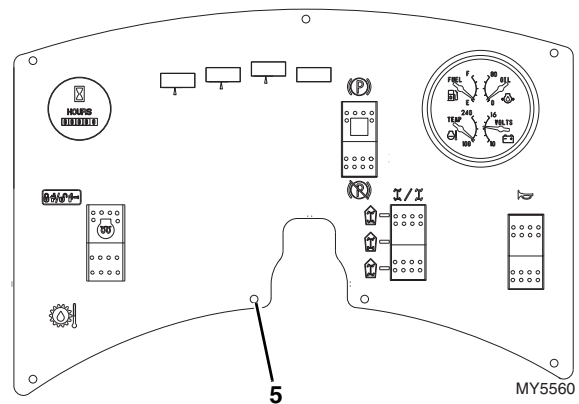

5. Remove the seven screws (5) securing the dash panel.
6. Label and disconnect the wires from the gauge, remove the gauge bracket.
7. Pull the gauge out from the dash.

b. Disassembly

DO NOT disassemble the gauge. The gauge is not serviceable. Replace the gauge if found to be defective.

c. Installation and Testing

1. Install the gauge in the dash. Install the gauge bracket.
2. Connect the previously labeled wires to the gauge.
3. Install the dash panel with the previously used hardware.

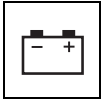

4. Properly connect the battery.
5. Turn the ignition to the ON position to check the gauge values.
6. Close and secure the engine cover.
7. Remove the Do Not Operate Tags from both the ignition key switch and the steering wheel.

9.12.2 3-N-1 Digital Gauge

TL642 - S/N TBK01167 & After including TBL01162
TL943 - S/N TBL01599 & After including TBL01551 & TBL01585

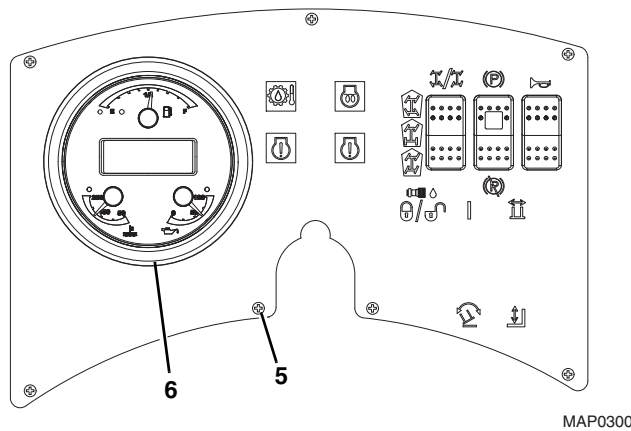

The 3-N-1 gauge (6) is located on the center dash panel. The digital display in the center of the gauge displays the operating hours, voltmeter and engine speed on the left hand side and engine fault codes or machine diagnostic trouble codes (DTC's) on the right hand side.

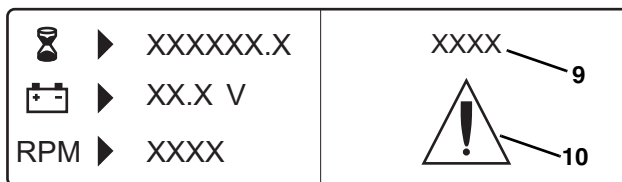
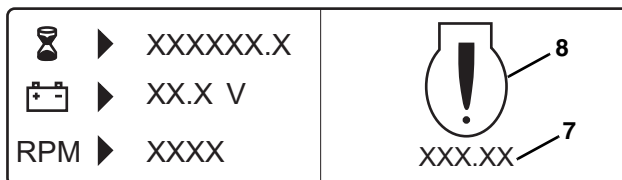

MAP0640

Engine fault codes (7) will be displayed with the engine fault symbol (8) and the numeric fault code value below the symbol. Machine DTC's (9) will be displayed with the machine fault symbol (10) and the numeric DTC value above the symbol.

Note: For engine fault codes, refer to Section 9.15, "Engine Diagnostic and Event Codes (S/N TBK01167 & After including TBK01162; S/N TBL01599 & After including TBL01551 & TBL01585)," or contact the local Caterpillar dealer.

a. Gauge Removal

1. Park the machine on a firm, level surface, level the machine, fully retract the boom, lower the boom, place the transmission control lever in (N) NEUTRAL, engage the park brake and shut the engine OFF.
2. Place a Do Not Operate Tag on both the ignition key switch and the steering wheel, stating that the machine should not be operated.
3. Open the engine cover. Allow the system fluids to cool.
4. Properly disconnect the battery.
5. Remove the screws (5) securing the dash panel.
6. Label and disconnect the wires from the gauge, remove the gauge bracket.
7. Pull the gauge out from the dash.

b. Disassembly

DO NOT disassemble the gauge. The gauge is not serviceable. Replace the gauge if found to be defective.

c. Gauge Installation and Testing

1. Install the gauge in the dash. Install the gauge bracket.
2. Connect the previously labeled wires to the gauge.
3. Install the dash panel with the previously used hardware.
4. Properly connect the battery.
5. Turn the ignition to the ON position to check the gauge values.
6. Close and secure the engine cover.
7. Remove the Do Not Operate Tags from both the ignition key switch and the steering wheel.



Electrical System

9.13 DASH SWITCHES

Note: For information on the front windshield wiper, rear window wiper and washer systems, refer to Section 9.9, "Window Wiper/Washer Windshield Wiper Motor."

9.13.1 Ignition Key Switch

a. Ignition Switch Removal

1. Park the machine on a firm, level surface, level the machine, fully retract the boom, lower the boom, place the transmission control lever in (N) NEUTRAL, engage the park brake and shut the engine OFF.
2. Place a Do Not Operate Tag on both the ignition key switch and the steering wheel, stating that the machine should not be operated.
3. Open the engine cover. Allow the system fluids to cool.
4. Properly disconnect the battery.
5. Remove the screws securing the dash panel.
6. Remove the hex nut securing the ignition key switch to the dash.
7. Label and disconnect the ignition switch wires and remove the switch from the machine.

b. Disassembly

DO NOT disassemble the ignition switch. Replace a defective switch with a new part.

c. Inspection and Replacement

To determine the proper operation of the ignition key switch, test the terminals on the back of the switch for continuity with an ohmmeter.

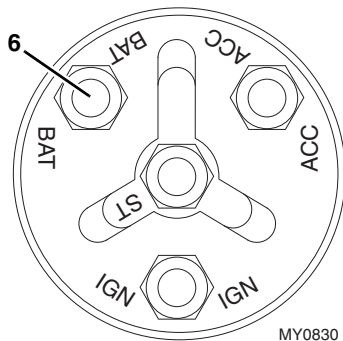

Test the ignition key switch for continuity, by checking from the BAT terminal (6) to each of the remaining terminals in their corresponding switch position.

If all terminals do not show proper continuity, replace the ignition switch.

d. Ignition Switch Installation

1. Connect the ignition key switch to the previously labeled wires.
2. Align the ignition switch in the dash so that when it is in the OFF position, the key slot is positioned vertically (straight up and down). Install the hex nut securing the ignition switch to the dash. **DO NOT** overtighten.
3. Install the dash panel with the previously used hardware.
4. Properly connect the battery.
5. Close and secure the engine cover.
6. Remove the Do Not Operate Tags from both the ignition key switch and the steering wheel.

Note: If further information is needed, refer to Section 9.5, "Electrical System Schematics."

9.13.2 Dash Switches

a. Switch Removal

1. Park the machine on a firm, level surface, level the machine, fully retract the boom, lower the boom, place the transmission control lever in (N) NEUTRAL, engage the park brake and shut the engine OFF.
2. Place a Do Not Operate Tag on both the ignition key switch and the steering wheel, stating that the machine should not be operated.
3. Open the engine cover. Allow the system fluids to cool.
4. Properly disconnect the battery.
5. Pull the frame out of the dash, disconnect the harness connector to the switch in question and push the switch out of the frame.

b. Disassembly

DO NOT disassemble the dash switch. Replace a defective switch with a new part.

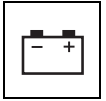

c. Inspection and Replacement

Inspect the switch terminals for continuity and shorting in both the engaged and disengaged positions. Replace a defective or faulty switch with a new switch.

d. Switch Installation

1. Connect the switch to the cab harness connector.
2. Position the switch over the rectangular switch bezel and snap into position.
3. Properly connect the battery.
4. Start the machine and check the replaced switch for proper function.
5. Close and secure the engine cover.
6. Remove the Do Not Operate Tags from both the ignition key switch and the steering wheel.

9.13.3 Rheostat Switch (if equipped)

TL642 - Before S/N TBK01167 excluding TBK01162

TL943 - Before S/N TBL01599 excluding TBL01551 & TBL01585

a. Rheostat Switch Removal

1. Park the machine on a firm, level surface, level the machine, fully retract the boom, lower the boom, place the transmission control lever in (N) NEUTRAL, engage the park brake and shut the engine OFF.
2. Place a Do Not Operate Tag on both the ignition key switch and the steering wheel, stating that the machine should not be operated.
3. Open the engine cover. Allow the system fluids to cool.
4. Properly disconnect the battery.

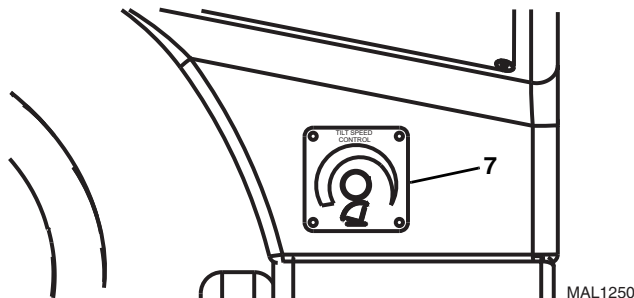

5. Remove the four screws securing the switch (7) to the dash.
6. Disconnect the harness connector to the switch and remove the switch.

b. Disassembly

DO NOT disassemble the Rheostat switch. Replace a defective switch with a new part.

c. Inspection and Replacement

Inspect the switch terminals for continuity and shorting. Replace a defective or faulty switch with a new switch.

d. Switch Installation

1. Connect the switch to the cab harness connector.
2. Position the switch it's original orientation. Secure with the previously used hardware.
3. Properly connect the battery.
4. Start the machine and check the replaced switch for proper function.
5. Close and secure the engine cover.
6. Remove the Do Not Operate Tags from both the ignition key switch and the steering wheel.

TL642 - S/N TBK01167 & After including TBL01162

a. Rheostat Switch Removal

1. Park the machine on a firm, level surface, level the machine, fully retract the boom, lower the boom, place the transmission control lever in (N) NEUTRAL, engage the park brake and shut the engine OFF.
2. Place a Do Not Operate Tag on both the ignition key switch and the steering wheel, stating that the machine should not be operated.
3. Open the engine cover. Allow the system fluids to cool.
4. Properly disconnect the battery.

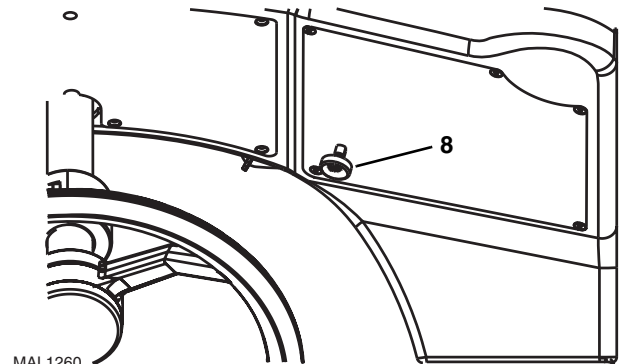

5. Remove the five screws securing the switch panel to the dash.



Electrical System

- Disconnect the harness connector to the switch (8) and remove the switch.

b. Disassembly

DO NOT disassemble the Rheostat switch. Replace a defective switch with a new part.

c. Inspection and Replacement

Inspect the switch terminals for continuity and shorting. Replace a defective or faulty switch with a new switch.

d. Switch Installation

- Connect the switch to the cab harness connector.
- Position the switch in its original orientation. Secure with the previously used hardware.
- Install the switch panel with the previously removed hardware.
- Properly connect the battery.
- Start the machine and check the replaced switch for proper function.
- Close and secure the engine cover.
- Remove the Do Not Operate Tags from both the ignition key switch and the steering wheel.

9.14 HAND HELD ANALYZER (S/N TBL01599 & AFTER INCLUDING TBL01551 & TBL01585)

The hand held analyzer can be used in place of the cab display panel.

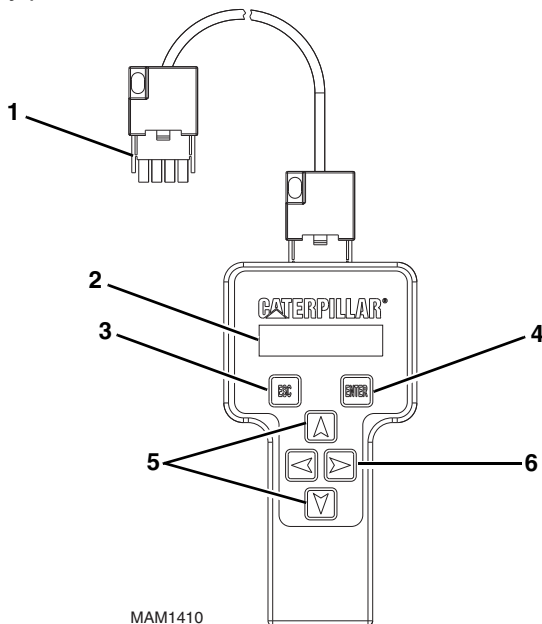

- Cable Connector.
- Analyzer Display Screen.
- Escape Key: To return home or access previous menu.
- Enter Key: Stores and selects Top Level, Sub Level and Items Menus.
- Up/Down Arrow Keys: Change adjustable values.
- Left and Right Arrow Keys: Used to move between Top Level, Sub Levels and Item Menus.

9.14.1 Analyzer Usage

Help messages can be viewed using the Analyzer (P/N 330-5251). The Help messages can be accessed by pressing the ENTER key while viewing the current Help message. The Help message shall be EVERYTHING OK when no fault is present.

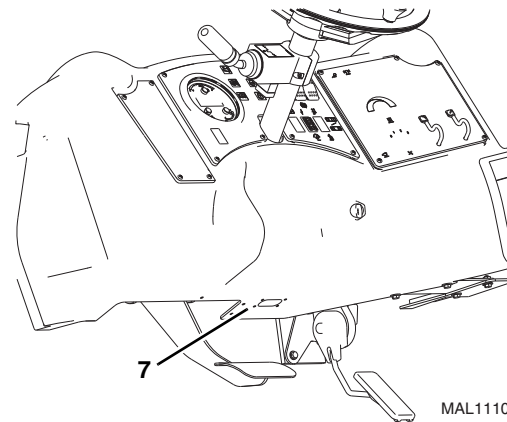

The Analyzer cable plugs into the UGM connector under the right side dash (7).

For more information, contact the local Caterpillar dealer.

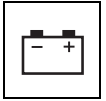

9.14.2 Analyzer Software Version A

The Access Level Menu controls security for Control Module settings. Access Level 2 is the default and allows view access to all menus, except Calibration. Access Level 1 (33271) provides view, edit and calibration authorization.
Note: The layout shows all possible analyzer screens. Please note, some screens may not be available depending upon machine configuration.

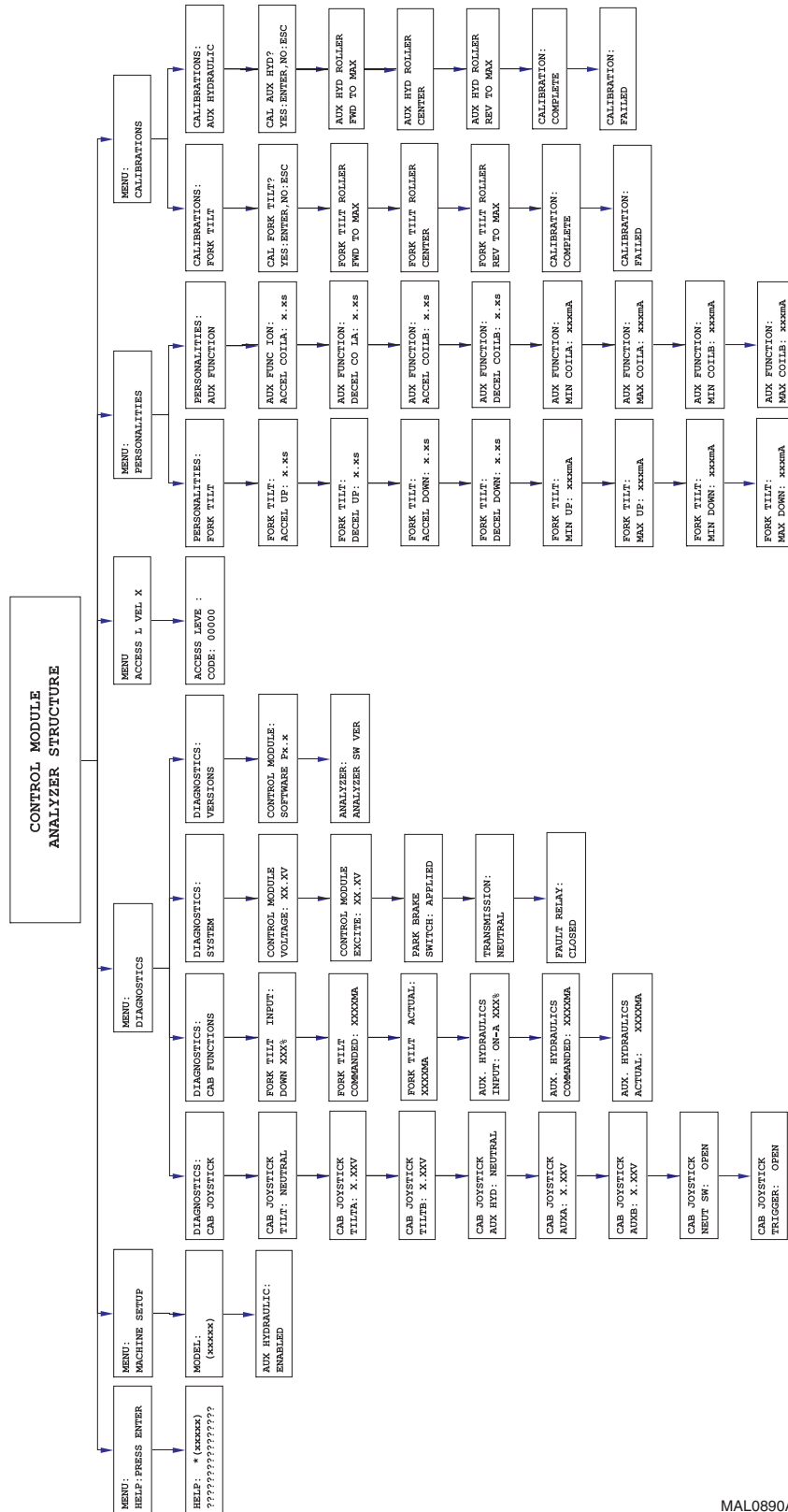

MAL0890A



Electrical System

9.14.3 Personality Settings

MENU	MIN	MAX	DEFAULT
Fork Tilt:			
ACCEL UP: x.xS	0.0	5.0	0.1
DECEL UP: x.xS	0.0	5.0	0.3
ACCEL DOWN: x.xS	0.0	5.0	0.1
DECEL DOWN: x.xS	0.0	5.0	0.3
MIN UP: xxxmA	100	1000	300
MAX UP: xxxmA	500	1700	1100
MIN DOWN: xxxmA	100	1000	300
MAX DOWN: xxxmA	500	1700	1100
AUX FUNCTION:			
ACCEL COILA: x.xS	0.0	5.0	0.1
DECEL COILA: x.xS	0.0	5.0	0.3
ACCEL COILB: x.xS	0.0	5.0	0.1
DECEL COILB: x.xS	0.0	5.0	0.3
MIN COILB: xxxmA	100	1000	300
MAX COILA: xxxmA	500	1700	1100
MIN COILB: xxxmA	100	1000	300
MAX COILB: xxxmA	500	1700	1100

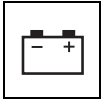

9.14.4 Tilt/Auxiliary Calibration Menu

MENU	SUB-MENU	COMMENT
Calibrations: Fork Tilt	Cal. Fork Tilt? Yes: Enter, No:ESC	The technician will press the ENTER key to initiate calibration, or the ESC key to leave menu.
	Fork Tilt Roller FWD to Max	The technician will knurl the fork tilt roller to the +AR position and press the ENTER key to confirm.
	Fork Tilt Roller Center	The the technician will release the fork tilt roller and press the ENTER key to confirm.
	Fork Tilt Roller REV to Max	The technician will knurl the fork tilt roller to the - AR position and press the ENTER key to confirm.
	Calibrations: Complete	The control system will display this message to advise that the procedure was successful. The technician will press the ESC key to leave this menu.
	Calibrations: Failed	The control system will display this message to advise that the procedure was unsuccessful. The technician will press the ESC key to leave this menu.
Calibrations: Aux Hydraulic	Cal. Aux Hyd? Yes: Enter, No:ESC	The technician will press the ENTER key to initiate calibration, or the ESC key to leave menu.
	Aux Hyd Roller FWD to Max	The technician will knurl the auxiliary hydraulic roller to the +AR position and press the ENTER key to confirm.
	Aux Hyd Roller Center	The the technician will release the auxiliary hydraulic roller and press the ENTER key to confirm.
	Aux Hyd Roller REV to Max	The technician will knurl the auxiliary hydraulic roller to the - AR position and press the ENTER key to confirm.
	Calibrations: Complete	The control system will display this message to advise that the procedure was successful. The technician will press the ESC key to leave this menu.
	Calibrations: Failed	The control system will display this message to advise that the procedure was unsuccessful. The technician will press the ESC key to leave this menu.



Electrical System

9.14.5 Joystick Fault Codes

DTC	Event	Comment	Latched
211	Power Cycle	<ul style="list-style-type: none">• No motion restrictions• This Help Message is issued at each power-up. This serves to indicate which messages have been recorded in Logged Help since the last power-up event.	No
2127	Aux Joystick Not In Neutral Position At Power Up	<ul style="list-style-type: none">• Auxiliary Hydraulic A & B prevented• The auxiliary hydraulic joystick must be in the neutral position (established by Calibration) when the control system is energized or it is ignored until it momentarily returns to neutral.• Active when AUX HYDRAULIC is ENABLED	No
2123	Joystick Trigger Switch Active At Power Up	<ul style="list-style-type: none">• De-Clutch functionality prevented (transmission always engaged)• The trigger for de-clutch should be open (released) when the control system is energized or is ignored until it momentarily opens.	No
2125	Joystick Left Roller Not In The Neutral Position At Power Up	<ul style="list-style-type: none">• Fork Tilt Up & Down prevented• The left roller must be in the neutral position (established by Calibration) when the control system is energized or it is ignored until it momentarily returns to neutral.	No
2126	Joystick Right Roller Not In The Neutral Position At Power Up	<ul style="list-style-type: none">• Auxiliary Hydraulic A & B prevented• The right roller must be in the neutral position (established by Calibration) when the control system is energized or it is ignored until it momentarily returns to neutral.	No
2356	Auxiliary Hydraulic Joystick - Neutral Disagreement	<ul style="list-style-type: none">• Auxiliary Hydraulic A & B prevented• The auxiliary joystick's neutral switch was open while the analog voltage was in the active range, or the neutral switch was closed while the analog voltage was in the neutral range. Auxiliary hydraulics will be prevented until the next power cycle. This fault may be caused by improper joystick calibration, improper wiring, a joystick issue or a control module issue.• Neutral switch must be open for 0%; closed beyond $\pm 25\%$	Yes

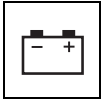

DTC	Event	Comment	Latched
2357	Auxiliary Hydraulic Joystick - Out Of Range High	<ul style="list-style-type: none"> • Auxiliary Hydraulic A & B prevented • The auxiliary joystick analog voltage was measured to be greater than 4.85V. Auxiliary hydraulics will be prevented until the next power cycle. This fault may be caused by improper wiring, a joystick issue or a control module issue. • Active when Machine Setup's AUX HYDRAULIC is set to ENABLED 	Yes
2358	Auxiliary Hydraulic Joystick - Out Of Range Low	<ul style="list-style-type: none"> • Auxiliary Hydraulic A & B prevented • The auxiliary joystick's analog voltage was measured to be less than 0.15V. Auxiliary hydraulics will be prevented until the next power cycle. • Active when Machine Setup's AUX HYDRAULIC is set to ENABLED 	Yes
2397	Fork Tilt Joystick - Voltage Disagreement	<ul style="list-style-type: none"> • Fork Tilt Up & Down prevented • Analog feedback from the joystick's tilt roller did not agree within $\pm 25\%$ for 1000mS. Fork tilt up and down will be prevented until the next power cycle. This fault may be caused by improper wiring, a joystick issue or a control module issue. 	Yes
2398	Fork Tilt Joystick - Out Of Range High	<ul style="list-style-type: none"> • Fork Tilt Up & Down prevented • Analog feedback from the joystick's tilt roller was measured to be greater than 4.85V. Fork tilt up and down will be prevented until the next power cycle. This fault may be caused by improper wiring, a joystick issue or a control module issue. 	Yes
2399	Fork Tilt Joystick - Out Of Range Low	<ul style="list-style-type: none"> • Fork Tilt Up & Down prevented • Analog feedback from the joystick's tilt roller was measured to be less than 0.15V. Fork tilt up and down will be prevented until the next power cycle. This fault may be caused by improper wiring, a joystick issue or a control module issue. 	Yes
33191	Fork Tilt Valve - Open Circuit	<ul style="list-style-type: none"> • The desired current is greater than 250mA, but the actual current is less than 75mA • The fork tilt up digital output was open-circuit. This fault may be caused by improper wiring or a control module issue. 	Yes

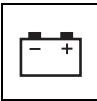

Electrical System

DTC	Event	Comment	Latched
33192	Fork Tilt Valve - Short To Battery	<ul style="list-style-type: none"> Fork Tilt Up & Down, Auxiliary Hydraulics functionality prevented The fork tilt up or down digital output was shorted to battery. Fork tilt up or down will be prevented until the next powercycle. This fault may be caused by improper wiring or a control module issue. The desired current is greater than 250mA, but the actual current is less than 75mA. 	Yes
33193	Fork Tilt Up Valve - Short To Ground	<ul style="list-style-type: none"> The actual current is greater than 200mA, PWM is 95%, and the digital output driver's diagnostic feedback is low The fork tilt up digital output was shorted to ground. This fault may be caused by improper wiring or a control module issue. 	Yes
33194	Fork Tilt Down Valve - Open Circuit	<ul style="list-style-type: none"> The desired current is greater than 250mA, but the actual current is less than 75mA The fork tilt down digital output was open-circuit. This fault may be caused by improper wiring or a control module issue. 	Yes
33195	Fork Tilt Down Valve - Short To Ground	<ul style="list-style-type: none"> The actual current is greater than 200mA, PWM is 95%, and the digital output driver's diagnostic feedback is low The fork tilt down digital output was shorted to ground. This fault may be caused by improper wiring or a control module issue. 	Yes
33196	Auxiliary Function - A Valve - Open Circuit	<ul style="list-style-type: none"> The desired current is greater than 250mA, but the actual current is less than 75mA The auxiliary hydraulic "A" or "B" digital output was open-circuit. This fault may be caused by improper wiring or a control module issue. 	Yes
33197	Auxiliary Function - A/B Valve - Short To Battery	<ul style="list-style-type: none"> Fork Tilt Up & Down, Auxiliary Hydraulics functionality prevented The auxiliary hydraulic "A" digital output was shorted to battery. Auxiliary hydraulics will be prevented until the next power cycle. This fault may be caused by improper wiring or a control module issue. Active when Machine Setup's AUX HYDRAULIC is set to ENABLED The desired current is 0mA and the digital output driver's diagnostic feedback is low Low-Side Fault Relay de-energized 	Yes

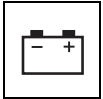

DTC	Event	Comment	Latched
33198	Auxiliary Function - A Valve - Short To Ground	<ul style="list-style-type: none"> • The actual current is greater than 200mA, PWM is 95%, and the digital output driver's diagnostic feedback is low • The auxiliary hydraulic "A" digital output was shorted to ground. This fault may be caused by improper wiring or a control module issue. • Active when Machine Setup's AUX HYDRAULIC is set to ENABLED 	Yes
33199	Auxiliary Function - B Valve - Open Circuit	<ul style="list-style-type: none"> • The desired current is greater than 250mA, but the actual current is less then 75mA • The auxiliary hydraulic "B" digital output was open-circuit. This fault may be caused by improper wiring or a control module issue. • Active when Machine Setup's AUX HYDRAULIC is set to ENABLED 	Yes
33200	Auxiliary Function - B Valve - Short To Ground	<ul style="list-style-type: none"> • The actual current is greater than 200mA, PWM is 95%, and the digital output driver's diagnostic feedback is low • The auxiliary hydraulic "B" digital output was shorted to ground. This fault may be caused by improper wiring or a control module issue. • Active when Machine Setup's AUX HYDRAULIC is set to ENABLED 	Yes
441	Battery Voltage Too Low - System Shutdown	<ul style="list-style-type: none"> • Fork Tilt Up & Down, Auxiliary Hydraulics & De-Clutch functionality prevented • Battery voltage is less than 8.0V so the control module has prevented associated functionality. 	No
442	Battery Voltage Too High - System Shutdown	<ul style="list-style-type: none"> • Fork Tilt Up & Down, Auxiliary Hydraulics & De-Clutch functionality prevented • Battery voltage is greater than 8.0V so the control module has prevented associated functionality. • Low-Side Fault Relay de-energized 	Yes
447	Reference Voltage Out Of Range	<ul style="list-style-type: none"> • Fork Tilt Up & Down, Auxiliary Hydraulics & De-Clutch functionality prevented • The control module's +5V reference was measured greater than 5.4V or less than 4.6V for 1000mS. Since this reference voltage supplies the joystick(s), fork tilt and auxiliary hydraulic functions must be prevented. • Low-Side Fault Relay de-energized 	Yes



Electrical System

DTC	Event	Comment	Latched
998	Eeprom Failure - Check All Settings	<ul style="list-style-type: none"> • Fork Tilt Up & Down, Auxiliary Hydraulics & De-Clutch functionality prevented • The control module detected an issue with the non-volatile memory used to retain Personalities and Calibrations. Verify all settings using the JLG Analyzer. • Low-Side Fault Relay de-energized 	Yes
2239	Function Problem - Joystick Calibration Faulty	<ul style="list-style-type: none"> • Fork Tilt Up & Down, prevented • The joystick calibration has never been performed, is improper or calibration attempt has failed. Recalibrate the Fork Tilt and Auxiliary Hydraulic (optional) joysticks to clear this fault. • Auxiliary Hydraulics prevented if Machine Setup's AUX HYDRAULIC is ENABLED 	No
23100	Auxiliary Hydraulic Joystick - Voltage Disagreement	<ul style="list-style-type: none"> • Auxiliary Hydraulic A & B prevented • Analog feedback from the joystick's auxiliary roller did not agree within $\pm 25\%$ for 1000mS. Auxiliary Hydraulics will be prevented until the next power cycle. This fault may be caused by a joystick issue, improper wiring or a control module issue. 	Yes
259	Model Change - Hydraulics Suspended - Cycle Ems	<ul style="list-style-type: none"> • Fork Tilt Up & Down, Auxiliary Hydraulics & De-Clutch functionality prevented • The user changed the Model Selection using a JLG Analyzer. All functions are being prevented until the EMS is cycled. • Machine Setup's MODEL was changed via JLG Analyzer 	Yes

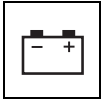

**9.15 ENGINE DIAGNOSTIC AND EVENT CODES
(S/N TBK01167 & After including TBK01162;
S/N TBL01599 & After including TBL01551 & TBL01585)**

CDL Code	Description	CatET J1939 Code	3rd Party Device J1939 Code	Flash Code
N/A	No Diagnostic Code Detected	N/A	N/A	551
0001-02	Cylinder #1 Injector Erratic, Intermittent, or Incorrect	J651-2	651-2	111
0001-05	Cylinder #1 Injector Current Below Normal	J651-5	651-5	111
0001-06	Cylinder #1 Injector Current Above Normal	J651-6	651-6	111
0001-07	Cylinder #1 Injector Not Responding Properly	J651-7	651-7	111
0002-02	Cylinder #2 Injector Erratic, Intermittent, or Incorrect	J652-2	652-2	112
0002-05	Cylinder #2 Injector Current Below Normal	J652-5	652-5	112
0002-06	Cylinder #2 Injector Current Above Normal	J652-6	652-6	112
0002-07	Cylinder #2 Injector Not Responding Properly	J652-7	652-7	112
0003-02	Cylinder #3 Injector Erratic, Intermittent, or Incorrect	J653-2	653-2	113
0003-05	Cylinder #3 Injector Current Below Normal	J653-5	653-5	113
0003-06	Cylinder #3 Injector Current Above Normal	J653-6	653-6	113
0003-07	Cylinder #3 Injector Not Responding	J653-7	653-7	113
0004-02	Cylinder #4 Injector Erratic, Intermittent, or Incorrect	J654-2	654-2	114
0004-05	Cylinder #4 Injector Current Below Normal	J654-5	654-5	114
0004-06	Cylinder #4 Injector Current Above Normal	J654-6	654-6	114
0004-07	Cylinder #4 Injector Not Responding Properly	J654-7	654-7	114
0005-02	Cylinder #5 Injector Erratic, Intermittent, or Incorrect (C6.6 engine only)	J655-2	655-2	115
0005-05	Cylinder #5 Injector Current Below Normal (C6.6 engine only)	J655-5	655-5	115
0005-06	Cylinder #5 Injector Current Above Normal (C6.6 engine only)	J655-6	655-6	115
0005-07	Cylinder #5 Injector Not Responding Properly (C6.6 engine only)	J655-7	655-7	115
0006-02	Cylinder #6 Injector Erratic, Intermittent, or Incorrect (C6.6 engine only)	J656-2	656-2	116
0006-05	Cylinder #6 Injector Current Below Normal (C6.6 engine only)	J656-5	656-5	116

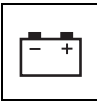

Electrical System

CDL Code	Description	CatET J1939 Code	3rd Party Device J1939 Code	Flash Code
0006-06	Cylinder #6 Injector Current Above Normal (C6.6 engine only)	J656-6	656-6	116
0006-07	Cylinder #6 Injector Not Responding Properly (C6.6 engine only)	J656-7	656-7	116
0041-03	8 Volt DC Supply Voltage Above Normal	J678-03	678-03	517
0041-04	8 Volt DC Supply Voltage Below Normal	J678-04	678-04	517
0091-02	Throttle Position Sensor Erratic, Intermittent, or Incorrect	J91-02	91-02	154
0091-03	Throttle Position Sensor Voltage Above Normal	J91-03	91-03	154
0091-04	Throttle Position Sensor Voltage Below Normal	J91-04	91-04	154
0091-08	Throttle Position Sensor Abnormal Frequency, Pulse Width, or Period	J91-08	91-08	154
0100-03	Engine Oil Pressure Sensor Voltage Above Normal	J100-03	100-03	157
0100-04	Engine Oil Pressure Sensor Voltage Below Normal	J100-04	100-04	157
0100-10	Engine Oil Pressure Sensor Abnormal Rate of Change	J100-10	100-10	157
0110-03	Engine Coolant Temperature Sensor Voltage Above Normal	J110-03	110-03	168
0110-04	Engine Coolant Temperature Sensor Voltage Below Normal	J110-04	110-04	168
0168-00	Electrical System Voltage High	J168-00	168-00	422
0168-01	Electrical System Voltage Low	J168-01	168-01	422
0168-02	Electrical System Voltage Erratic, Intermittent, or Incorrect	J168-02	168-02	422
0172-03	Intake Manifold Air Temperature Sensor Voltage Above Normal	J105-03	105-03	133
0172-04	Intake Manifold Air Temperature Sensor Voltage Below Normal	J105-04	105-04	133
0190-08	Engine Speed Sensor Abnormal Frequency, Pulse Width, or Period	J190-08	190-08	141
0247-09	SAE J1939 Data Link Abnormal Update Rate	-	-	514
0247-12	SAE J1939 Data Link Failure	-	-	514
0253-02	Personality Module Erratic, Intermittent, or Incorrect	J631-02	631-02	415
0261-11	Engine Timing Offset Fault	J637-11	637-11	143

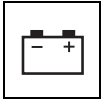

CDL Code	Description	CatET J1939 Code	3rd Party Device J1939 Code	Flash Code
0262-03	5 Volt Sensor DC Power Supply Voltage Above Normal	J1079-03	1079-03	516
0262-04	5 Volt Sensor DC Power Supply Voltage Below Normal	J1079-04	1079-04	516
0268-02	Programmed Parameter Fault Erratic, Intermittent, or Incorrect	J630-02	630-02	527
0342-08	Secondary Engine Speed Sensor Abnormal Frequency, Pulse Width, or Period	J723-08	723-08	142
0526-05	Turbo Wastegate Drive Current Below Normal	J1188-05	1188-05	177
0526-06	Turbo Wastegate Drive Current Above Normal	J1188-06	1188-06	177
0526-07	Turbo Wastegate Drive Not Responding Properly	J1188-07	1188-07	177
0774-02	Secondary Throttle Position Sensor Erratic, Intermittent, or Incorrect	J29-02	29-02	155
0774-03	Secondary Throttle Position Sensor Voltage Above Normal	J29-03	29-03	155
0774-04	Secondary Throttle Position Sensor Voltage Below Normal	J29-04	29-04	155
0774-08	Secondary Throttle Position Sensor Abnormal Frequency, Pulse Width, or Period	J29-08	29-08	155
1639-09	Machine Security System Module Abnormal Update Rate	J1196-09	1196-09	426
1743-02	Engine Operation Mode Selector Switch Erratic, Intermittent, or Incorrect	J2882-02	2882-02	144
1779-05	Fuel Rail #1 Pressure Valve Solenoid Current Below Normal	J1347-05	1347-05	162
1779-06	Fuel Rail #1 Pressure Valve Solenoid Current Above Normal	J1347-06	1347-06	162
1785-03	Intake Manifold Pressure Sensor Voltage Above Normal	J102-03	102-03	197
1785-04	Intake Manifold Pressure Sensor Voltage Below Normal	J102-04	102-04	197
1785-10	Intake Manifold Pressure Sensor Abnormal Rate of Change	J102-10	102-10	197
1797-03	Fuel Rail Pressure Sensor Voltage Above Normal	J157-03	157-03	159
1797-04	Fuel Rail Pressure Sensor Voltage Below Normal	J157-04	157-04	159
1834-02	Ignition Keyswitch Loss of Signal	J158-02	158-02	439

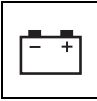

Electrical System

CDL Code	Description	CatET J1939 Code	3rd Party Device J1939 Code	Flash Code
2246-06	Glow Plug Start Aid Relay Current Above Normal	J676-06	676-06	199

Event Code	Description	CatET J1939 Code	3rd Party Device J1939 Code	Flash Code
E172-1	High Air Filter Restriction	J107-15	107-15	151
E194-1	High Exhaust Temperature	J173-15	173-15	185
E232-1	High Fuel/Water Separator Water Level	J97-15	97-15	-
E360-1	Low Oil Pressure - Warning	J100-17	100-17	157
E360-3	Low Oil Pressure - Shutdown	J100-01	100-01	157
E361-1	High Engine Coolant Temperature - Warning	J110-15	110-15	168
E361-2	High Engine Coolant Temperature - Derate	J110-16	110-16	168
E361-3	High Engine Coolant Temperature - Shutdown	J110-00	110-00	168
E362-1	Engine Overspeed	J190-15	190-15	141
E396-1	High Fuel Rail Pressure	J157-00	157-00	159
E398-1	Low Fuel Rail Pressure	J157-01	157-01	159
E539-1	High Intake Manifold Air Temperature - Warning	J105-15	105-15	133
E539-2	High Intake Manifold Air Temperature - Derate	J105-16	105-16	133
E2143-3	Low Engine Coolant Level	J111-01	111-01	169



31200292

CATERPILLAR®