



---

# ***Operation & Safety Manual***

*Keep this manual with machine at all times.*

## ***Telehandler Personnel Work Platform***

TL642 - S/N TBK00100 & AFTER  
TL943 - S/N TBL00100 & AFTER  
TL1055 - S/N TBM00100 & AFTER  
TL1255 - S/N TBN00100 & AFTER  
TH255 - S/N TBS00100 & AFTER  
TH406 - S/N TBX00100 & AFTER  
TH407 - S/N TBY00100 & AFTER

**31200261**

*Revised  
February 14, 2008*



**CALIFORNIA PROPOSITION 65**  
**BATTERY WARNING**

**Battery posts,  
terminals and related  
accessories contain  
lead and lead compounds,  
chemical known to the  
State of California  
to cause cancer and  
reproductive harm.**

**WASH HANDS  
AFTER HANDLING!**

**CALIFORNIA PROPOSITION 65**  
**EXHAUST WARNING**

**Diesel Engine exhaust and  
some of its constituents  
are known to the State of  
California to cause cancer,  
birth defects and other  
reproductive harm.**

## **REVISION LOG**

September 15, 2006 - A - Original Issue of Manual

February 22, 2007 - B - Added JLG supplied fork mounted platform information.  
Revised cover and pages 1-9, 2-2 thru 2-4, 3-1, 3-4, 4-1, 4-2 and 6-1.

February 14, 2008 - C - Revised cover and pages 1-1, 1-2, 2-1, 4-1 and 4-2.

## ***Read This First***

---

This manual is a very important tool! Keep it with the machine at all times.

The purpose of this manual is to provide owners, users, operators, lessors, and lessees with the precautions and operating procedures essential for the safe and proper machine operation for its intended purpose.

Due to continuous product improvements, JLG Industries, Inc. reserves the right to make specification changes without prior notification. Contact JLG Industries, Inc. for updated information.

## **Telehandler Operator and Platform Occupant Qualifications**

---

The telehandler operator and platform occupants must read and understand this manual.

The telehandler operator must read and understand the telehandler Operation & Safety Manual and any optional equipment instructions prior to operation.

The operator must also read, understand and comply with all applicable Employer, Industry and Governmental rules, standards and regulations.

## **Modifications**

---

**Any modification to the platform must be approved by the platform manufacturer.**

This product must comply with all safety related bulletins. Contact JLG Industries, Inc. or the local Caterpillar dealer representative for information regarding safety-related bulletins which may have been issued for this product.

JLG Industries, Inc. sends safety related bulletins to the owner of record of this machine. Contact JLG Industries, Inc. to ensure that the current owner records are updated and accurate.

JLG Industries, Inc. must be notified immediately in all instances where JLG products have been involved in an accident involving bodily injury or death of personnel or when damage has occurred to personal property or the JLG product.

**FOR:**

- Accident Reporting and Product Safety Publications
- Current Owner Updates
- Questions Regarding Product Applications and Safety
- Standards and Regulations Compliance Information
- Questions Regarding Product Modifications

**CONTACT:**

Product Safety and Reliability Department  
JLG Industries, Inc.  
1 JLG Drive  
McConnellsburg, PA 17233  
USA

**In USA:**

Toll Free: 877-JLG-SAFE (877-554-7233)

**Outside USA:**

Phone: 717-485-5161 or 717-485-6591

E-mail: ProductSafety@JLG.com

**This Page Intentionally Left Blank**

---

## TABLE OF CONTENTS

### Revision Log

### Read This First

Telehandler Operator and Platform	
Occupant Qualifications .....	b
Modifications .....	b

### Table of Contents

#### Section 1 - General Safety Practices

1.1 Hazard Classification System .....	1-1
Safety Alert System and Safety Signal Words .....	1-1
1.2 General Precautions .....	1-2
1.3 Operation Safety .....	1-3
Electrical Hazards .....	1-3
Tip Over Hazard .....	1-4
Load Falling Hazard .....	1-6
Pinch Points and Crush Hazards .....	1-7
Fall Hazard .....	1-9
Chemical Hazards .....	1-11

#### Section 2 - Pre-Operation and Inspection

2.1 Pre-Operation Check and Inspection .....	2-1
2.2 Safety Decals - JLG Supplied Personnel Work Platform .....	2-2
Fork Mounted .....	2-2
2.3 Walk-Around Inspection .....	2-3
2.4 Warm-Up and Operational Checks .....	2-4
Warm-Up Check .....	2-4
Operational Check .....	2-4

#### Section 3 - Operation

3.1 Platform Operation .....	3-1
Lifting/Lowering Personnel .....	3-1
3.2 Use of the Capacity Chart .....	3-2
Example .....	3-2
3.3 Loading and Securing for Transport .....	3-4

#### Section 4 - Types of Personnel Work Platforms

4.1 Approved Personnel Work Platforms .....	4-1
Fork Mounted Personnel Work Platform .....	4-1
4.2 Unapproved Personnel Work Platforms .....	4-1
4.3 Platform Installation .....	4-2
Fork Mounted Platform .....	4-2

## ***Table of Contents***

---

### **Section 5 - Emergency Procedures**

5.1	Emergency Lowering of Boom .....	5-1
5.2	Incident Notification .....	5-1

### **Section 6 - Specifications**

6.1	Product Specifications - JLG Supplied Personnel	
	Work Platform.....	6-1
	Performance .....	6-1
	Dimensions of Platform .....	6-1

### **Index**

### **Inspection, Maintenance and Repair Log**



---

## **SECTION 1 - GENERAL SAFETY PRACTICES**

---

### **1.1 HAZARD CLASSIFICATION SYSTEM**

#### **Safety Alert System and Safety Signal Words**

---



**DANGER** indicates an imminently hazardous situation which, if not avoided, will result in death or serious injury.



**WARNING** indicates a potentially hazardous situation which, if not avoided, could result in death or serious injury.



**CAUTION** indicates a potentiality hazardous situation which, if not avoided, may result in minor or moderate injury.

## Section 1 - General Safety Practices

---

### 1.2 GENERAL PRECAUTIONS



## WARNING

Before operation, read & understand this manual. Failure to comply with the safety precautions listed in this manual could result in machine damage, property damage, personal injury or death.

- **DO NOT** use the telehandler with platform attached for any purpose other than positioning personnel, their tools and equipment.
- **DO NOT** place boom or platform against any structure to steady the platform or to support the structure.



OAB0050

- Operator must remain in cab and keep platform occupants in direct line of sight.
- Prior to lifting personnel, platform occupants and telehandler operator must establish means of communication.

1.3 OPERATION SAFETY

Electrical Hazards

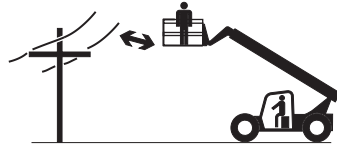
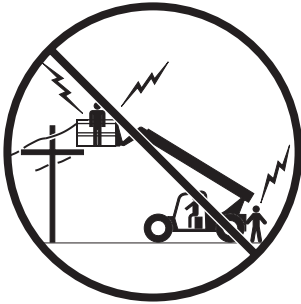

OAB0010

- This machine is not insulated and does not provide protection from contact or proximity to electrical current.

Voltage Range (Phase to Phase)	MINIMUM SAFE APPROACH DISTANCE (MSAD)
0 to 50 KV	10 ft (3 m)
Over 50 KV to 200 KV	15 ft (5 m)
Over 200 KV to 350 KV	20 ft (6 m)
Over 350 KV to 500 KV	25 ft (8 m)
Over 500 KV to 750 KV	35 ft (11 m)
Over 750 KV to 1000 KV	45 ft (14 m)

**Note:** This requirement shall apply except where employer, local or governmental regulations are more stringent.

- Maintain safe distance from electrical lines, apparatus or any energized (exposed or insulated) parts according to the Minimum Safe Approach Distance (MSAD).
- Allow for machine movement and electrical line swaying.
- Maintain a clearance of at least 10 ft (3 m) between any part of the machine and its occupants, their tools and equipment from any electrical line or apparatus carrying up to 50,000 volts. One foot additional clearance is required for every additional 30,000 volts or less.
- The minimum safe approach distance may be reduced if insulating barriers are installed to prevent contact and the barriers are rated for the voltage of the line being guarded. These barriers shall not be part of (or attached to) the machine. The minimum safe approach distance shall be reduced to a distance within the designed working dimensions of the insulating barrier. This determination shall be made by a qualified person in accordance with the employer, local or governmental requirements for work practices near energized equipment.

# Section 1 - General Safety Practices

## Tip Over Hazard

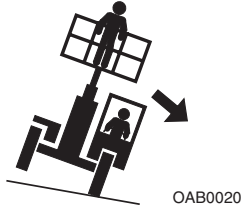

- **DO NOT** exceed rated lift capacity. Distribute loads evenly on platform floor.
- Be sure that the ground conditions are able to support the machine.

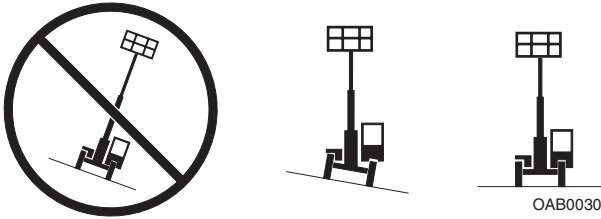

- **DO NOT** raise boom unless frame is level (0 degrees).

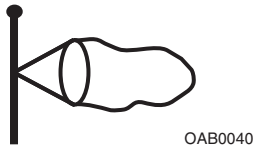

- **DO NOT** lift personnel during thunderstorms, strong winds or other inclement weather.

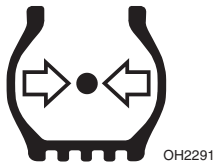

- **MAINTAIN proper tire pressure** at all times. If proper tire pressures are not maintained, this machine could tip over.



OW0170

- **USE ONLY** a JLG approved personnel work platform.



OW0190

- **DO NOT** drive machine from cab when personnel are in platform.

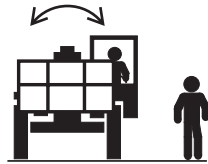

OAB0070

- Never sway the machine when the platform is occupied.

## Section 1 - General Safety Practices

---

### Load Falling Hazard

---



OZ1350

- Never suspend load from platform or supports.
- **DO NOT** carry materials directly on platform railing unless approved by the platform manufacturer.
- Always ensure that power tools are properly stowed and never left hanging by their cord from the platform work area.

**Pinch Points and Crush Hazards**

Stay clear of pinch points and rotating parts on the telehandler.

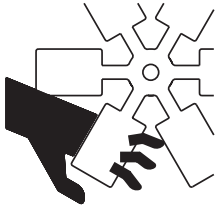

OW0210

- Stay clear of moving parts while engine is running.



OW0220

- Keep clear of tires and platform or other objects.



OW0230

- Keep clear from under boom.



OW0240

- Keep clear of boom holes.

## Section 1 - General Safety Practices

---



OW0250

- Keep arms and hands clear of attachment tilt cylinder.



OAB0170

- During operation, keep all body parts inside platform railing.

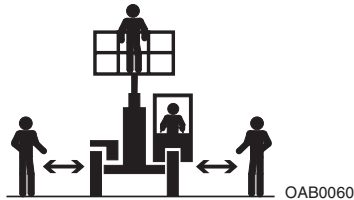

OAB0060

- Keep others away while operating.

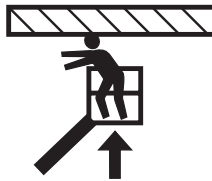

OZ1310

- Approved head gear must be worn by all platform personnel.
- Check work area for clearances overhead, on sides and bottom of platform when lifting or lowering platform. Always look in direction of movement.
- Be sure that operators of other overhead and floor level machines are aware of the machine's presence. Disconnect power to overhead cranes.



### Fall Hazard

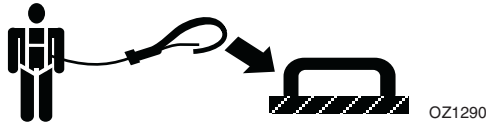

- During operation, occupants in the platform must wear a full body harness with a lanyard attached to an authorized lanyard anchorage point. Attach only one lanyard per lanyard anchorage point.
- **DO NOT** use damaged harnesses, deceleration devices or lanyards.

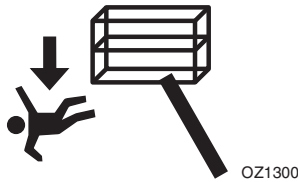

- Before operating the machine, make sure all gates are closed and fastened in their proper position.
- Keep both feet firmly positioned on the platform floor at all times. Never use ladders, boxes, steps, planks or similar items on platform to provide additional reach.
- Use hand rails, if equipped, to maintain balance while platform is in motion.
- Never use the boom assembly to enter or leave the platform.
- Use extreme caution when entering or leaving platform. Be sure that the boom is fully lowered. Face the machine, maintain three point contact with the machine, using two hands and one foot or two feet and one hand during entry and exit.
- Platform-to-structure transfers at elevated positions are discouraged. Where transfer is necessary, enter/exit through the gate only with the platform within 1 ft (0,3 m) of a safe and secure structure. 100% tie-off is also required in this situation utilizing two lanyards. One lanyard must be attached to the platform with the second lanyard attached to the structure. The lanyard connected to the platform must not be disconnected until such time as the transfer to the structure is safe and complete.
- Avoid accumulation of debris on platform floor. Keep mud, oil, grease and other slippery substances from footwear and platform deck.

## Section 1 - General Safety Practices

---



OAB0160

- Never tilt the platform when the platform is occupied.

### Chemical Hazards

---

#### Exhaust Fumes

- **DO NOT** operate machine in an enclosed area without proper ventilation.
- **DO NOT** operate the machine in hazardous environments unless approved for that purpose by JLG and site owner. Sparks from the electrical system and the engine exhaust can cause an explosion.

#### Flammable Fuel



- **DO NOT** fill the fuel tank or service the fuel system near an open flame, sparks or smoking materials. Engine fuel is flammable and can cause a fire and/or explosion.

#### Hydraulic Fluid



- **DO NOT** attempt to repair or tighten any hydraulic hoses or fittings while the engine is running or when the hydraulic system is under pressure.
- Stop engine and relieve trapped pressure. Fluid in the hydraulic system is under enough pressure that it can penetrate the skin.
- **DO NOT** use your hand to check for leaks. Use a piece of cardboard or paper to search for leaks. Wear gloves to protect hands from spraying fluid.

#### Welding

- **DO NOT** use machine as a ground for welding.
- When performing welding or metal cutting operations, precautions must be taken to protect the chassis from direct exposure to weld and metal cutting spatter.

**This Page Intentionally Left Blank**

## SECTION 2 - PRE-OPERATION AND INSPECTION

### 2.1 PRE-OPERATION CHECK AND INSPECTION

**Note:** Complete all required maintenance before operating unit.



## WARNING

**FALL HAZARD.** Use extreme caution when checking items beyond your normal reach. Use an approved ladder. Failure to comply could result in death or serious injury.

A pre-operation check & inspection of the telehandler is to be completed first. Refer to the Operation & Safety Manual supplied with telehandler.

The pre-operation check & inspection, performed at beginning of each work shift or at each change of operator, should include the following:

1. **Cleanliness** - Check all surfaces for foreign objects.
2. **Structure** - Inspect the platform structure for dents, damage, weld or parent metal cracks or other discrepancies.
3. **Safety Decals** - Ensure all safety decals are legible and in place. Clean or replace as required.
4. **Operation & Safety Manual** - Operation & Safety manual located in platform manual holder.
5. **Walk-Around Inspection** - See page 2-3 for details.
6. **Operational Check** - Once the walk-around inspection is complete, perform a warm-up and operational check (see page 2-4) in an area free of overhead and ground level obstructions.



## WARNING

If the telehandler does not operate properly, immediately bring machine to a stop, lower boom and platform to ground and stop engine. Determine cause and correct before continued use.

## Section 2 - Pre-Operation and Inspection

### 2.2 SAFETY DECALS - JLG SUPPLIED PERSONNEL WORK PLATFORM

Ensure all **DANGER, WARNING, CAUTION** and instructional decals and proper capacity charts are legible and in place. Clean and replace as required.

#### Fork Mounted

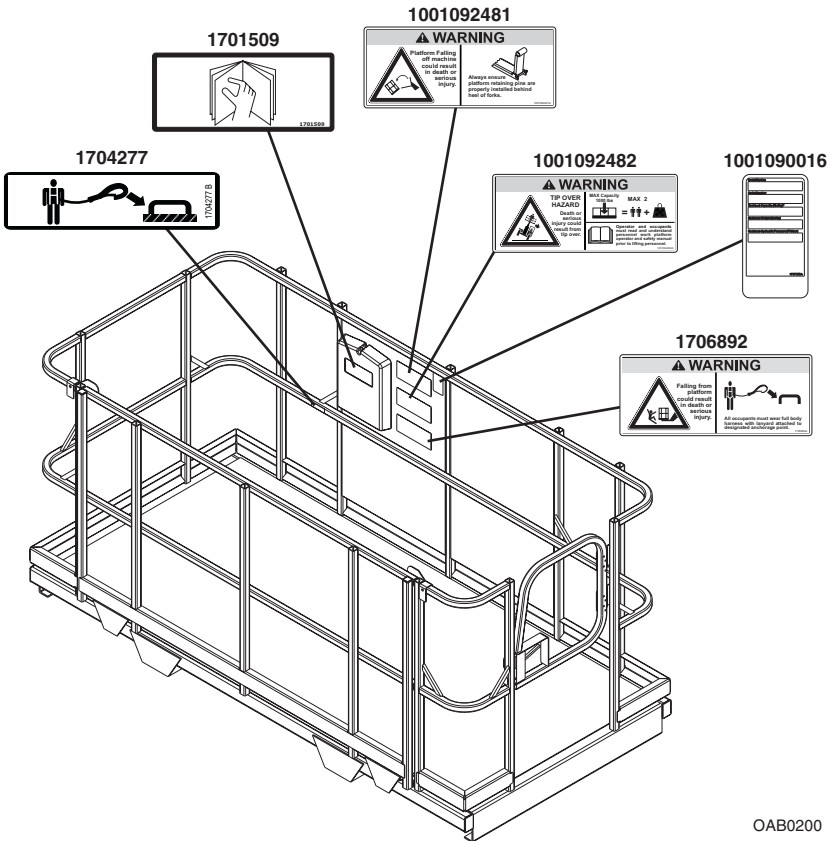

OAB0200

### 2.3 WALK-AROUND INSPECTION

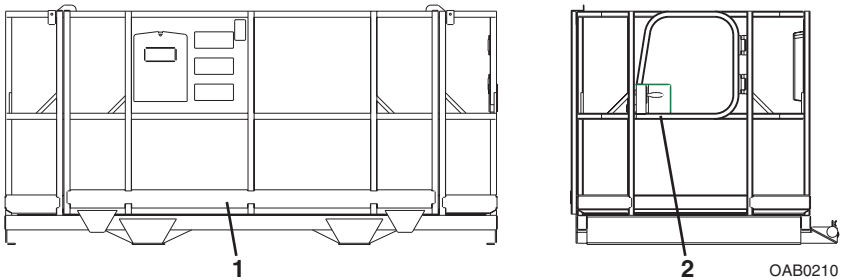

Begin your platform walk-around inspection at item 1, as noted below. Continue checking each item in sequence.

**INSPECTION NOTE:** On all components, make sure there are no loose or missing parts, that they are securely fastened and no visible leaks or excessive wear exists in addition to any other criteria mentioned. Inspect all structural members including attachment and railing for cracks, excessive corrosion and other damage.

#### 1. Platform -

- Properly installed, see “*Platform Installation*” on page 4-2.
- Rail connections properly secure, undamaged and no missing hardware.
- Applicable Operation & Safety Manual located in manual holder.

#### 2. Platform Gate - Clean, undamaged and closes properly.

## ***Section 2 - Pre-Operation and Inspection***

---

### **2.4 WARM-UP AND OPERATIONAL CHECKS**

#### **Warm-Up Check**

---

Warm-up and operational checks of the telehandler are to be completed before entering the platform. Refer to the Operation & Safety Manual supplied with telehandler.

#### **Operational Check**

---

After engine warms, perform an operational check:

1. Horn must be audible from platform with engine running.



## **SECTION 3 - OPERATION**

---

### **3.1 PLATFORM OPERATION**

- JLG recommends the user comply with local, provincial and federal regulations as they pertain to telehandler mounted personnel work platforms.
- Capacities and range limits for the telehandler change depending on the platform in use.
- Separate attachment instructions must be kept in manual holder in cab with this Operation & Safety Manual. An additional copy must be kept with the attachment if it is equipped with a manual holder.
- For fork mounted platforms, the combined weight of the platform, load and personnel shall not exceed one-third of the capacity at the related load center position as indicated on the capacity chart for the attachment on which the personnel work platform is being used.

### **Lifting/Lowering Personnel**

---

- Secure work area.
- Without personnel in the platform, perform a simulated lift with designated signal person on ground as spotter to assure adequate telehandler range and attachment clearances.
- With the park brake applied, lift/lower personnel only at their request and in accordance with the requirements set forth in Section 1 - General Safety Practices and Section 4 - Types of Personnel Work Platforms. The operator shall always sound horn to alert personnel prior to lifting/lowering the platform and operate the joystick slowly and cautiously.

## Section 3 - Operation

---

### 3.2 USE OF THE CAPACITY CHART

#### Example

---

A contractor owns a model xxxxx telehandler with a 48" Carriage. He knows his fork mounted platform may be used with his model/attachment since it follows the requirements set forth in "Approved Personnel Work Platforms" on page 4-1.

The contractor knows the platform's capacity of 1,000 lb (454 kg) can handle the occupant's weight of 450 lb (204 kg) and the load also being lifted of 150 lb (68 kg). The contractor also knows the platform weighs 400 lb (181 kg).

The following are examples with various conditions the contractor may encounter and whether or not the platform may be lifted.

	<b>Load Weight (including platform, load &amp; personnel)</b>	<b>Distance</b>	<b>Height</b>	<b>OK to Lift</b>
1	1000 lb (454 kg)	16 ft (4,9 m)	10 ft (3,0 m)	Yes
2	1000 lb (454 kg)	26 ft (7,9 m)	16 ft (4,9 m)	NO
3	1000 lb (454 kg)	21 ft (6,4 m)	24 ft (7,3 m)	NO
4	1000 lb (454 kg)	8 ft (2,4 m)	30 ft (9,1 m)	Yes

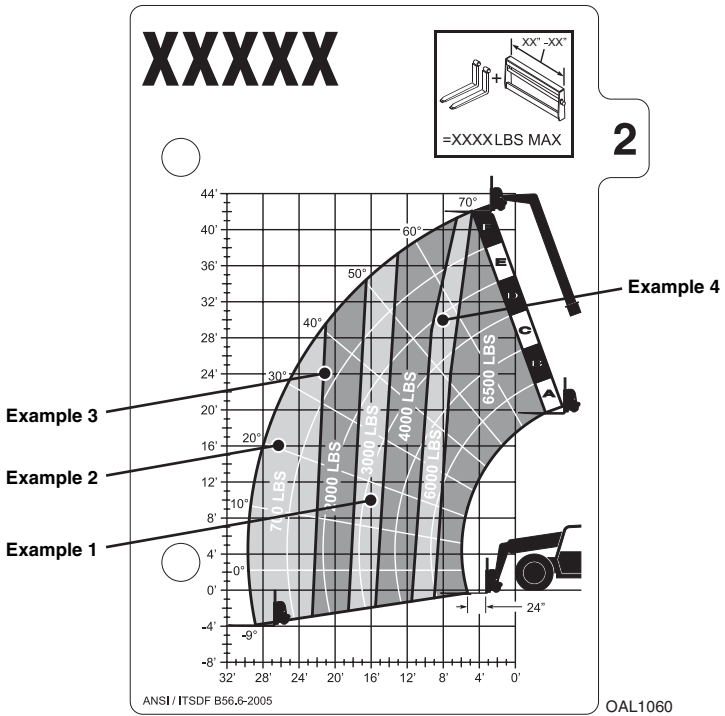

**Note:** This is a sample capacity chart **only!** **DO NOT** use this chart, use the one located in your operator cab.

## Section 3 - Operation

---

### 3.3 LOADING AND SECURING FOR TRANSPORT

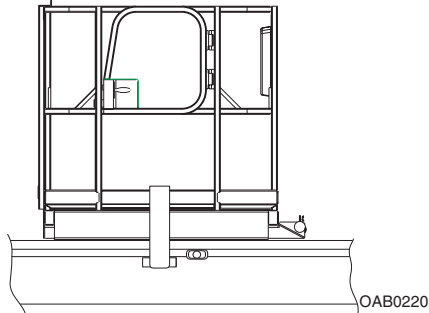

1. If attached to telehandler, refer to the Operation & Safety Manual supplied with telehandler for securing telehandler.
2. Secure platform with strap as shown in figure.

**Note:** *The user assumes all responsibility for choosing the proper method of transportation and tie-down devices, making sure the equipment used is capable of supporting the weight of the attachment/machine being transported and that all manufacturer's instructions and warnings, regulations and safety rules of their employer, the Department of Transportation and/or any other state or federal laws are followed.*

---

## **SECTION 4 - TYPES OF PERSONNEL WORK PLATFORMS**

---

### **4.1 APPROVED PERSONNEL WORK PLATFORMS**

#### **Fork Mounted Personnel Work Platform**

---

Fork mounted personnel work platforms must comply with the design requirements of platforms for elevating personnel as outlined in the current revision of ITSDF B56.6 Safety Standard for Rough Terrain Forklift Trucks.

**Note:** *Compliance to OSHA regulations does not necessarily indicate compliance to ITSDF B56.6.*

If the platform does not meet the design requirements of the B56.6 Standard, do not use the platform.

Contact JLG Product Safety Department at 1-877-554-7233 for additional information.

---

### **4.2 UNAPPROVED PERSONNEL WORK PLATFORMS**

Do not attach any type of personnel work platform that is not manufactured by JLG to the Quick Coupler.

Do not use fork mounted personnel work platforms that do not meet the design requirements. See *"Fork Mounted Personnel Work Platform"* on page 4-1.

Do not use unapproved platforms for the following reasons:

- JLG cannot establish range and capacity limitations for "will fit," homemade, altered, or other non-approved platforms.
- An overextended or overloaded telehandler can tip over with little or no warning and cause serious injury or death to the operator and/or those working nearby.
- JLG cannot assure the ability of a non-approved platform to perform its intended function safely.



## **WARNING**

Use only approved personnel work platforms. Platforms which have not been approved for use with your telehandler could cause machine damage or an accident resulting in death or serious injury.

## ***Section 4 - Types of Personnel Work Platforms***

---

### **4.3 PLATFORM INSTALLATION**

#### **Fork Mounted Platform**

---

JLG fork mounted personnel work platforms must attach to the forks by installing a pin behind the heel of each fork. Prior to use, ensure each pin is installed and secured.

For fork mounted platforms not manufactured by JLG, follow the personnel work platform manufacturer's instructions for installation.

**DO NOT** use fork mounted personnel work platforms with attachments capable of independent motion (i.e. side tilt, swing and mast carriages) without disabling the independent motion feature(s).

---

## **SECTION 5 - EMERGENCY PROCEDURES**

---

### **5.1 EMERGENCY LOWERING OF BOOM**

In the event of total loss of engine power, hydraulic pump failure or if platform or boom becomes jammed or snagged in overhead structures or equipment with an elevated load, the situation must be properly evaluated and dealt with on an individual basis. **Contact the local Caterpillar Dealer or JLG Service Department for specific instructions.**

Secure the telehandler using the following procedures:

1. Rescue platform occupants.
2. Clear the area around telehandler of all personnel.
3. Block all four wheels.
4. Section off a large area under the boom with string or tape to restrict any personnel from entering this area.

---

### **5.2 INCIDENT NOTIFICATION**

JLG Industries, Inc. must be notified immediately of any incident involving a JLG product. Even if no injury or property damage is evident, the factory should be contacted by telephone and provided with all necessary details.

**In USA:**

Toll Free: 877-JLG-SAFE (877-554-7233)

8:00am to 4:45pm EST

**Outside USA:**

Phone: 717-485-5161 or 717-485-6591

**E-mail:**

ProductSafety@JLG.com

Failure to notify the manufacturer of an incident involving a JLG Industries product within 48 hours of such an occurrence may void any warranty consideration on that particular machine.

**Important:**

Following any accident, thoroughly inspect the machine and test all functions from cab controls. Do not lift above 10 ft (3 m) until all damage has been repaired, if required, and all controls are operating correctly.

**This Page Intentionally Left Blank**



---

## **SECTION 6 - SPECIFICATIONS**

---

### **6.1 PRODUCT SPECIFICATIONS - JLG SUPPLIED PERSONNEL WORK PLATFORM**

For telehandler specifications refer to the Operation & Safety Manual supplied with telehandler.

#### **Performance**

---

##### **Fork Mounted**

Maximum Platform Capacity.....	1000 lb (454 kg)
Required Fork Length.....	48 in (1219 mm)

#### **Dimensions of Platform**

---

##### **Fork Mounted**

Platform Overall Height.....	49 in (1255 mm)
Platform Overall Width.....	53.75 in (1365 mm)
Platform Overall Depth .....	101 in (2565 mm)

**This Page Intentionally Left Blank**

---





<b>C</b>		<b>P</b>	
Capacity Chart.....	3-2	Performance .....	6-1
Example .....	3-2	Pinch Points and Crush Hazards .....	1-7
Chemical Hazards .....	1-11	Platform	
		Installation .....	4-2
		Operation.....	3-1
		Pre-Operation Check and	
		Inspection.....	2-1
<b>D</b>		<b>S</b>	
Decals .....	2-2	Safety Decals.....	2-2
Dimensions.....	6-1	Safety Practices .....	1-1
		Safety Signal Words .....	1-1
		Securing for Transport .....	3-4
		Specifications.....	6-1
<b>E</b>		<b>T</b>	
Electrical Hazards .....	1-3	Tip Over Hazard.....	1-4
Emergency Lower of Boom .....	5-1		
Emergency Procedures.....	5-1		
<b>F</b>			
Fall Hazard.....	1-9		
<b>G</b>			
General Precautions.....	1-2		
<b>H</b>			
Hazard Classification System.....	1-1		
<b>I</b>			
Incident Notification .....	5-1		
<b>L</b>			
Lifting/Lowering Personnel.....	3-1		
Load Falling Hazard .....	1-6		
<b>M</b>			
Minimum Safe Approach			
Distance .....	1-3		
<b>O</b>			
Operation.....	3-1		
Operational Check.....	2-4		





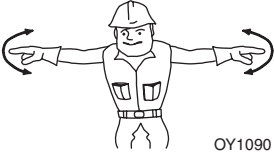
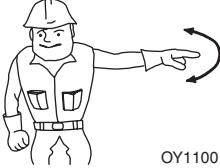

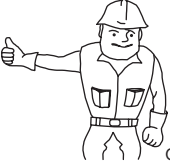
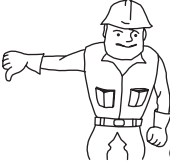
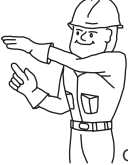
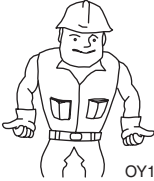
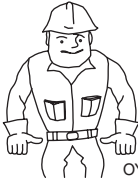
## Hand Signals

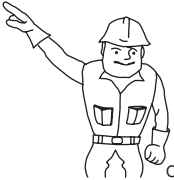
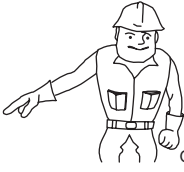
 <p>OY1090</p> <p><b>EMERGENCY STOP</b> - With both arms extended laterally, hands open downward, move arms back and forth.</p>	 <p>OY1100</p> <p><b>STOP</b> - With either arm extended laterally, hand open downward, move arm back and forth.</p>	 <p>OY1110</p> <p><b>STOP ENGINE</b> - Draw thumb or forefinger across throat.</p>
 <p>OY1120</p> <p><b>RAISE BOOM</b> - With either arm extended horizontally, fingers closed, point thumb upward.</p>	 <p>OY1130</p> <p><b>LOWER BOOM</b> - With either arm extended horizontally, fingers closed, point thumb downward.</p>	 <p>OY1140</p> <p><b>MOVE SLOWLY</b> - Place one hand motionless in front of hand giving motion signal. (Raise load slowly shown)</p>
 <p>OY1150</p> <p><b>EXTEND BOOM</b> - With both hands clenched, point thumbs outward.</p>	 <p>OY1160</p> <p><b>RETRACT BOOM</b> - With both hands clenched, point thumbs inward.</p>	 <p>OY1170</p> <p><b>THIS FAR TO GO</b> - With hands raised and open inward, move hands laterally, indicating distance to go.</p>
 <p>OY1180</p> <p><b>TILT FORKS UP</b> - With one arm held at side, extend other arm upward at about 45 degrees.</p>	 <p>OY1190</p> <p><b>TILT FORKS DOWN</b> - With one arm held at side, extend other arm downward at about 45 degrees.</p>	

**Special Signals** - When signals for auxiliary equipment functions or conditions not covered are required, they shall be agreed upon in advance by the operator and signalman.

**CATERPILLAR®**

Manufactured by JLG under license from Caterpillar